

Innovative models of flexible final customers in operation of smart distributed energy systems

Gržanić, Mirna

Doctoral thesis / Disertacija

2022

Degree Grantor / Ustanova koja je dodijelila akademski / stručni stupanj: **University of Zagreb, Faculty of Electrical Engineering and Computing / Sveučilište u Zagrebu, Fakultet elektrotehnike i računarstva**

Permanent link / Trajna poveznica: <https://urn.nsk.hr/urn:nbn:hr:168:834644>

Rights / Prava: [In copyright](#) / [Zaštićeno autorskim pravom.](#)

Download date / Datum preuzimanja: **2024-06-30**



Repository / Repozitorij:

[FER Repository - University of Zagreb Faculty of Electrical Engineering and Computing repository](#)





University of Zagreb

FACULTY OF ELECTRICAL ENGINEERING AND COMPUTING

Mirna Gržanić

**INNOVATIVE MODELS OF FLEXIBLE FINAL
CUSTOMERS IN OPERATION OF SMART
DISTRIBUTED ENERGY SYSTEMS**

DOCTORAL THESIS

Zagreb, 2022



University of Zagreb

FACULTY OF ELECTRICAL ENGINEERING AND COMPUTING

Mirna Gržanić

**INNOVATIVE MODELS OF FLEXIBLE FINAL
CUSTOMERS IN OPERATION OF SMART
DISTRIBUTED ENERGY SYSTEMS**

DOCTORAL THESIS

Supervisor: Associate Professor Tomislav Capuder, PhD

Zagreb, 2022



Sveučilište u Zagrebu
FAKULTET ELEKTROTEHNIKE I RAČUNARSTVA

Mirna Gržanić

**INOVATIVNI MODELI FLEKSIBILNIH KRAJNJIH
KUPACA PRI POGONU NAPREDNIH
ELEKTROENERGETSKIH DISTRIBUCIJSKIH
SUSTAVA**

DOKTORSKI RAD

Mentor: izv. prof. dr. sc. Tomislav Capuder

Zagreb, 2022.

The doctoral thesis was completed at the University of Zagreb Faculty of Electrical Engineering and Computing, Department of Energy and Power Systems, Zagreb, Croatia.

Supervisor: Associate Professor Tomislav Capuder, PhD

Doctoral thesis has: 148 pages

Doctoral thesis number: _____

About the Supervisor

Tomislav Capuder (<https://www.fer.unizg.hr/tomislav.capuder>) was born in 1983 in Zagreb. He received his bachelor's and doctoral degrees from the Faculty of Electrical Engineering and Computing, University of Zagreb. At the same Faculty, he was elected as the assistant professor in 2016, and in 2020 as the associate professor. During his doctoral and postdoctoral studies, he spent several months in training at the University of Manchester in the UK. He won the Silver Josip Lončar Award for the best doctoral dissertation at Faculty of Electrical Engineering and Computing in 2013/2014, the Science Award of the Faculty of Electrical Engineering and Computing for 2015, Vera Johanides Award of the Croatian Academy of Engineering and many others.

His area of interest covers integrated energy infrastructure, multi-energy systems, electric power systems planning and operation, energy markets, modeling and optimization of electric power system, with emphasis on advanced distribution networks.

He is the author of a chapter in a book, 3 editorial books, 31 papers in category A journals (of which 19 papers were published in Q1 journals) and more than 50 papers in conference proceedings with international peer-review, and over 100 technical studies. In 2016, he received the award for the best reviewer of the IEEE Transactions on Smart Grid and the award for the best reviewer of the International Journal on Electrical Power and Energy Systems (both journals are indexed in the Current Content database), while in 2019 he received the award for the best reviewer of the IEEE Transactions on Smart Grid and IEEE Transactions on Power Systems.

He is the leader of several international and national research and development projects.

He was the secretary of the international conferences Smart Grid World Forum 2010 and European Energy Market 2011, as well as the chairman of the board of international conference IEEE EUROCON 2013. He was also one of the presidents of the program committee of the international conference IEEE ENERGYCON 2014, and one of the members of the program committee of IEEE ENERGYCON 2016 and IEEE Energycon 2018. He was the president of the international conference Medpower 2018.

He is a member of scientific and technical associations HRO CIGRE, SDEWES, IEEE, and in Croatia IEEE section currently serves as President of the Department of Energy.

<https://orcid.org/0000-0002-7657-150X>

<https://scholar.google.hr/citations?hl=hr&user=I2dX-pkAAAAJ>

<https://www.researchgate.net/profile/Tomislav-Capuder>

<https://www.scopus.com/authid/detail.uri?authorId=35222878400>

<https://publons.com/researcher/1390786/tomislav-capuder/>

O mentoru

Tomislav Capuder (<https://www.fer.unizg.hr/tomislav.capuder>) rođen 1983. godine u Zagrebu. Diplomirao je i doktorirao na Fakultetu elektrotehnike i računarstva Sveučilišta u Zagrebu. Na istom Fakultetu izabran je u znanstveno-nastavno zvanje docent 2016. godine, a 2020. godine u znanstveno-nastavno zvanje izvanredni profesor. Tijekom doktorskog i poslijedoktorskog studija proveo je više mjeseci na usavršavanju na Sveučilištu u Manchesteru u Velikoj Britaniji. Dobitnik je nagrade Srebrni Josip Lončar za najbolju doktorsku disertaciju Fakulteta elektrotehnike i računarstva u 2013/2014 godini, Nagrade za znanost Fakulteta elektrotehnike i računarstva za 2015 godinu, Nagrade Vera Johanides Hrvatske akademije tehničkih znanosti te mnogih drugih.

Istraživački interesi obuhvaćaju integrirane energetske infrastrukture, višegeneracijske sustave, planiranje i vođenje elektroenergetskih sustava, tržišta energije, modeliranje i optimiranje elektroenergetskog sustava, s naglaskom na napredne distribucijske mreže.

Autor je poglavlja u knjizi, 3 uredničke knjige, 31 rada u časopisima kategorije A (od toga 19 radova je objavljeno u Q1 časopisima) i više od 50 radova u zbornicima skupova s međunarodnom recenzijom, te preko 100 stručnih studija i elaborata. Član je uredničkih odbora nekoliko međunarodnih znanstveno stručnih časopisa (od čega je International Transactions on Electrical Energy Systems indeksira u Current Content bazi). U 2016. godini dobio je nagradu za najboljeg recenzenta časopisa IEEE Transactions on Smart Grid i nagradu za najboljeg recenzenta časopisa International Journal on Electrical Power and Energy Systems (oba časopisa indeksirana su u bazi Current Content), dok je u 2019. godini dobio je nagradu za najboljeg recenzenta časopisa IEEE Transactions on Smart Grid i IEEE Transactions on Power Systems.

Voditelj je više međunarodnih i nacionalni znanstveno-istraživačkih i razvojnih projekata.

Bio je tajnik međunarodnih konferencija Smart Grid World Forum 2010 i European Energy Market 2011 te predsjednik Organizacijskog odbora međunarodne konferencije IEEE EUROCON 2013. Također bio jedan od predsjednika programskog odbora međunarodne konferencije IEEE ENERGYCON 2014, te je jedan od članova programskog odbora IEEE ENERGYCON 2016 i IEEE Energycon 2018. Bio je predsjednik međunarodne konferencije Medpower 2018.

Član je znanstvenih i stručnih udruga HRO CIGRE, SDEWES, IEEE, a u Hrvatskoj sekciji IEEE trenutno obnaša dužnost Predsjednika Odjela za energetiku.

<https://orcid.org/0000-0002-7657-150X>

<https://scholar.google.hr/citations?hl=hr&user=I2dX-pkAAAAJ>

<https://www.researchgate.net/profile/Tomislav-Capuder>

<https://www.scopus.com/authid/detail.uri?authorId=35222878400>

<https://publons.com/researcher/1390786/tomislav-capuder/>

Abstract

The increasing share of renewable energy sources (RES) is one of the main goals in the transition towards a carbon-neutral power system. Due to their intermittent nature, RES require an additional level of flexibility to ensure stable and secure power system operation. In the past, the flexibility used to be provided from conventional power plants, such as coal power plants which are less flexible and open-cycle gas turbine (OCGT) and natural gas-fired internal combustion engine (ICE) power plants with a high level of flexibility characterized with short minimum uptime and minimum downtime, short start-up time and low start-up cost.

However, the enlarged need for flexibility in green energy transitions opens the doors for providing system services from the end-user's side. The role of final customers has been under significant changes. From completely passive entities, final customers are becoming active network participants involved in the real-time (RT) power system operation. With the recent price decrease of low carbon technology, more final customers tend to invest in photovoltaic (PV) systems, household battery energy storage (BES), electric vehicles (EV), and household energy management systems (HEMS). To fully exploit their potential, European directives highlight the importance of providing transparent and easy-to-understand pricing mechanisms together with pricing comparison tools in order to ensure fair and the most economic solutions to all final customers. As some final customers, such as households, are too small to independently trade their flexibility on the market, a new market entity called aggregator gathers their flexibility potential and trades with their services on the market. Final customer's flexible behaviour can be remunerated through direct incentives, electricity bill reduction or even a discount for investing in low-carbon technology and fixed annual direct payments for flexible management of different household appliances.

The thesis investigates the impact of diverse pricing mechanisms on the behaviour of final customers, their consumption profile, and electricity bill in different European countries considering not only energy prices, but also transmission and distribution network charges, tax, VAT, and the pricing policy related to RES installed at final customer's side. Flat prices, two-tariff pricing, and RT dynamic pricing for prosumers are compared resulting in more flexible behaviour and electricity bill reduction under dynamic prices. In general, the current pricing structure encourages final customers with installed RES to shift their flexible consumption in the periods of high production, instead of selling excess to the supplier.

Furthermore, the thesis deals with different forms of aggregation resulting not only in financial benefits to all entities involved but also reducing the negative impact of the intermittent nature of RES. The first type of aggregation investigated in the thesis is a formation of an innovative balancing group (BG) composed of the aggregator of flexible prosumers and a wind power plant (WPP) participating in the day-ahead (DA) energy market and balancing market.

The focus is put on joint market participation which reduces prosumers' electricity cost and increases WPP profit due to decreased balancing cost arising from flexible behaviour of final prosumers which serve as a buffer between balancing market and the intermittent and variable WPP's production.

The second type of aggregation in the thesis is focused on an energy community. The energy community will participate in the power system transition by allowing the participation of citizens in the clean energy transition in diverse legal forms, such as associations, cooperatives, partnerships, non-profit organizations, and small/medium enterprises. Community members investigated in the thesis are equipped with PV, flexible electric heating, flexible household appliances, and have an opportunity of smart EV charging. The community is operated by the community manager (CM) who is in control of flexible household devices through HEMS. The CM tackles the issue of the stochastic nature of PV and households' consumption by providing flexibility incentives to community members in order to reduce the deviation from preannounced DA schedule. The energy community participates on the market as a single entity and the cost of community members is calculated ex-post, after energy delivery which makes the optimization algorithm simple to solve. Prices for the internal energy exchange between community members are calculated based on three pricing mechanisms: Bill Sharing Method Net (BSMN), Mid-Market Rate Net (MMRN), and Supply Demand Ratio Net (SDRN) taking into account the net load of each community member, DA energy prices and flexibility incentives. Participation in the energy community together with the price calculation developed in the thesis which is conducted in a two-stage process guarantee lower electricity cost to each community member compared to their individual contract with the supplier.

Keywords: Aggregator, Energy Community, Demand Response, Dynamic pricing, Flexibility Incentives

Inovativni modeli fleksibilnih krajnjih kupaca pri pogonu naprednih elektroenergetskih distribucijskih sustava

Ambiciozni ciljevi Europske unije teže smanjenju stakleničkih plinova za 55% do 2030. godine u usporedbi s emisijama iz devedestih godina prošlog stoljeća kako bi se smanjio globalni porast temperature na 1.5°C uz povećanje energetske učinkovitosti. Kako bi se to ostvarilo, potrebno je povećanje udjela obnovljivih izvora energije (OIE) što je jedan od glavnih ciljeva tranzicije prema niskougljičnom elektroenergetskom sustavu. Upravljanje elektroenergetskim sustavom s visokim udjelom OIE je složenije i zahtjevnije od upravljanja tradicionalnim elektroenergetskim sustavom. Zbog svoje isprekidane prirode, OIE zahtijevaju dodatnu razinu fleksibilnosti kako bi se osigurao stabilan i siguran rad elektroenergetskog sustava. U prošlosti su fleksibilnost pružale konvencionalne elektrane, kao što su manje fleksibilne elektrane na ugljen te plinske turbine otvorenog ciklusa (OCGT) i elektrane s unutarnjim izgaranjem na prirodni plin (ICE) s visokom razinom fleksibilnosti koju karakterizira kratko minimalno vrijeme prije ponovnog gašenja i paljenja, kratko vrijeme pokretanja i niski troškovi pokretanja.

Unatoč svim izazovima koji se javljaju u tranziciji prema niskougljičnom elektroenergetskom sustavu, operator sustava dužan je na siguran i efikasan način planirati i upravljati sustavom. Povećana potreba za fleksibilnošću u zelenoj energetskej tranziciji otvara vrata za pružanje pomoćnih usluga od strane krajnjih korisnika čija se uloga značajno mijenja. Od pasivnih entiteta, krajnji kupci postaju aktivni mrežni sudionici uključeni u rad elektroenergetskog sustava. S nedavnim smanjenjem cijena niskougljičnih tehnologija, sve više krajnjih kupaca ulaže u fotonaponske (PV) sustave, baterijske spremnike, električna vozila (EV) i sustave za upravljanje energijom u kućanstvu (HEMS). Kako bi krajnji kupci u potpunosti iskoristili svoj potencijal, europske direktive ističu njihovu važnost te ih stavljaju u centar niskougljične tranzicije. Posebno je istaknuto da se svim krajnjim kupcima moraju omogućiti poštena i ekonomična rješenja pružajući im na transparentan i lako razumljiv način različite mogućnosti odabira cijena električne energije, zajedno s alatima za usporedbu cijena, koji će omogućiti brzu i prikladnu promjenu opskrbljivača. Krajnji kupci trebaju imati točne informacije o svojem obračunu koje se temelje na stvarnoj potrošnji električne energije što im omogućuje bolju kontrolu vlastite potrošnje i troška električne energije.

Zbog premalih snaga krajnjih kupaca, novi tržišni subjekt agregator okuplja krajnje korisnike i njihovu fleksibilnost te sudjeluje na različitim tržištima. Kako bi se agregatorima omogućilo posrednost između tržišta i krajnjih kupaca te kako bi se osiguralo da krajnji kupac ostvaruje odgovarajuću korist od njihove aktivnosti, svaki krajnji kupac treba biti obaviješten o izabranom modelu koji sadržava transparentna i poštena pravila. Kako bi se na pošten način potaknulo upravljanje potrošnjom, usluge koje nude agregatori trebaju biti definirane na svim tržištima, uključujući tržišta električnom energijom, tržišta pomoćnih usluga i tržišta kapaciteta.

Ugovor o agregiranju svaki krajnji kupac može sklopiti neovisno o svom opskrbljivaču. Fleksibilno ponašanje krajnjeg kupca može se nagraditi izravnim poticajima, smanjenjem računa za električnu energiju ili čak smanjenom investicijskom cijenu za brojne niskougljične tehnologije i fiksnim godišnjim izravnim plaćanjima za fleksibilno upravljanje kućanskim uređajima.

Postoje dvije grupe odziva potrošnje na temelju kojih krajnji korisnici mogu pružiti fleksibilnost elektroenergetskom sustavu. Prva grupa obuhvaća cjenovno potaknute programe odziva potrošnje, dok druga grupa obuhvaća programe stimulirane različitim poticajima. U cjenovno potaknute programe spadaju različite opcije promijenjivih cijena električne energije:

- Višetarifni sustavi - dvije ili više unaprijed određenih tarifa koje se izmjenjuju tijekom dana u unaprijed određenim fiksnim intervalima za vrijeme trajanja ugovora. Svaka tarifa pokriva dulji vremenski interval tijekom dana (npr. niže cijene tijekom noći i više cijene tijekom dana).
- Visoke cijene tijekom vršnog opterećenja - značajni porast cijena električne energije za vrijeme vršnog opterećenja tijekom nekoliko kritičnih dana u godini koji su unaprijed najavljeni.
- Popusti tijekom vršnog opterećenja - popusti krajnjim korisnicima koji pristanu smanjiti svoju potrošnju za vrijeme vršnog opterećenja.
- Postupno povećanje tarife ovisno o ukupnoj potrošnji - količina potrošene električne energije podijeljena je u više kategorija. Svaka kategorija odgovara određenoj cijeni koja raste s povećanjem potrošnje i prelaskom u iduću kategoriju. Ukupna mjesečna cijena jednaka je sumi umnoška cijene u pojedinoj kategoriji i količini potrošene električne energije u toj kategoriji.
- Dinamičke cijene na satnoj razini - cijene određene dan-unaprijed koje variraju na satnoj razini te prate stanje na tržištu električnom energijom.

Programi stimulirani poticajima mogu se podijeliti u četiri kategorije:

- Direktno upravljanje potrošnjom - najčešće direktno upravljanje klimatizacijskim uređajima, grijanjem i bojlerima od strane operatora sustava. Operator sustava unaprijed odredi maksimalni broj aktivacija i vrijeme trajanja usluge. S obzirom na to da krajnji korisnici ugovorom pristanu na izravno upravljanje uređajima od strane operatora sustava, najčešće se ne šalje nikakva obavijest krajnjim potrošačima ili se pošalje neposredno prije aktivacije usluge. Krajnji potrošači dobivaju fiksni iznos naknade određene ugovorom te dodatnu naknadu ukoliko je operator sustava uslugu aktivirao.
- Programi smanjenja potrošnje - programi u kojima se unaprijed najavi krajnjim korisnicima kada je potrebno smanjiti potrošnju (nekoliko minuta, sati ili čak dan unaprijed). Krajnji korisnik smanjuje svoju potrošnju automatiziranim načinom ili ručno, ovisno o uvjetima dogovorenim u ugovoru.
- Programi prekida potrošnje - krajnji korisnici u ovom programu pristaju na djelomični ili

potpuni prekid potrošnje za vrijeme vrlo visokih cijena električne energije ili u trenucima kada je ugrožena sigurnost elektroenergetskog sustava.

- Tržišno orijentirani programi - obuhvaćaju agregiranje krajnjih korisnika od strane agregatora koji sudjeluje na tržištu pomoćnih usluga.

Doktorska disertacija istražuje utjecaj različitih cijenovnih mehanizama na krajnje kupce u europskim zemljama, uzimajući u obzir ne samo cijene električne energije, već i naknade za prijenosnu i distribucijsku mrežu, različite vrste poreza i cjenovnu politiku vezanu uz OIE instalirane na strani krajnjeg kupca.

Iako krajnji kupci imaju mogućnost odabira dinamičkih cijena koje reflektiraju tržišne cijene samo u osam zemalja u Europi, energetske politike ističu da države članice moraju omogućiti sklapanje ugovora s dinamičkim cijenama za krajnje kupaca s ugrađenim pametnim brojlilima od strane barem jednog opskrbljivača. U disertaciji se uspoređuju troškovi krajnjih korisnika koji imaju mogućnost odabira jednotarifne cijene, dvotarifne cijene i dinamičke cijene pokazujući fleksibilnije ponašanje i smanjenje računa za električnu energiju kod dinamičkih cijena. Trenutna struktura cijena (niže prodajne cijene od kupovnih cijena) potiče krajnje kupce da preusmjere svoju fleksibilnu potrošnju u razdoblje s visokom proizvodnjom iz OIE, umjesto da višak prodaju opskrbljivaču.

Nadalje, doktorska disertacija se bavi različitim oblicima agregacije koji rezultiraju ekonomskim povlasticama za sve uključene subjekte, ali i smanjenjem negativnog utjecaja varijabilne proizvodnje iz OIE. Prva vrsta agregiranja razmatrana u disertaciji je formiranje inovativnog oblika bilančne grupe koja se sastoji od agregatora krajnjih kupaca s vlastitom proizvodnjom i vjetroelektrane (VE) koji sudjeluju na tržištu dan unaprijed i na tržištu uravnoteženja. Problem je definiran kao stohastički dvorazinski model mješovitog cjelobrojnog programiranja baziran na Stackelbergovoj igri. U gornjoj razini promatra se maksimizacija profita agregatora i VE koji predstavljaju vođe u Stackelbergovoj igri određujući cijene aktivnim kupcima s vlastitom proizvodnjom. Donja razina minimizira trošak električne energije aktivnih kupaca s vlastitom proizvodnjom koji na temelju cjenovnih signala iz gornje razine optimiziraju svoju potrošnju te sudjeluju u razmjeni energije s VE nastojeći smanjiti njena odstupanja od dan-unaprijed ugovorenog profila proizvodnje upravljajući vlastitim baterijskim spremnicima i fleksibilnim grijanjem. Promatrane su tri različite mogućnosti određivanja cijena krajnjim kupcima: unaprijed dugoročno definirane dvotarifne cijene, dinamičke promijenjive cijene koje određuje agregator optimizacijom te tržišne cijene uvećane za fiksnu naknadu od strane agregatora. Fokus je stavljen na usporedbu individualnog nastupa agregatora i VE na tržištu te njihovo zajedničko sudjelovanje kojim se smanjuju troškovi električne energije krajnjih kupaca i povećava profit VE zbog smanjenih troškova uravnoteženja koji proizlaze iz fleksibilnog ponašanja krajnjih kupaca koji služe kao tzv. amortizer između tržišta uravnoteženja i isprekidane proizvodnje iz VE. Rezultati su pokazali da dinamičke promjenjive cijene koje određuje agregator optimizacijom potiču kra-

jnje korisnike na fleksibilno ponašanje kada je potrebno pomoći VE u smanjenju odstupanja. Tako određene cijene pogoduju i agregatoru i krajnjim korisnicima jer optimizacija uzima u obzir i cijene električne energije na tržištu te potiče krajnje korisnike na smanjenje potrošnje za vrijeme visokih cijena čime se direktno smanjuje trošak krajnjih korisnika i povećava profit agregatora. Model je dodatno istražio kako povećanje broja članova bilančne grupe koji imaju baterijski spremnik utječe na tijek novca unutar grupe. Povećanje broja krajnjih korisnika s baterijskim spremnikom u bilančnoj grupi ne umanjuje značajno trošak bilančne grupe.

Međutim, kod tržišnih cijena uvećanih za fiksnu naknadu od strane agregatora povećanjem broja baterija u bilančnoj grupi značajno se smanjuje trošak krajnjih korisnika. Upravo zato što su te cijene više orijentirane na krajnjeg korisnika i smanjenje njegovog troška, ne potiču pružanje usluge fleksibilnosti VE.

Druga vrsta agregacije usmjerena je na energetska zajednicu. Energetska zajednica sudjelovat će u rekonstrukciji elektroenergetskog sustava sudjelovanjem građana u zelenoj tranziciji u različitim pravnim oblicima, poput udruga, zadruga, partnerstava, neprofitnih organizacija i malih / srednjih poduzeća. Metode izračuna troškova u energetska zajednici svrstane su u tri kategorije: modeli bazirani na teoriji igara, modeli bazirani na formiranju koalicije i modeli u kojima se cijene računaju ex-post izvan optimizacijskog algoritma. Modeli bazirani na teoriji igara su računski zahtjevni te njihova složenost raste eksponencijalno s brojem članova. Modeli bazirani na formiranju koalicije ponekad su ograničeni s ukupnim brojem članova u koaliciji što spriječava formiranje velike koalicije koja omogućuje ostvarivanje najvećih ušteda što potencijalno dovodi do financijskog nezadovoljstva članova zajednice. Modeli u kojima se cijene računaju ex-post jednostavni su za implementaciju i garantiraju konvergenciju, međutim neki od njih ne rezultiraju nižim troškovima članovima zajednice. Model predstavljen u disertaciji riješio je taj problem uvođenjem dvostupanjskog računanja troška električne energije.

Članovi zajednice u disertaciji opremljeni su solarnim panelima, fleksibilnim električnim grijanjem, baterijskim spremnikom, fleksibilnim kućanskim aparatima i imaju mogućnost pametnog punjenja EV. Zajednicom upravlja upravitelj zajednice (UZ) koji kontrolira fleksibilne uređaje u kućanstvu putem HEMS-a. UZ uzima u obzir stohastičku prirodu solarnih panela i potrošnje kućanstava pružajući poticaje za fleksibilnost članovima zajednice kako bi se smanjilo odstupanje od dan-unaprijed najavljenog rasporeda. Uštede ostavrene pametnim upravljanjem uređajima u kućanstvu dijele se među članovima energetske zajednice. UZ je entitet drugačiji od tradicionalnog opskrbljivača jer mu cilj nije ostvarivanje profita. To je zapravo platforma koja članovima zajednice pruža različite opcije pri monetiziranju fleksibilnosti, ali ih izlaže i riziku promjenjivosti cijena koji je inače tradicionalno snosio opskrbljivač. Kod tradicionalnog ugovora s opskrbljivačem opisanog u disertaciji prema danskom modelu maloprodajnog tržišta (Danska je odabrana u disertaciji zbog javno dostupnih podataka o svim komponentama računa električne energije, međutim model se može primijeniti na bilo kojem maloprodajnom tržištu koje

nudi mogućnost odabira dinamičkih cijena) krajnji korisnik snosi trošak električne energije, trošak uravnoteženja po svakom kupljenom ili prodanom kWh električne energije te mrežne troškove za svaki kupljeni kWh električne energije.

Energetska zajednica sudjeluje na tržištu kao jedna cjelina, a troškovi članova zajednice računaju se dan nakon isporuke energije, izvan optimizacijskog algoritma što ga čini jednostavnim za rješavanje. Energetska zajednica kao cjelina snosi trošak električne energije i mrežne troškove za svaki kupljeni kWh električne energije. Za razliku od individualnog ugovora s opskrbljivačem gdje se plaća određeni trošak uravnoteženja za svaki kupljeni i prodani kWh električne energije, energetska zajednica snosi troškove uravnoteženja kada odstupa od dan-unaprijed predviđenog rasporeda. Smanjenje troškova uravnoteženja ostvareno je fleksibilnim poticajima.

Cijene za unutarnju razmjenu energije između članova zajednice računaju se na temelju tri mehanizma određivanja cijena: neto metoda dijeljenja računa (eng. Bill Sharing Method Net), neto srednje-tržišna stopa (eng. Mid-Market Rate Net) i neto omjer opskrbe i potražnje (eng. Supply Demand Ratio Net), uzimajući u obzir neto potrošnju svakog člana zajednice (razliku između ukupne potrošnje i proizvodnje na satnoj razini), dan-unaprijed cijene energije i poticaje za fleksibilnost. Cijene se računaju u dvostupanjskom postupku koji jamči niže troškove električne energije svakom članu zajednice u odnosu na njihov pojedinačni ugovor s opskrbljivačem. U prvom stupnju računaju se cijene za kupnju i prodaju električne energije unutar energetske zajednice za svaki sat i za svaku metodu zasebno. Nakon toga slijedi izračun ukupnog dnevnog ili mjesečnog troška svakog člana zajednice uzimajući u obzir da li je član zajednice u pojedinom satu kupac ili prodavatelj električne energije. U drugom stupnju uspoređuje se trošak svakog člana zajednice s troškom pri individualnim ugovorom s opskrbljivačem. Ukoliko bilo koji član energetske zajednice ima viši trošak električne energije na kraju obračunskog razdoblja (dnevnog ili mjesečnog) radi se preraspodjela troškova. Preraspodjela troškova omogućuje da svaki član zajednice ima manji trošak unutar zajednice u usporedbi s individualnim ugovorom s opskrbljivačem. Izračuna se minimalna vrijednost potrebne preraspodjele troškova na temelju razlike u pojedinačnom trošku i trošku svakog korisnika energetske zajednice te se matematičkim modelom definiranom u disertaciji dolazi do novih troškova koji garantiraju niži trošak električne energije unutar zajednice za sve članove zajednice.

Od tri navedene metode izračuna cijena električne energije unutar zajednice, neto srednje-tržišna stopa i neto omjer opskrbe i potražnje garantiraju niže cijene električne energije svakom članu zajednice. Zbog specifičnosti izračuna cijena u neto metodi dijeljenja računa, članovi zajednice s vlastitom proizvodnjom snose viši trošak električne energije jer se višak proizvodnje unutar zajednice dijeli besplatno, čime profitiraju isključivo krajnji kupci bez vlastite proizvodnje.

Ključne riječi: Agregator, Energetska zajednica, Odziv potrošnje, Dinamičke cijene, Poticaji za fleksibilnost

Contents

- 1. Introduction 1**
 - 1.1. Background and Motivation1
 - 1.2. Objective of the Thesis2
 - 1.3. Structure of the Thesis3

- 2. Final customers in the center of energy transition 5**
 - 2.1. Introduction in electricity markets5
 - 2.2. Transition towards the prosumer-oriented power system8
 - 2.3. Demand response programs9
 - 2.4. Aggregation of final customers11
 - 2.4.1. Microgrids12
 - 2.4.2. Energy communities13
 - 2.4.3. Virtual power plants or aggregators16
 - 2.5. Connection to the Contributions19

- 3. Mathematical modelling and optimization problems 21**
 - 3.1. Types of optimization problems21
 - 3.1.1. Convex optimization models21
 - 3.1.2. Non-convex optimization models22
 - 3.2. Solving optimization models22
 - 3.2.1. Exact methods23
 - 3.2.2. Heuristics methods25
 - 3.3. Bi-level optimization27
 - 3.4. Uncertainty modelling29
 - 3.5. Market and final customer modelling in the thesis30

- 4. Main Scientific Contributions 32**
 - 4.1. Critical evaluation of the final customer role in low-carbon energy transition . .32
 - 4.2. Innovative pricing method for calculation of internal electricity prices in the energy community33

4.3. Bi-level model of Energy Sharing in Aggregator-Wind Power Plant-Flexible Prosumers Balancing group34
5. List of Publications	35
5.1. Journal Papers35
5.2. Conference Papers35
6. Author’s Contribution to the Publications	37
7. Conclusions and Future Work	40
7.1. The Main Conclusions of the Thesis40
7.2. Future Work41
Bibliography	42
Abbreviation	54
Publications	56
Biography	147
Životopis	148

Chapter 1

Introduction

The main goal of the green energy transition is to reduce the harmful effects of greenhouse gas emissions on the climate. The European Union (EU) member states agreed on an ambitious goal of reducing CO₂ emissions, improving energy efficiency, and increasing share of Renewable Energy Sources (RES) which will make Europe the leader in carbon-neutrality by 2050. To accomplish these goals, significant changes in power system planning and operation are required. Due to their variable nature, broad integration of RES requires an increased level of flexibility.

In order to ensure the required level of flexibility in the power system, the research conducted in this thesis puts the focus on providing flexibility from the final customer's side as one of the actors in the clean energy transition. The main goal of the research is to investigate diverse pricing signals to final customers which reduce their electricity cost and at the same time stimulate their flexible behaviour according to the power system's needs.

1.1 Background and Motivation

The process of power system decarbonization implies a pathway from a fossil-based to a carbon-neutral energy sector. As the main goal is to mitigate global warming, the main focus has been put on the reduction of greenhouse gas emissions and their harmful effects on the climate. Decarbonization requires RES integration on a world-wide scale together with the improvement of energy efficiency. The key factor in the energy transition together with the decarbonization is large-scale electrification, from industry sector, buildings to transport. Predictions say that electricity consumption in total energy consumption of electricity will increase from 20% to 40% by 2050 implying a triple increase of RES compared to research from 2018 [1]. The traditional power system was not designed to carry out the variable and intermittent nature of RES. In the past, conventional power plants were used as the main sources of flexibility, i.e. to balance alternating demand and provide frequency and non-frequency ancillary services (AS).

The transformation of the power systems based mainly on RES production increases the level of uncertainty and operational complexity. A high share of RES poses a reliability risk connected to the lack of system inertia aggravating the balance between demand and supply. To remove these barriers, it is crucial to achieve a high level of flexibility, on both the production and demand sides. It is necessary to change the policies which will enable the provision of flexibility services from different types of entities (battery energy storage (BES) units, aggregators of active customers through demand response (DR) programs, etc.) and establish adequate and fair remuneration. Unlike network reinforcement decisions which require expensive investments in new assets, unlocking flexibility potential from the final customer's side requires installation of Household Energy Management System (HEMS) and increased awareness of benefits from flexible consumption achieved through diverse options of financial incentives.

Financial mechanisms for flexible behaviour remuneration can be provided in different forms, such as implicit or explicit demand response programs. Moreover, aggregation in energy communities, microgrids, or virtual power plants (VPP) will bring additional savings for final customers. This will encourage load shifting of flexible appliances according to the power system's needs, stimulate local energy exchange which will reduce the impact on the external grid and at the same time reduce the electricity bill of final customers. It is discernible that final customers will play a vital role in the transition towards the carbon-neutral power system.

1.2 Objective of the Thesis

The transition towards decarbonized power system requires complete changes in both planning and operation stages. To reduce the harmful effects of greenhouse gas emissions, high penetration of RES requires additional flexibility. In line with low-carbon policies, this flexibility cannot be provided from fossil-fuel-driven power plants, which implies that alternative sources of flexibility are required, such as flexible hydropower plants, BES units, and demand-side flexibility. The demand side flexibility has drawn the broad attention of the research community in recent years. When it comes to balancing fast changes and forecast errors in load and generation, industrial DR, smart charging of EV, and aggregator of flexible prosumers can react and provide the required flexibility from a second to an hour range. Balancing variability in net load and seasonal energy availability is more prone to a longer period, from an hour range to several months, and can be provided from electric water heaters and district heating [1].

However, the majority of final customers are still passive entities and it is important to raise their contribution in the clean energy framework. With the broad installation of smart meters, adequate education and decreasing prices of low-carbon technology (photovoltaic (PV) modules [2], BES [3]), the changes in their behaviour can have a significant effect on increasing power system flexibility. To achieve this, regulations declare that suppliers have to offer dynamic price

signals which reflect the real market situation. On the other hand, final customers are allowed to offer their flexibility potential providing AS through an aggregator without the consent of their supplier. Aggregators and their services should be treated equally with other market participants. In line with this, aggregators need to provide pricing mechanisms to stimulate and adequately remunerate flexibility when required. Different types of business models and deals will enable broad implementation of DR programs, while market regulation will remove all barriers for providing AS from each qualified party. Moreover, the coordination between Transmission (TSO) and Distribution System (DSO) Operators puts the focus on service provision from resources connected to the distribution network which will enhance AS market liquidity.

To summarize, the research community is looking into the flexible behaviour of the prosumer to achieve the goals set in low-carbon policies. Unlike traditional pricing mechanisms with flat rate or two-tariff pricing and traditional supplier-final customer long-term contract with predefined electricity prices, the objective of the thesis is to propose, model and critically evaluate innovative types of pricing mechanisms which stimulate the flexible behaviour of final customers and prosumers:

- Flexible prosumers are modelled as members of the energy community who share their energy surplus - innovative energy community pricing calculation is conducted in a two-stage process the day after energy delivery taking into account both day-ahead (DA) energy prices and flexibility incentives provided from the community manager which encourage them to follow their preannounced DA schedule.
- Flexible prosumers represented by an aggregator on the market are part of an innovative balancing group (BG) together with a large wind power plant (WPP) - aggregator determines price signals to the prosumers who serve as a buffer between the power system and the intermittent nature of WPP according to the market prices and stimulates their flexible behaviour in order to reduce the electricity cost and the balancing cost.

The scientific contribution of the thesis is divided into two parts:

1. Stochastic model of a flexible energy community with the calculation of internal electricity buying and selling prices based on DA market prices and flexibility incentives.
2. Improvement of cost-sharing calculation methods that are fair to all community members including the method selection process.

1.3 Structure of the Thesis

The thesis is structured as follows:

- Chapter 2 describes electricity trading in a pool environment and reviews current practices in final customer's pricing from predefined long term flat tariff through dynamic pricing stimulating flexible behaviour to p2p trading and providing flexible services;

- Chapter 3 defines and elaborates the mathematical methods and models used in modelling flexible behaviour of prosumers which are utilized in the thesis;
- Chapter 4 highlights the main contributions of the thesis and links them to the related publications;
- Chapter 5 presents the list of all relevant publications;
- Chapter 6 summarizes the author's contribution to the publications;
- Chapter 7 concludes the thesis and highlights the main findings.

Chapter 2

Final customers in the center of energy transition

Low-carbon energy policy puts the focus on reducing greenhouse gas emissions through RES integration. This Chapter gives the introduction to electricity market organization and the changes that liberalization brought. The variable nature of RES requires increased flexibility in the power system. The path towards this lies in unlocking flexibility potential from the end-user side. In line with this, this Chapter focuses on the evolution of final customer behavior, from completely passive entities under flat and two-tariff pricing mechanisms to different dynamic pricing options stimulating their flexible behaviour either individually or aggregated in diverse forms. This Chapter also highlights how the contribution of the thesis fills the main gaps in this research area.

2.1 Introduction in electricity markets

Electricity trading can be divided into two categories, pools and bilateral trading. Bilateral trading is a type of trading on a long-term or a medium-term horizon and includes purchases and sales of specific products. All parties involved in the trading negotiate terms and conditions. The agreement between buyers and sellers includes the specifications about the amount and price, length of the contract, and when the trade is going to be realized. This type of trading is out of the scope of the thesis.

On the other hand, the pool-based environment is characterized with the competition between market players on a short-term basis. Several pools in Europe include Nordpool [4], MIBEL [5], Epex [6], HUPX [7], CROPEX [8]. The main benefits of pools bring reliable electricity price, more possibilities and higher security due to transparent offers, more efficient electricity trading due to less work involved in closing deals compared to the bilateral trading, reduced counter-party risk and diverse risk mitigation opportunities, congestion management in

the transmission network provided by the TSO.

Pools are characterized with liquidity, competition, and openness, non-discriminatory treatment and anonymity. The liquidity measures the number of submitted bids and offers from market participants. The liquidity is a very important characteristic in the small market environment where manipulation of price is taken out by a major market player. To increase liquidity, numerous entities should be involved in the market together with the integration of neighboring markets via a market coupling mechanism. To ensure efficient market operation, markets should be fully opened and liberalized. In order to avoid market distortions, none of the market participants should have a special treatment, i.e. all market participants should be treated equally. Non-discriminatory and autonomous market participation has to be ensured.

Market parties involved in trading are divided into seven categories:

1. Producers - own production units for electricity generation. Producers sell electrical energy on the markets or sign a bilateral contract to sell energy directly to the retailers or consumers. They can be divided into conventional power plants and non-dispatchable RES.
2. Consumers - purchase electricity in the markets or sign a bilateral contract with the retailer or directly with producers.
3. Retailers - provide electricity to the consumers who do not participate in the market nor sign a bilateral contract with the producers. Their main goal is to maximize the profit from selling energy to the consumers.
4. Market Operator - usually a non-profit market player in charge of the market operation as a whole. Some market operators in Europe operate as separate legal entities, such as Borzen (Slovenia), ELEXON (UK), SEMO (Ireland), APCS (Austria), HROTE (Croatia), OKTE (Slovakia), OTE (Czech Republic), OPCOM (Romania). Market operator is responsible for the calculation of the imbalances of the balance responsible parties (BRP), distribution of all market information to the TSO, keeping records of all market participation contracts and establishment agreements of BG, preparation of a daily market plan, concluding purchase and sale contracts, and taking a balanced responsibility for the electricity generated by privileged producers using a feed-in tariff.
5. Market regulator - supervises the operation of the electricity market ensuring the competitiveness and adequate market functioning. The market regulator is in charge of the development of market rules, codes, and standards, registration of market participants, monitoring and enforcing compliance to the rules, codes, and standards, monitoring market behaviour, eliminating the abuse of market power.
6. Prosumers - relatively new market participants represented as active consumers who self-consume the electricity they produce and sell the excess to the grid (in case of insufficient onsite energy production, the required amount is supplied from the grid). Some examples

of prosumers are residential prosumers, community/cooperative prosumers, commercial prosumers, and public prosumers.

7. Aggregator - optimizes the use of aggregated distributed energy resources (DERs) with a goal of electricity or AS trading. Aggregators can be involved in providing DR programs, a range of AS, ramping requirements, and local flexibility.

The pool in European markets usually includes DA markets, adjustment markets (such as intra-day markets), and balancing markets. In the DA market, sellers and buyers submit their bids and offers for the next 24 hours in a closed auction. Orders are matched under the goal of social welfare maximization. Network constraints are usually considered in the market clearing process in order to avoid congestion and other contingencies. DA markets are usually closed 12 hours prior to the beginning of the day for which the bids are submitted. Hourly cleared prices are announced one or two hours after the market closure, while all buyers and sellers are informed about their individual results. The physical obligation of delivering (selling) or consuming (purchasing) electricity is enforced by the imbalance settlement process. The intra-day markets work together with the DA market in order to enhance the supply-demand balance with trading closer to the physical delivery. Intra-day markets become very popular with the high integration of RES because of their variable nature which can be mitigated closer to the time of physical delivery. Intra-day markets enable market participants to change their DA schedules due to unexpected changes in consumption or production or possible contingencies in the system. Moreover, intra-day markets reduce the need for a reserve. Intra-day markets are continuous markets in which trading takes place approximately one hour prior to the physical delivery (in some cases can be even shorter). The TSO must ensure the balance between the supply and demand, while the balancing market is the final market platform in which the TSO settles deviations after the closure of the intra-day markets. Two balancing markets exist: a balancing capacity market in which producers and consumers submit their bids and offers to deliver balancing energy in RT, and a balancing energy market in which TSO activates the contracts from the balancing capacity markets. Each market participant is part of a BG, either individually or with other entities. The BG has its representative responsible for the imbalances of the group. BRP is financially responsible for the imbalances and helps the system to be balanced. The imbalance represents the difference between the allocated volume and the final position in the market. Imbalance settlement is a financial mechanism that charges or pays balance responsible parties for their imbalances. It ensures that costs of energy deficit or excess are allocated to the market participant which caused the imbalance.

It is necessary to ensure a well-functioning electricity market. Traditionally, energy supply used to be a natural monopoly composed of production, transmission, distribution, and trading. The liberalization in the electricity sector divided these parts into regulated parties with monopolistic behaviour (transmission and distribution), and in competitive parties which are

market-oriented (production and energy trading). In the past, final customers had no or limited type of electricity pricing and supplier options. The liberalization welcomed new energy providers in the market establishing a high level of competitiveness and reduction of electricity prices together with improvement of the service [9]. The following Chapter will introduce the role of the final customer in the market and explain the importance of their flexible behaviour in the low-carbon power system.

2.2 Transition towards the prosumer-oriented power system

Power generation and transport are responsible for almost all global growth of greenhouse gas emissions in the last decade. More precisely, the energy sector (electricity, heat, and transport) accounts for 73.2 % of total emissions. To reduce the harmful effects on the climate, it is of significant importance to decrease these emissions and prevent future temperature increase and global warming. The energy sector faces the biggest challenges towards sustainable development. The energy production from fossil fuel power plants has been under receding. Output from coal-fired power plants is now at 40% of the levels measured in 2000 in the European Union [10]. The transition towards carbon-neutral energy production has doubled the share of RES in gross final energy consumption in the last 15 years. Wind and solar energy are the main leaders in the low-carbon transition, i.e. at the end of 2020 total wind and solar energy installed capacity was 732 GW and 623 GW (18% and 6% increase compared to the previous year) [11]. This brings difficulties not only for the TSO but also for the DSO. Due to their intermittent nature and variable production, integration of RES requires increased flexibility in the power system together with innovative approaches in power system planning and operation.

Traditionally, passive distribution networks used to be planned according to the *Fit and forget* approach. This approach implies resolving all issues and network problems at the planning stage. The network was reinforced to fit all possible scenarios, even the rare ones with low duration. This usually led to network oversizing. Passive distribution networks were characterized with low monitoring and little or no information exchange between the DSO and TSO. This approach requires low flexibility and control, however, in distribution networks with a high penetration level of RES significant investment in the network are required in order to cater all possible contingencies. This makes *Fit and forget* approach the least economic option.

Faced with new challenges, such as uncertainties in RES generation and bi-directional power flows, the DSO is required to change the planning and operation strategies in order to ensure reliable and secure energy supply in the most efficient way. *Active Distribution Network Management* combines planning and operational solutions and implies RT monitoring and control in the network. In the low-carbon power system, flexibility is also required at the distribution level and can be provided from different low-carbon technologies, such as BES,

EV, cooling and heating within HEMS, but also from grid-based solutions, such as On-Load Tap Changer (OLTC) transformers. If not required for local voltage control and congestion management, the aggregated flexibility options can be offered to the TSO for maintaining the frequency, congestion management, and voltage control in the transmission network. In order to ensure that counteracting services are not activated, TSO-DSO coordination mechanisms is required. This implies significant information exchange in RT and thus the investment in new ICT infrastructure.

As fossil-fuel power plants are being replaced, traditional sources of flexibility are not sufficient to accommodate broad integration of RES characterized with the high level of uncertainties. In line with one of latest energy directives [12] which emphasize that all final customers should be treated in a non-discriminatory fashion and enable their market participation (energy markets and AS markets), academic researchers and scientists are looking for innovative solutions which will stimulate the flexible behaviour at the final user's side in order to lower electricity cost and at the same time contribute to the optimal network operation. To ensure the adequate provision of flexibility services, passive final users need to become active network and market participants. HEMS are necessary to provide the benefits to both homeowner and utility. The role of HEMS is to monitor and control the energy consumption in order to adapt the behaviour of household appliances based on the price signal or flexibility incentives received from the system operator or aggregator. The following Chapter will describe different types of flexibility options under DR programs that induce changes in the final user's consumption profile.

2.3 Demand response programs

The EU tends to promote fair competition in the energy sector by allowing final customers to freely switch their electricity suppliers and choose between different pricing options. This will foster internal market liberalization which will gradually open the door to final customers' market participation.

The changes the liberalization brought had a significant impact on the final customer. With increasing retail competition, electricity suppliers had to modify the prices and contract terms in order not to lose their customers and attract new ones. These modifications are firstly seen in price reduction with the predefined fixed contract duration (12 months or longer) and later in the creation of different price signals during the predefined block of hours in a day, so-called tariffs system. Nowadays, electricity suppliers with more than 200 000 customers are obliged to offer at least one dynamic electricity prices option to final customers [12]. Dynamic electricity price contract is defined in Clean Energy Package [12] as an electricity supply contract between a supplier and a final customer which reflects spot market price or DA market at intervals at least

equal to the market settlement frequency. Dynamic prices are an advanced type of implicit DR programs. Dynamic prices are divided into several categories:

- Time-of-use (ToU) pricing,
- Critical peak pricing (CPP),
- Real-time (RT) pricing,
- Peak-time rebates (PTR),
- Step-wise power tariff (SWPT),

ToU pricing implies different prices during the day for a fixed amount of time predefined in the contract (e.g. two-tariff pricing refers to lower electricity prices during the night and higher during the day, while three-tariff pricing refers to three different levels of price during several hours in a day). CPP refers to a significant increase in electricity prices during peak hours on critical days. These extremes are announced in advance and can occur a limited number of time in a year. RT pricing refers to the price alternation in each hour during the day reflecting the situation in the energy market. PTR provide a rebate for active consumers who agree to shift energy usage during peak hours. In SWPT electricity quantity is divided into steps. Each step corresponds to a unit price which increases with steps. The clearing price per month is equal to the sum of the product of consumed electricity quantity in each step and its corresponding price.

Different goals are achieved with dynamic electricity pricing. Cost reduction with PV and BES installation is achieved under ToU pricing compared to the case without DERs in [13]. The profitability of PV investment under different pricing options has been described in [14], [15]. Machine learning models under ToU pricing focus on peak load reduction and the final user's cost together with carbon emissions and generation cost reduction [16] and [17]. Reduction of electricity consumption per month and maximum hourly consumption, as well as the difference between peak-valley have been investigated in [18] under ToU and SWPT pricing. The cost of final users and peak load reduction is achieved with SWPT, RT, ToU pricing in [19], [20], [21], [15].

These diverse pricing options are part of implicit (price-based) DR programs, i.e. final customer reacts to the price signal to achieve lower electricity cost. On the other hand, in explicit (incentive-based) demand-side flexibility final customers change their consumption according to the request by TSO for activation of balancing energy or by DSO for resolving a network constraint violation. They can receive a diverse type of incentives, such as direct payments, bill reduction, the possibility of energy control, and energy savings. It is divided in four categories [22]:

- Direct-load control (DLC) programs,
- Curtailed (CL) and Interruptible programs,
- Emergency,

- Market-based.

The demand of the final customer involved in the DLC programs is directly controlled by the utility and can be curtailed or shifted during critical peak load periods. The maximum amount of load curtailment, the maximum number of service activation in a year, and duration of the service are predefined and agreed in the contract. CL and interruptible load programs are not directly controlled by the utility. Final customers who agreed to participate in these types of programs are notified in advance to switch off or shift their appliances. The notification for load adjustment can be received on a minute, hour, or DA basis, depending on the terms agreed in the contract. Interruptible programs are suitable for larger consumers (either commercial or industry) who receive lower prices during normal operation and additional incentives when the load is interrupted. If the load curtailment or load interruption is requested by the utility and the service is not delivered, final customers involved in the program can face the penalties.

Incentive based DR are used for peak-shaving [23], [24], [25], for mitigating congestion and unallowed voltage fluctuations [23], [26], for the system operation cost minimization [27], [28], greenhouse gas emission minimization [29], energy procurement cost minimization [27], [30], [25] and RT deviation minimization from predicted DA schedule [31], investment cost minimization [32], line loss reduction [33], minimization of load curtailment[34], providing frequency reserve[35], [36] and minimization of RES curtailment [37].

Market-based DR is organized through an independent aggregator or an aggregator acting as a supplier and a flexibility service provider (FSP). Due to their small installed power, individual market participation of small final customers is not possible and different forms of aggregation are established. The following Chapter will describe different types of aggregation and the benefits for final customers involved in the aggregation.

2.4 Aggregation of final customers

Aggregation is defined in the EU Directive on common rules for the internal market for electricity as a combination of loads of multiple final customers or generated electricity which is sold, purchased, or auctioned in any kind of electricity market by a natural or a legal person [12]. Different forms of final customers and DERs gathering have been studied in the thesis:

- Microgrids,
- Energy communities,
- Virtual power plant or aggregators.

2.4.1 Microgrids

A microgrid is a low-voltage (LV) distribution network which can be operated autonomously (in an island mode) or can be connected to the main grid. When the microgrid is connected to the main grid, it exchanges energy with the rest of the network through the transformer. When operating in an island mode, the microgrid supplies its own demand using its own distributed generation (DG) [38]. The goal of energy management in the microgrid is a smart and coordinated operation which ensures minimal operation cost and minimal deviations from predefined DA schedule with BES [39]. The impact of DR programs in microgrid operation was investigated in [40]. Emergency DR is the best program in a critical situation and brings the lowest cost for the final users and acceptable cost for the microgrid operation. On the other hand, RTP results in the lowest operational cost and the highest cost for final users. Operational costs can also be minimized with optimal scheduling of EV charging used for peak load reduction and load curve modification, while the responsive loads serve as a compensation reserve for uncertain wind and PV generation [41]. The optimal operation of DERs in a microgrid is studied in [42] to fulfill the goal of critical loads supply with minimum community social welfare loss.

Microgrids can provide a wide range of AS to the main grid if they are operated in the grid-connection mode: frequency control support, voltage control support, congestion management, reduction of grid losses and improving power quality. If operated in an islanded mode, the microgrid is responsible for the frequency and voltage stability which are necessary for the secure and stable microgrid operation.

Islanded microgrids have less inertia compared to the microgrids connected to the power system. To prevent the harmful effects of contingencies, various control methods are necessary for frequency and voltage control.

Power quality in the microgrid related to the different DG system integration was discussed in [43]. Power quality in microgrids is divided into voltage quality (voltage variation, voltage unbalance, harmonic distortion of the voltage waveform, phase balancing), continuity of supply (type and duration of interruption, voltage level of fault, type of continuity indicator), and commercial quality. Power-sharing and voltage regulation with a consensus-based algorithm is proposed for direct-current (DC) microgrid in [44]. To lower the imbalance cost in RT resulted from imperfect information while bidding on DA market, RES and different flexibility sources (such as BES or a pumped storage plant) can optimally schedule their operation in the microgrid. This type of joint market participation is seen as an option for uncertainty mitigation but also opens the door for Spinning Reserve and Fast Response Reserve provision [45].

There are several real-life microgrid examples reported in the literature [46], [47]. Boston Bar – BC Hydro, Canada was built as an answer to frequent daily power outages. UW microgrid in the USA is used for modelling control issues in integrating diesel generators into microgrids that can also include converter-based sources. Bronsbergen Holiday Park in the

Netherlands consists of more than 200 holiday homes with 108 rooftop PV systems and central energy storage controlled with a centralized approach with the possibility of automatic isolation and reconnection. The Residential Microgrid of Am Steinweg in Stutensee, Germany, was built as part of DISPOWER project. The load is supplied from 28 kW CHP unit and 35 kW PV installation, while the microgrid counts 101 apartments and 100 kW BES. The microgrid is capable of islanded operation for a longer period of time. CESI RICERCA DER DC LV test microgrid was built in Italy as part of Microgrid projects. The microgrid has several DERs and controllable load under centralized control. Flywheel is installed for improving the power quality, while BESs serve for proper system operation during fast transient dynamics in the island mode. Kythnos island microgrid in Greece supplies 12 households and 53kWh BES from 10 kW PV and 5kW diesel generator. Battery management is achieved with grid frequency combined with a frequency droop concept as a communication signal. Laboratory-scale microgrid system at the National Technical University of Athens in Greece consists of two PV systems, a wind turbine, BES, controllable loads, and a controlled interconnection to the local LV grid. The voltage sources converter connects the BES with the grid and is used for voltage and frequency regulation in islanded operation. Moreover, the Faculty of Electrical Engineering and Computing University of Zagreb is currently forming a microgrid [48]. It consists of multiple Li-ion battery storage (38+18+18 kWh modular battery packs, 6x2.5 kW/6 kWh residential battery packs), supercapacitor energy storage (5 kW / 0.1 kWh; 96 Vdc/83 F), multiple PV strings (4x12.5+3x10+1x4 kW for a total of 84 kW installed capacity), controllable AC and DC loads, DC drive driven engine that simulates a 15 kW thermal power plant (busbars, protection equipment, metering equipment), 20 kW hydroelectric power plant with a Pelton turbine (with turbine governor and rated flow of 27 liters/s).

2.4.2 Energy communities

An energy community can be represented as collective energy actions with an open and democratic participation which bring benefits for its members. The main legal framework distinguishes two types of energy community: renewable energy community (REC)[49] and citizen energy community (CEC) [12]. There are several differences between REC and CEC. The membership issue is more strictly regulated in REC. The participation of private undertakings in REC cannot be their primary commercial or professional activity. Moreover, members of REC must be involved only in renewable energy projects which are owned and developed by the community members. CEC can involve also other technologies, not only RES. CEC is limited only to electricity, while REC can involve other energy carriers. CEC has no geographic limitation, while in REC stakeholders must be located close to renewable energy projects owned and developed by REC [50]. In line with this, the thesis focuses on CEC and investigates the benefits of its members arising from their collaboration.

Exchanging energy in the community can be divided into centralized and decentralized trading. The centralized energy sharing involves a central entity, a CM, who is in charge of household flexible appliances and determines the prices for each community member. On the other hand, in a decentralized approach, each community member decides on its own trading actions, i.e. volume and price in the transactions. In the decentralized approach, final customers do not need to share any information about their energy preferences and consumption, which reduces the communication burden, while the mathematical models include energy optimization only for one final customer which makes it easy to solve. However, centralized approach is simple to implement and encouraging for the final customer due to their limited involvement in the flexible scheduling of appliances.

The centralized approach was investigated in several papers: [51], [52], [53], [54], [55]. The work in [51] investigates demand-side management and low carbon technologies (BES and RES) in peer-to-peer (p2p) trading. To address the cost fairness problem, the model uses Pareto optimality which ensures that all participants involved in p2p trading face lower electricity cost compared with their individual cost. An internal community price calculation based on Supply-Demand Ratio taking into account the willingness of load shifting is investigated [52]. The problem is formulated as a bi-level optimization model in which the upper-level calculates the internal prices and the lower-level minimizes the cost of each prosumer. The paper [53] proposed two internal market designs comparing the overall community profit with private and common BES. Compared to the baseline case without BES, the energy community can save up to 31% with BES and p2p trading with private ownership and up to 24% with commonly owned BES. Participation in a local energy community is not only beneficial for its members in terms of reducing the electricity bill. The paper [54] focuses on providing frequency restoration reserve from the local energy community that share low carbon technologies (PV, EVs, BES). The service provision is conducted in a two-stage process. The CM determines the flexibility in the DA stage which can be submitted to the balancing service provider. The real-time operation of community minimizes the cost considering the flexibility reserved in the first stage. The results demonstrate that higher utilization of BES in the DA stage is less profitable. However, the case with lower utilization is more profitable than the baseline case in which the community does not provide any reserve. P2p energy transaction which maximizes social welfare is investigated in [55]. P2p trading in the community is decomposed into two parts: pair matching to maximize the profit and profit balancing between the matched pair.

The decentralized approach was investigated in following papers: [56], [57], [58], [59], [60], [61], [62], [63], [64], [65], [66].

Energy trading in the local energy community based on a coalitional game is discussed in [57]. The results show that nucleolus-based solution fairly redistributes cost among community members, while the grand coalition is the most profitable coalition which benefits increase if

the community is involved in peak shaving and valley filling.

A decentralized energy community market clearing problem considering both DA decisions and RT actions in [58] is solved with the Alternating Direction Method of Multipliers (ADMM). Prices for energy traded in the community are set between purchasing and selling price which are set by the supplier. The internal prices are lower when more PV generation is available in the community. The profit sharing between community energy storage and final customers is based on Nash-bargaining game and solved in a distributed fashion using ADMM in honest and cheating participation [59]. A solution based on a cheating equilibrium guarantees stable energy cooperation.

Centralized energy trading between community energy storage and prosumers is compared with the competitive approach and benevolent approach in [60]. In the centralized approach, the total payments of the community are minimized. In the benevolent approach, the storage operator is regulated by the final users to connect their energy requirements with storage characteristics, while in the competitive approach the storage acts firstly and the final users respond to this action (non-cooperative Stackelberg game). The results show that the competitive operation of energy storage is the best-proposed solution. DA scheduling of flexible appliances with minimization of balancing actions in the community in centralized and decentralized approach based on ADMM is proposed in [61]. The results show that both types of community trading are beneficial for final customers compared to individual energy exchange with the grid, however, it is emphasized that the decentralized approach requires only the information containing the volume of energy exchanged with the grid. The voltage regulation with DR management in the energy community is proposed in [62]. The problem is solved as Stackelberg game in which community energy storage leads the game maximizing its revenue, while prosumers follow minimizing their energy cost. The results show reduced peak energy demand and less storage capacity in the decentralized energy sharing approach.

A risk aversion energy sharing model is proposed in [63] based on blockchain technology and non-cooperative game. P2p trading in the community based on Stackelberg game-theoretic approach distinguishes two competitions during the trading process: price competition among sellers and seller selection competition among buyers [64]. P2p trading shows significant cost reduction compared to the baseline case without DR programs and p2p trading. The interactions between an integrated community energy system, prosumers, and the wholesale electricity market are proposed in [66]. The problem is solved in a bi-level optimization in which the community energy system in the upper-level plans an optimal operation of PV and storage system interacting with prosumers and the market, while prosumers minimize their cost in the lower-level.

The most advanced energy communities in Europe are [67]:

- Bioenergy Village Juhnde - a German cooperative whose goal was to ensure self-sufficiency

in energy consumption in Juhnde village. 70% of heating demand and all electricity demand is supplied by a 7000kW CHP generator on biogas resulting in 60% CO₂ reduction and improving local sustainability.

- Brixton Energy - a cooperative in London in which members have invested in 50 MW of solar capacity (each investor receives an interest equal to approximately 3% of their investment). The produced energy is firstly shared between the buildings involved in cooperation and the rest is sold to the grid.
- Energy Cooperative of Karditsa - a civic cooperative whose focus is put on producing energy from different types of biomass (agro-biomass, forest, and urban biomass) to serve local demand.
- Green Energy Cooperative - a cooperative established in Croatia involved in investment and energy efficiency project focused on a citizens community and blockchain technology.
- Jurassic - a cooperative society in France in which RES installations are co-financed by its members, either companies or individuals. 3 MW of installed wind and solar capacity supplies 2000 households (without electric heating).
- Coppertino - the first cooperative in Portugal aiming to involve citizens in renewable and decentralized energy future. The community members invest in diverse RES projects improving the local economy development and creating social values.
- Som Energia - the first REC in Catalunya, Spain promoting a 100% renewable energy model. The members of the community pay the deposit fee when enrolling in the cooperative and have access to the electricity from existing RES in the community (the fee is refunded if the member decides to leave the community). Each member who invests in the RES can expect a 4% to 7% of investment rate.
- Sifnos Island Cooperative - the first energy-autonomous island in the Mediterranean in which energy will be supplied from RES owned and shared by the citizens of the island energy cooperative.
- Edinburgh Community Solar Co-operative - PV installed on 25 buildings in the city with the generation capacity of 1.38 MW which produces 70% of the electricity used in the community and support improvement of energy security, reduce greenhouse gas emissions (1000 tones of carbon dioxide reduction since 2019) and help to foster sustainable development in Edinburgh.

2.4.3 Virtual power plants or aggregators

The recent trend in a price decrease of low-carbon technologies and increased awareness of final customers' flexibility potential open the door for aggregator participation in AS provision. In a Virtual Power Plant (VPP), decentralized units in a power network are linked and operated by a

single, centralized control system called an aggregator. The aggregators need to ensure simple access and a high level of automation in order to attract diverse final customers and act as a FSP according to the power system's needs.

Four different types of market models for aggregators (or VPP) are distinguished based on different focus and complexities [68]:

- Model 0 - aggregators are already existing market entities, either electricity suppliers or BRPs and flexibility is not separated from the classic electricity supply.
- Model 1 - independent aggregator in charge of providing frequency stabilization, but not responsible for electricity supply. Due to limited duration and volume of frequency stabilisation service, there would not be a significant imbalance cost incurred by flexibility activation from the aggregator's side.
- Model 2 - aggregator cooperates with existing BRP and is not responsible for electricity supply. Imbalance costs are directly covered by the aggregator.
- Model 3 - aggregator cooperates with the electricity supplier, i.e. it is responsible for both flexibility service provision and electricity supply. The main advantage of this model is a separate settlement of the customer's baseline and flexible load.

Diverse aggregator's (VPP's) business models have been investigated in the academic literature. The market participation of the aggregator can be divided in several categories:

- energy market participation: [69, 70, 71, 72, 73, 74, 75],
- frequency service provision: [76], [77], [78], [79], [80], [81],
- non-frequency service provision (voltage control and congestion management): [82], [83], [84], [85], [86], [87], [88].

In [69] the aggregator receives DA market price and interruptible load tariff and optimizes the energy consumption of flexible residential load through smart meters. The model categorizes different types of households such as shiftable load, interruptible load, adjustable load (such as air conditioner), uninterruptible load (such as washing machine and rice-cooker), and EVs. DR was tested for ToU, RT pricing and CPP and results show that the flexible consumption not only reduces the electricity cost of the final customer, but also decreases the peak load and the difference between peak and valley energy consumption. The authors in [70] propose a business model for an aggregator in charge of prosumer's flexible units taking into account DA market prices, grid tariffs, use of fuels in an industrial plant, and imbalance penalization. Flexible household units are space and water heating, while CL is a low-priority load. Shiftable load in the industrial plant is wood fiber production. The paper focused on reducing the imbalance penalization with flexible consumption and the results show that the idea developed in this paper fulfills the requirements of the TSO in power balancing planning. The participation of EV aggregator as a price-taker in DA market considering robust optimization and uncertainties together with possibilities of V2G was investigated in [71]. The approach modelled in this paper

achieves lower charging costs compared to the deterministic solution or unidirectional charging and conventional charging.

Due to a high number of final customers providing flexibility, the work in [72] focuses on aggregator's participation in the DA energy market based on clustered optimization. The model described in the paper is based on a two-step approach. In the first step a centroid-based clustering algorithm computes the aggregated flexibility, while the second step optimizes supply and demand bids. The results show that clustering decreases the number of variables and constraints in the optimization problem which has a positive effect on reducing computational time (in deterministic approach from 41 s to 0.5 s and in two-stage stochastic approach from 7.8 h to 2 min in the case with 10 000 prosumers). The aggregator of commercial consumers (shopping centers, offices, hotels) participates in the DA energy market in order to increase its economic benefits [73] taking into account the comfort set by the end-user. The uncertainty of PV, price, and load is tackled with robust optimization considering the participation of aggregator in DA energy market and flexibility provision from BES [74]. The main conclusion of the paper highlights the importance of including BES aging and uncertainty in the optimization model which decreases the overall aggregator's benefits.

The provision of frequency containment reserve by aggregated residential heat pumps was investigated in [76] distinguishing the effects of availability and reliability on the bid size and revenue. The results show that higher bids and revenues are achieved in the "reliable case" (aggregated bid size 7.9 MW and 1 € revenue per heat pump on a weekly basis compared to the "available case" with 1.7 MW aggregated bid size and 0.22 € weekly revenue). The paper [77] investigates the profitability of BES providing primary control reserve (PCR) in the market environment with the decreasing prices of PCR and BES units under different bidding strategies. Low-risk bidding strategy with minimum storage price results in a higher number of accepted bids, while in high-risk bidding strategy with a smaller amount of flexibility service provision. Financial analysis shows that investment in storage with a fixed price of PCR is profitable if a lifetime is expanded to eleven years and higher drops in PCR prices would not be attractable for investing in storage units. Providing regulating and reserve power by EV can bring financial benefits to the owner ranging from 120€ to 750€ [78] on the annual basis with small or no impacts on the mobility needs. A three-level control structure for providing primary frequency control support by thermostatically controlled loads (TCLs) is modeled in [80] with automated control and intact comfort. The aggregator coordinates and dispatches primary reserve references in the high level. Distribution substations dispatch the control signals to all individual TCLs in the middle level, while the low level implements the frequency control loop. The coordination between WPP and DR aggregators in [81] reduces the revenue loss of WPP with less penalization in the balancing market scheduling up and down reserve from DR aggregator.

To reduce the congestion caused by uncontrolled EV charging and heat pumps, the work in [82] proposes dynamic tariffs and daily power-based network tariffs to stimulate flexibility potential from controllable electric loads. The optimal charging and discharging of an EV fleet with the goal of reducing charging cost and providing voltage control and frequency regulation taking into account BES degradation is proposed in [84]. The results show that voltage control is more beneficial for the aggregator, while the frequency support provision reduces the charging cost of EVs and thus is more financial profitable for the owners. To deal with congestion management and to reduce voltage fluctuations and unallowed voltage deviations, the paper [85] proposes a flexibility exchange strategy that requires minimal power deviations from the final customer side. The collaboration between the DSO and aggregator of DG and EVs in providing congestion-management is proposed in [86]. The centralized approach is compared to the market-based decentralized congestion management and results show that the decentralized approach requires less data exchange and 320% less computational complexity together with lower costs of EVs. To remove congestion in the distribution network, an optimal operation of flexible buildings is proposed in [87] considering DA distribution local marginal prices with minimal information exchange between the system operator and an aggregator. The paper [88] describes the benefits of dynamic power tariffs over dynamic tariff with fixed power tariff for reducing congestion in the distribution network from DR. Unlike dynamic power tariff, dynamic tariff requires the use of price sensitivity coefficients which can, if not chosen properly, cause the failure of dynamic tariffs.

The previous section gave a comprehensive review of multiple services provided by the aggregators in the academic literature. However, it is important to emphasize that academic researches in the field of aggregators and DR programs serve as a substrate for real-life applications. The aggregators, entities that operate VPP, Kiwi power [89], Next Kraftwerke [90], Energy Pool [91], Flexible Power [92], or market places for local flexibility trading [93] provide different flexibility services and bridge the gap between the goals set by low-carbon policies and variable and intermittent nature of RES.

2.5 Connection to the Contributions

The first part of the dissertation critically evaluates the role of the final user in the clean energy transition as elaborated in 2.2, from abandoning passive consumption through becoming flexible users under diverse DR programs described in 2.3 and different forms of aggregation described in 2.4.

The second part of the dissertation, an innovative calculation of internal electricity prices in energy community which ensures lower electricity costs for all community members, is related to Chapter 2.4.2 which is focused on energy communities. Moreover, flexibility incentives

for adjustable consumption which results in lower electricity cost of final users are closely connected to the diverse demand response programs described in 2.3.

The last part of the dissertation is focused on the market participation of aggregator and WPP on DA and balancing market as described in 2.1. This innovative form of BG which consists of flexible prosumers and WPP resulted from an increased need for flexibility which can be provided from the final customer's side as proposed in section 2.2. Different pricing options described in 2.3 are used for end-user cost calculation, while aggregation of final users is related to the 2.4.

Chapter 3

Mathematical modelling and optimization problems

The research described in this thesis consists of three subtopics: evolution of the final customer's role from passive consumers through flexible behaviour and different forms of aggregation to providing AS services to the power system, the effect of local energy exchange between flexible community members on their cost under different pricing mechanisms considering RT dynamic prices and flexibility incentives, and formation of an innovative type of BG in which final users under DR programs with their flexible behaviour reduce the imbalance penalties of RES. To solve these problems, different mathematical optimization models are constructed in this thesis. This chapter will give a brief introduction to different types of optimization problems and mathematical models which are designed in the publications listed in Chapter 5.

3.1 Types of optimization problems

3.1.1 Convex optimization models

A convex optimization problem has a convex objective function, all inequality constraint functions must be convex and the equality constraint functions must be affine. In convex optimization problems any locally optimal point is also a global optimum solution [94]. Convex optimization problems are divided into five categories based on their mathematical complexity:

1. Linear Programming (LP),
2. Quadratic Programming,
3. Quadratically Constrained Quadratic Programming,
4. Second-Order Cone Programming,
5. Semidefinite Programming.

Linear Programming

Linear Programming (LP) problem is defined with linear objective function and linear constraints. The goal is to minimize or maximize a linear function of the decision variables. The values of these decision variables must satisfy a set of linear constraints which must be either linear inequality or linear equality. Each variable has a sign restriction, either positive, negative, or unrestricted. LP is often used to determine the optimal solution in diverse areas. LP is useful to determine the optimal use of resources in the model and improves the quality of the decision making it less subjective. It is useful in the re-evaluation of a basic plan if some conditions changed when the plan is partly carried out [95].

In Mixed Integer Linear Programming (MILP) problem some variables are restricted to the set of positive integers and others are continuous variables. In some real-life examples, some variables have to take an integer value, such as the required number of BES, the location in the grid, the number of cycles of an appliance, etc. Moreover, the MILP problem also implies the use of binary variables whose values can be either zero or one. The use of binary variables is necessary when the optimization problem needs to decide between different solutions from which only one is possible [96]. All mathematical models in this thesis are formulated as MILP problems.

3.1.2 Non-convex optimization models

Non-convex optimization models are described with non-convex objective function and non-convex set of constraints. Non-convex optimization is computationally hard due to multiple local extremes (minimas and maximas), saddle points, very flat regions, and widely varying curvature. They have at least non-deterministic polynomial-time hardness, i.e. they cannot be solved in polynomial time. They cannot be solved with general optimization techniques, each problem requires an individual approach. The most common non-convex problem are neural networks which can be solved with stochastic gradient descent, mini-batching, stochastic variance reduced gradient, momentum, alternating minimization methods, etc. [97]. Non-convex optimization models are out of the scope of this thesis.

3.2 Solving optimization models

Optimization problems can be complex and sometimes cannot be solved in polynomial time or give an exact solution. Unlike exact methods, heuristic optimization problems can be solved in polynomial time and result in an acceptable solution, but sometimes not globally optimal. However, heuristic methods are not flexible, i.e. if a variable is changed or constraint is added into the problem, a hard-coded heuristic model will not be usable and the model requires ad-

ditional changes in implementation. Commonly used heuristic methods are genetic algorithm (GA), particle swarm optimization (PSO), differential evolution (DE), grey wolf optimization, bee colony optimization, etc. On the other hand, exact methods guarantee global optimal solution and their efficiency remains unchanged if any modification is added in the model. The optimization models in this thesis are solved with exact optimization.

3.2.1 Exact methods

Exact methods can be divided into four categories:

1. Optimized Path - The problem defines a real function that adds value to each path that can be defined between two nodes in the network. The goal of optimization is to determine the path with the highest value between two nodes[98]. There are two types of problems in determining the optimal path: unconstrained problems and constrained problems in which the optimal path must satisfy a certain set of constraints. An example of a problem based on a constrained optimal path is the travelling passenger problem. The finite optimal path problem is defined with a finite number of nodes, while an infinite one has an infinite number of nodes. There are two principles of optimality: a strong principle of optimality in which each optimal path is formed by optimal subpaths and a weak principle of optimality in which exists an optimal path formed by optimal subpaths.
2. Branch and Bound, Branch and Price, Branch and Cut - The Branch and Bound algorithm is one of the methods for solving non-deterministic polynomial time hard problems [99]. This group of algorithms is based on counting all possible solutions by storing partial solutions (subproblems) in the tree structure. Unexplored nodes in the tree generate children by dividing the space in which the solution is located, which can be solved recursively (branching). Numerous rules are used to reduce search space that has proven to be suboptimal (bounding). The algorithm gives the best solution from the searched tree as the optimal solution. The tree components have a significant impact on the performance of the algorithm. The search strategy determines the order in which subproblems are searched. The branching method tells how the solution area can be divided to create new subproblems in the tree. Pruning rules prevent searching for suboptimal areas of the tree. The first phase of the Branch and Bound algorithm consists of searching. At this stage, the algorithm has not yet found the optimal solution. The second phase is verification in which the current solution becomes optimal, but there are still unexplored parts of the tree that can be pruned. The current solution cannot be proven to be optimal as long as there are still unexplored parts of the tree.
Branch and Price - The Branch and Price method is used to solve integer programming problems with a large number of variables [100]. This method is based on the omission of individual columns in the linear relaxations of the problem because the optimal value

of some variables in these columns will be zero. In order to check the optimality of the solution obtained by linear relaxation, a subproblem called the pricing problem is solved in order to identify the columns of cost-effective reduced cost. If such columns exist, linear relaxation is re-optimized. Branching occurs if such cost-effective columns do not exist, but the solution does not satisfy the integrity requirements. The Branch and Price algorithm generates columns (column generation) at each node of the branch and bound tree. The efficiency of this algorithm depends on the strength of the relaxation. Poor linear relaxation results in excessive branching and long run times. A large number of variables allows the creation of strong limits of linear relaxation [101]. This algorithm uses special branching selection strategies for defining the price problem. It is important to note that this algorithm is computationally demanding and it is necessary to make a compromise between the quality of the dual values of the solution and the execution speed.

Branch and Cut - The Branch and Cut algorithm is used to solve integer optimization problems where an optimal solution can be guaranteed [102]. This method is based on the Branch and bound algorithm and the cutting plane method. In order to solve the problem of MILP, it is necessary to find solutions to one or smaller subproblems in which some constraints have been discarded. Such simplified problems are called relaxation. The solution to the relaxed problem represents the lower limit to the initial problem. The lower limits can be used when searching the tree to specify additional constraints and get the optimal solution. Each problem can be solved by dividing the space of possible solutions into smaller areas and setting limits to the goal function in each subproblem [103].

3.Constraint Programming - Constraint programming[104] is used to solve combinatorial search problems with sophisticated artificial intelligence techniques, operational searches, advanced algorithms, and graph theory. The user states the constraints of the problem, while a general purpose constraint solver is used for solving optimization problems. Constraints are represented by relations, and the model associates these constraints with variables. The Constraint Satisfaction Problem (CSP) consists of a set of variables defined in a particular domain and a set of relations between those variables that represent constraints. The search algorithm can be complete or incomplete. A complete search involves a systematic search of the solution area and guarantees finding a solution if one exists and can be used if one wants to prove that there is no solution to the problem. General methods and domain-specific methods are used to solve these types of problems [105]. Domain-specific methods are used to implement special-purpose algorithms, such as programs for solving systems of linear equations, implementation of unification algorithms that are the basis of automated technologies proving theorems. General methods deal with the reduction of search space by specific search methods (constrained propa-

gation algorithms). These algorithms achieve different values of local optimums that try to approximate the values of the global optimum. Top-down search methods are used. Constraint programming consists of two phases. In the first phase, the constraints are set, while the second phase is focused on solving the problem. This type of optimization is very flexible because the constraints can be added, moved or changed without affecting the execution speed. There are several built-in methods that make these types of problems easier to solve. Constraint programming is mostly used in interactive graphics systems to express geometric coherence in the case of scene analysis, operational research problems (usually planning problems), molecular biology (DNA sequencing, construction of 3D protein models), electrical calculations (location network failure, network configuration determination, network testing and verification), numerical computation (solving polynomial constraints with a certain accuracy), computational algebra.

4. Dynamic Programming - Dynamic programming is a method for solving optimization problems based on the decomposition of the main problem into smaller and simpler subproblems. The optimal solution of the problem depends on the optimal solutions of the subproblems. Dynamic programming is recursive in nature, but each subproblem is solved only once, and the results are stored to find a solution faster and easier if the recursion is called again for the same value of a particular parameter or variable. Dynamic programming has a bottom-up approach in which a combination of solutions to all subproblems serves to obtain the optimal solution to the main problem. The characteristics of dynamic programming are optimal substructure and overlapping subproblems. If a problem has an optimal substructure, the optimal solution can be defined by recursion. If a model has overlapping subproblems, recursion implementation can be improved by running each subproblem only once.

3.2.2 Heuristics methods

Several heuristics methods often used in power system optimization are described below:

1. Genetic Algorithm - GA is a heuristic optimization method that mimics the natural evolutionary process of natural selection. This method is very often used to solve a number of optimization models. GA begins with the initialization of parameters and the production of an initial population in which all generations are created based on the best individuals of the previous generation. The operators used in this method are called mutations and crossovers. They are applied to the most capable units of previous generations to produce new generations [106]. The process of natural selection begins with the selection of the most capable individuals from the population. They produce offspring that inherits the traits of the parents and will be passed on to the next generation. If parents have better instincts, their offspring will be better than their parents and will have a better chance

of survival. This process is constantly repeated and eventually a generation will be left with the most capable individuals. This procedure can be applied to a search problem. GA is divided into 5 phases: initialization of the population, 'fitness' function, selection, crossover, and mutations. The process begins with a group of individuals called a population. Each of these individuals represents a solution to a problem characterized by a set of parameters (variables) called genes. Genes are combined into chromosomes. Fitness function determines an individual's ability (an individual's ability is considered in the context of competing with other individuals). The probability indicating that individuals will be selected for reproduction is based on an assessment of their fitness. The idea of the selection phase is to select the most capable individuals whose task is to transfer genes to the next generation. Two pairs of individuals (parents) are selected based on the results of their abilities. Crossover is the most important phase in GA. For each pair of parents selected to mate, a cross-point within the gene is randomly selected. Offsprings are created by exchanging the genes of the parents until the crossing point is reached. Some of the genes of the new offspring may be exposed to mutation. This implies that some genes in the sequence may be reversed. The mutation occurs to maintain diversity within the population and prevent premature convergence. The algorithm stops if the population has converged (it does not produce offsprings that are significantly different from the previous generation).

2. Particle Swarm Optimization (PSO) - PSO is a method based on population modeling and social behavior during a flock of birds. The operator is used to improve the individual population using fitness information from the environment. In this optimization method, position and speed are assigned to each individual. When a new optimal solution is found by an individual, other individuals approach it. The speed of each individual is based on the flying experience and the experiences of other individuals [107]. It has been shown that PSO can achieve better results in a faster way compared to other methods. It can also be parallelized. Unlike traditional optimization methods, PSO does not require the problem to be differentiable. It consists of a small number of hyperparameters that are easy to implement. PSO will work for different types of problems when selecting the same hyperparameters, which makes it a very powerful and flexible algorithm. In PSO, a group of particles (potential solutions) is located in the possible search space. Particles do not know where the global minimum is, but all particles have their fitness values estimated by the fitness function. Particles are defined by coordinates in the search space in which they are located and must be in constant motion updating their position in each iteration. The system is initialized by a population of random solutions and seeks the optimal solution by updating the generations. Unlike GA, PSO does not have evolutionary operators like crossbreeding and mutation. The difference lies in the method of generation

update. The speed of movement in the search space is subject to inertia and is governed by the two best values found up to the observed moment. The first value is the best personal solution the particle has found. The second is the best global solution found by a swarm of particles. Thus, each particle has in the memory the best personal solution and the best global solution. The low coefficient of inertia weight facilitates the exploitation of the best solutions so far, while the high coefficient facilitates research around these solutions. If this coefficient is greater than 1, divergence can occur.

3. Differential Evolution (DE) - DE is based on the adoption of a search mechanism during the evolutionary process [108]. It has proven to be an excellent tool for solving nonlinear optimization problems. After the initialization of the population and all parameters, a new population is generated based on the weighted difference vector between the last two members from the previous population. As in GA, mutations and crossovers used to obtain the optimal solution during optimization play an important role. DE can be considered as a type of GAs and evolutionary programming in which the most capable offspring and the appropriate parent compete. DE algorithms are based on little or no assumption about the underlying optimization problem and can quickly explore very large spaces of possible solutions. DE is arguably one of the most versatile and stable population search algorithms showing robustness towards multi-modal problems. The algorithm searches the space by maintaining a population of candidate solutions (individuals) and creates new solutions by combining existing ones according to a specific procedure. Candidates with the best objective values are retained in the next iteration of the algorithm. The process is repeated until the interrupt criterion is met. The main advantage of DE is the fact that it has only three control parameters that need to be adjusted. The performance of a particular optimization problem largely depends on both the test vector generation scheme and the choice of control parameters. The test vector generation scheme is selected firstly, and then the control parameters for a particular optimization problem are adjusted. Finding the right values of control parameters can be time consuming and difficult, especially for more complicated problems. Advanced variants of DE use adaptive and self-adaptive control parameters that are adjusted based on the feedback received during the search process. Most practical optimization problems consist of one or more constraints. Constraint problems are quite challenging to solve because of their complexity and non-linearity.

3.3 Bi-level optimization

Bi-level optimization is a mathematical program in which the main optimization model has another optimization model defined as a constraint, i.e. the program has a two-level optimization task. The upper-level problem is commonly known as a leader problem, while the lower-level

represents a follower problem. In other words, the information determined in the upper-level model is sent as an input parameter to the lower-level. Each model has its own objective function and constraints. As the lower-level problem serves as the constraint in the upper-level, only feasible solutions obtained in the lower-level can satisfy upper-level optimization problem. The mathematical formulation of a MILP bi-level optimization is given with (3.1):

$$\begin{aligned}
 & \min_{x_1, y_1} F_1(x, y) \\
 & \text{s.t. } G_1(x, y) \leq 0 \\
 & \quad H_1(x, y) = 0 \\
 & x_2, y_2 \in \arg \min \{F_2(x, y) : G_2(x, y) \leq 0, H_2(x, y) = 0\} \\
 & \quad x = [x_1^T \quad x_2^T]^T, \quad y = [y_1^T \quad y_2^T]^T \\
 & \quad x \in \mathbb{R}^n, \quad y \in \mathbb{Z}^m
 \end{aligned} \tag{3.1}$$

x is a vector of all continuous variables and y is a vector of all integer variables, while x_1 is a vector of continuous variables in the upper-level, y_1 is a vector of integer variables in the upper-level, x_2 is a vector of continuous variables in the lower-level, y_2 is a vector of integer variables in the lower-level.

There are two approaches developed in mathematical programming for solving bi-level optimization problems [109]:

- classical approaches : single-level reduction, descent methods, penalty function methods, trust-region methods,
- evolutionary approaches: nested methods, single-level reduction, metamodeling-based methods.

The classical approach single-level reduction is used for solving bi-level optimization problem in this thesis, while other methods are out of the scope of the thesis. The classical approach replaces the lower-level problem with Karush-Kuhn-Tucker (KKT) conditions with Lagrangian and complementary conditions.

The mathematical form of reduced bi-level problem into a single-level is given with (3.2):

$$\begin{aligned}
 & \min_{x_1, y_1, \lambda, \mu} F_1(x, y) \\
 & \text{s.t. } G_1(x, y) \leq 0 \\
 & \quad H_1(x, y) = 0 \\
 & \quad \nabla_{x_1} L(x, y, \lambda, \mu) = 0 \\
 & \quad G_2(x, y) \leq 0 \\
 & \quad \lambda \cdot G_2(x, y) = 0 \\
 & \quad \lambda \geq 0 \\
 & \quad \mu \text{ free}
 \end{aligned} \tag{3.2}$$

Complementary conditions introduce non-linearity in the model which is solved with Fortuny-Amat Transformation [110] in which M is a sufficiently large constant and b binary variable used for linearization of condition i (3.3):

$$\begin{aligned} G_{2i}(x,y) &\leq M \cdot b_i \\ \lambda_i &\leq M \cdot (1 - b_i) \end{aligned} \quad (3.3)$$

3.4 Uncertainty modelling

Decision-making in power system planning and operation includes a high level of uncertainty. To handle this issue, several different approaches are used: stochastic optimization, robust optimization, chance-constraint optimization, and online optimization. Stochastic optimization is characterized with different scenarios and their probability of occurrence (the sum of all probabilities are equal to 1). The uncertainty modelling in this thesis is carried out with stochastic optimization. If a two-stage stochastic model is considered, two kinds of decisions are made - *here-and-now* and *wait-and-see* decisions, as shown in Figure 3.1.

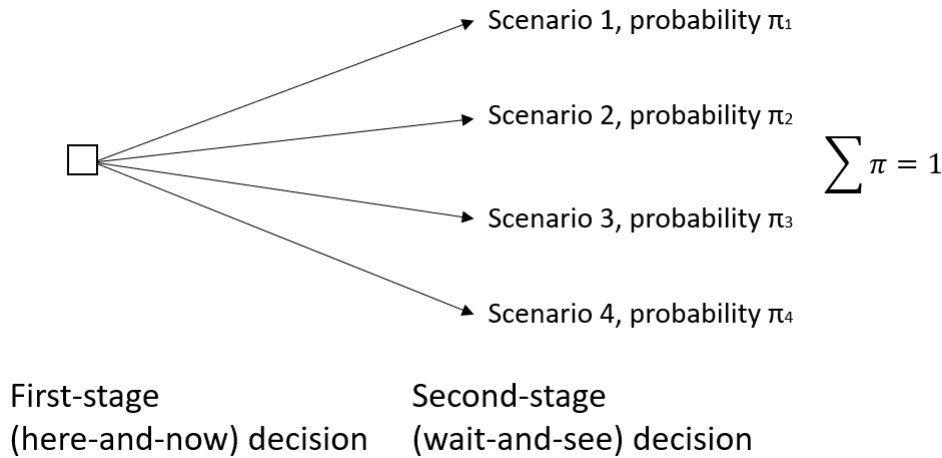

Figure 3.1: Stochastic decision making

The difference between them lies in the different degrees of uncertainty at the moment when the decision is made. *Here-and-now* or the first stage decision is made before the uncertainty is disclosed, i.e. the decision made in this stage considers all possible scenarios that can occur (the stage with imperfect information). The variables representing this decision do not depend on each realization of the stochastic process (scenario). The second stage or *wait-and-see* decision is made after uncertainty is revealed (the decision is made with perfect information). Variables for the second-stage decision are defined for each scenario [111]. Multi-stage problems consider more than two stages, however, they are not used in this thesis.

Robust optimization assumes that the objective and constraints belong to certain sets. The goal is to make the decision that will be optimal for the worst-case objective function and feasible whatever the constraints are. Several types of robustness are considered in the optimization processes: strict, cardinally constrained, adjustable, light, regret, and recoverable robustness [112].

The chance-constrained optimization ensures that the probability of meeting a certain constraint is above a certain level. It gives a high confidence level of the solution due to the restricted feasible region. As the decision has to be made before the observation of random parameters, these models hardly find the solution that guarantees that constraints violation will not occur due to the unexpected random effect. To deal with this, this constraint violation can be balanced in the following stage [113].

Online optimization solves problems with no or incomplete knowledge of the future [114]. Two possible types of problems exist: online problems with multiple decisions which are made sequentially based on a piece-by-piece input and problems in which a decision is made only once.

3.5 Market and final customer modelling in the thesis

Traditional power system planning relied on a conservative passive approach which includes network reinforcement considering all possible future scenarios. With broad integration of RES and transport electrification, this approach becomes very expensive and in some cases inefficient. The transition towards active distribution network management in low-carbon environment is focused on unlocking flexibility potential from DERs and final customers. Different dynamic pricing mechanisms (ToU, CPP, RT pricing, etc.) transform passive customers to active flexible prosumers who are willing to change their electricity consumption behaviour for adequate compensation as described in 2.3. Diverse flexibility sources are considered from the final customer's side: household appliances (shiftable, interruptible), BES, smart EV charging. MILP formulation introduced in 3.1.1 is used in this thesis to model their flexible behaviour. MILP models are solved with Branch and Bound, Branch and Price, Branch and Cut techniques described in 3.2.1.

Bi-level optimization described in 3.3 is used to model the interaction between the aggregator, WPP, and final prosumers. The objective function in the upper-level describes profit maximization of the aggregator which supplies their portfolio and sets dynamic prices to the final users, and WPP which exchanges energy with flexible prosumers in the periods of incorrect DA decision to reduce the balancing cost. The lower-level accepts the prices set in the upper-level and minimizes the cost of flexible prosumers and at the same time exchange the power with WPP when necessary.

Stochastic optimization described in section 3.4 in this thesis is used to deal with the uncertainties of RES production and final user's consumption. PV and WPP generation together with the consumption patterns and final users' habits are modeled with diverse RT scenarios. Aggregators, suppliers, or CM in charge of electricity supply make an optimal decision considering the possible outcome of the diverse scenarios of consumption profile and RES production of their portfolio and procure energy on DA energy market (the first stage decision). When the uncertainty is revealed in RT, they face balancing cost due to the imperfect DA decision. However, diverse flexibility options at the final customer side could be financially stimulated to follow the predefined DA schedule and reduce the balancing cost and at the same time reduce the cost of the final user (the second stage decision). Moreover, the intermittent nature of big WPP can be mitigated with DR programs. BES and diverse DR programs can serve as a buffer between the WPP and balancing market reducing their balancing cost with flexible consumption following predicted DA schedule of WPP.

Chapter 4

Main Scientific Contributions

This thesis is built on the contribution divided into three parts. The first one provides a critical evaluation of the final customer in the clean energy transition. It shows how changes in the final user's behaviour have affected not only their cost but also enhanced the level of flexibility in the power system. The second part investigates the financial benefits for prosumers and active consumers enrolled in energy community trading. The innovative two-stage pricing method based on DA prices and flexibility incentives ensures that all community members are better off within the community compared to the traditional supplier-end user contract. Moreover, the model defines the optimal method selection process. The last part of the contribution proposes a bi-level model of an innovative type of BG in which WPP reduces the uncertainties of their production through energy sharing with flexible final users.

4.1 Critical evaluation of the final customer role in low-carbon energy transition

The liberalization opened the market for new entities which expanded the opportunities for the final customers with different supplier's and pricing options. The critical evaluation of the final customer behavior and cost under different pricing mechanisms has been conducted in [P₃], [P₄], [P₆], [P₈], [P₁₁]-[P₁₃]. Incentivized with reduced investments and competitive prices for selling energy, completely passive final customers started to invest in different low-carbon technologies. In order to achieve lower electricity costs, they are abandoning the flat tariffs and enrolling in different dynamic pricing options. The behaviour of the final customer and the return on investments under different pricing options in several European countries have been investigated in [P₃] and [P₈]. The objective function minimizes the cost of the final customer with different low-carbon technologies (EV, BES, PV, shiftable appliances). The resolution in the MILP model was hourly-based with one-year horizon. Low-carbon technologies embedded at the final customer's side can also be used for flexibility service provision as modeled in [P₄]

and [P₁₁]. Flexible behavior of final customers can be used for local congestion management and voltage control resulting in deferred investment in the network reinforcement. Moreover, local FSPs can be aggregated and provide their service not only to the DSO but also to the TSO. In order to prevent the distribution network constraint violations and the activation of counteracting services, coordination mechanism between the TSO and DSO has been developed in [P₁₃].

4.2 Innovative pricing method for calculation of internal electricity prices in the energy community

The second part of the contribution focuses on the aggregation of flexible consumers and prosumers in energy communities with the possibility of internal energy sharing as proposed in [P₁], [P₉], and [P₁₀]. With the gradual abandonment of feed-in-tariff for households PV installations, suppliers are setting lower selling prices compared to the buying price in order to mitigate the risk of the intermittent nature of RES and ensure adequate profit margin. This does not incentivize prosumers to sell their excess PV production. Sharing excess energy with the neighbouring final users through p2p trading arises as a better alternative. The contribution of the thesis is built on upgrading the cost-sharing mechanisms in energy community p2p trading accounting for DA energy prices and flexibility incentives. Instead of paying the balancing fee for each consumed kWh of energy as it is declared in the traditional supplier-end customer contract, the model proposes incentives for flexible behaviour which stimulate prosumers to follow their predefined DA schedule. This contributes to the overall system balancing. Unlike traditional mechanisms for the internal price calculation in energy community which are based on the total consumption and total production volumes in specific hours, this model considers net-load values which bring additional savings for the community members. The cost minimization of the energy community is formulated as a centralized stochastic MILP model considering different types of communities in size and type of consumers. The cost allocation is executed the day after energy delivery and does not interfere with the optimization algorithm which makes it simple to solve and computationally tractable. The cost allocation is performed as a two-stage process that guarantees lower electricity costs for all community members. In the first step the internal buying and selling prices are calculated under three cost sharing methods Mid-Market Rate Net (MMRN), Bill-Sharing Method Net (BSMN), and Supply-Demand Ratio Net (SDRN). If any member of the community faces higher electricity cost compared to the case with their traditional supplier's contract, the second stage reallocates the financial benefits gained from community energy sharing and ensures low electricity cost for each community member, regardless their energy preferences and low-carbon technology installed. The model proves that BSMN method is the exemption from the fair cost allocation. Prosumers with ex-

cess PV production will face higher costs in the community trading compared to the traditional supplier's contract due to the free energy sharing between community members.

4.3 Bi-level model of Energy Sharing in Aggregator-Wind Power Plant-Flexible Prosumers Balancing group

The last part of the contribution focuses on the design of an innovative type of BG in which the aggregator of flexible users jointly participates on the market together with the WPP in order to increase the profit from energy supply and at the same time to reduce the WPP's imbalance penalties arisen from an imperfect prediction on DA market. Their joint market participation has been developed as a stochastic bi-level MILP model in [P₂], [P₅], and [P₇]. The upper-level model maximizes the aggregator-WPP profit from market participation (either for energy procurement for final users or selling excess energy from WPP). According to the market prices and RT WPP production, aggregator defines adequate price signals for final users which stimulate BES's charging and discharging at the final user's side in order to achieve a better market position. Moreover, these price signals are affected by the RT production of WPP. When necessary, final users share the part of their BES in order to help WPP to reduce the deviation from the predefined DA schedule. The lower-level accepts these price signals from the upper-level and minimizes the cost of final users. The bi-level model is solved with a single level reduction with KKT conditions for generalized equations describing necessary optimality conditions of the lower-level problem. As the cost minimization model in the lower-level is a convex problem, the lower-level problem is replaced with the necessary optimality conditions. This includes stationary conditions and complementary slackness conditions associated with the inequality constraints. Complementary slackness conditions are not linear and their linearization is carried out with Fortuny-Amat Transformations using the big M method. The electricity price for final users determined in the upper-level is a variable and it is included in the upper-level objective function which makes it non-linear due to the multiplication of two variables (electricity price and final user consumption power). The objective function in the lower-level considers the same term for final user cost minimization and the strong-duality theorem can be applied. According to the theorem, the objective value of the primal problem is equal to the objective value of the dual problem. The objective of the primal problem of the lower-level is thus replaced with its dual which is linear. This makes the model solvable with any type of linear optimization solvers. The results show that the coordinated approach reduces the imbalance penalties for the WPP and ensures higher profit for the aggregator, but at the same time lower cost for final users compared to traditional two-tariff pricing contract.

Chapter 5

List of Publications

The publications relevant for this thesis and considered as the main contributions are divided into two sections: journal papers and conference papers. These papers are chosen due to their close connections with the final customers modelling in the transition towards the carbon-neutral power system. Several papers are omitted from the list below, however, they can also be presented as a part of the thesis. Those papers cover active distribution network modelling which is necessary for the low-carbon technology integration. The interested reader can find them under Chapter 7.2.

5.1 Journal Papers

Published

- [P₁]M. Gržanić, J. M. Morales, S. Pineda, and T. Capuder, "Electricity cost-sharing in energy communities under dynamic pricing and uncertainty, " *IEEE ACCESS*, pp. 1-18, 2021, ISSN: 2169-3536, DOI: 10.1109/ACCESS.2021.3059476
- [P₂]M. Gržanić and T. Capuder, "Coordinated scheduling of renewable energy balancing group," *International Journal of Electrical Power & Energy Systems*, pp. 1-10, February 2021, ISSN: 0142-0615, DOI: 10.1016/j.ijepes.2020.106555
- [P₃]M. Gržanić, T. Capuder, N. Zhang, W. Huang, "Prosumers as active market participants: A systematic review of evolution of opportunities, models and challenges," *Renewable and Sustainable Energy Reviews*, pp. 1-31, November 2021, ISSN: 1364-0321, DOI: 10.1016/j.rser.2021.111859

5.2 Conference Papers

Published and Presented

- [P₄]M. Gržanić, T. Capuder, and S. Krajcar, "DSO and Aggregator Sharing Concept for Distributed Battery Storage System," in *2018 IEEE International Conference on Environment and Electrical Engineering and 2018 IEEE Industrial and Commercial Power Systems Europe* IEEEIC / I&CPS Europe, 10.1109/IEEEIC.2018.8493680
- [P₅]M. Gržanić and T. Capuder, "Bi-level modelling approach to coordinated operation of wind power plant and PV-storage energy community," in *2018 IEEE International Energy Conference ENERGYCON*, 10.1109/ENERGYCON.2018.8398844
- [P₆]V. Salapić, M. Gržanić, and T. Capuder, "Optimal sizing of battery storage units integrated into fast charging EV stations," in *2018 IEEE International Energy Conference ENERGYCON*, 10.1109/ENERGYCON.2018.8398789
- [P₇]M. Gržanić and T. Capuder, "Model zajedničkog sudjelovanja aktivnih kupaca i obnovljivih izvora na tržištu električnom energijom," in *6.(12.) savjetovanje HO CIRED-a*, 2018, Opatija, Hrvatska
- [P₈]M. Gržanić and T. Capuder, "The Value of Prosumers' Flexibility under Different Electricity Market Conditions: Case Studies of Denmark and Croatia," in *2019 IEEE PES GTD Grand International Conference and Exposition Asia GTD Asia*, Bangkok, Thailand, 10.1109/GTDAsia.2019.8715888
- [P₉]M. Gržanić and T. Capuder, "Podjela troškova električne energije između članova fleksibilne energetske zajednice," in *14. savjetovanje HRO CIGRE*, 2019, Šibenik, Hrvatska, 2019
- [P₁₀]A. Hrga, M. Gržanić, T. Capuder, and N. Zhang, "Decentralized Platform for Investments and Operation of Energy Communities," in *IEEE Sustainable Power & Energy Conference Grid Modernization for Energy Revolution Peking*, 2019, Peking, China, 10.1109/iS-PEC48194.2019.8975165
- [P₁₁]M. Gržanić, P. Perović, T. Capuder, and M. Bolfek, "Open source tools for integrated operation and planning of flexible buildings and distribution network," in *Mediterranean Conference on Power Generation, Transmission, Distribution and Energy Conversion - MEDPOWER 2020*, 10.1049/icp.2021.1248
- [P₁₂]M. Gržanić, T. Capuder, M. Bolfek, and F. Capitanescu, "A review of practical aspects of existing TSO- DSO coordination mechanisms in Europe and proposal of an innovative hybrid model in ATTEST project," in *IEEEIC International Conference on Environment and Electrical Engineering 2021*, Bari, Italy
- Upcoming Conference**
- [P₁₃]M. Gržanić and T. Capuder, "Collaboration Models Between Distribution System Operators and Flexible Prosumers," in *International Conference on Applied Energy 2021*

Chapter 6

Author's Contribution to the Publications

The contributions of this thesis are achieved during the period of 2017-2022 at the University of Zagreb, Faculty of Electrical Engineering and Computing, Unska 3, HR-10000 Zagreb, Croatia.

The research was conducted under under projects listed below:

- Project Smart Building – Smart Grid – Smart City (3SMART), founded by the European Union funds (ERDF, IPA) through Interreg Danube Transnational Programme.
- Project SUsustainable ConCept for integration of distributed Energy Storage Systems (SUCCESS), founded by Croatian Science Foundation
- Project CROSS BOrder management of variable renewable energies and storage units enabling a transnational Wholesale market (CROSSBOW), funded by the Research and Innovation Program of the European Commission, Horizon2020
- Project Innovative Modelling and Laboratory Tested Solutions for Next Generation of Distribution Networks (IMAGINE), founded by the Croatian Science Foundation (HRZZ) and Croatian Distribution System Operator (HEP ODS)
- Project Punionica elektri čnih vozila s integriranim baterijskim spremnikom - Electric vehicle charging station with integrated battery storage (BatEVCharg), founded by the European Regional Development Fund under Operational Programme Competitiveness and Cohesion 2014 - 2020
- Project Advanced Tools Towards cost-efficient decarbonisation of future reliable Energy SysTems (ATTEST), founded by European Union's Horizon 2020 research and innovation programme

The author's main contribution in each paper is listed below:

[P₁]In the journal paper "*Electricity cost-sharing in energy communities under dynamic pricing and uncertainty*" : literature review, proposal of a two-stage cost allocation mechanism in energy community under dynamic day-ahead prices and flexibility incentives, development of stochastic MILP model in Gurobi environment, input data collection, paper writing and results elaboration.

- [P₂]In the journal paper *"Coordinated scheduling of renewable energy balancing group"* : literature review, proposal of a bi-level coordination model for energy sharing between aggregator of flexible users and wind power plant, single-level reduction with KKT conditions, development of stochastic bi-level MILP model in Gurobi environment, input data collection, paper writing and results elaboration.
- [P₃]In the journal paper *"Prosumers as active market participants: a systematic review of evolution of opportunities, models and challenges"* : literature review, proposal of schematic critical evolution of the final user from completely passive entity to active network user, input data collection, return on investment analysis of low-carbon technologies, visualization and graphics creation, paper writing and results elaboration.
- [P₄]In the conference paper *"DSO and Aggregator Sharing Concept for Distributed Battery Storage System"* : literature review, proposal of joint storage use from the DSO and final users for local voltage control, SOCP AC OPF distribution network modelling in Gurobi environment, input data collection, paper writing and live presentation.
- [P₅]In the conference paper *"Bi-level modelling approach to coordinated operation of wind power plant and PV-storage energy community"* : literature review, envisioned the innovative type of balancing group for uncertainties mitigation and imbalance penalties reduction, development of stochastic bi-level MILP model in Gurobi environment, paper writing and live presentation.
- [P₆]In the conference paper *"Optimal sizing of battery storage units integrated into fast charging EV stations"* : definition of case studies, part in writing the paper.
- [P₇]In the conference paper *"Model zajedničkog sudjelovanja aktivnih kupaca i obnovljivih izvora na tržištu električnom energijom"* : literature review, proposal of coordinated market participation of renewable energy sources and flexible prosumers, model simulation in Gurobi environment, definition of case study, paper writing and live presentation.
- [P₈]In the conference paper *"The Value of Prosumers' Flexibility under Different Electricity Market Conditions: Case Studies of Denmark and Croatia"* : literature review, model of flexible prosumer in Gurobi environment, critical comparison between pricing options different countries, input data collection, paper writing and live presentation.
- [P₉]In the conference paper *"Podjela troškova električne energije između članova fleksibilne energetske zajednice"* : literature review, mathematical model of internal price calculation in energy community, case study definition, paper writing and live presentation.
- [P₁₀]In the conference paper *"Decentralized Platform for Investments and Operation of Energy Communities"* : proposal of upgraded energy community model, optimization of community trading formulated as MILP model and solved in Gurobi environment, return on investment analysis of low-carbon technologies, part in writing the paper.
- [P₁₁]In the conference paper *"Open source tools for integrated operation and planning of*

flexible buildings and distribution network" : conceptualization, literature review, paper writing, results elaboration and live presentation.

[P₁₂]In the conference paper "*A review of practical aspects of existing TSO- DSO coordination mechanisms in Europe and proposal of an innovative hybrid model in ATTEST project*" : literature review, critical comparison between different TSO-DSO coordination mechanisms, visualization and graphics creation, paper writing, results elaboration and live presentation

[P₁₃]In the conference paper "*Collaboration Models Between Distribution System Operators and Flexible Prosumers*" : literature review, proposal of innovative price-based demand response program considering electricity based component and DSO requirement for the service provision, flexibility modelling under different pricing options in Gurobi environment, paper writing, results elaboration and live presentation.

Chapter 7

Conclusions and Future Work

The main focus of the thesis is put on the final customer's role in the transition towards low-carbon power system together with innovative pricing mechanisms which stimulate their flexible behaviour. Chapter 7.1 brings the main conclusions, while Chapter 7.2 gives an overview of the author's possible future research directions.

7.1 The Main Conclusions of the Thesis

To reduce the harmful effects of greenhouse gas emissions on climate and global temperature increase, electricity production from fossil fuel power plants should be replaced with cleaner RES. The transition towards the low-carbon power system requires significant changes in both planning and operation stages due to the increased uncertainty in the power system from intermittent and variable RES production. To maintain a secure and reliable system operation and ensure efficient energy supply, additional flexibility is necessary. In the traditional power system, production followed the demand requirements in every time step. However, in the low-carbon environment, the demand is required to follow the production from RES in order to maintain supply-demand balance. It is important to find the proper incentives for demand remuneration for providing an adequate level of flexibility. The thesis focuses on the final customer who is put in the center of the clean energy transition. The critical review describes the transformation of final customer behavior from passive consumption under non-competitive flat prices, through the introduction of price-based and incentive-based demand response programs which stimulate their flexible behaviour according to the power system needs, different forms of aggregation and p2p trading, and finally providing ancillary services to both DSO and TSO. Models developed in the thesis investigate the return on investment in low-carbon technologies from the prosumer's side in the realistic pricing environment in several European countries. Moreover, different pricing options are compared to investigate the benefits of RT dynamic prices with low-carbon technology penetration.

The following part of the thesis moves from the individual final user's behaviour to the different forms of aggregation. As the subsidies for PV installation and feed-in-tariff have gradually been abandoned, electricity suppliers started to offer to prosumers higher buying prices compared to the selling prices to hedge against the risk of uncertainties and imbalance penalties. This price gap opened the door for p2p trading between final customers. The thesis investigates the financial benefits of p2p energy trading in the energy community from the final customer's side. The models for cost allocation between community members proposed in the thesis are based on DA energy market prices and flexibility incentives from the community manager which encourage the energy community members to follow the predefined DA schedule in order to contribute to the overall system balance. The thesis defines optimal cost-sharing models for all types of final customers which ensure lower electricity cost to all community members compared to the traditional contract with the supplier.

The last part of the thesis is focused on reducing imbalance costs due to the stochastic nature of renewable energy sources through joint market participation of wind power plant and the aggregator of flexible prosumers. The model develops a pricing mechanism that stimulates the flexible behaviour of final users in order to mitigate the imperfect DA predictions from both the aggregator and wind power plant. Electricity prices set by the aggregator stimulate the battery's charging and discharging process in order to reduce the deviations from the decision made in the DA market, but also to minimize the final user's electricity cost.

7.2 Future Work

The proposed models of flexible final customers have been developed from the energy market perspective considering the financial benefits of all parties involved in the transactions. Future research will focus on the implementation of proposed models in the distribution network environment considering realistic test cases of final users in size and characteristics. Moreover, the developed models will be upgraded taking into account providing flexibility services to solve problems in the local distribution networks, unallowed voltage deviations, and congestion, and also to the TSO at the TSO-DSO interconnection point. The research gap for the potential further analysis is the methodology for a price calculation for the flexibility service provision based on investments in low carbon technologies, network upgrade, and energy prices predictions.

Bibliography

- [1]IRENA, “Power system flexibility for the energy transition, part 1: Overview for policy makers”, Available: https://www.irena.org/-/media/Files/IRENA/Agency/Publication/2018/Nov/IRENA_Power_system_flexibility_1_2018.pdf (2018.).
- [2]European Commission, “Pv status report 2019”, Available: https://ec.europa.eu/jrc/sites/default/files/kjna29938enn_1.pdf (2019.).
- [3]Ziegleraand, M. S., Trancik, J. E., “ Re-examining rates of lithium-ion battery technology improvement and cost decline”, *Energy & Environmental Science*, Vol. 14, 2021.
- [4]Nordpool, Available: <https://www.nordpoolgroup.com/>
- [5]MIBEL, Available: https://www.mibel.com/en/home_en/
- [6]Epexspot, Available: <https://www.epexspot.com/en>
- [7]HUPX, Available: <https://hupx.hu/en/>
- [8]CROPEX, Available: <https://www.cropex.hr/en/>
- [9]Silva, P., Cerqueira, P., “Assessing the determinants of household electricity prices in the EU: a system-GMM panel data approach”, *Renewable and Sustainable Energy Reviews*, Vol. 73, No. 12, February 2017, pp. 1131-1137.
- [10]Europe beyond coal, Available: <https://beyond-coal.eu>
- [11]IRENA (2021), “Renewable Energy Statistics 2021”, The International Renewable Energy Agency, Abu Dhabi, Available: <https://irena.org/publications/2020/Mar/Renewable-Capacity-Statistics-2020> (2020.).
- [12]European Commission, “Directive (EU) 2019/944 of the European Parliament and of the Council 5 June 2019 on common rules for the internal market for electricity and amending Directive 2012/27/EU”, Available: <https://eur-lex.europa.eu/legal-content/EN/TXT/PDF/?uri=CELEX:32019L0944> (2019.).

- [13]Muqet, H. A. U., Ahmad, A., “Optimal Scheduling for Campus Prosumer Microgrid Considering Price Based Demand Response”, IEEE Access, 2020.
- [14]Koskela, J., Rautiainen, A., Järventausta, P., “Using electrical energy storage in residential buildings – sizing of battery and photovoltaic panels based on electricity cost optimization”, Applied Energy, 2019.
- [15]Wang, Y., Lin, H., Liu, Y., Sun, Q., Wennersten, R., “Management of household electricity consumption under price-based demand response scheme”, Journal of Cleaner Production, 2018.
- [16]Pallonetto, F., De Rosa, M., Milano, F., Finn, D. P., “Demand response algorithms for smart-grid ready residential buildings using machine learning models”, Applied Energy, 2019.
- [17]Guo, P., Lam, J. C., Li, V. O., “Drivers of domestic electricity users’ price responsiveness: A novel machine learning approach”, Applied Energy, 2019.
- [18]Zhou, B., Yang, R., Li, C., Cao, Y., Wang, Q., Liu, J., “Multiobjective Model of Time-of-Use and Stepwise Power Tariff for Residential Consumers in Regulated Power Markets”, IEEE Systems Journal, 2018.
- [19]Zhou, L., Zhang, Y., Li, K., Xie, X., “Optimal Sizing of PV System and BESS for Smart Household under Stepwise Power Tariff”, in 2018 International Conference on Power System Technology (POWERCON), Guangzhou, China, January 2019, pp. 1314-1319.
- [20]Golmohamadi, H., Keypour, R., Bak-Jensen, B., Radhakrishna Pillai, J., “Optimization of household energy consumption towards day-ahead retail electricity price in home energy management systems”, Sustainable Cities and Society, 2019.
- [21]Nan, S., Zhou, M., Li, G., “Optimal residential community demand response scheduling in smart grid”, Applied Energy, 2018.
- [22]Haider, H., See, O. H., Elmenreich, W., “A review of residential demand response of smart grid”, Renewable and Sustainable Energy Reviews, 2016.
- [23]Zheng, W., Wu, W., Zhang, B., Lin, C., “Distributed optimal residential dr considering operational constraints of unbalanced distribution networks”, IET Generation, Transmission and Distribution, 2018.
- [24]Aalami, H., Moghaddam, M. P., Yousefi, G., “Demand response modeling considering interruptible/curtailable loads and capacity market programs”, Applied Energy, 2010.

- [25]Moghaddam, M. P., Abdollahi, A., Rashidinejad, M., “Flexible demand response programs modeling in competitive electricity markets”, *Applied Energy*, 2011.
- [26]Jalali, A., Sepasian, M. S., Sheikh-El-Eslami, M. K., “Undisruptive load curtailment scheme to ensure voltage stability margin.”, *IET Generation, Transmission and Distribution*, 2019.
- [27]Ziqing, J., Qian, A., Ran, H., “Integrated dr mechanism for industrial energy system based on multi-energy interaction”, *IEEE Access*, 2019.
- [28]Li, W.-T., Gubba, S. R., Tushar, W., Yuen, C., Hassan, N. U., Poor, H. V., Wood, K. L., Wen, C.-K., “Data driven electricity management for residential air conditioning systems: An experimental approach”, *IEEE Transactions on Emerging Topics in Computing*, 2019.
- [29]Xing, H., Cheng, H., Zhang, L., “Demand response and wind farm integrated economic dispatch in power system”, in *TENCON 2015 - 2015 IEEE Region 10 Conference*, Macao, China, November 2015, pp. 1-5.
- [30]Good, N., “Using behavioural economic theory in modelling of demand response”, *Applied Energy*, 2019.
- [31]Chen, S., Chen, Q., Xu, Y., “Strategic bidding and compensation mechanism for a load aggregator with direct thermostat control capabilities”, *IEEE Transactions on Smart Grid*, 2018.
- [32]Zhu, L., Zhou, X., Zhang, X.-P., Yan, Z., Guo, S., Tang, L., “Integrated resources planning in microgrids considering interruptible loads and shiftable loads”, *Journal of Modern Power Systems and Clean Energy*, 2018.
- [33]Yan, N., Zhang, B., Li, W., Ma, S., “Hybrid energy storage capacity allocation method for active distribution network considering demand side response”, *IEEE Transactions on Applied Superconductivity*, 2019.
- [34]Althaher, S., Mancarella, P., Mutale, J., “Automated demand response from home energy management system under dynamic pricing and power and comfort constraints”, *IEEE Transactions on Smart Grid*, 2015.
- [35]Bhana, R., Overbye, T. J., “The commitment of interruptible load to ensure adequate system primary frequency response”, *IEEE Transactions on Power Systems*, 2016.

- [36]Zhao, J., Wan, C., Xu, Z., Wong, K. P., “Spinning reserve requirement optimization considering integration of plug-in electric vehicles”, *IEEE Transactions on Smart Grid*, 2017.
- [37]Kushwaha, P., Prakash, V., Bhakar, R., Yaragatti, U. R., “Pfr constrained energy storage and interruptible load scheduling under high re penetration”, *IET Generation, Transmission and Distribution*, 2020.
- [38]Hayes, B., Chapter 9 - Distribution Generation Optimization and Energy Management, Gharehpetian, G., Mohammad Mousavi Agah, S., (ur.). Butterworth-Heinemann, 2017.
- [39]Alam, M. R., St-Hilaire, M., Kunz, T., “Energy Management Strategy Considering Multi-time-scale Operational Modes of Batteries for the Grid-connected Microgrids Community”, *CSEE JOURNAL OF POWER AND ENERGY SYSTEMS*, Vol. 6, 2020.
- [40]Imani, M. H., Ghadi, M. J., Ghavidel, S., Li, L., “Demand response modeling in micro-grid operation: a review and application for incentive-based and time-based programs”, *Renewable and Sustainable Energy Reviews*, 2018.
- [41]Rabiee, A., Sadeghi, M., Aghaeic, J., Heidari, A., “Optimal operation of microgrids through simultaneous scheduling of electrical vehicles and responsive loads considering wind and pv units uncertainties”, *Renewable and Sustainable Energy Reviews*, 2016.
- [42]Li, J., Liu, Y., Wu, L., “Optimal operation for community-based multi-party microgrid in grid-connected and islanded modes”, *IEEE Transactions on Smart Grid*, 2018.
- [43]Shafiuzzaman, M., Khadem, K., Basu, M., Conlon, M. F., “Upqc for power quality improvement in dg integrated smart grid network - a review”, *International Journal of Emerging Electric Power Systems*, 2012.
- [44]Fan, B., Guo, S., Peng, J., Yang, Q., Liu, W., Liu, L., “A consensus-based algorithm for power sharing and voltage regulation in dc microgrids”, *IEEE Transactions on Industrial Informatics*, 2020.
- [45]Ampolu, M., Swarup, S., “Stochastic optimal bidding strategy for energy and ancillary services in microgrid”, *IEEE Transactions on Industry Applications*, 2021.
- [46]Lidula, N., Rajapakse, A., “Microgrids research: A review of experimental microgrids and test systems”, *Renewable and Sustainable Energy Reviews*, 2011.
- [47]Hossain, E., Kabalci, E., Bayindir, R., Perez, R., “Microgrid testbeds around the world: State of art”, *Energy Conversion and Management*, 2014.

- [48]Smart Grid Lab, Available: <https://sglab.fer.hr/sglab/laboratory>
- [49]European Commission, “Directive (EU) 2018/2001 of the European Parliament and of the Council of 11 December 2018 on the promotion of the use of energy from renewable sources”, Available: <https://eur-lex.europa.eu/legal-content/EN/TXT/PDF/?uri=CELEX:32018L2001&qid=1626270736861&from=EN> (2018.).
- [50]Regulatory Aspects of SelfConsumption and Energy Communities, Available: <https://www.ceer.eu/documents/104400/-/-/8ee38e61-a802-bd6f-db27-4fb61aa6eb6a>
- [51]Alam, M. R., St-Hilaire, M., Kunz, T., “An optimal P2P energy trading model for smart homes in the smart grid”, *Energy Efficiency*, Vol. 10, 2017.
- [52]Liu, N., Yu, X., Wang, C., Li, C., Ma, L., Lei, J., “Energy-Sharing Model With Price-Based Demand Response for Microgrids of Peer-to-Peer Prosumers”, *IEEE TRANSACTIONS ON POWER SYSTEMS*, Vol. 32, 2017.
- [53]Lütha, A., Zepter, J. M., del Granadoa, P. C., R.Egginga, “Local electricity market designs for peer-to-peer trading: The role of battery flexibility”, *Applied Energy*, Vol. 229, 2018.
- [54]FIROOZI, H., KHAJEH, H., LAAKSONEN, H., “Optimized Operation of Local Energy Community Providing Frequency Restoration Reserve”, *IEEE ACCESS*, 2020.
- [55]OH, E., SUNG-YONG, “Peer-to-Peer Energy Transaction Mechanisms Considering Fairness in Smart Energy Communities”, *IEEE ACCESS*, 2020.
- [56]Oprea, S. V., Bara, A., Andreescu, A. I., “Two Novel Blockchain-Based Market Settlement Mechanisms Embedded into Smart Contracts for Securely Trading Renewable Energy”, *IEEE Access*, Vol. 8, 2020.
- [57]Feng, C., Wen, F., You, S., Li, Z., Shahnia, F., Shahidehpour, M., “Coalitional Game-Based Transactive Energy Management in Local Energy Communities”, *IEEE Transactions on Power Systems*, Vol. 35, 2020.
- [58]Crespo-Vazquez, J. L., Alskaf, T., Gonzalez-Rueda, A. M., Gibescu, M., “A Community-Based Energy Market Design Using Decentralized Decision-Making under Uncertainty”, *IEEE Transactions on Smart Grid*, Vol. 12, 2021.
- [59]Cui, S., Member, G. S., Wang, Y.-w., Member, S., “Community Energy Cooperation With the Presence of Cheating Behaviors”, *IEEE Transactions on Smart Grid*, Vol. 12, 2021.

- [60]Mediwaththe, C. P., Stephens, E. R., Smith, D. B., Mahanti, A., “Competitive Energy Trading Framework for Demand-Side Management in Neighborhood Area Networks”, *IEEE Transactions on Smart Grid*, Vol. 9, 2018.
- [61]Lilla, S., Orozco, C., Borghetti, A., Napolitano, F., Tossani, F., “Day-Ahead Scheduling of a Local Energy Community: An Alternating Direction Method of Multipliers Approach”, *IEEE Transactions on Power Systems*, Vol. 35, 2020.
- [62]Mediwaththe, C. P., Blackhall, L., “Network-Aware Demand-Side Management Framework with A Community Energy Storage System Considering Voltage Constraints”, *IEEE Transactions on Power Systems*, Vol. 36, 2021.
- [63]Cui, S., Wang, Y. W., Li, C., Xiao, J. W., “Prosumer community: A risk aversion energy sharing model”, *IEEE Transactions on Sustainable Energy*, Vol. 11, 2020.
- [64]Paudel, A., Chaudhari, K., Long, C., Gooi, H. B., “Peer-to-peer energy trading in a prosumer-based community microgrid: A game-theoretic model”, *IEEE Transactions on Industrial Electronics*, Vol. 66, 2019.
- [65]Liu, Y., Hu, S., Member, S., “Renewable Energy Pricing Driven Scheduling in Distributed Smart Community Systems”, *Ieee Transactions on Parallel and Distributed Systems*, Vol. 28, 2017.
- [66]Pourakbari-Kasmaei, M., Asensio, M., Lehtonen, M., Contreras, J., “Trilateral Planning Model for Integrated Community Energy Systems and PV-Based Prosumers-A Bilevel Stochastic Programming Approach”, *IEEE Transactions on Power Systems*, Vol. 35, 2020.
- [67]“Enenergy communités europe”, Available: <https://enercommunities.eu/> September 2020.
- [68]“Energinet”, Available: <https://en.energinet.dk/Electricity>
- [69]Nan, S., Zhou, M., Li, G., “Optimal residential community demand response scheduling in smart grid”, *Applied Energy*, Vol. 210, 2018.
- [70]Ottesen, S. Ø., Tomasgard, A., Fleten, S. E., “Prosumer bidding and scheduling in electricity markets”, *Energy*, Vol. 94, 2016.
- [71]Baringo, L., Sánchez Amaro, R., “A stochastic robust optimization approach for the bidding strategy of an electric vehicle aggregator”, *Electric Power Systems Research*, Vol. 146, 2017.

- [72]Iria, J., Soares, F., “A cluster-based optimization approach to support the participation of an aggregator of a larger number of prosumers in the day-ahead energy market”, *Electric Power Systems Research*, Vol. 168, 2019.
- [73]Ayón, X., Gruber, J., Hayes, B., Usaola, J., Prodanović, M., “An optimal day-ahead load scheduling approach based on the flexibility of aggregate demands”, *Applied Energy*, Vol. 198, 2017.
- [74]Correa-Florez, C. A., Michiorri, A., Kariniotakis, G., “Robust optimization for day-ahead market participation of smart-home aggregators”, *Applied Energy*, Vol. 229, 2018.
- [75]Ross, S., Mathieu, J., “Strategies for network-safe load control with a third-party aggregator and a distribution operator”, *IEEE Transactions on Power Systems*, Vol. 36, 2021.
- [76]Posma, J., Lampropoulos, I., Schram, W., van Sark, W., “Provision of Ancillary Services from an Aggregated Portfolio of Residential Heat Pumps on the Dutch Frequency Containment Reserve Market”, *Applied Sciences*, Vol. 9, 2019.
- [77]Fleer, J., Zurmühlen, S., Meyer, J., Badeda, J., Stenzel, P., Hake, J.-F., Sauer, D. U., “Techno-economic evaluation of battery energy storage systems on the primary control reserve market under consideration of price trends and bidding strategies”, *Journal of Energy Storage*, Vol. 17, 2018.
- [78]Hoogvliet, T., Litjens, G., van Sark, W., “Provision of regulating- and reserve power by electric vehicle owners in the Dutch market”, *Applied Energy*, Vol. 190, 2017.
- [79]Pavić, I., Capuder, T., Kuzle, I., “A Comprehensive Approach for Maximizing Flexibility Benefits of Electric Vehicles”, *IEEE Systems Journal*, Vol. 12, 2018.
- [80]Zhao, H., Wu, Q., Huang, S., Zhang, H., Liu, Y., Xue, Y., “Hierarchical Control of Thermostatically Controlled Loads for Primary Frequency Support”, *IEEE Transactions on Smart Grid*, Vol. 9, 2018.
- [81]Vahedipour-Dahraie, M., Rashidizadeh-Kermani, H., Shafie-Khah, M., Siano, P., “Peer-to-Peer Energy Trading Between Wind Power Producer and Demand Response Aggregators for Scheduling Joint Energy and Reserve”, *IEEE Systems Journal*, Vol. 15, 2021.
- [82]Fotouhi Ghazvini, M. A., Lipari, G., Pau, M., Ponci, F., Monti, A., Soares, J., Castro, R., Vale, Z., “Congestion management in active distribution networks through demand response implementation”, *Sustainable Energy, Grids and Networks*, Vol. 17, 2019.
- [83]Olivella-Rosell, P., Lloret-Gallego, P., Munné-Collado, I., Villafafila-Robles, R., Sumper, A., Ottessen, S. O., Rajasekharan, J., Bremdal, B. A., “Local flexibility market design

- for aggregators providing multiple flexibility services at distribution network level”, *Energies*, Vol. 11, 2018.
- [84]Amamra, S.-A., Marco, J., “Vehicle-to-grid aggregator to support power grid and reduce electric vehicle charging cost”, *IEEE Access*, Vol. 7, 2019.
- [85]Liao, H., Milanovi ć, J. V., “Flexibility exchange strategy to facilitate congestion and voltage profile management in power networks”, *IEEE Transactions on Smart Grid*, Vol. 10, 2019.
- [86]Asrari, A., Ansari, M., Khazaei, J., Fajri, P., “A market framework for decentralized congestion management in smart distribution grids considering collaboration among electric vehicle aggregators”, *IEEE Transactions on Smart Grid*, Vol. 11, 2020.
- [87]Hanif, S., Gooi, H. B., Massier, T., Hamacher, T., Reindl, T., “Distributed congestion management of distribution grids under robust flexible buildings operations”, *IEEE Transactions on Power Systems*, Vol. 32, 2017.
- [88]Huang, S., Wu, Q., Shahidehpour, M., liu, Z., “Dynamic power tariff for congestion management in distribution networks”, *IEEE Transactions on Smart Grid*, Vol. 10, 2019.
- [89]“Kiwi power”, Available: <https://www.kiwipowered.com/>
- [90]“Next kraftwerke”, Available: <https://www.next-kraftwerke.de/>
- [91]“Energy pool”, Available: <https://www.energy-pool.eu/en/>
- [92]“Flexible power”, Available: <https://www.flexiblepower.co.uk/>
- [93]“Nodes”, Available: <https://nodesmarket.com/>
- [94]Boyd, S., Vandenberghe, L., (ur.), *Convex optimization*. New York, USA: Cambridge University Press, 2004.
- [95]Vanderbei, R. J., (ur.), *Linear Programming*. Springer, Boston, MA, 2014.
- [96]Floudas, C. A., (ur.), *Nonlinear and Mixed-Integer Optimization: Fundamentals and Applications*. Oxford University Press, 1995.
- [97]Pardalos, P., (ur.), *Nonconvex Optimization and Its Applications*. Springer.
- [98]Martins, E., Pascoal, M., Rasteiro, D., Dos Santos, J. L. E., “The Optimal Path Problem”, *Journal of Operational Research Society*, 1999.

- [99]Morrison, D. R., Jacobson, S. H., Sauppe, J. J., Sewell, E. C., “Branch-and-bound algorithms: A survey of recent advances in searching, branching, and pruning”, *Discrete Optimization*, 2016.
- [100]Savelsbergh, M. W. P., *Branch and price: Integer programming with column generation*. Springer US, 2001.
- [101]Gomes, C. P., “Randomized backtrack search: Extending the reach of complete search methods”, *Operations Research/ Computer Science Interfaces Series*, 2004.
- [102]O.Naud, *Support to decision-making*. Elsevier Inc., 2020.
- [103]Caccetta, L., Hill, S. P., “Branch and cut methods for network optimization”, *Mathematical Computational Modelling*, 2016.
- [104]Paschos, V. T., (ur.), *Concepts of Combinatorial Optimization*. John Wiley & Sons, 2014.
- [105]R.Apt, K., *Principles of Constraint Programming*. Cambridge University Press, 2003.
- [106]Haghray, A. A., Mohammadi-ivatloo, B., Mohammadi, Seyedmonir, S., “Real coded genetic algorithm approach with random transfer vectors-based mutation for short-term hydro-thermal scheduling”, *IET Generation, Transmission and Distribution*, 2015.
- [107]AlRashidi, M. R., El-Hawary, M. E., “A survey of particle swarm optimization applications in electric power systems”, *IEEE Transactions on Evolutionary Computation*, 2009.
- [108]Civicioglu, P., Besdok, E., “A conceptual comparison of the cuckoo-search, particle swarm optimization, differential evolution and artificial bee colony algorithms”, *Artificial Intelligence Review*, 2013.
- [109]Sinha, A., Malo, P., Deb, K., “A Review on Bilevel Optimization: From Classical to Evolutionary Approaches and Applications”, *IEEE Transactions on Evolutionary Computation*, Vol. 22, No. 2, 2018, pp. 276-295.
- [110]Fortuny-Amat, J., McCarl, B., “Representation and Economic Interpretation of a Two-Level Programming Problem”, *Journal of Operational Research Society*, Vol. 32, 1981.
- [111]Conejo, A. J., Carrión, M., Morales, J. M., (ur.), *Decision Making Under Uncertainty in Electricity Markets*. USA: Springer US, 2010.
- [112]Ser, J. D., (ur.), *Nature-inspired Methods for Stochastic, Robust and Dynamic Optimization*. London, United Kingdom: IntechOpen, 2018.

[113]Dritsas, I., (ur.), Chance Constrained Programming and Its Applications to Energy Management, Stochastic Optimization - Seeing the Optimal for the Uncertain. London, United Kingdom: IntechOpen, 2011.

[114]Online Optimization. New York, USA: Springer US, 2021.

Abbreviation

ADMM Alternating Direction Method of Multipliers

AS Ancillary Service

BES Battery energy storage

BG Balancing Group

BRP Balance Responsible Party

BSMN Bill Sharing Method Net

CEC Renewable Energy Community

CL Curtailable load

CM Community Manager

CPP Critical Peak Pricing

DA Day-Ahead

DC Direct current

DE Differential Evolution

DER Distributed Energy Resources

DG Distributed Generation

DLCDirect-load control

DR Demand Response

DSO Distribution System Operator

EV Electric Vehicle

EU European Union

FSP Flexibility Service Provider

GAGenetic Algorithm

HEM Household Energy Management System

ICT Information and Communications Technology

KKT Karush-Kuhn-Tucker

LV Low-voltage

LPLinear Programming

MILP Mixed Integer Linear Programming

MMRN Mid-Market Rate Net

p2p peer-to-peer

PCS Primary control Reserve

PSO Particle Swarm Optimization

PTR Peak-time Rebates

PV Photovoltaic

REC Renewable Energy Community

RES Renewable Energy Sources

RT Real-Time

SDRN Supply Demand Ratio Net

SWPT Step-wise power tariff

TCL Thermostatically Controlled Loads

ToU Time-of-Use

TSO Transmission System Operator

V2G Vehicle-to-grid

VPP Virtual Power Plant

WPP Wind Power Plant

Publications

There are in total 3 journal papers and 10 conference papers (9 presented and 1 under review) under this thesis. All journal papers are attached bellow. However, only 5 papers presented on the international conferences are attached due to the brevity of the thesis.

Journal Papers

- [P₁]M. Gržanić, J. M. Morales, S. Pineda, and T. Capuder, "Electricity cost-sharing in energy communities under dynamic pricing and uncertainty, " *IEEE ACCESS*, pp. 1-18, 2021, ISSN: 2169-3536, DOI: 10.1109/ACCESS.2021.3059476
- [P₂]M. Gržanić and T. Capuder, "Coordinated scheduling of renewable energy balancing group," *International Journal of Electrical Power & Energy Systems*, pp. 1-10, February 2021, ISSN: 0142-0615, DOI: 10.1016/j.ijepes.2020.106555
- [P₃]M. Gržanić, T. Capuder, N. Zhang, W. Huang, "Prosumers as active market participants: A systematic review of evolution of opportunities, models and challenges," *Renewable and Sustainable Energy Reviews*, pp. 1-31, November 2021, ISSN: 1364-0321, DOI: 10.1016/j.rser.2021.111859

Published and Presented

- [P₄]M. Gržanić, T. Capuder, and S. Krajcar, "DSO and Aggregator Sharing Concept for Distributed Battery Storage System," in *2018 IEEE International Conference on Environment and Electrical Engineering and 2018 IEEE Industrial and Commercial Power Systems Europe IEEEIC / I&CPS Europe*, 10.1109/IEEEIC.2018.8493680
- [P₅]M. Gržanić and T. Capuder, "Bi-level modelling approach to coordinated operation of wind power plant and PV-storage energy community," in *2018 IEEE International Energy Conference ENERGYCON*, 10.1109/ENERGYCON.2018.8398844
- [P₆]V. Salapić, M. Gržanić, and T. Capuder, "Optimal sizing of battery storage units integrated into fast charging EV stations," in *2018 IEEE International Energy Conference ENERGYCON*, 10.1109/ENERGYCON.2018.8398789
- [P₇]M. Gržanić and T. Capuder, "The Value of Prosumers' Flexibility under Different Electricity Market Conditions: Case Studies of Denmark and Croatia," in *2019 IEEE PES GTD Grand International Conference and Exposition Asia GTD Asia*, Bangkok, Thailand, 10.1109/GTDAsia.2019.8715888

[P₈]M. Gržanić, T. Capuder, M. Bolfek, and F. Capitanescu, "A review of practical aspects of existing TSO- DSO coordination mechanisms in Europe and proposal of an innovative hybrid model in ATTEST project," in *EEEIC International Conference on Environment and Electrical Engineering 2021*, Bari, Italy

Received February 2, 2021, accepted February 10, 2021, date of publication February 15, 2021, date of current version February 25, 2021.

Digital Object Identifier 10.1109/ACCESS.2021.3059476

Electricity Cost-Sharing in Energy Communities Under Dynamic Pricing and Uncertainty

MIRNA GRŽANIĆ¹, (Student Member, IEEE), JUAN M. MORALES², (Senior Member, IEEE), SALVADOR PINEDA², (Member, IEEE), AND TOMISLAV CAPUDER¹, (Member, IEEE)

¹Faculty of Electrical Engineering and Computing, University of Zagreb, 10 000 Zagreb, Croatia

²Faculty of Industrial Engineering, University of Malaga, 29071 Málaga, Spain

Corresponding author: Mirna Gržanić (mirna.grzanic@fer.hr)

This work was supported in part by the Croatian Science Foundation (HRZZ) and Croatian Distribution System Operator (HEP ODS) HRZZ under the project IMAGINE — Innovative Modelling and Laboratory Tested Solutions for Next Generation of Distribution Networks, in part by the Croatian Science Foundation (HRZZ) under the project Active NeIghborhoods energy Markets pArTicipatIOn—ANIMATION (IP-2019-04-09164), in part by the Spanish Ministry of Economy, Industry and Competitiveness under Project ENE2017-83775-P, and in part by the European Research Council (ERC) under the European Union (EU) Horizon 2020 Research and Innovation Programme under Grant 755705.

ABSTRACT Most of the prosumers nowadays are constrained to trade only with the supplier under a flat tariff or dynamic time-of-use price signals. This paper models and discusses the cost-saving benefits of flexible prosumers as members of energy communities who can exchange electricity among peers and on the wholesale markets through a community manager. Authors propose a novel centralized post-process sharing method by introducing a two-stage mechanism which, unlike the existing methods, guarantees benefits for prosumers joining the energy community. The first stage assesses internal price calculation in three different methods: Bill Sharing Method Net (BSMN), Mid-Market Rate Net (MMRN), and Supply-Demand Ratio Net (SDRN). In their original form, prices are calculated in a single stage and the comprehensive analyses in the paper show that some members face increased cost. To solve this issue, the paper improves the methods by introducing the second stage in which the compensation methodology is defined for the distribution of savings which ensures that all community members gain benefits. Results investigate the value of inner technical flexibility of the prosumer (flexible preferences of the final consumer can reduce the cost from 3% up to 20 %). Moreover, incentives/penalties encourage the utilization of a flexible behavior to adjust the real-time consumption of prosumers' appliances to a predefined day-ahead schedule. This type of pricing results in a lower amount of benefits sharing in the community (the reduction of 18-47% in MMRN and 49-114% in SDRN compared to existing pricing) which makes this incentives/penalties pricing more preferable. The paper concludes that prosumers with an excess PV production would not benefit from the internal energy exchange in the community under BSMN due to free energy exchange between members.

INDEX TERMS Cost-sharing, day-ahead market, demand response, energy community, peer-to-peer trading.

I. NOMENCLATURE

Stochastic and non-stochastic parameters are presented as **bold** text, while variables are a regular type of text. Where augmented with the subscripts s and t , they refer to the values they take on in scenario s and time period t , while the subscript d stands for a household and ap for a different uninterruptible flexible appliance. If not stated differently, variables and parameters are positive.

The associate editor coordinating the review of this manuscript and approving it for publication was Xiaosong Hu¹.

Indices and Sets

$ap \in A$	Uninterruptible flexible appliances
$d \in D$	Households
$d \in D^+$	Community members with decreased cost in the first stage
$d \in D^-$	Community members with increased cost in the first stage
$t \in T$	Time steps
$s \in S$	Scenarios

Parameters

π_s	Probability of scenario s
---------	-----------------------------

$\lambda_t^{DAB/S}$	Day-ahead (DA) buying/selling price [DKK/kWh]
\underline{E}_d	Minimum state of energy of EV at the end of a charging cycle [kWh]
\bar{E}_d	The battery capacity of EV [kWh]
\bar{P}_d	Maximum charging power of EV [kW]
P^{uniap}	Power of uninterruptible appliance [kW]
L^{ap}	Cycle length of uninterruptible appliance [h]
$H_d^{a/l}$	The hour when a car arrives/leaves at home [h]
Δt	Time interval [1h]
$\lambda_t^{DOWN/UP}$	Down/up incentive price [DKK/kWh]
$\lambda^{BALB/S}$	Balancing cost for bought and sold energy [DKK/kWh]
λ^{NET}	Network charges [DKK/kWh]

Stochastic parameters

$P_{d,s,t}^{ms}$	Must-serve load [kW]
$PV_{d,s,t}$	PV production [kW]

Variables

$cost_{s,t}^{pen}$	penalization cost [DKK]
C_d^{ind}	Individual cost under supplier [DKK]
C_d^{comm}	Cost of a community member in the first stage under cost-sharing mechanism m [DKK]
C_d^{new+}	Cost of a community member in the second stage who was better off in the community in the first stage [DKK]
C_d^{new-}	Cost of a community member in the second stage who was worst off in the community in the first stage [DKK]
C^+	Sum of the cost reduction of community members compared to individual trading with supplier [DKK]
C^-	Sum of the cost increase of community members compared to individual trading with supplier [DKK]
min bound	The minimum value of benefits for sharing among community members
$P_{d,s,t}^{HD}$	Power imported (positive) /exported (negative) from/to supplier by household [kW]
$P_{s,t}^{GRID}$	Power imported (positive) /exported (negative) by the energy community [kW]
$P_{d,s,t}^{HDB/S}$	Imported/exported power of each household [kW]
$P_{s,t}^{UP/DOWN}$	The community's up/down regulation [kW]
$P_{d,s,t}^{HDB/S}$	Buying/selling power of household [kW]
$P_t^{DAB/S}$	DA community's contracted buying/selling power [kW]
$P_{d,s,t}^{net}$	Net-load (negative if PV production excesses load) [kW]
$P_{d,s,t}^{uniap}$	Consumption of uninterruptible appliance [kW]

$P_{d,s,t}^{EV}$	EV charging power [kW]
$P_{d,s,t}^{th}$	Thermal load [kW]
$P_{d,s,t}^{ch/dis}$	Battery charging/discharging [kW]
$P_{s,t}^{netpos/neg}$	Sum of positive/negative net-load in the community [kW]
$\lambda_{s,t}^{mB/S}$	Internal buying/selling price under cost-sharing mechanism m
$\lambda_{s,t}$	Compensation rate under SDRN [DKK/kWh]
$\lambda_{s,t}^{uniap}$	The average cost of energy [DKK/kWh]
$SDR_{s,t}$	Supply-demand ratio
Δ_d	Difference between individual cost and community member cost in the first stage

Binary variables

$x_{d,s,t}^{def}$	1 if EV is being charged and 0 otherwise
$x_{d,s,t}^{uniap}$	1 if the uninterruptible load starts the cycle and 0 otherwise

II. INTRODUCTION

A. MOTIVATION

The latest package of measures in the European Union (EU) for a clean energy transition, ‘Clean Energy for all Europeans’, puts the end-user into the focus by requiring, among other things, integration of more renewable energy sources (RES) and the market empowerment of final consumers [1]. To achieve this, new models and tools for end-consumers are needed, to give them the chance to find an alternative business model in order to reduce their electricity bill [2]. This is important since the survey conducted in [3] suggests there was a significant increase in the electricity retail price despite market liberalization. Moreover, many EU member states still regulate end-user electricity prices and have a single dominant supplier [4]. To enable the transition and utilize demand-side flexibility, it is crucial to have a retail-level competition and to offer market participation through innovative business models [5], [6]. In this context, energy communities have emerged as new entities providing the end-users novel platforms to invest into low carbon assets, but also as operational market entities with capabilities to exchange the surplus (deficit) of energy among their peers. Their main goal is to incentivize consumers to produce and consume energy locally, reducing the electricity cost and increasing the self-consumption of RES.

B. LITERATURE REVIEW

The community manager (CM) is a new market entity participating in the wholesale markets on behalf of its members, but it also coordinates the electricity trade and transactions within the community [7]. Different aspects and benefits of this concept have been researched, such as adjusting peak-hour load, reducing the grid losses [8] and congestions [9], and improving self-balancing to enable further integration of RES [10]. In general, the CM optimizes flexible assets of the community in order to achieve a better market position

by incentivizing its members to trade within the community or with the market whenever more convenient. The savings are shared among community members and the challenge is to find a cost-sharing method that fairly awards the peers depending on their contribution to the entire community's wellbeing. CM is an entity essentially different from a regular supplier and does not gain any profit. Indeed, the CM is, all in all, a platform for providing prosumers with multiple options for monetizing their flexibility, but also exposing them to risks of uncertainties traditionally hedged by the supplier. CM is in charge of scheduling the operation of the flexible appliances in the energy community in order to achieve the lowest electricity cost for the entire community. CM is a virtual entity managed and owned by the members of the community, meaning that, in the end, any profit made by the CM is divided among the community members.

A motivational psychology framework is proposed in [11] to describe the different motivational stages that encourage prosumers to join p2p energy trading. Their interaction is modelled as the canonical coalition game. The social cooperation between prosumers is modelled as a coalition formation game in [12] enabling prosumers to decide should they use battery storage in p2p trading. P2p trading can also be modelled through a bidding process or by way of a game-theory approach. The authors in [13], [14], and [15] present an auction-based p2p trading mechanism, where different bidding strategies for prosumers are analyzed. Several papers are based on game-theory (Stackelberg game, Nash bargaining, a non-cooperative game) to model the negotiation between prosumers or between prosumers and a central entity responsible for p2p trading. P2p energy trading based on a Stackelberg game in which the renewable and non-renewable producers lead, while prosumers and consumers follow is presented in [16] showing higher social welfare of consumers and prosumers compared to conventional p2p trading. The authors in [17] study the energy trading based on a Stackelberg game between prosumers who share energy storage. The energy sharing provider leads the game setting the internal trading prices, while the prosumers follow optimizing their energy profile. Two sharing modes are distinguished: directly sharing in which the energy sharing provider acts as an intermediary between prosumers with energy excess and deficit without the storage and buffered sharing in which the energy sharing provider uses a shared battery for matching the demand in different periods. The price competition on the upper level between the sellers is modelled as a noncooperative game, while the seller selection competition on the lower levels among buyers is modelled with an evolutionary approach. The interaction between upper and lower levels in p2p trading is based on a Stackelberg game [18] in which sellers are leaders and buyers are followers. A two-stage real-time (RT) energy sharing optimization model is presented in [19]. A cluster of buildings consisting of offices, industrial, and commercial buildings firstly minimizes the total energy cost and then shares the energy in a non-cooperative game with

transparent energy sharing profiles. The model deals with the uncertainty by adjusting the energy schedule traded with the retailer and keeping the predefined day-ahead (DA) energy exchange profile with other buildings. The bilevel objective model in [20] minimizes the cost and ensures fairness for all p2p members involved in energy trading based on the Nash bargaining solution taking into account network constraints and energy scheduling in both DA and RT markets. The privacy issue regarding p2p trading has been addressed in [15] and [21]. The distributed approach developed in [15] describes a method for local optimal energy scheduling and sharing that guarantees data confidentiality, while in [21] the prices provided from a p2p platform agent are calculated based on a multiclass energy management problem considering the wholesale energy price, the energy demand of each prosumer and the expected losses in an iterative process. A convex formulation of the model is proposed to reduce the computational burden and to implement it in RT. The model in this paper proposes a different approach in which the prices are not calculated in RT, i.e., they are calculated the day after energy delivery and therefore, the model does not require a fast optimization algorithm. Moreover, the paper precisely defines internal prices based on the amount of shared energy and both DA prices and incentives for flexibility. The authors in [22] compare cost-sharing-methods among community members, namely Bill Sharing Method (BSM), Mid-Market Rate (MMR), and Auction-based Pricing Strategy (APS) with flat buying and selling prices and without any demand response program. The work in [23] describes cost savings in an energy community with and without p2p trading. The results show that the community is always better off by performing p2p trading, however, the paper does not include a sharing mechanism that guarantees cost savings for all the community members and only focuses on the optimum for the entire community. The paper in [24] compares the outcome of BSM, MMR, and Supply Demand Ratio (SDR) cost-sharing mechanisms in an energy community using heuristic methods. To facilitate the convergence of the proposed algorithm, their model uses step-length control and includes a learning process. An innovative iterative p2p trading mechanism called ECO-Trade is described in [25], where the authors consider an energy community with different percentages of households equipped with PV and batteries to demonstrate that ECO-trade, which is based on a near-optimal algorithm, provides better solutions in terms of accuracy and computational time than that provided in [26]. The work in [27] proposes a SDR cost-sharing method within a p2p trading framework that takes into account consumers' preferences with respect to their desired level of participation. The model in [28] introduces a SDR-based profit-sharing scheme with a compensation rate that incentivizes all consumers to join the energy community by ensuring them lower electricity costs. The energy community is exposed to dynamic buying and selling prices, but there is no uncertainty related to the price or PV production and demand or discussion on the optimal cost-sharing method. As an upgrade of [28],

this paper precisely models demand flexibility, considers the stochastic nature of PV production and consumers' load, and investigates the value of flexibility incentives to adjust the RT operation schedule of household appliances to a predefined DA schedule. A multi-energy retailer (MER) aims to maximize its profit from selling electricity, gas, and heat demands to the multi-energy consumer [29]. MER participates in the electricity, gas, and heat market and operates tri-state compressed air energy storage (tri-CAES) and combined heat and power (CHP) technologies in order to satisfy the demand of final consumers. Final consumers are encouraged with incentive compensation to participate in load shifting when market prices are high resulting in reduced cost of MER. A multi-objective two-stage stochastic problem considering uncertainties related to electric and gas load and wind power plant (WPP) production is modeled in [30]. The benefits of employing demand response programs in electrical and gas networks are investigated, together with a reduction of CO₂ emissions resulting in no curtailment of WPP production and reduction of both gas and electrical network operational cost. Different models of community energy trading are compared in [31]. The first one does not consider any energy exchange between microgrids and is individually oriented. The second one proposes a collective benefit without considering individual interests. The third one focuses on a collective and a satisfactory level of individual interests, although the individual benefits of some microgrids are not accomplished in this model. The fourth one brings both collective and individual benefits with the same percentage of cost savings for each microgrid and presents the best solution of proposed models. A two-level optimization problem for cost minimization and peak shaving of neighboring energy hubs is presented in [32]. The lower level focuses on individual household (home energy hub HEH) energy supply, while the upper level forms the coalition giving HEHs and conventional buildings financial compensation to facilitate trading in the local market. Virtual energy hub supplies their heat and electricity demand from CHP, boilers, and local markets taking into account risk-constrained self-scheduling of battery and thermal storage to reduce the purchase cost of electricity and heat [33]. The results show almost 70% of cost reduction for electricity imported from local markets. The interaction of microgrids with 100% renewable power in the transactive energy markets is proposed in [34]. The case with local energy exchange brings 18.34 % cost reduction for each microgrid which highly motivates them for local energy sharing due to high energy prices for energy exchange with the main grid.

Based on the literature review shown in Table 1, the following research gaps have been identified:

- Relevant literature on cost-sharing methods recognizes three main categories: i) game-theory methods which are rather complex to deploy, such as [8], [16]–[18], ii) coalition games ([11], [12], [20]) and iii) post-event methods which guarantee model convergence (such as BSM, MMR, SDR [22], [28], [37]). Game-theory

cost-sharing methods are computationally demanding and this complexity increases exponentially with the number of peers. Coalition games are sometimes restricted with the number of prosumers per coalition, preventing the formation of a grand coalition (which brings the highest savings) and potentially leading to economic dissatisfaction of prosumers. All known post-processing cost-sharing methods are easily implementable and guarantee model convergence. However, and as the results in this paper will show, they are defined so that they do not guarantee economic benefits to all community members as opposed to staying in traditional supplier-household contracts. To bridge this gap the paper defines a new two-stage post-processing cost-sharing method that guarantees lower costs for all energy community members.

- The flexibility of the end-users is often neglected or is not sufficiently modelled. Only a few papers focus on this and model both the household level batteries and controllable smart home devices, such as [8], [19], [20], [24]. Other papers either model only the battery storage or focus more on MES aspects [28]–[34]. However, none of them considers post-processing cost-sharing methods in their analyses.
- Although some papers include uncertainty aspects in their modeling, none of them models static, post-event cost-sharing methods to deal with this important feature of low-carbon energy systems. Additionally, to the authors' knowledge, none of the papers models flexibility incentives for the end-users which award those ready to change their consumption to benefit the power system.

According to [42], an energy community is a legal entity based on voluntary participation with the primary purpose of providing environmental, economic, or social community benefits for its members or the local areas, rather than solely financial profits. Real-world examples of energy communities are Bioenergy Village Jühnde, Brixton Energy, Energy Cooperative of Karditsa, Green Energy Cooperative (ZEZ) [43], etc. The work in this paper considers an energy community operated by a CM whose members have the possibility of p2p energy trading with internal prices determined based on both DA prices and flexibility incentives reflecting regulating power costs.

This paper seeks to investigate the financial benefits arisen from participating in an energy community and demonstrates under which conditions the new market concepts enable cost savings for prosumers. Nowadays, trading with the supplier solely is the most realistic choice for energy procurement. However, due to the growing integration of distributed RES and the liberalization of the retail energy market, energy communities are becoming more and more popular. Community members are becoming active market participants with multiple choices for energy purchase/sale, instead of only one dominant supplier, which is, for example, one of

TABLE 1. Comparison of literature review.

Reference	Battery	Other flexibility	Direct optimization	Uncertainty	Cost-sharing method
[7]	No	No	No	No	min-max import share
[8]	Yes	Yes	No	No	a game theory-based approach, no negotiation between peers
[11]	No	No	No	No	MMR based on a canonical coalition game
[12]	Yes	No	No	No	a coalition formation game
[22]	No	No	Yes	No	BS, MMR, APS
[23]	Yes	No	Yes	No	Not investigated
[13]	Yes	Controllable load	No	Yes	continuous double auction market
[14]	No	No	No	No	double auction market
[15]	Yes	Electric vehicle	No	No	continuous double auction market
[16]	No	No	No	Yes	a game theory-based approach Stackelberg game
[17]	Yes, shared one	No	No	Yes	a game theory-based approach Stackelberg game
[18]	Yes	No	No	No	a game theory-based approach Stackelberg game
[19]	Yes	HVAC Units, Shiftable Electrical Appliances, Flexible Commercial Services	No	Yes	a non-cooperative game
[20]	Yes (EV)	EV, shiftable and adjustable load	No	Yes	Nash bargaining
[21]	Yes	No	No	No	a centralized price setting mechanism to balance supply and demand, ADMM performed by p2p platform agent
[24]	Yes	Non-interruptible appliances, thermostatically controlled appliances, EV	No	No	heuristic
[25]	Yes	Uninterruptible appliance	No	No	ECO-Trade Algorithm
[27]	No	Shiftable load	No	Yes	iterative SDR
[28]	Yes	No	Yes	No	SDR
[29]	Power to gas storage, power to heat storage	CHP, tri-CAES system, demand response	Yes	Yes	no
[30]	Gas storage	Demand response	ϵ -constraint technique	Yes	no
[31]	Battery and thermal storage	CCHP	Yes	Yes	different models ensuring collective or individual interest
[32]	Yes	EV, CHP, demand response	No	No	bidding strategy based on weighted distributing of excess power among consumers
[33]	Battery and thermal storage	CHP, boiler	No	Yes	cost minimization for heat and electricity supply from local markets, no cost-sharing
[34]	Battery and thermal storage	Load shifting	Yes	Yes	the same percentage of cost savings for each microgrid
[35]	Yes	No	Yes	No	bilevel-approach, local market clearing
[36]	Yes	No	Yes	No	p2p market, p2p prices calculated based on desired margin and p2p trader margin
[37]	Yes	No	Yes	No	SDR
[38]	No	No	Yes	No	monthly electricity consumption and self-consumption rate
[39]	Yes	No	No	No	no
[40]	Yes	Load-shifting	Yes	Yes	no
[41]	Yes	No	Yes	Yes	no
This paper	Yes	EV, uninterruptible appliances, thermostatically controllable load,	Yes	Yes	a novel centralized two-stage cost-sharing method

the main objectives of the Clean Energy Package (providing better deals to all end users) established by the European Union [1], [42].

C. CONTRIBUTIONS

Against this background, the contributions of the paper are the following:

1. The proposal of a novel two-stage cost-sharing model that guarantees individual welfare for each community member. After running multiple simulations with different types of prosumers in the energy community, this paper shows that the centralized formulation of the existing/well-known cost-sharing mechanisms (described in [22], [28]) cannot always guarantee that all prosumers are better off in the community. The authors introduce a second stage which defines the minimum bound of cost savings in the community to be shared among community members who are worst off in the community in the first stage which results in lower electricity cost for all community members compared to individual trading with the supplier. The prices are calculated ex-post, the day after energy delivery. In the proposed approach peers do not need to negotiate about the trading volumes and prices and thus the model guarantees the convergence. Both stages in this cost-sharing approach do not interfere with the optimization algorithm, which makes it simple and fast to solve (0.031 seconds for a small test case and 0.172 seconds for the bigger one with 100 prosumers). Although the methods are discussed in previous publications, such as BSM in [22] and [24], this paper provides a systematic analysis and proves the disadvantages of applying the BSM cost-sharing method for prosumers with excess PV production. This is analyzed and evaluated on a small test case with three community members and a realistic test case involving 100 participants (and different configurations regarding the percentage of households equipped with PV, battery storage, and flexible appliances).
2. Unlike papers not considering any kind of flexible behavior [7], [11], [14], [22] or focusing only on battery storage [12], [17], [18], [21]–[23], [28]–[37], [39], this paper investigates the monetary value of several flexible appliances in terms of cost reduction for all community members. The model analyses the impact of different flexible appliances on electricity cost reduction compared to the case with fixed consumption. The existing literature body considers the effect of uncertainty of demand or RES production on the cost [16], battery scheduling in DA and RT optimization [17], adjusting the energy schedule with RT trading with the retailer in order to keep the predefined agreed p2p volume [19], dealing with forecasting error [20], [40], the uncertainty of market prices and demand on the profit due to contract violations between the local energy system and consumers [27], optimal size of battery and PV modules [41]. However, this paper looks into pricing mechanisms stimulating final prosumers equipped with PV and flexible appliances to adjust their RT operational points to predefined DA schedules by explicitly modelling their uncertainty aspects. This creates a proper award system for a flexible and responsive prosumer reflected in a higher cost reduction compared to the current pricing scheme.

D. ORGANIZATION OF THE PAPER

The rest of the paper is organized as follows: Section III describes the differences between individual directly trading with the supplier and collective trading within an energy community represented by the CM. Section IV introduces the two-stage cost-sharing algorithm together with three cost-sharing methods: MMRN, SDRN, and BSMN. Section V describes the case study, while results are analyzed in Section VI. Finally, Section VII concludes the paper.

III. INDIVIDUAL AND COMMUNITY ENERGY SUPPLY

Prosumers today are not responsible for their PV or load forecasting and do not trade directly on the electricity market. Instead, they have a contract signed with the supplier providing them fixed prices, which the supplier offers considering its exposure to both market and its portfolio uncertainties. Together with energy cost, consumers pay network tariffs and balancing costs for each consumed or injected kWh of energy [46]. In recent years, feed-in-tariffs and incentives for household PV integration have been reduced [44]. Consumers are supplied at a higher buying price compared to the price at which they can sell their PV production [8], [23], and [28]. This difference in the buying and selling pricing creates opportunities for consumers to join in an energy community represented by a CM. In the same way, as leaders of balancing groups are responsible for their deviation, the CM also faces balancing costs for the entire community and creates incentive signals to stimulate prosumers to fully utilize their flexibility. Two different approaches of retail market operation are analyzed and compared in this paper. In the first one, each consumer independently trades directly with the supplier, without any interaction with other consumers. In the second approach, consumers join in an energy community represented by a CM who is in charge of trading in the power exchange on their behalf.

A. INDIVIDUAL TRADING WITH THE SUPPLIER

Fig. 1 illustrates the relationship between the supplier and the individual consumers. It is assumed that consumers are not competing against each other or against the supplier.

Consumers are individual entities who sign the contract with their supplier and in this case cannot exchange energy internally. The supplier provides DA buying and selling prices to consumers, while the national transmission system operator charges network and balancing fees (grey one-way arrows). Black, two-way arrows represent power flows (supplier procures energy for prosumers, but also buys excess energy from them).

Each consumer's goal is to minimize their energy procurement cost formulated in (1). They purchase energy from or sell it to the supplier and face a balancing cost for each kWh of procured or sold energy together with the cost for the network usage for procured energy. According to [46], injected energy from PV is not charged with the network fees.

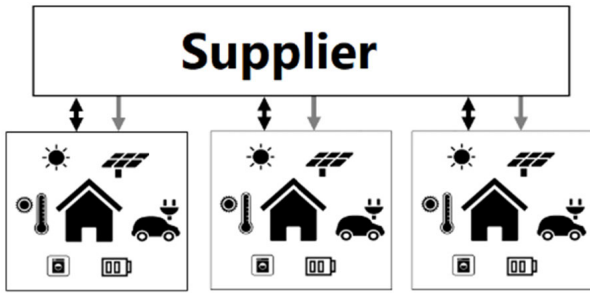

FIGURE 1. Energy and financial flow in directly trading with supplier.

All the scenarios are considered equiprobable.

$$\begin{aligned}
 \min C_d^{ind} \\
 C_d^{ind} = \sum_{t \in T} \Delta t \sum_{s \in S} \pi_s [(\lambda_t^{DAB} + \lambda^{BALB} + \lambda^{NETB}) \cdot P_{d,s,t}^{HDB} \\
 - (\lambda_t^{DAS} - \lambda^{BALS}) \cdot P_{d,s,t}^{HDS}] \quad (1)
 \end{aligned}$$

In scenario s , each consumer net load is divided in imported $P_{d,s,t}^{HDB}$ and exported $P_{d,s,t}^{HDS}$ at time step t (2). The variables representing trading power are greater than zero (3).

$$P_{d,s,t}^{HD} = P_{d,s,t}^{HDB} - P_{d,s,t}^{HDS} \quad (2)$$

$$P_{d,t}^{HDB}, P_{d,t}^{HDS} \geq 0 \quad (3)$$

The power balance equation for consumer d is formulated in (4). The demand of each consumer is composed of must-serve load, flexible uninterruptible appliances (ap stands for washing machine, dishwasher, and dryer), flexible charging of EV, flexible thermal load, and a small battery. The demand can be supplied from rooftop PV or bought from the supplier. If there is an excess PV production, it is sold to the supplier ($P_{d,s,t}^{HD} < 0$).

$$\begin{aligned}
 P_{d,s,t}^{HD} + PV_{d,s,t} = P_{d,s,t}^{ms} + \sum_{ap \in A} P_{d,s,t}^{uniap} \\
 + P_{d,s,t}^{EV} + P_{d,s,t}^{th} + P_{d,s,t}^{ch} - P_{d,s,t}^{dis} \quad (4)
 \end{aligned}$$

The flexible charging of EVs is modelled by inequality constraints (5)-(6):

$$\underline{E}_d \leq \sum_{t \in T} \Delta t \cdot P_{d,s,t}^{EV} \leq \bar{E}_d \quad (5)$$

$$\begin{aligned}
 P_{d,s,t}^{EV} \leq \bar{P}_d, \text{ if } H_d^a \leq t \leq H_d^l \\
 P_{d,s,t}^{EV} = 0, \text{ otherwise} \quad (6)
 \end{aligned}$$

EVs' state of energy when leaving the home is defined by consumers' preferences and modelled by way of (5), while the maximum charging power is enforced by (6). Charging is allowed only during the hours when the car is parked at home.

The supply of flexible uninterruptible appliances is modelled with (7)-(8). The sum of all binary variables indicating when the appliance is started is equal to 1, which ensures that the appliance is started once a day in (7).

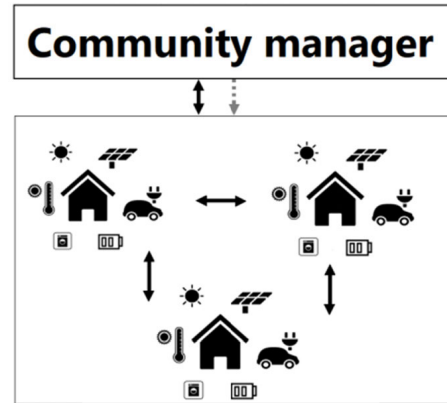

FIGURE 2. Energy and financial flow in energy community trading.

Equation (8) guarantees that, when the appliance is started, the cycle cannot be interrupted.

$$\sum_{t=1}^{T-L^{ap}} x_{d,s,t}^{uni\ ap} = 1 \quad (7)$$

$$P_{d,s,t}^{uni\ ap} = \sum_{l=0}^{L^{ap}-1} x_{d,s,t-l}^{uni\ ap} \cdot P^{uni\ ap} \quad (8)$$

Flexible thermal loads are modelled as in [47]. Outside temperature is considered as an input parameter, while room, floor, and water temperature inside a water tank connected to a heat pump are variables used for modelling heating dynamics. Minimum and maximum bounds of room temperature are described in Section V.

Each household is equipped with battery storage modelled with a non-constant charging ability depending on the battery state of energy. The resulting non-linear charging curve piecewise approximated with three segments of decreasing slope as the battery state of energy increases. The reader is referred to [48] for a precise mathematical formulation of batteries.

B. ENERGY COMMUNITY

In the energy community, consumers exchange surplus of energy among themselves. The difference in the buying and selling prices offered by the supplier creates opportunities for the consumers to benefit from joining an energy community. They are represented by the CM who buys and sells energy from the supplier and faces balancing costs for deviations of end-consumers' announced profiles. CM uses a centralized approach to determine the behavior of all the consumers' flexible appliances in RT in order to reduce the electricity cost of the whole community and thus, of each consumer. The consumers within the community exchange their surplus of electricity with their peers and do not negotiate about trading volume and prices. The grey arrow in Fig. 2 represents the buying and selling prices sent out by the CM to the consumers *ex-post* (that is, the day after the actual exchange of energy. Trading between communities is outside the scope of this paper.

The mathematical model that determines community's cost is given by (9)-(12). The CM minimizes the energy procurement cost for the entire community (minus the profit from selling PV excess) and faces the penalization cost for the energy deviations incurred by the cooperative (9)-(11) and network charges. The community is treated as one single entity (12).

$$\min \sum_{t \in T} \Delta t [\lambda_t^{DAB} \cdot P_t^{DAB} - \lambda_t^{DAS} \cdot P_t^{DAS} + \sum_{s \in S} \pi_s (\lambda_t^{UP} \cdot P_{s,t}^{UP} - \lambda_t^{DOWN} \cdot P_{s,t}^{DOWN}) + \lambda^{NETB} \cdot P_{s,t}^+] \quad (9)$$

$$P_{s,t}^{GRID} = P_t^{DAB} - P_t^{DAS} + P_{s,t}^{UP} - P_{s,t}^{DOWN} \quad (10)$$

$$P_t^{DAB}, P_t^{DAS}, P_{s,t}^{UP}, P_{s,t}^{DOWN}, P_{s,t}^{net pos}, P_{s,t}^{net neg} \geq 0 \quad (11)$$

$$P_{s,t}^{GRID} = P_{s,t}^{net pos} - P_{s,t}^{net neg} = \sum_{d \in D} (P_{d,s,t}^{ms} + \sum_{ap \in A} P_{d,s,t}^{umi ap} + P_{d,s,t}^{EV} + P_{d,s,t}^{th} + P_{d,s,t}^{ch} - P_{d,s,t}^{dis} - PV_{d,s,t}) \quad (12)$$

Furthermore, optimization problem (9)-(12) also includes the consumers' constraints (5)-(8), as well as thermal heating and battery storage.

IV. COST-SHARING MECHANISMS

The optimization algorithm in this approach is a centralized one, i.e., the CM schedules the flexible appliances of community members to achieve lower electricity costs. The excess PV production in the community is firstly shared among community members and the rest is traded on the central power exchange. The main advantage of this approach is that final consumers do not need to negotiate about the trading volumes and prices or individually schedule their appliances. The CM is in charge of scheduling flexible appliances and computes the prices based on their net-load and defined cost-sharing methods. The internal trading prices are calculated outside the optimization algorithm, the day after energy delivery, which makes the optimization algorithm simple to solve and it guarantees the convergence which will ensure the broad integration of this cost-sharing approach. The electricity procurement cost of the energy community is shared among its members based on their net-load in hour t and scenario s . The cost allocation is conducted when the daily operation is completed (that is, at the beginning of the day n , the cost incurred in day $n-1$ is allocated). Therefore, the cost-sharing process does not interfere with the optimization problem, which makes it simple and fast to solve. The only information needed for the cost allocation among the community members is their net-load measured at the end-consumers' smart meter (13):

$$P_{d,s,t}^{net} = P_{d,s,t}^{ms} + \sum_{ap \in A} (P_{d,s,t}^{umi ap} + P_{d,s,t}^{EV} + P_{d,s,t}^{th} + P_{d,s,t}^{ch} - P_{d,s,t}^{dis} - PV_{d,s,t}) \quad (13)$$

As the CM faces a penalization cost due to imperfect net-load forecasts, the average cost of energy in time step t and scenario s $\lambda_{s,t}^{unit}$ is given by (14):

$$\lambda_{s,t}^{unit} = \frac{\lambda_t^{DAB} \cdot P_t^{DAB} - \lambda_t^{DAS} \cdot P_t^{DAS}}{P_{s,t}^{GRID}} + \frac{\lambda_t^{UP} \cdot P_{s,t}^{UP} - \lambda_t^{DOWN} \cdot P_{s,t}^{DOWN}}{P_{s,t}^{GRID}} \quad (14)$$

The first stage redefines existing cost-sharing mechanisms and bases them on consumers' net-load and their technical characteristics. Nowadays, when feed-in tariffs for PV are gradually decreasing, the installation and implementation of net-metering (single four-quadrant meter) are perfectly viable [44] and [45]. Unlike [22] and [24], where internal community prices in MMR and BSM (similar is the case for SDR in [28]) are computed based on the total community's consumption and generation, in the proposed approach the consumers pay or get paid based on their net-load in scenario s and time period t . This means that consumers only sell surplus or buy deficit of energy, differently from the existing research, where they sell their entire PV production and buy their entire demand (not deficit). The second stage describes the benefit reallocation if any of the community members face higher costs in the community.

A. PRICES CALCULATION IN THE FIRST STAGE

1) BILL SHARING METHOD NET

The Bill Sharing Method Net (BSMN) is based on allocating the electricity cost among consumers based on their contribution to the total community cost. In each time period t and scenario s , the community cost is divided among consumers who contribute to energy purchase. It uses the ratio between the total community electricity import and the sum of all the individual positive net-loads if the community purchases energy, and on the ratio between the total community export and the sum of the all individual negative net-loads if the community sells energy. As an upgrade of [22], this paper uses dynamic pricing and flexible appliances and reformulates the mechanism in terms of net-load unlike [24]. Furthermore, for the first time, the disadvantage of BSMN for consumers with an excess PV production is explained.

The total net import (15) and export (16) of the community are calculated *ex-post* as follows:

$$P_{s,t}^{net pos} = \sum_{d \in D} P_{d,s,t}^{net}, \text{ if } P_{d,s,t}^{net} > 0 \quad (15)$$

$$P_{s,t}^{net neg} = \sum_{d \in D} P_{d,s,t}^{net}, \text{ if } P_{d,s,t}^{net} < 0 \quad (16)$$

If the community purchases energy in hour t , the price for consumers who have a deficit of energy is calculated as (17):

$$\lambda_{s,t}^{BSMN B} = \lambda_{s,t}^{unit} \cdot \frac{P_{s,t}^{GRID}}{P_{s,t}^{net pos}} \quad (17)$$

It can be noticed that consumers who have an excess of electricity are not remunerated if that electricity is

shared/consumed within the community. Since the community in the above case has a deficit of energy, the cost of procuring energy is shared among consumers who contribute to the deficit. If, on the contrary, the community sells energy in hour t , the price for consumers who have excess energy is computed as (18):

$$\lambda_{s,t}^{BSMNS} = \lambda_{s,t}^{unit} \cdot \frac{P_{s,t}^{GRID}}{P_{s,t}^{net\ neg}} \quad (18)$$

In this case, consumers who have a deficit of energy are supplied at zero cost. Finally, if the community is in balance, the electricity procurement cost is 0 (the community neither needs to sell or buy) and consumers do not pay or do not get paid.

2) MID-MARKET RATE NET SCHEME

In the case of the Mid-Market Rate Net (MMRN) scheme, the internal buying and selling prices are affected by the amount of energy exchanged within the community. Consumers with a deficit of energy pay and the ones with excess energy are getting paid at a price that is determined based on how much of the energy is consumed within the community and how much from the supplier. Unlike [22], in this paper consumers are exposed to dynamic prices to fully exploit their flexibility. Moreover, MMR is redefined from [22] and [24] and the internal price calculation is based on the individual net-load of consumers. Three different cases are considered, depending on whether the community is in balance, buys or sells energy.

1) The community is in balance ($P_{s,t}^{GRID} = 0$).

In the case that the community is in balance and, hence, there is no exchange of energy with the grid, the internal buying and selling prices in hour t are the same. More specifically, they are equal to the average value between the DA buying and selling prices (19):

$$\lambda_{s,t}^{MMRNB} = \lambda_{s,t}^{MMRNS} = \frac{\lambda_t^{DAB} + \lambda_t^{DAS}}{2} \quad (19)$$

Additionally, as $P_{s,t}^{GRID}$ is equal to zero, the average cost of energy cannot be calculated as in (14). The penalization cost associated with the realization of scenario s is given by (20):

$$cost_{s,t}^{pen} = \lambda_t^{DAB} \cdot P_t^{DAB} - \lambda_t^{DAS} \cdot P_t^{DAS} + \lambda_t^{UP} \cdot P_{s,t}^{UP} - \lambda_t^{DOWN} \cdot P_{s,t}^{DOWN} \quad (20)$$

An equal amount of cost is allocated to each community member (that is, the cost is divided according to the number of consumers in the community).

2) The community buys energy ($P_{s,t}^{GRID} > 0$).

If the community takes energy from the grid, the consumers who have excess energy ($P_{d,s,t}^{net} < 0$), are paid at the price (21):

$$\lambda_{s,t}^{MMRNS} = \frac{\lambda_{s,t}^{unit} + \lambda_t^{DAS}}{2} \quad (21)$$

In contrast, consumers who have a deficit of energy pay a price based on the ratio of the total community import and the total positive and negative net-loads in the community (22):

$$\lambda_{s,t}^{MMRNB} = \frac{\lambda_{s,t}^{unit} \cdot P_{s,t}^{GRID} + \lambda_{s,t}^{MMRNS} \cdot |P_{s,t}^{net\ neg}|}{P_{s,t}^{net\ pos}} \quad (22)$$

Notice that the community energy deficit $P_{s,t}^{net\ pos}$ is covered with the purchase of energy from the supplier $P_{s,t}^{GRID}$ and/or with the excess PV production within the community $P_{s,t}^{net\ neg}$. As the internal selling price $\lambda_{s,t}^{MMRNS}$ is lower than the average cost of energy from the supplier $\lambda_{s,t}^{unit}$ (see (21)), the larger the amount of energy exchanged within the community, the lower the internal buying price $\lambda_{s,t}^{MMRNB}$.

3) The community sells energy ($P_{s,t}^{GRID} < 0$).

If the community sells energy, the consumers who have a deficit of energy ($P_{d,s,t}^{net} > 0$), pay the average price (23):

$$\lambda_{s,t}^{MMRNB} = \frac{\lambda_t^{DAB} + \lambda_{s,t}^{unit}}{2} \quad (23)$$

On the other hand, consumers who have excess energy get paid based on the ratio of the total community export and the total positive and negative net-loads in the community (24):

$$\lambda_{s,t}^{MMRNS} = \frac{\lambda_{s,t}^{unit} \cdot |P_{s,t}^{GRID}| + \lambda_{s,t}^{MMRNB} \cdot P_{s,t}^{net\ pos}}{|P_{s,t}^{net\ neg}|} \quad (24)$$

The summation of all the surpluses of PV production $P_{s,t}^{net\ neg}$ is sold to the supplier $P_{s,t}^{GRID}$ or exchanged with the community members $P_{s,t}^{net\ pos}$. As the internal buying price $\lambda_{s,t}^{MMRNB}$ is higher than the average selling price provided by the supplier $\lambda_{s,t}^{unit}$, the larger the amount of energy exchanged within the community, the higher the internal selling price $\lambda_{s,t}^{MMRNS}$.

3) SUPPLY DEMAND RATIO NET SCHEME

The Supply-Demand Ratio ($SDR_{s,t}$) is defined as the ratio between the negative and positive net-loads in the community (25):

$$SDR_{s,t} = \frac{|P_{s,t}^{net\ neg}|}{P_{s,t}^{net\ pos}} \quad (25)$$

Differently from [18], this paper considers the stochastic nature of demand, PV production, and outside temperature, and therefore, SDRN is based on consumers' net-load instead. Five possible situations may occur:

1. $P_{s,t}^{net\ pos} = 0$ and $SDR_{s,t} = \infty$.

Each consumer in the community has a surplus of PV production. In that situation, the selling price under the SDRN scheme is equal to the average cost of energy in scenario s and time t (26):

$$\lambda_{s,t}^{SDRNS} = \lambda_{s,t}^{unit} \quad (26)$$

2. $SDR_{s,t} = 0$.

Each consumer in the community has a deficit of energy. The community has to buy energy from the supplier and each consumer pays the average cost of energy in scenario s and time step t (27):

$$\lambda_{s,t}^{SDRN B} = \lambda_{s,t}^{unit} \quad (27)$$

3. $SDR_{s,t} = 1$.

If the community self-balances and does not procure or sell energy from the grid in time step t and scenario s , the internal buying and selling prices are both the same (28):

$$\lambda_{s,t}^{SDRN S} = \lambda_{s,t}^{SDRN B} = \lambda_t^{DAS} + \lambda_{s,t} \quad (28)$$

where $\lambda_{s,t}$ is a compensation rate guaranteeing that the consumers are always better off in the community. Its value can be in the range $[0, \lambda_t^{DAB} - \lambda_t^{DAS}]$ [28]. This value will be defined in the case study.

4. $SDR_{s,t} > 1$.

If the community has a surplus of energy and some consumers have positive net-load, the internal selling and buying prices determined by the CM in time step t and scenario s are (29)-(30):

$$\lambda_{s,t}^{SDRN S} = \lambda_{s,t}^{unit} + \frac{\lambda_{s,t}}{SDR_{s,t}} \quad (29)$$

$$\lambda_{s,t}^{SDRN B} = \lambda_{s,t}^{unit} + \lambda_{s,t} \quad (30)$$

5. $0 < SDR_{s,t} < 1$.

If the community has a deficit of energy (which must be purchased from the supplier), but some consumers have a surplus of PV production that is consumed locally, the internal selling and buying prices are calculated as follows (31)-(32):

$$\lambda_{s,t}^{SDRN S} = \frac{\lambda_{s,t}^{unit} \cdot (\lambda_t^{DAS} + \lambda_{s,t})}{(\lambda_{s,t}^{unit} - \lambda_t^{DAS} - \lambda_{s,t}) \cdot SDR_{s,t} + \lambda_t^{DAS} + \lambda_{s,t}} \quad (31)$$

$$\lambda_{s,t}^{SDRN B} = \lambda_{s,t}^{SDRN S} \cdot SDR_{s,t} + \lambda_{s,t}^{unit} \cdot (1 - SDR_{s,t}) \quad (32)$$

B. BENEFIT REALLOCATION IN THE SECOND STAGE

The results presented in this paper have shown that the mathematical formulation of existing direct cost-sharing methods does not always favor participation in the energy community, but rather result in lower cost if the prosumer individually signs a dynamic price contract with the supplier. For this reason, the paper proposes the second stage for the existing direct cost-sharing methods. This second stage is executed in case any of the prosumers face higher cost C_d^{comm} when being a member of the community compared to the individual supplier cost C_d^{ind} . The logic of the improved direct cost-sharing concept is as follows:

1. The first stage is conducted as described in Section IV A.
2. Each community member allocated cost (under m cost-sharing method) is compared to the cost it would receive if staying with the supplier (33). C_d^{ind} can easily

be calculated as all price parameters are transparent and publicly available on a DA base.

$$\Delta_d = C_d^{ind} - C_d^{comm}, \quad \forall d \in D \quad (33)$$

3. If all community members are paying less compared to staying with the supplier, the algorithm stops. If any community member is worst off in the community, the second stage is initiated.
4. The sum of the positive cost difference C^+ is calculated in (34), i.e., for all prosumers who are better off in the community. The sum of the negative cost difference C^- is calculated in (35), i.e., for all prosumers who are worst off in the community.

$$C^+ = \sum_{d \in D^+} \Delta_d \quad \text{if } \Delta_d \geq 0 \quad (34)$$

$$C^- = \left| \sum_{d \in D^-} \Delta_d \right| \quad \text{if } \Delta_d < 0 \quad (35)$$

5. If $C^+ \geq C^-$, the benefits are distributed between community members as described in (36) and (37). This ensures that they are at least equally well off as they would be in the traditional supplier contracts. The logic of this distribution is based on the concept of *minimum bound*. This minimum bound, defined by a range in (36), is a concept that guarantees that for the values between the lower and the upper limit each end-user will have at least the same cost as in the case of having the contract with the supplier. For any value in between the end-user will be better off in the community. The same value of minimum bound has to be chosen for each consumer in benefit reallocation. The cost of community members in the second stage is calculated in (37a) and (37b).

if $C^+ \geq C^-$:

$$\frac{C^-}{C^+} \leq \min \text{ bound} \leq 1 \quad (36)$$

if $\Delta_d \geq 0$:

$$C_d^{new+} = C_d^{comm} + \min \text{ bound} \cdot \Delta_d, \quad (37a)$$

if $\Delta_d < 0$:

$$C_d^{new-} = C_d^{comm} - \frac{|\Delta_d|}{C^-} \cdot \sum_{d \in D^+} (C_d^{new+} - C_d^{comm}), \quad (37b)$$

6. If $C^+ < C^-$, the benefits cannot be reallocated under m cost-sharing method which makes it a non-preferable cost-sharing method.

V. CASE STUDY

For the analyses that follow, two prosumers and a flexible consumer are considered. All three have flexible thermal heating, flexible uninterruptible appliances (washing machine, dishwasher, and dryer), a battery (4kWh), and a smart EV charger (3.7 kW) with the same EV battery capacity

(30 kWh). The power of the washing machine, the dryer, and the dishwasher is 2 kW, 2.5 kW, and 1.9 kW, respectively, while the cycle length of each appliance is 3 h, 2h, and 1h, in that order. For the modeling of the thermal heating, an upper temperature bound is set at 25 °C for each household, while the lower bound depends on the consumers' preferences on the assumption that they allow for a lower temperature at night or when not at home.

Prosumer 1: Car 1 is parked at home between hour 23 and hour 6 in the morning, while E_1 at the end of the charging period is set at 25.9 kWh ($H_1^a = 23, H_1^l = 6$). Consumer 1 sets the lower temperature bound at 19°C from hour 21 to 6 in the morning, and 22 °C for the rest of the day.

Consumer 2: Car 2 is parked at home between hour 18 and 7 ($E_2 = 22.2kWh$). Consumer 2 sets the lower temperature bound at 20°C during hours 23-9, and at 23 °C during the rest of the day.

Prosumer 3: Car 3 is connected to the charger between hours 17 and 8 ($E_3 = 29.6kWh$). Consumer 3 requires an indoor temperature of at least 18°C from hour 23 to 13, while 21°C is set as the lower bound during the rest of the day.

Albeit the minimum and maximum temperature bounds are set as fixed parameters, uncertainty related to thermal heating is considered through different scenarios of the outside temperature. Three different cases of PV production are considered with six possible scenarios each: high (black discontinuous line), medium (dark grey dotted line), and low (light grey color) as depicted in Fig. 3. PV and temperature measurements are taken from a PV panel placed on the rooftop of a laboratory in Zagreb and grouped to fit in the three previously mentioned cases.

DA buying (black) and selling (grey) prices, as well as up (black dotted) and down incentive prices (grey dotted) are presented in Fig. 4. The difference in the buying and selling prices offered by the supplier actually represents the real situation in some countries like Denmark. The Danish supplier Orsted offers dynamic selling prices to the final consumers [49], while the surplus of PV production is sold at the market price (Nordpool [50]). According to the proposal of the market design in the European directive [42], more transparent RT price signals (which reflect the DA market prices) stimulate consumers to change their consumption, either individually or through aggregation. This results in increased flexibility that facilitates the transition towards a carbon-neutral power system. Danish prices are taken as an example due to data availability, however other countries in the EU have already implemented dynamic tariffs for end-users (such as Red Eléctrica in Spain [51] or 7H Kraft in Sweden [52]). The approach used in this paper is not country-specific, but rather general enough for the entire EU. Network charge for supplied kWh is set at 9.7 ORE/kWh while balancing cost in directly trading with the supplier is set at 0.197 ORE/kWh for purchased energy and 0.112 ORE/kWh for sold energy [46]. Up and down incentive prices encourage prosumers in the energy community to follow their

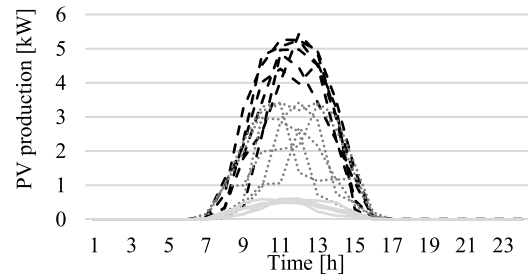

FIGURE 3. Aggregated PV production.

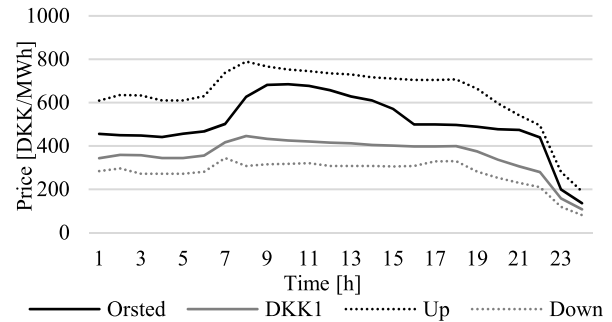

FIGURE 4. DA buying/selling prices, up/down flexibility incentives.

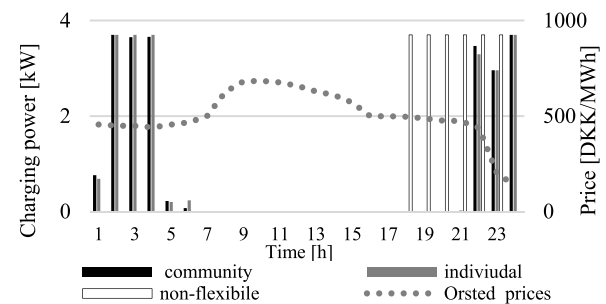

FIGURE 5. Flexible and non-flexible charging of EV – consumer 2.

predefined DA schedule instead of paying the balancing cost for each bought or sold kWh of energy.

If the energy community has a deficit of energy with respect to the committed DA schedule, it will pay the difference at the up price, which is higher than the DA buying price. On the other hand, if a consumer has a surplus of energy, they will sell the difference from the scheduled amount at the down-price, which is lower than the DA selling price.

VI. RESULTS

In this section, the monetary value of implementing a flexible EV charging and a flexible start-up time of uninterruptible appliances is assessed. Further, the analysis shows for which case of PV production consumers are always better off in the community and elaborates which cost-sharing scheme is preferable for different types of consumers.

A. BENEFITS OF FLEXIBLE PROSUMPTION

The flexible scheduling of domestic appliances results in a significant cost reduction compared to the case when the

TABLE 2. Averaged cost reduction (in %) (computed over the set of scenarios) in the case of a high PV production with flexible appliances.

Consumer	1	2	3
Supplier	-8.18	-11.32	-10.34
Community	MMRN	-8.62	-11.00
	SDRN	-8.71	-11.37
	BSMN	-6.99	-19.72

EV charging and the start of uninterruptible appliances are not flexible. In the non-flexible scenario, it is supposed that the charging of the EV is started from the very moment the car arrives home. The car is being charged at maximum charging power until the desired battery state of energy is reached. Besides, the starting times of the washing machine, the dryer, and the dishwasher are fixed to 18 h, 21 h, and 23 h, respectively. On the other hand, in the flexible regime, the operation of each appliance is determined by the CM scheduling algorithm in accordance with the predefined comfort zones of consumers. The average cost reduction in percentage for each consumer in the case of high PV production is shown in Table 2. The first row in this table provides the cost reduction for the instance in which each consumer trades directly with the supplier, while the remaining rows in the table pertaining to the different cost-sharing mechanisms in the community that have been described in Section IV. As can be seen in Table 2, smart charging of EV and flexible starting time of uninterruptible appliances can significantly reduce the end-user cost (from 3% to almost 20% cost reduction in flexible regime). The highest cost reduction achieves consumer 2 who does not have PV installed.

Average (over the observed set of scenarios) charging powers of EVs under the flexible and non-flexible case studies are compared in Fig. 5 for consumer 2. Non-flexible charging is set from hour 18. The car is being charged at the maximum power of 3.7 kW for 6 hours to reach the desired state of charge, which is set at 22.2 kWh. Compared to flexible charging, which considers prices, one can notice that cost reduction in the flexible case is achieved by charging the EV in hour 24 and during the morning hours from 0 to 6 am when the prices are lower compared to the early evening prices from hour 18 to 21.

Moreover, in the flexible regime, the start-up time for washing machine, dryer, and dishwasher is at hour 21h, 22h, and 23h, while in non-flexible is set at 18h, 21, and 23h. The biggest cost reduction is achieved by the scheduling of washing machine where the whole washing period of 3 hours is moved to less expensive hours.

B. ANALYSIS OF THE BEST COST-SHARING MECHANISM

Table 3 compares the average cost of procuring electricity by the energy community under the different cost-sharing methods for the three considered cases and the cost linked

to individually trading with the supplier. A fair cost-sharing mechanism is the one that makes all consumers better off within the energy community compared to the individual trading approach with the supplier. As can be seen from Table 3, all community members are better off in the energy community with SDRN and MMRN for the cases of medium and high PV production. In the case of low PV production, prosumer 3 is not always better off within the energy community. Their cost reduction can, in case of high PV production, reach 20% with community trading and cost-sharing under BSMN. In MMRN, if the energy community self-balances, consumers with excess energy get paid more than in the individual trading strategy. In particular, they are paid at the average of the buying and selling prices offered by the supplier, which is higher than the selling price. Likewise, consumers who need to buy get the same average price, which is lower than the buying price. Under SDRN, those consumers with excess energy get a compensation, which is set at $(\lambda_t^{DAB} - \lambda_t^{DAS})/2$. The result is that all the members in the cooperative are awarded for supporting the self-sufficiency of the community.

Table 4 shows the attained cost reduction (if negative) or cost increase (if positive) in percentage under the six scenarios of high PV production. It can be noticed that all consumers are better off in the energy community under SDRN and MMRN. The exception is prosumer 1 in scenario 5, consumer 2 in scenario 4 under MMRN and prosumer 3 in scenario 2 under SDRN (the benefit reallocation in the second stage will be explained further in the text). However, BSMN is only favorable for the consumer without PV as they profit from prosumers with an excess PV production. The energy deficit of consumer 2 is supplied at zero cost from excess PV production from other prosumers resulting in the biggest cost savings. Cost savings for prosumers 1 and 3 under MMRN and SDRN are very similar because they reward excess PV production with higher internal selling prices compared to that of the supplier. The optimal contracts that lead to a win-win situation for all stakeholders are both MMRN and SDRN. For high PV production, prosumers 1 and 3 incur higher electricity costs under BSMN. To further illustrate the disadvantages of BSMN for prosumers with a surplus of PV production, Table 5 shows the electricity procurement costs in DKK for all consumers in hour 10 of scenario 6, under the individual trading setup and the BSMN cost-allocation method that is based on net-load (note that a negative cost represents a profit from selling energy). In this hour, the community does not exchange energy with the grid, while the consumers' net-loads are -0.24kW, 2.4 kW, and -2.16 kW. Consumer 2 takes advantage of the excess PV production from prosumers 1 and 3. Moreover, in the hours when the total net-load of the community is negative, the consumers who contribute to the profit of the community share only the profit for the energy exported outside the community, but not for the energy shared among other community members. In contrast, a consumer with a positive net-load is the one benefiting the most because they do not pay anything for

TABLE 3. Average cost (IN DKK and computed over the respective set of scenarios) of individual vs. community trading under the different cost-sharing methods in the first stage.

Case	High PV			Low PV			Medium PV		
	Consumer	1	2	3	1	2	3	1	2
Supplier	18.89	22.72	19.74	24.84	22.72	24.08	22.18	22.72	21.71
MMRN	18.61	22.53	19.44	24.83	22.67	24.11	21.91	22.33	21.42
SDRN	18.76	22.31	19.60	24.83	22.66	24.12	21.91	22.24	21.51
BSMN	20.22	18.06	21.76	24.92	22.42	24.27	21.99	20.51	23.16

TABLE 4. Cost comparison (in %) under six scenarios of high pv production in the first stage.

Consumer	1			2			3		
	Method	MMRN	SDRN	BSMN	MMRN	SDRN	BSMN	MMRN	SDRN
1	-0.95	-0.84	5.69	-0.17	-1.24	-20.15	-1.68	-0.66	13.15
2	-2.35	-1.92	9.26	-0.28	-2.04	-23.76	-1.56	0.02	14.07
3	-0.83	-0.54	5.79	-1.96	-2.39	-9.63	-1.15	-0.93	1.33
4	-2.89	-2.51	3.90	0.23	-1.01	-23.84	-2.56	-1.42	20.12
5	0.30	0.32	3.91	-1.66	-2.22	-10.29	-0.69	-0.06	5.78
6	-2.25	-1.55	14.40	-1.08	-1.98	-21.46	-1.71	-1.29	7.16

TABLE 5. Cost comparison in individual and bsmn approach.

Consumer	1				2				3			
	Supplier		BSMN		Supplier		BSMN		Supplier		BSMN	
	Netload [kW]	Cost [DKK]	Netload [kW]	Cost [DKK]	Netload [kW]	Cost [DKK]	Netload [kW]	Cost [DKK]	Netload [kW]	Cost [DKK]	Netload [kW]	Cost [DKK]
Hour 10	-0.08	-0.03	-0.24	0	0.18	0.14	2.4	0	-0.90	-0.38	-2.16	0

their energy deficit. The amount of energy consumed within the community reduces the selling price (see Equation (18)), and thus reduces the profit for those consumers with an excess PV production. When the community sells energy, the so-obtained profit is shared among prosumers 1 and 3 (that is, between the consumers who have excess energy). However, prosumers 1 and 3 are paid only for the surplus of PV production that is sold by the CM to the supplier and not for that part of the surplus that is consumed within the community. This means that consumer 2 (without PV) covers their deficit of energy at zero cost.

C. SENSITIVITY STUDIES

The results in Table 6 below show daily costs for each consumer in DKK, under different cost-sharing mechanisms, for a case where all three consumers have a PV panel installed. It can be noticed that regardless of all community members have PV installed and excess PV production, they are better off with MMRN and SDRN, while consumer 2 is worse off with BSMN due to the highest excess PV production. The average of PV production excess during the day for consumer 1 is 2.58 kWh, for consumer 2 is 3.33 kWh, and for consumer 3 is 2.30 kWh.

Furthermore, an additional study is conducted for an energy community consisting of 100 participants. Fig. 6 presents the ratios between the energy cost in the community and the cost in the individual approach, for different

TABLE 6. Average cost comparison when all prosumers have PV (DKK).

Consumer	1	2	3
supplier	20.55	16.30	21.69
MMRN	20.47	16.28	21.44
SDRN	20.50	16.29	21.40
BSMN	20.53	16.85	20.81

percentages of PV share and customer flexibility potential. A lower ratio means that trading within the community is more profitable for the consumer. More specifically, if the ratio is below 1, the consumer is better off within the community, while a ratio bigger than 1 involves the existence of consumers who are better off under the individual trading scheme. Simulations are performed for four cases:

- 1) all community members have PV, battery storage, and the flexible start of uninterruptible appliances (denoted as *flexi uni* in Table 7),
- 2) all community members have PV, 50% of all consumers do not have battery storage or capability to flexibly start uninterruptible appliances,
- 3) 50% of community members have PV, none has a battery and 50% have the flexible start of uninterruptible appliances,
- 4) 50% of community members have PV, battery, and the flexible start of uninterruptible appliances (not necessarily the consumer with PV has flexible appliances as well).

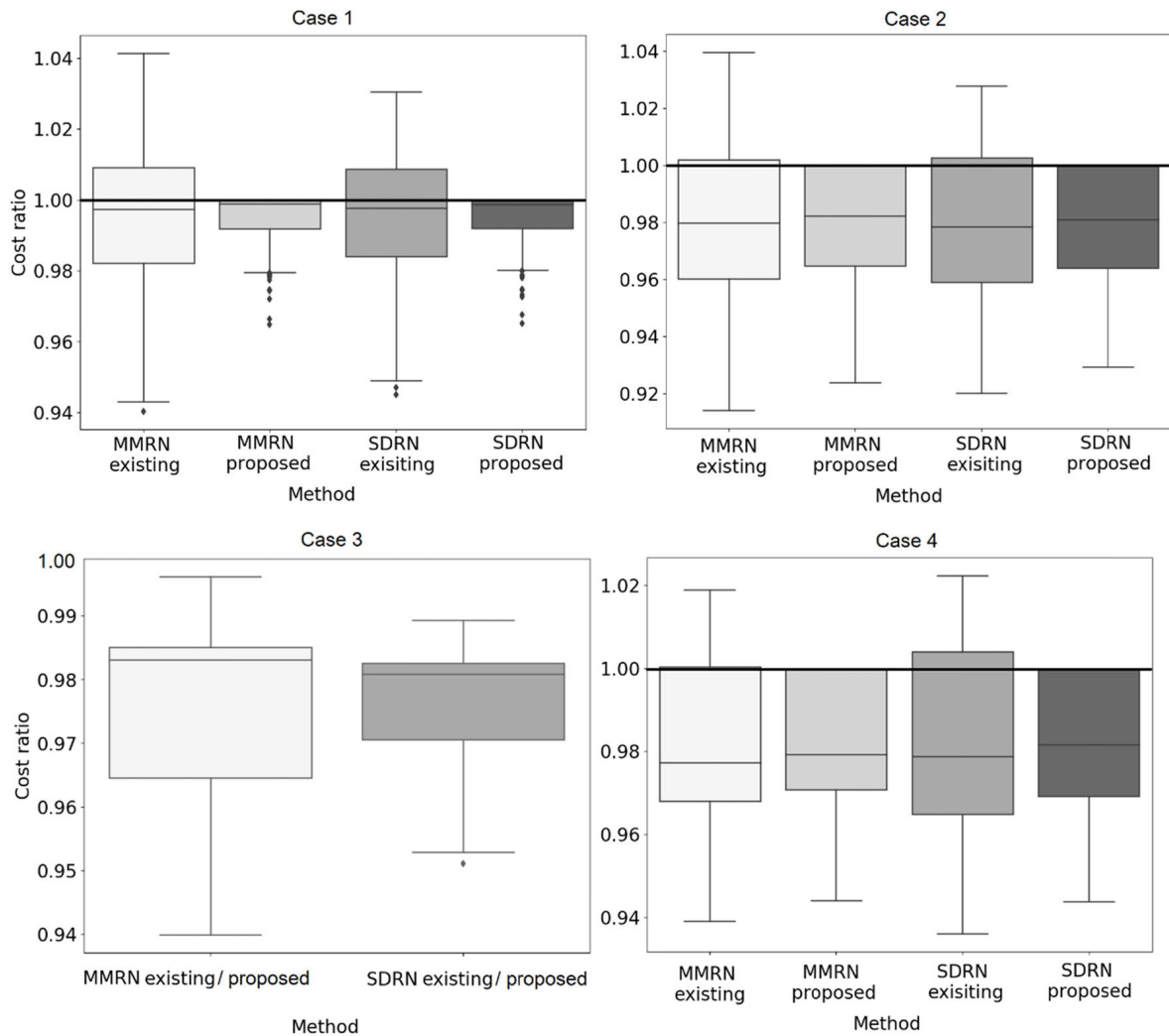

FIGURE 6. Comparison of cost ratios under different pricing mechanism.

TABLE 7. Comparison of cost reduction and cost increase in current and proposed pricing scheme in %.

Method	MMRN		SDRN		BSMN	
Pricing	Current	Proposed	Current	Proposed	Current	Proposed
Cost reduction	5.97 – 8%	3.52 – 7.61%	4.88 – 7.97%	3.52 – 7.07%	30.16 – 32.43%	30.16 – 32.43%
Cost increase	1.90 – 4.14%	0	2.24 – 3.05%	0	19.78 – 25.37%	19.78 – 25.37%

For consumers without the flexible start of uninterruptible appliances, the start-up time is set as explained in Section VI A. In the first stage of the cost-sharing, the internal buying and selling prices according to the three cost-sharing schemes are calculated. The second stage determines the lower value of the benefit reallocation if any of the community members face higher costs in the community. In Case 3 all community members are at least the same or better off in the first stage under the existing MMRN and SDRN. The cost ratio is 1 or lower than 1 which means that there is no need to run the proposed stage 2 of the cost-sharing allocation. On the other hand, one can notice from Fig. 6 in

Cases 1, 2, and 4, some community members are worst off in the energy community under the existing pricing mechanisms (a white boxplot for MMRN and a gray boxplot for SDRN), i.e., their ratio is higher than 1. In these two cases, the second stage is executed ensuring the distribution of benefits as described in Section IV. B. and the results in Fig. 6 show that now all community members face at least the same or lower cost compared to the individual trading with the supplier in all scenarios. Graphs are plotted for the lower limit of the minimum bound which defines the minimum value of cost reduction sharing. All community members have a ratio equal to 1 or lower than 1 in light gray boxplots (MMRN) and dark

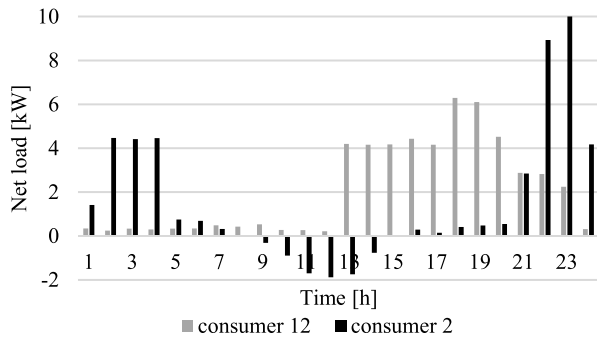

FIGURE 7. Net-load of consumers 2 and 12.

TABLE 8. Reduction in lower bound in % of benefit reallocation in case 4.

Scenario	MMRN	SDRN
1	18.94	49.56
2	37.07	65.59
3	35.50	59.88
4	30.07	48.92
5	32.38	61.53
6	47.43	114.29

gray boxplots (SDRN). Interestingly, it can again be noticed that BSMN is not a preferable method for community trading. BSMN underperforms in all analyzed cases, suggesting this is not a desirable method to be used for cost-sharing in energy communities. The proposed improvements of the original method cannot be applied because $C^+ < C^-$, concluding that the prosumers with excess PV will not be attracted to join the energy community under the BSMN method as their over-production is treated as free electricity for other community members. The total cost increase for prosumers is higher than the total cost reduction in the community, making it impossible to reallocate the benefits among community members to achieve the lower cost for all members. To explain the reason why the BSMN method is not a preferential method in the community participation, the net loads of consumers 2 and 12 in case 4 and under BSMN cost-sharing mechanism are compared. Fig. 7 represents the net-load during the day of consumer 2 and 14 in case 4. It can be noticed in Fig. 7 that consumer 2 has a surplus of PV during the day, which is shared among other community members for free. The total community export in hours 8,9, 14 is zero, whereas consumer 2 is not getting paid at all in hours 9 and 14.

D. THE VALUE OF FLEXIBILITY INCENTIVES

In the current trading with the supplier, consumers pay the balancing cost for each consumed or injected kWh of energy [46] as described in (1). This paper proposes flexibility incentives that encourage the prosumers to follow the predefined DA schedule and minimize paying for regulating up and down power deviations. Additional simulations were run to demonstrate the benefits of the proposed community

pricing with flexibility incentives compared to the current pricing scheme when final prosumers are engaged in the energy community. The results in Table 7 clearly show that under the current cost-sharing calculation of MMRN and SDRN some community members will end up with higher energy bills compared to the individual trading with their supplier. On the other hand, the proposed two-stage method guarantees this will not happen as it evenly distributes the welfare among members. Although in the proposed approach individual cost reduction is lower (5.97 – 8% compared to 3.52 – 7.61%), none of the community members face higher costs. On the other hand, in the current community trading, some community members face up to 4% of a cost increase under MMRN. The results also clearly show that BSMN should not be used as the community cost-sharing method. Table 8 shows the change in minimum bound value between the case in which the energy community pays the balancing cost and the proposed pricing method based on flexibility incentives. Interestingly, this minimum bound cannot be calculated for Case 1 and 2 when the community pays the balancing cost for each kWh of consumed or injected kWh of energy ($C^+ < C^-$). This means that some community members will be worst off in the community. In Case 3, all community members are better off in the community in both types of community pricing. In Case 4 consumers who are better off in the first stage will need to share a lower amount of their cost reduction with other community members. This lower value of minimum bound is reduced by 18-47% in MMRN and 49-114% in SDRN in the proposed pricing which makes it more preferable compared to the current pricing scheme.

VII. CONCLUSION

To raise awareness about energy efficiency, it is important to encourage prosumers and energy communities to consume energy locally and to utilize their flexibility by following price incentives. In order to reduce prosumers' electricity costs, this paper describes an energy community driven by price signals from a CM. The CM contracts buying and selling energy from a DA market and encourages flexible behavior of its community members with incentives that capture the regulating power costs linked to errors in the forecast load and PV production. The allocation of those costs within the community is carried out ex-post (in particular, the day after energy delivery) based on individual net-load measurements and both DA market prices and incentives from the CM. In this approach, consumers do not need to negotiate the exchanged electricity volumes and prices between each other. They share the surplus of energy, while the CM determines the transaction prices the day after. Firstly, the monetary value in terms of decreasing electricity costs with domestic flexible appliances is assessed. The case with fully flexible uninterruptible appliances and EV charging is compared with a non-flexible setup with a predefined starting time of EV charging and uninterruptible appliances resulting in savings between 3 and 20%. Secondly, the paper

investigates the differences and advantages of various cost-sharing mechanisms for prosumers with PV generation and explains the main disadvantages of the BSMN method for prosumers with excess PV production. Excess PV production in the energy community under BSMN is shared at zero cost which benefits only consumers with an energy deficit, while sellers are at a loss. Thirdly, the paper demonstrated that some community members are not always better off with existing MMRN, SDRN, and BSMN cost-sharing methods compared to the individual trading with the supplier. To overcome this issue, the authors propose the second stage in the centralized cost-sharing process which provides the lower bound of cost reduction reallocation to be shared among peers to achieve lower energy cost under MMRN and SDRN. The results show that none of the community members will face increased cost compared to individual trading with the supplier (unlike in current community trading where some members face up to 4% of cost increase in the community). Furthermore, the paper introduces flexibility incentives, reflecting balancing market costs, with the goal to encourage consumer's RT flexible behavior to follow a predefined DA schedule. This results in lowering the value of the minimum bound in benefit reallocation by 18-47% in MMRN and 49-114% in SDRN.

REFERENCES

- [1] *Clean Energy For All Europeans*. Accessed: May 26, 2020. [Online]. Available: https://ec.europa.eu/energy/sites/ener/files/documents/com_860_final.pdf
- [2] K. J. Shin and S. Managi, "Liberalization of a retail electricity market: Consumer satisfaction and household switching behavior in Japan," *Energy Policy*, vol. 110, pp. 675–685, Nov. 2017, doi: [10.1016/j.enpol.2017.07.048](https://doi.org/10.1016/j.enpol.2017.07.048).
- [3] T. Vihalemm and M. Keller, "Consumers, citizens or citizen-consumers? Domestic users in the process of estonian electricity market liberalization," *Energy Res. Social Sci.*, vol. 13, pp. 38–48, Mar. 2016, doi: [10.1016/j.erss.2015.12.004](https://doi.org/10.1016/j.erss.2015.12.004).
- [4] ICF Consultancy Services in Association with DIW. (2015). *The Economic Impact of Enforcement of Competition Policies on the Functioning of EU Energy Markets*. [Online]. Available: <https://op.europa.eu/en/publication-detail/-/publication/45d6dcbe-f18d-11e5-8529-01aa75ed71a1>
- [5] *The Importance of Free Formation of Prices in the European Wholesale Electricity Market*. Accessed: May 26, 2020. [Online]. Available: https://efet.org/Files/Documents/ElectricityMarket/Generalmarketdesignandgovernance/EFET_Free-formation-of-prices-power-market.pdf
- [6] S. Bolwig, G. Bazbauers, A. Klitkou, P. D. Lund, A. Blumberga, A. Gravelins, and D. Blumberga, "Review of modelling energy transitions pathways with application to energy system flexibility," *Renew. Sustain. Energy Rev.*, vol. 101, pp. 440–452, Mar. 2019, doi: [10.1016/j.rser.2018.11.019](https://doi.org/10.1016/j.rser.2018.11.019).
- [7] F. Moret and P. Pinson, "Energy collectives: A community and fairness based approach to future electricity markets," *IEEE Trans. Power Syst.*, vol. 34, no. 5, pp. 3994–4004, Sep. 2019, doi: [10.1109/TPWRS.2018.2808961](https://doi.org/10.1109/TPWRS.2018.2808961).
- [8] S. Noor, W. Yang, M. Guo, K. H. van Dam, and X. Wang, "Energy demand management within micro-grid networks enhanced by blockchain," *Appl. Energy*, vol. 228, pp. 1385–1398, Oct. 2018, doi: [10.1016/j.apenergy.2018.07.012](https://doi.org/10.1016/j.apenergy.2018.07.012).
- [9] C. Zhang, J. Wu, Y. Zhou, M. Cheng, and C. Long, "Peer-to-peer energy trading in a microgrid," *Appl. Energy*, vol. 220, pp. 1–12, Jun. 2018, doi: [10.1016/j.apenergy.2018.03.010](https://doi.org/10.1016/j.apenergy.2018.03.010).
- [10] J. Kim and Y. Dvorkin, "A P2P-dominant distribution system architecture," *IEEE Trans. Power Syst.*, vol. 35, no. 4, pp. 2716–2725, Jul. 2020, doi: [10.1109/tpwrs.2019.2961330](https://doi.org/10.1109/tpwrs.2019.2961330).
- [11] W. Tushar, T. K. Saha, C. Yuen, T. Morstyn, M. D. McCulloch, H. V. Poor, and K. L. Wood, "A motivational game-theoretic approach for peer-to-peer energy trading in the smart grid," *Appl. Energy*, vol. 243, pp. 10–20, Jun. 2019, doi: [10.1016/j.apenergy.2019.03.111](https://doi.org/10.1016/j.apenergy.2019.03.111).
- [12] W. Tushar, T. K. Saha, C. Yuen, M. I. Azim, T. Morstyn, H. V. Poor, D. Niyato, and R. Bean, "A coalition formation game framework for peer-to-peer energy trading," *Appl. Energy*, vol. 261, Mar. 2020, Art. no. 114436, doi: [10.1016/j.apenergy.2019.114436](https://doi.org/10.1016/j.apenergy.2019.114436).
- [13] K. Chen, J. Lin, and Y. Song, "Trading strategy optimization for a prosumer in continuous double auction-based peer-to-peer market: A prediction-integration model," *Appl. Energy*, vol. 242, pp. 1121–1133, May 2019, doi: [10.1016/j.apenergy.2019.03.094](https://doi.org/10.1016/j.apenergy.2019.03.094).
- [14] J. Lin, M. Pipattanasomporn, and S. Rahman, "Comparative analysis of auction mechanisms and bidding strategies for P2P solar transactive energy markets," *Appl. Energy*, vol. 255, Dec. 2019, Art. no. 113687, doi: [10.1016/j.apenergy.2019.113687](https://doi.org/10.1016/j.apenergy.2019.113687).
- [15] Z. Wang, X. Yu, Y. Mu, and H. Jia, "A distributed peer-to-peer energy transaction method for diversified prosumers in urban community micro-grid system," *Appl. Energy*, vol. 260, Feb. 2020, Art. no. 114327, doi: [10.1016/j.apenergy.2019.114327](https://doi.org/10.1016/j.apenergy.2019.114327).
- [16] K. Anoh, S. Maharjan, A. Ikpehai, Y. Zhang, and B. Adebisi, "Energy peer-to-peer trading in virtual microgrids in smart grids: A game-theoretic approach," *IEEE Trans. Smart Grid*, vol. 11, no. 2, pp. 1264–1275, Mar. 2020, doi: [10.1109/TSG.2019.2934830](https://doi.org/10.1109/TSG.2019.2934830).
- [17] N. Liu, M. Cheng, X. Yu, J. Zhong, and J. Lei, "Energy-sharing provider for PV prosumer clusters: A hybrid approach using stochastic programming and stackelberg game," *IEEE Trans. Ind. Electron.*, vol. 65, no. 8, pp. 6740–6750, Aug. 2018, doi: [10.1109/TIE.2018.2793181](https://doi.org/10.1109/TIE.2018.2793181).
- [18] A. Paudel, K. Chaudhari, C. Long, and H. B. Gooi, "Peer-to-peer energy trading in a prosumer-based community microgrid: A game-theoretic model," *IEEE Trans. Ind. Electron.*, vol. 66, no. 8, pp. 6087–6097, Aug. 2019, doi: [10.1109/TIE.2018.2874578](https://doi.org/10.1109/TIE.2018.2874578).
- [19] S. Cui, Y.-W. Wang, and J.-W. Xiao, "Peer-to-peer energy sharing among smart energy buildings by distributed transaction," *IEEE Trans. Smart Grid*, vol. 10, no. 6, pp. 6491–6501, Nov. 2019, doi: [10.1109/TSG.2019.2906059](https://doi.org/10.1109/TSG.2019.2906059).
- [20] K. A. Melendez, V. Subramanian, T. K. Das, and C. Kwon, "Empowering end-use consumers of electricity to aggregate for demand-side participation," *Appl. Energy*, vol. 248, pp. 372–382, Aug. 2019, doi: [10.1016/j.apenergy.2019.04.092](https://doi.org/10.1016/j.apenergy.2019.04.092).
- [21] T. Morstyn and M. D. McCulloch, "Multiclass energy management for peer-to-peer energy trading driven by prosumer preferences," *IEEE Trans. Power Syst.*, vol. 34, no. 5, pp. 4005–4014, Sep. 2019, doi: [10.1109/TPWRS.2018.2834472](https://doi.org/10.1109/TPWRS.2018.2834472).
- [22] C. Long, J. Wu, C. Zhang, L. Thomas, M. Cheng, and N. Jenkins, "Peer-to-peer energy trading in a community microgrid," in *Proc. IEEE Power Energy Soc. Gen. Meeting*, Jul. 2017, pp. 1–5.
- [23] A. Lüth, J. M. Zepter, P. C. del Granado, and R. Egging, "Local electricity market designs for peer-to-peer trading: The role of battery flexibility," *Appl. Energy*, vol. 229, pp. 1233–1243, Nov. 2018, doi: [10.1016/j.apenergy.2018.08.004](https://doi.org/10.1016/j.apenergy.2018.08.004).
- [24] Y. Zhou, J. Wu, and C. Long, "Evaluation of peer-to-peer energy sharing mechanisms based on a multiagent simulation framework," *Appl. Energy*, vol. 222, pp. 993–1022, Jul. 2018, doi: [10.1016/j.apenergy.2018.02.089](https://doi.org/10.1016/j.apenergy.2018.02.089).
- [25] M. R. Alam, M. St-Hilaire, and T. Kunz, "Peer-to-peer energy trading among smart homes," *Appl. Energy*, vol. 238, pp. 1434–1443, Mar. 2019, doi: [10.1016/j.apenergy.2019.01.091](https://doi.org/10.1016/j.apenergy.2019.01.091).
- [26] M. R. Alam, M. St-Hilaire, and T. Kunz, "An optimal P2P energy trading model for smart homes in the smart grid," *Energy Efficiency*, vol. 10, no. 6, pp. 1475–1493, Dec. 2017, doi: [10.1007/s12053-017-9532-5](https://doi.org/10.1007/s12053-017-9532-5).
- [27] N. Liu, X. Yu, C. Wang, C. Li, L. Ma, and J. Lei, "Energy-sharing model with price-based demand response for microgrids of peer-to-peer prosumers," *IEEE Trans. Power Syst.*, vol. 32, no. 5, pp. 3569–3583, Sep. 2017, doi: [10.1109/TPWRS.2017.2649558](https://doi.org/10.1109/TPWRS.2017.2649558).
- [28] C. Long, J. Wu, Y. Zhou, and N. Jenkins, "Peer-to-peer energy sharing through a two-stage aggregated battery control in a community micro-grid," *Appl. Energy*, vol. 226, pp. 261–276, Sep. 2018, doi: [10.1016/j.apenergy.2018.05.097](https://doi.org/10.1016/j.apenergy.2018.05.097).
- [29] M. Z. Oskouei, M. A. Mirzaei, B. Mohammadi-Ivatloo, M. Shafiee, M. Marzband, and A. Anvari-Moghaddam, "A hybrid robust-stochastic approach to evaluate the profit of a multi-energy retailer in tri-layer energy markets," *Energy*, vol. 214, Jan. 2021, Art. no. 118948, doi: [10.1016/j.energy.2020.118948](https://doi.org/10.1016/j.energy.2020.118948).

- [30] M. Nazari-Heris, M. A. Mirzaei, B. Mohammadi-Ivatloo, M. Marzband, and S. Asadi, "Economic-environmental effect of power to gas technology in coupled electricity and gas systems with price-responsive shiftable loads," *J. Cleaner Prod.*, vol. 244, Jan. 2020, Art. no. 118769, doi: [10.1016/j.jclepro.2019.118769](https://doi.org/10.1016/j.jclepro.2019.118769).
- [31] M. Daneshvar, B. Mohammadi-Ivatloo, S. Asadi, A. Anvari-Moghaddam, M. Rasouli, M. Abapour, and G. B. Gharehpetian, "Chance-constrained models for transactive energy management of interconnected microgrid clusters," *J. Cleaner Prod.*, vol. 271, Oct. 2020, Art. no. 122177, doi: [10.1016/j.jclepro.2020.122177](https://doi.org/10.1016/j.jclepro.2020.122177).
- [32] H. R. Gholinejad, A. Loni, J. Adabi, and M. Marzband, "A hierarchical energy management system for multiple home energy hubs in neighborhood grids," *J. Building Eng.*, vol. 28, Mar. 2020, Art. no. 101028, doi: [10.1016/j.jobte.2019.101028](https://doi.org/10.1016/j.jobte.2019.101028).
- [33] M. Jadidbonab, B. Mohammadi-Ivatloo, M. Marzband, and P. Siano, "Short-term self-scheduling of virtual energy hub plant within thermal energy market," *IEEE Trans. Ind. Electron.*, vol. 68, no. 4, pp. 3124–3136, Apr. 2021, doi: [10.1109/tie.2020.2978707](https://doi.org/10.1109/tie.2020.2978707).
- [34] M. Daneshvar, B. Mohammadi-ivatloo, K. Zare, S. Asadi, and A. Anvari-Moghaddam, "A novel operational model for interconnected microgrids participation in transactive energy market: A hybrid IGDT/Stochastic approach," *IEEE Trans. Ind. Informat.*, early access, Jul. 28, 2021, doi: [10.1109/tii.2020.3012446](https://doi.org/10.1109/tii.2020.3012446).
- [35] B. Cornélusse, I. Savelli, S. Paoletti, A. Giannitrapani, and A. Vicino, "A community microgrid architecture with an internal local market," *Appl. Energy*, vol. 242, pp. 547–560, May 2019, doi: [10.1016/j.apenergy.2019.03.109](https://doi.org/10.1016/j.apenergy.2019.03.109).
- [36] S. Nguyen, W. Peng, P. Sokolowski, D. Alahakoon, and X. Yu, "Optimizing rooftop photovoltaic distributed generation with battery storage for peer-to-peer energy trading," *Appl. Energy*, vol. 228, pp. 2567–2580, Oct. 2018, doi: [10.1016/j.apenergy.2018.07.042](https://doi.org/10.1016/j.apenergy.2018.07.042).
- [37] D. L. Rodrigues, X. Ye, X. Xia, and B. Zhu, "Battery energy storage sizing optimisation for different ownership structures in a peer-to-peer energy sharing community," *Appl. Energy*, vol. 262, Mar. 2020, Art. no. 114498, doi: [10.1016/j.apenergy.2020.114498](https://doi.org/10.1016/j.apenergy.2020.114498).
- [38] J. An, M. Lee, S. Yeom, and T. Hong, "Determining the peer-to-peer electricity trading price and strategy for energy prosumers and consumers within a microgrid," *Appl. Energy*, vol. 261, Mar. 2020, Art. no. 114335, doi: [10.1016/j.apenergy.2019.114335](https://doi.org/10.1016/j.apenergy.2019.114335).
- [39] M. Ruiz-Cortés, E. González-Romera, R. Amaral-Lopes, E. Romero-Cadaval, J. Martins, M. I. Milanés-Montero, and F. Barrero-González, "Optimal charge/discharge scheduling of batteries in microgrids of prosumers," *IEEE Trans. Energy Convers.*, vol. 34, no. 1, pp. 468–477, Mar. 2019, doi: [10.1109/TEC.2018.2878351](https://doi.org/10.1109/TEC.2018.2878351).
- [40] S. Cui, Y.-W. Wang, J.-W. Xiao, and N. Liu, "A two-stage robust energy sharing management for prosumer microgrid," *IEEE Trans. Ind. Informat.*, vol. 15, no. 5, pp. 2741–2752, May 2019, doi: [10.1109/TII.2018.2867878](https://doi.org/10.1109/TII.2018.2867878).
- [41] M. Pourakbari-Kasmaei, M. Asensio, M. Lehtonen, and J. Contreras, "Trilateral planning model for integrated community energy systems and PV-based prosumers—A bilevel stochastic programming approach," *IEEE Trans. Power Syst.*, vol. 35, no. 1, pp. 346–361, Jan. 2020, doi: [10.1109/TPWRS.2019.2935840](https://doi.org/10.1109/TPWRS.2019.2935840).
- [42] *Directive (EU) 2019/944 OF The European Parliament and of the Council of 5 June 2019 on Common Rules for the Internal Market for Electricity and Amending Directive 2012/27/EU*. Accessed: May 26, 2020. <https://eur-lex.europa.eu/legal-content/EN/TXT/PDF/?uri=CELEX:32019L0944&from=EN>
- [43] *Energy Communities in Europe | A Reference Site for Aggregating Information About Energy Communities in Europe*. Accessed: May 27, 2020. [Online]. Available: <https://enercommunities.eu/>
- [44] N. Jenkins, C. Long, and J. Wu, "An overview of the smart grid in great britain," *Engineering*, vol. 1, no. 4, pp. 413–421, Dec. 2015, doi: [10.15302/J-ENG-2015112](https://doi.org/10.15302/J-ENG-2015112).
- [45] *Communication from the Commission to the European Parliament, the Council, the European Economic and Social Committee and the Committee of the Regions Delivering a New Deal for Energy Consumers COM(2015) 339 Final 2 Best Practices On Renewable Energy Self-Consumption*, Eur. Commission, Brussels, Belgium, 2015. [Online]. Available: https://ec.europa.eu/energy/sites/ener/files/documents/1_EN_ACT_part1_v8.pdf
- [46] *Balancing and Network Tariff Enginet*. Accessed: Jan. 4, 2021. [Online]. Available: <https://enginet.dk/EI/Elmarkedet/Tariffer>
- [47] M. Zugno, J. M. Morales, P. Pinson, and H. Madsen, "A bilevel model for electricity retailers' participation in a demand response market environment," *Energy Econ.*, vol. 36, pp. 182–197, Mar. 2013, doi: [10.1016/j.eneco.2012.12.010](https://doi.org/10.1016/j.eneco.2012.12.010).
- [48] H. Pandzic and V. Bobanac, "An accurate charging model of battery energy storage," *IEEE Trans. Power Syst.*, vol. 34, no. 2, pp. 1416–1426, Mar. 2019, doi: [10.1109/TPWRS.2018.2876466](https://doi.org/10.1109/TPWRS.2018.2876466).
- [49] *Orsted Dynamic Prices*. Accessed: May 26, 2020. [Online]. Available: <https://privat.orsted.dk/kundeservice/aftaler-og-priser/timepris/>
- [50] *Nord Pool Prices*. Accessed: May 26, 2020. [Online]. Available: <https://www.nordpoolgroup.com/>
- [51] *PVPC | ESIOS Electricity . Data . Transparency*. Accessed: Jan. 9, 2021. [Online]. Available: <https://www.esios.ree.es/en/pvpc>
- [52] *7H Kraft—Bygdens Batteri*. Accessed: Jan. 9, 2021. [Online]. Available: <https://www.7hkraft.se/>

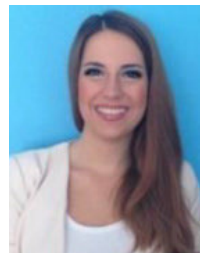

MIRNA GRŽANIĆ (Student Member, IEEE) received the Master of Science degree from the Faculty of Electrical Engineering and Computing, University of Zagreb, Zagreb, Croatia, in 2016, where she is currently pursuing the Ph.D. degree. Her research interests include power system optimization, electricity markets, and smart grids.



JUAN M. MORALES (Senior Member, IEEE) received the Ingeniero Industrial degree from the University Malaga, Malaga, Spain, in 2006, and the Ph.D. degree in electrical engineering from the University of Castilla-La Mancha, Ciudad Real, Spain, in 2010. He is currently an Associate Professor with the Department of Applied Mathematics, University of Malaga. His research interests include power systems economics, operations and planning, energy analytics and optimization, smart grids, decision-making under uncertainty, and electricity markets.



SALVADOR PINEDA (Member, IEEE) received the Ingeniero Industrial degree from the University of Malaga, Malaga, Spain, in 2006, and the Ph.D. degree in electrical engineering from the University of Castilla-La Mancha, Ciudad Real, Spain, in 2011. He is currently an Associate Professor with the University of Malaga. His research interests include power system operation and planning, electricity markets, renewable integration, energy policy, game theory, and optimization.



TOMISLAV CAPUDER (Member, IEEE) received the Master of Electrical Engineering and Ph.D. degrees from the Department of Energy and Power Systems, Faculty of Electrical Engineering and Computing, in 2008 and 2014, respectively. He is currently an Assistant Professor with the Department of Energy and Power Systems, Faculty of Electrical Engineering and Computing. His research interests include energy systems planning and modeling, integrated infrastructures, distributed energy systems, energy markets, and environmental protection in power systems.

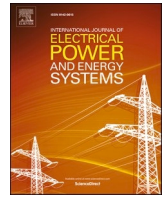

Coordinated scheduling of renewable energy balancing group

Mirna Gržanić, Tomislav Capuder*

Faculty of Electrical Engineering and Computing, University of Zagreb, Unska 3, 10 000 Zagreb, Croatia

ARTICLE INFO

Keywords:

Aggregator
Balancing groups
Coordinated operation
Energy storage
Flexibility

ABSTRACT

In the post incentives era, renewable energy sources (RES) need to become balancing responsible market participants. As their controllability is limited and questionably economically feasible, they will, mostly likely, join an existing balancing group or form a new one capable of flexible operation driven by market signals. In line with this, the paper proposes a novel concept of a new market balancing group, coordinating participation of a wind power plant and flexible sources presented by a single actor, the aggregator. The model is cast as a stochastic mixed integer linear programming (MILP) bilevel model where the upper level model is profit maximization of the new market balancing group, while the lower level problem models minimization of end user electricity cost. The two entities collaborate to reduce deviations from market schedules, where their mutual exchange occurs under zero cost. Individual and coordinated market participation are compared considering uncertainties of RES generation and market prices. The results show both cases; when coordinated participation creates financial benefits for both wind power plant and end-consumers, but also scenarios under which end-consumers will not consider offering their flexibility at the market through aggregators as they are better off not changing their supplier or tariff system. The latter case implies inadequate market incentives and products for universal inclusion of flexible end-users into active and price responsive system participation.

1. Introduction and motivation

As the share of renewable energy sources (RES) in power systems around the world increases, the concept of treating them as preferential producers, stimulated through feed-in tariff system and not responsible for increase the balancing requirements, is gradually being abandoned [1]. At the moment, in most European countries, responsibility for RES generation deviations from the announced schedule is passed on to the Transmission System Operator (TSO), while the balancing energy costs are charged to end-consumers through network fees. There are cases where RES are members of a balancing group (BG) (such as Croatian Energy Market Operator EKO balancing group aggregating all RES within the feed-in tariff system [2]) where the group leader focuses on accurate forecasting to reduce deviations from announced production. Opportunities for RES as market players have already been researched through either their individual participation [3], concepts of aggregators or virtual power plants [4] where a single entity represents a cluster of small units and takes on the role of a “smart” supplier, or through RES joining an existing BG. As a rule, these existing BG are composed of large generation units; for example, papers [5–9] present a coordination of wind power plant and large energy storage unit,

showing the benefits from joint operation, while authors of [10–13] focus of optimizing the coordination of wind and hydro power plant.

On the contrary, the latest energy package “Clean Energy for all Europeans” is putting focus on end prosumers and their market participation, particularly emphasizing the value of unlocking their flexibility [14]. Currently this end user flexibility refers to micro controllable generation units or demand response capabilities [15]. With decreasing prices of battery storage [16] and development of small scale battery system installations, additional opportunities arise on the prosumer side. Distributed flexibility of the prosumers contributes not only to their own market position but also to other less flexible RES. The idea behind the paper is to explore benefits of creating a new balancing group composed of RES only, where the aggregator of flexible end users is the BG leader. The aggregator would optimally plan the operation of the entire BG (by doing that it could increase its profit and profits of BG members) and due to higher financial benefits, the aggregator would be able to offer lower electricity cost to the end users.

The paper presents a stochastic mixed integer linear programming (MILP) bilevel model of a new balancing group whose members are wind power plant and active consumers represented by the aggregator. The balancing group participates in the day-ahead and the real-time market. To explore the benefits of such market participation, several

* Corresponding author.

E-mail addresses: mirna.grzanic@fer.hr (M. Gržanić), tomislav.capuder@fer.hr (T. Capuder).

Nomenclature**Sets**

$d \in D$ demand index
 $s \in S$ scenario index
 $t \in T$ time index

Continuous variables

$charging_{d,s,t}$ charging battery d in scenario s in time t
 $discharging_{d,s,t}$ discharging battery d in scenario s in time t
 $E_{d,s,t}$ electrical energy used in heat pump in household d in scenario s in time t
 $E_{s,t}^{DOWN}$ energy sold by an aggregator for down-regulation at the real time market in scenario s in time t
 $E_{s,t}^{UP}$ energy purchased by an aggregator for up-regulation at the real-time market in scenario s in time t
 $Import_{d,s,t}^{HD}$ energy imported from the market for demand d in scenario s in time t
 $P_{s,t}^{AtoW}$ total energy exported from an aggregator to wind power plant in scenario s in time t
 P_t^{WDA} wind power plant's contracted selling energy at day ahead market in time t
 $P_{d,s,t}^{AtoWDEMAND}$ energy exported from demand d to wind power plant in scenario s in time t
 P_t^{DA} aggregator's contracted energy at the day-ahead market in time t
 $P_{s,t}^{IMPORTTOTAL}$ total imported energy from market in scenario s in time t
 $P_{s,t}^{WtoA}$ total energy exchanged from wind power plant to aggregator in scenario s in time t
 $P_{d,s,t}^{WtoADEMAND}$ energy imported from wind power plant to demand d in scenario s in time t
 $P_{s,t}^{WNEW}$ production of wind power plant in scenario s in time t after energy exchange with prosumers
 $price_{d,s,t}^{CONSUMER}$ dynamic price of energy for consumer d in scenario s in time t
 $SOC_{d,s,t}$ state of charge of battery d in scenario s in time t
 $T_{d,t}^{room}$ room temperature in household d in scenario s in time t
 $Q_{d,s,t}$ thermal energy in household d in scenario s in time t
 $\Delta_{s,t}^+$ excess of energy in scenario s in time t , positive system imbalance
 $\Delta_{s,t}^-$ deficit of energy in scenario s in time t , negative system imbalance

Parameters

A_d surface area of household d exposed to the outside temperature
 bat maximum power capacity of battery
 c specific heat of air in the room
 COP coefficient of performance of a heat pump
 $HD_{d,s,t}$ demand consumption d in scenario s in time t
 m_d mass of the air in the household d
 $P_{s,t}^W$ wind power plant production in scenario s in time t
 $penal_{s,t}^{DOWN}$ down regulation penalty at the real-time market in scenario s in time t
 $penal_{s,t}^{UP}$ up regulation penalty at the real-time market in scenario s in time t
 $price^{AVERAGE}$ average dynamic price for consumers
 $price^{MAX}$ maximum dynamic price for consumers
 $price^{MIN}$ minimum dynamic price for consumers
 $price_{s,t}^{SPOT}$ day-ahead market price of energy in scenario s in time t
 $PV_{d,s,t}$ solar panel production of household d in scenario s in time t

 P_{max}^W

installed capacity of wind power plant

 $r_{s,t}^+$ indicator for positive net system imbalance in scenario s in time t if < 1 $r_{s,t}^-$ indicator for negative net system imbalance in scenario s in time t if greater than 1 SOC^{MAX}

energy capacity of battery

 $T_{d,t}^{min}$

minimum inside temperature set by prosumer

 $T_{d,t}^{max}$

maximum inside temperature set by prosumer

 U

U value of the surfaces exposed the outside temperature

 η

charging/discharging coefficient

 π_s probability of scenario s **Binary variables** $x_{d,s,t}^{AtoW}$ indicator for exported energy from household d to the wind power plant in scenario s in time t $x_{d,s,t}^{WtoA}$ indicator for imported energy in household d from the wind power plant in scenario s and time t **Dual variables** $\beta_{d,s,t}$ Dual variable associated with power balance of consumer d in scenario s and time t γ_s Dual variable associated with energy exchange balance between consumers and WPPP in scenario s $\vartheta_{d,s,t}^{CHMAX}$ Dual variable associated with maximum rate of battery charging d in scenario s and time t $\vartheta_{d,s,t}^{CHMIN}$ Dual variable associated with minimum rate of battery charging d in scenario s and time t $\vartheta_{d,s,t}^{DISMAX}$ Dual variable associated with maximum rate of battery discharging d in scenario s and time t $\vartheta_{d,s,t}^{DISMIN}$ Dual variable associated with minimum rate of battery discharging d in scenario s and time t $\vartheta_{d,s,t}^{SOCMAX}$ Dual variable associated with maximum rate of battery d SOC in scenario s and time t $\vartheta_{d,s,t}^{SOCMIN}$ Dual variable associated with minimum rate of battery d SOC in scenario s and time t $\mu_{d,s,t}^{IMPORTMAX}$ Dual variable associated with maximum import from the grid of consumer d in scenario s and time t $\mu_{d,s,t}^{IMPORTMIN}$ Dual variable associated with minimum import from the grid of consumer d in scenario s and time t $\varphi_{d,s,t}^{SOC}$ Dual variable associated with battery d SOC in scenario s and time t $\omega_{d,s,t}^{AtoWMAX}$ Dual variable associated with maximum rate of energy exchange from consumer d to WPP in scenario s and time t $\omega_{d,s,t}^{AtoWMIN}$ Dual variable associated with minimum rate of energy exchange from consumer d to WPP in scenario s and time t $\omega_{d,s,t}^{WtoAMAX}$ Dual variable associated with maximum rate of energy exchange from WPP to consumer d in scenario s and time t $\omega_{d,s,t}^{WtoAMIN}$ Dual variable associated with minimum rate of energy exchange from WPP to consumer d in scenario s and time t $\vartheta_{d,s,t}^{SOC_{d,0}}$ Dual variable associated with initial stage of battery d in scenario s and time 0 $\vartheta_{d,s,t}^{SOC_{d,24}}$ Dual variable associated with final stage of battery d in scenario s and time 24**Auxiliary variables** $P_{s,t}^{WNEW}$ Auxiliary variable related to wind production and energy exchange with consumers in scenario s and time t $\omega_{d,s,t}^{AtoW*}$

Auxiliary variable for linearization of product of binary and continuous variable associated with energy exchange

$\omega_{d,s,t}^{WtoA^*}$ between consumers and WPP
Auxiliary variable for linearization of product of binary
and continuous variable associated with energy exchange

between WPP and consumers
 $u_{d,s,t}^1 - u_{d,s,t}^{12}$ Auxiliary binary variables associated with Fortuny-
Amat Transformations linearization

approaches are compared. In the first instance the conventional supplier offering two-tariff price system to its consumers is compared to the aggregator offering dynamic pricing scheme reflecting market prices without energy exchange with wind power plant. These models are bilevel problems since the objective in the upper level problem is maximization of profit for the supplier/aggregator, while the objective of the lower level problem is minimization of electricity cost for the end-consumer. Bilevel modelling enables determining dynamic prices for end-consumers guided by the upper level and resulting in better solution for both levels.

The second step extends the previous model by introducing a new balancing group, where the aggregator and the wind power plant coordinate their energy exchange in order to maximize benefits. Again, in the second step, two cases are analysed. Following the logic that the end-users will sign the contract with the aggregator only if their electricity bills are reduced, the analysis deals with finding a preferential tariff for them. This is done by comparing the two-tariff price system with a dynamic pricing scheme. Stochasticity of RES production and end-user consumption is taken into account. The findings suggest that coordinated market participation gives the opportunity for aggregator to reduce his imbalance penalties caused by deviation from day-ahead schedule and for wind power plant to increase its profit. The rest of the paper is organized as follows: in Section 2 authors present literature review and contributions of the paper, Section 3 describes the mathematical model, while Extensive analysis of the results with comments and conclusions are shown in Section 4. Conclusion is highlighted in Section 5.

2. Literature review and contributions

The modelling inspired by the game-theoretic approach is widely used in consumers-supplier (aggregator) optimization models. The work in [17] proposes demand response through Stackelberg game with energy provider and final consumers interaction in 24-hours period resulting in different power consumption in real-time pricing mechanism compared to flat rate (lower consumption during the peak-hours). The results of Stackelberg game under uncertainty in [18] show how controlling residential demand response through dynamic prices program results in optimal consumption, creating financial benefits for energy provider. Authors in [19] present the model for consumer's behaviour based on prices set by utility companies and derived as Stackelberg game. A bilevel grid operator-consumers model in [20] uses Stackelberg game approach to define electricity tariffs to end-consumers stimulating them to follow the desired consumption profile and to reduce the difference between actual consumption and the target one. A Stackelberg leader-follower problem (microgrid operator-photovoltaic prosumers) in [21] maximizes both profits: that of the leader prosumer and of the follower utility through demand response program. The work in [22] is additionally expanded with the concept of PV prosumers sharing energy, setting the peer-to-peer trading price as the Stackelberg equilibrium with microgrid operator participating in day-ahead and real-time market. Heuristic algorithm in [23], based on game theory, presents energy management of microgrids with combined heat and power and PV active consumers. The authors present modelling of prices for the end consumers which are lower in case of microgrid operator selling electricity and higher when buying it, as compared to traditional prosumers-grid concept. The work in [24] describes how energy peer-to-peer trading with price-based (dynamic price scheme) demand response among prosumers with flexible load in the microgrid is more profitable than in case when they operate passively, relying on

feed-in tariffs. Similar results can be found in [25], also capturing uncertainties and participation in day-ahead and real-time markets. The model in [26] presents competition between utility companies through utility end-consumer Stackelberg game which maximizes utility companies' profit and guarantees the minimum budget for consumers electricity procurement. The authors in [27] describe energy management with real-time price demand response through leader-follower Stackelberg game resulting in decrease consumption during the periods of high prices. Work in [28] is based on Stackelberg game in which the aggregator of demand response sells energy discharged from the battery storage to other aggregators, while utility controls the price and quantity of sold electricity. The results show increased profit for those aggregators who use price-sensitive demand response. The authors in [29] define relations between utility company as a leader and generators as followers through Stackelberg game considering flat, real time and Stackelberg real time pricing resulting in higher profit in the two latter approaches. In the second stage of described model, end customers adjust their shiftable loads to minimize their costs under different dissatisfaction parameters.

The work in [30] presents a stochastic, bi-level, three-stage model of aggregator of flexible heating demand. The results show that dynamic pricing scheme increases the total aggregator's profit, however it also results in higher costs for end consumers. The idea presented in [30] serves as a backbone of the proposed research in this paper with some major differences. Our proposed model goes beyond aggregator only model and looks into hidden opportunities of different RES collaborating as one BG. We also introduce an energy exchange mechanism of this new balancing group of active consumers and a wind power plant, resulting in reduced penalties arisen from uncertainties in wind and solar production, as well as consumers' consumption. The result section brings an extensive analysis, where the analyses capture different scenarios and prosumer options, resulting in conclusions in which cases aggregation and dynamic prices make financial sense for flexible prosumers. Unlike [30], aggregators dynamic prices enable lower electricity procurement cost for certain installation sizes, when comparing them to today's supplier ToU scheme. This could, consequently, create opportunities for emergence of aggregators and further liberalization of the retail electricity market.

Following on the above, the paper presents the following contributions:

1. Mathematical model of the new balancing group composed of small scale prosumers and renewable energy sources. The model captures interaction of different BG members, as well as sharing flexibility resources, with the goal of creating financial benefits for all stakeholders;
2. Dynamic prices created by the aggregator can result in lower overall cost of electricity for end-users when compared to the traditional fixed tariff prices offered by suppliers. The results suggest that only prosumers with smaller installed PV capacity and production lower than overall consumption might be interested in switching from two-tariff ToU to dynamic aggregator pricing, as they financially benefit from doing so. On the other hand, the results suggest that prosumers with larger PV capacity installations are unlikely to be willing to switch to dynamic pricing schemes and direct market participation through aggregators;
3. Pricing mechanisms correlated with market prices results in lower benefit for the balancing group due to insufficient coordination of the prices and flexibility need.

3. Model description

The model considers two stages: day-ahead market and real-time market. The aggregator contracts electricity procurement at the day-ahead market for each hour of the upcoming day and sells (buys) the surplus (deficit) of electricity on real-time market. Ten scenarios are used to define uncertainty of wind power plant and PV production, market prices and consumption due to incomplete information on the day-ahead stage and possible deviations in predictions. As shown in [31], 10 scenarios are a good trade-off between computational complexity and cost performance. Day-ahead market prices are presented in Fig. 1, showing volatility between 0 €/MWh to 63 €/MWh during the day:

In the considered case the aggregator supplies 30 households. Total PV production and demand of households represented by the aggregator are shown in Figs. 2a and 2b, distinguishing two different installed PV capacity [32]. Blue lines present different consumption scenarios, while the red lines present different PV production scenarios. Each household is equipped with a battery storage unit, installed for arbitrage purpose. Battery is empty at the beginning and at the end of the day, while maximum charging and discharging are limited to 3.4 kW. Battery capacity is 4 kWh [33]. Discharging coefficient η_{dis} is 0.97, while the charging coefficient η_{ch} is 0.98.

Wind power plant sells electricity at the day-ahead market, while at real-time market is paid or charged for the deviation (depends if it contributes to or harms the electricity balance). Installed capacity of wind power plant is 200 kW and production is shown in Fig. 3.

The focus in the paper is on the mathematical model of the new balancing group and the market clearing is not considered; the proposed balancing group is considered as a price-taker.

3.1. Aggregator and wind power plant profit maximization

The objective of the upper-level problem is profit maximization for both the aggregator and the wind power plant (1):

$$\begin{aligned} & \max \pi_s \sum_{d \in D} \sum_{s \in S} \sum_{t \in T} price_{d,s,t}^{CONSUMER} \cdot Import_{d,s,t}^{HD} \\ & - \sum_{s \in S} \sum_{t \in T} (penal_{s,t}^{UP} \cdot E_{s,t}^{UP} + penal_{s,t}^{DOWN} \cdot E_{s,t}^{DOWN}) \\ & + price_{s,t}^{SPOT} \cdot p_{s,t}^{IMPORT_{TOTAL}} \\ & + \sum_{s \in S} \sum_{t \in T} price_{s,t}^{SPOT} \cdot (P_t^{WDA} + r_{s,t}^+ \cdot \Delta_{s,t}^+ - r_{s,t}^- \cdot \Delta_{s,t}^-) \end{aligned} \quad (1)$$

The first term in objective function presents profit from selling the electricity to the end-consumers. The aggregator creates dynamic prices for its users, making this a decision variable for every consumer d . The second and the third term describe penalties due to aggregator

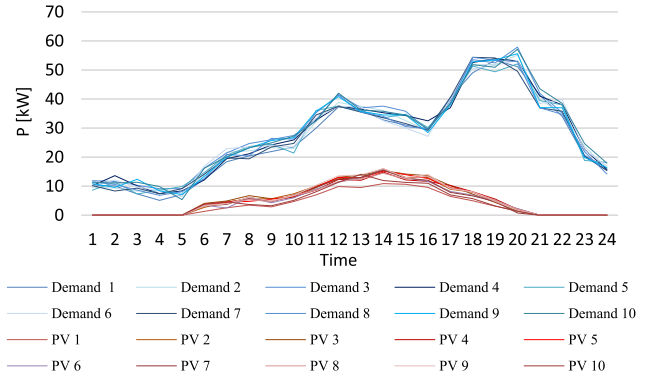

Fig. 2a. Scenarios of total consumption and low PV production.

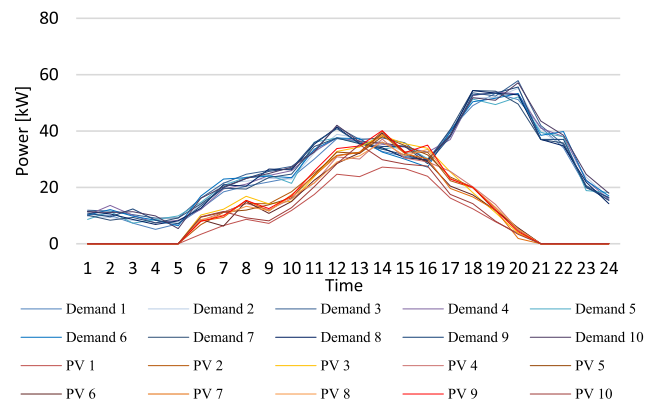

Fig. 2b. Scenarios of total consumption and large PV production.

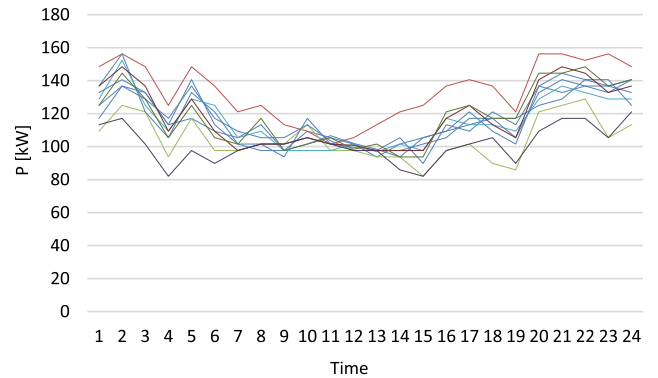

Fig. 3. Scenarios of wind production.

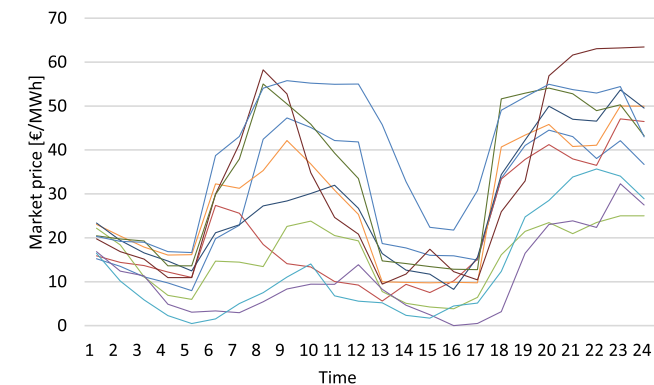

Fig. 1. Day-ahead prices.

imbalance and unperfect information of consumers' consumption and solar production; this is defined similar as in [30]. The fourth term describes aggregator's cost for purchasing electricity at the market. The last term is wind power plant profit derived from [34]. It should be noted that in systems with dominant RES production it is likely that the markets and market products will be defined differently, meaning that the above defined objective function incorporating penalties for deviations might not hold in future system scenarios with high shares of variable and uncertain production. The penalties defined in (1) reflect balancing prices. The deviation is penalized only if it is in the opposite direction of the system need, as explained in [30]. If the deviation is in the same direction as the system need, it is not rewarded, the energy is traded at the day-ahead price.

Total electricity purchased at the market in scenario s and time t is equal to the sum of electricity bought at the market for all active

consumers d (2):

$$P_{s,t}^{IMPORT_{TOTAL}} = \sum_{d \in D} Import_{d,s,t}^{HD}, \forall s, \forall t \quad (2)$$

Electricity purchased and sold at the real-time market for up and down regulation is modelled with (3) and (4).

$$E_{s,t}^{UP} \geq P_{s,t}^{IMPORT_{TOTAL}} - P_T^{DA} \quad (3)$$

$$E_{s,t}^{DOWN} \geq P_T^{DA} - P_{s,t}^{IMPORT_{TOTAL}} \quad (4)$$

Deviations from contracted energy at the day ahead market for wind power plant are described with (5)–(7):

$$\Delta_{s,t}^+ - \Delta_{s,t}^- = P_{s,t}^{W_{NEW}} - P_t^{W_{DA}} \quad (5)$$

$$P_{s,t}^{W_{NEW}} = P_{s,t}^W + P_{s,t}^{AtoW} - P_{s,t}^{WtoA} \quad (6)$$

$$P_{s,t}^{W_{NEW}}, \Delta_{s,t}^+, \Delta_{s,t}^- \leq P_{max}^W \quad (7)$$

Energy exchange between active consumers and the wind power plant is defined with (8) and (9). Total energy exported from the aggregator to the wind power plant is set to be equal to the sum of energy exported from each active consumer d (8), while total energy imported from wind power plant is the sum of imported energy to each active consumer d (9). Total energy exchange is limited with battery power capacity for every scenario s and time t (10) and (11):

$$P_{s,t}^{AtoW} = \sum_{d \in D} P_{d,s,t}^{AtoW_{DEMAND}} \quad (8)$$

$$P_{s,t}^{WtoA} = \sum_{d \in D} P_{d,s,t}^{WtoA_{DEMAND}} \quad (9)$$

$$P_{d,s,t}^{AtoW} \leq D \cdot bat \quad (10)$$

$$P_{d,s,t}^{WtoA} \leq D \cdot bat \quad (11)$$

Energy exchange between active consumer d and wind power plant is only possible in one direction (12):

$$x_{d,s,t}^{AtoW} + x_{d,s,t}^{WtoA} \leq 1 \quad (12)$$

Dynamic prices for active consumers are defined to be higher than minimal predefined value (13) and lower than maximal predefined value (14), satisfying the daily average price (15).

$$price_{d,s,t}^{CONSUMER} \geq price^{MIN} \quad (13)$$

$$price_{d,s,t}^{CONSUMER} \leq price^{MAX} \quad (14)$$

$$\sum_{t \in T} price_{d,s,t}^{CONSUMER} = price^{AVERAGE} \quad (15)$$

3.2. End-consumers cost minimization**

The lower-level problem minimizes the consumers' cost for electricity procurement (16) from aggregator. Consumers' prices are limited between $price^{MIN}$ and $price^{MAX}$ (125.2 and 159.3 €/MWh), while the average daily price $price^{AVERAGE}$ is 142.25 €/MWh [35].

Dual variables for each equation are listed after semicolon.

$$\min \pi_s \sum_{d \in D} \sum_{s \in S} \sum_{t \in T} (price_{d,s,t}^{CONSUMER} \cdot Import_{d,s,t}^{HD}) \quad (16)$$

The power balance is presented with (17):

$$HD_{d,s,t} + charging_{d,s,t} + P_{d,s,t}^{AtoW_{DEMAND}} =$$

$$Import_{d,s,t}^{HD} + discharging_{d,s,t} + P_{d,s,t}^{WtoA_{DEMAND}}$$

$$+ PV_{d,s,t} : \beta_{d,s,t} \quad (17)$$

Battery d state of charge (SOC) is described with (18):

$$SOC_{d,s,t} = SOC_{d,s,t-1} + \eta_{ch} \cdot charging_{d,s,t}$$

$$- \frac{discharging_{d,s,t}}{\eta_{dis}} : \varphi_{d,s,t}^{SOC} \quad (18)$$

Total sum of imported energy from wind power plant during the day is equal to the total exported energy from each active consumer d (19):

$$\sum_{d \in D} \sum_{t \in T} P_{d,s,t}^{AtoW_{DEMAND}} = \sum_{d \in D} \sum_{t \in T} P_{d,s,t}^{WtoA_{DEMAND}} : \gamma_s \quad (19)$$

Battery charging and discharging are limited with (20)–(23), while SOC is limited with battery energy capacity (24) and (25), and (26) and (27) present SOC at the beginning and the end of the day:

$$charging_{d,s,t} \geq 0 : \vartheta_{d,s,t}^{CH_{MIN}} \quad (20)$$

$$discharging_{d,s,t} \geq 0 : \vartheta_{d,s,t}^{DIS_{MIN}} \quad (21)$$

$$charging_{d,s,t} \leq bat : \vartheta_{d,s,t}^{CH_{MAX}} \quad (22)$$

$$discharging_{d,s,t} \leq bat : \vartheta_{d,s,t}^{DIS_{MAX}} \quad (23)$$

$$SOC_{d,s,t} \geq 0 : \vartheta_{d,s,t}^{SOC_{MIN}} \quad (24)$$

$$SOC_{d,s,t} \leq SOC^{MAX} : \vartheta_{d,s,t}^{SOC_{MAX}} \quad (25)$$

$$SOC_{d,s,0} = SOC_{initial} : \vartheta_{d,s,0}^{SOC_{initial}} \quad (26)$$

$$SOC_{d,s,24} = SOC_{initial} : \vartheta_{d,s,24}^{SOC_{end}} \quad (27)$$

Energy bought at the market in scenario s and time t is greater than zero and limited with sum of battery power capacity and active consumer's d consumption in scenario s and time t (28) and (29):

$$Import_{d,s,t}^{HD} \geq 0 : \mu_{d,s,t}^{IMPORT_{MIN}} \quad (28)$$

$$Import_{d,s,t}^{HD} \leq P_d^{rated} : \mu_{d,s,t}^{IMPORT_{MAX}} \quad (29)$$

Energy exchange between active consumer d and wind power plant is limited with battery power capacity (30)–(33):

$$P_{d,s,t}^{AtoW_{DEMAND}} \geq 0 : \omega_{d,s,t}^{AtoW_{MIN}} \quad (30)$$

$$P_{d,s,t}^{AtoW_{DEMAND}} \leq bat \cdot x_{d,s,t}^{AtoW} : \omega_{d,s,t}^{AtoW_{MAX}} \quad (31)$$

$$P_{d,s,t}^{WtoA_{DEMAND}} \geq 0 : \omega_{d,s,t}^{WtoA_{MIN}} \quad (32)$$

$$P_{d,s,t}^{WtoA_{DEMAND}} \leq bat \cdot x_{d,s,t}^{WtoA} : \omega_{d,s,t}^{WtoA_{MAX}} \quad (33)$$

3.3. KKT formulation of end-consumer problem

KKT formulation of the lower-level problem is defined with lower level equations (16)–(33) and stationarity conditions (34)–(42), as well as with complementary slackness conditions associated with the inequality constraints (43)–(54):

$$\vartheta_{d,s,t}^{CH_{MAX}}, \vartheta_{d,s,t}^{DIS_{MAX}}, \vartheta_{d,s,t}^{SOC_{MAX}}, \mu_{d,s,t}^{IMPORT_{MAX}}, \vartheta_{d,s,t}^{CH_{MIN}},$$

$$\vartheta_{d,s,t}^{DIS_{MIN}}, \vartheta_{d,s,t}^{SOC_{MIN}}, \mu_{d,s,t}^{IMPORT_{MIN}},$$

$$\omega_{d,s,t}^{AtoW_{MIN}}, \omega_{d,s,t}^{WtoA_{MIN}}, \omega_{d,s,t}^{AtoW_{MAX}}, \omega_{d,s,t}^{WtoA_{MAX}} \geq 0 \quad (34)$$

$$\varphi_{d,s,t}^{SOC} - \vartheta_{d,s,0}^{SOC_{initial}} = 0 \quad (35)$$

$$-\varphi_{d,s,t}^{SOC} + \varphi_{d,s,t+1}^{SOC} + \vartheta_{d,s,t}^{SOC_{MIN}} - \vartheta_{d,s,t}^{SOC_{MAX}} = 0, \forall t[1, 23] \quad (36)$$

$$-\varphi_{d,s,24}^{SOC} - \vartheta_{d,s,0}^{SOC_{end}} = 0 \quad (37)$$

$$-\beta_{d,s,t} + \mu_{d,s,t}^{IMPORT_{MIN}} - \mu_{d,s,t}^{IMPORT_{MAX}} = price_{d,s,t}^{CONSUMER} \quad (38)$$

$$-\beta_{d,s,t} + \omega_{d,s,t}^{WtoA_{MIN}} - \omega_{d,s,t}^{WtoA_{MAX}} - \gamma_s = 0 \quad (39)$$

$$\beta_{d,s,t} + \omega_{d,s,t}^{AtoW_{MIN}} - \omega_{d,s,t}^{AtoW_{MAX}} + \gamma_s = 0 \quad (40)$$

$$\frac{\varphi_{d,s,t}^{SOC}}{\eta} + \vartheta_{d,s,t}^{DIS_{MIN}} - \vartheta_{d,s,t}^{DIS_{MAX}} - \beta_{d,s,t} = 0 \quad (41)$$

$$\eta \cdot \varphi_{d,s,t}^{SOC} + \vartheta_{d,s,t}^{CH_{MIN}} - \vartheta_{d,s,t}^{CH_{MAX}} + \beta_{d,s,t} = 0 \quad (42)$$

$$charging_{d,s,t} \geq 0 \perp \vartheta_{d,s,t}^{CH_{MIN}} \geq 0 \quad (43)$$

$$discharging_{d,s,t} \geq 0 \perp \vartheta_{d,s,t}^{DIS_{MIN}} \geq 0 \quad (44)$$

$$SOC_{d,s,t} \geq 0 \perp \vartheta_{d,s,t}^{SOC_{MIN}} \geq 0 \quad (45)$$

$$bat - charging_{d,s,t} \geq 0 \perp \vartheta_{d,s,t}^{CH_{MAX}} \geq 0 \quad (46)$$

$$bat - discharging_{d,s,t} \geq 0 \perp \vartheta_{d,s,t}^{DIS_{MAX}} \geq 0 \quad (47)$$

$$SOC^{MAX} - SOC_{d,s,t} \geq 0 \perp \vartheta_{d,s,t}^{SOC_{MAX}} \geq 0 \quad (48)$$

$$Import_{d,s,t}^{HD} \geq 0 \perp \mu_{d,s,t}^{IMPORT_{MIN}} \geq 0 \quad (49)$$

$$HD_{d,s,t} + bat - Import_{d,s,t}^{HD} \geq 0 \perp \mu_{d,s,t}^{IMPORT_{MAX}} \geq 0 \quad (50)$$

$$P_{d,s,t}^{AtoW_{DEMAND}} \geq 0 \perp \omega_{d,s,t}^{AtoW_{MIN}} \geq 0 \quad (51)$$

$$bat \cdot x_{d,s,t}^{AtoW} - P_{d,s,t}^{AtoW_{DEMAND}} \geq 0 \perp \omega_{d,s,t}^{AtoW_{MAX}} \geq 0 \quad (52)$$

$$P_{d,s,t}^{WtoA_{DEMAND}} \geq 0 \perp \omega_{d,s,t}^{WtoA_{MIN}} \geq 0 \quad (53)$$

$$P_{s,t}^{WtoA} \cdot x_{d,s,t}^{WtoA} - P_{d,s,t}^{WtoA_{DEMAND}} \geq 0 \perp \omega_{d,s,t}^{WtoA_{MAX}} \geq 0 \quad (54)$$

Note that equations (43)–(54) are not linear and Fortuny-Amat Transformations are used for linearization [36]. The example is shown for condition (43) and it is applied on (44)–(54) where M presents a sufficiently large constant and variables $u_{d,s,t}^x$ are auxiliary binary variables used for linearization:

$$charging_{d,s,t} \leq M \cdot u_{d,s,t}^1$$

$$\vartheta_{d,s,t}^{CH_{MIN}} \leq M \cdot (1 - u_{d,s,t}^1) \quad (55)$$

3.4. Bilevel formulation

First term in the objective function (1) is non-linear and thus is replaced with (56) from strong-duality theorem:

$$\max \pi_s - \sum_{d \in D} \sum_{s \in S} \sum_{t \in T} [\beta_{d,s,t} \cdot (HD_{d,s,t} - PV_{d,s,t})$$

$$+ bat \cdot (\vartheta_{d,s,t}^{CH_{MAX}} + \vartheta_{d,s,t}^{DIS_{MAX}}) + bat \cdot x_{d,s,t}^{AtoW} \cdot \omega_{d,s,t}^{AtoW} +$$

$$bat \cdot x_{d,s,t}^{WtoA} \cdot \omega_{d,s,t}^{WtoA} + (P_d^{rated}) \cdot \mu_{d,s,t}^{IMPORT_{MAX}}]$$

$$- \sum_{d \in D} \sum_{s \in S} \sum_{t \in T/24} (SOC^{MAX} \cdot \vartheta_{d,s,t}^{SOC_{MAX}})$$

$$- \sum_{d \in D} \sum_{s \in S} SOC^{initial} \cdot (\vartheta_{d,s,0}^{SOC_{initial}} + \vartheta_{d,s,24}^{SOC_{end}})$$

$$- \sum_{s \in S} \sum_{t \in T} (penal_{s,t}^{UP} \cdot E_{s,t}^{UP} + penal_{s,t}^{DOWN} \cdot E_{s,t}^{DOWN}$$

$$+ price_{s,t}^{SPOT} \cdot P_{s,t}^{IMPORT_{TOTAL}})$$

$$+ \sum_{s \in S} \sum_{t \in T} price_{d,s,t}^{SPOT} \cdot (P_t^{W_{DA}} + r_{s,t}^+ \cdot \Delta_{s,t}^+ - r_{s,t}^- \cdot \Delta_{s,t}^-) \quad (56)$$

Objective function (56) is non-linear due to product of binary and continuous variable. Auxiliary variables $\omega_{d,s,t}^{AtoW^*}$ and $\omega_{d,s,t}^{WtoA^*}$ are added for linearization purposes and the objective function is finally defined as (57) with additional constraints (58)–(63) used for linearization:

$$\max \pi_s - \sum_{d \in D} \sum_{s \in S} \sum_{t \in T} [\beta_{d,s,t} \cdot (HD_{d,s,t} - PV_{d,s,t})$$

$$+ bat \cdot (\vartheta_{d,s,t}^{CH_{MAX}} + \vartheta_{d,s,t}^{DIS_{MAX}}) + bat \cdot (\omega_{d,s,t}^{AtoW^*} +$$

$$\omega_{d,s,t}^{WtoA^*}) + (HD_{d,s,t} + bat) \cdot \mu_{d,s,t}^{IMPORT_{MAX}}]$$

$$- \sum_{d \in D} \sum_{s \in S} \sum_{t \in T/24} (SOC^{MAX} \cdot \vartheta_{d,s,t}^{SOC_{MAX}})$$

$$- \sum_{d \in D} \sum_{s \in S} SOC^{initial} \cdot (\vartheta_{d,s,0}^{SOC_{initial}} + \vartheta_{d,s,24}^{SOC_{end}})$$

$$- \sum_{s \in S} \sum_{t \in T} (penal_{s,t}^{UP} \cdot E_{s,t}^{UP} + penal_{s,t}^{DOWN} \cdot E_{s,t}^{DOWN}$$

$$+ price_{s,t}^{SPOT} \cdot P_{s,t}^{IMPORT_{TOTAL}})$$

$$+ \sum_{s \in S} \sum_{t \in T} price_{d,s,t}^{SPOT} \cdot (P_t^{W_{DA}} + r_{s,t}^+ \cdot \Delta_{s,t}^+ - r_{s,t}^- \cdot \Delta_{s,t}^-) \quad (57)$$

$$\omega_{d,s,t}^{AtoW^*} \leq x_{d,s,t}^{AtoW} \cdot M \quad (58)$$

$$\omega_{d,s,t}^{AtoW^*} \leq \omega_{d,s,t}^{AtoW} \quad (59)$$

$$\omega_{d,s,t}^{AtoW^*} \geq \omega_{d,s,t}^{AtoW} - (1 - x_{d,s,t}^{AtoW}) \cdot M \quad (60)$$

$$\omega_{d,s,t}^{WtoA^*} \leq x_{d,s,t}^{WtoA} \cdot M \quad (61)$$

$$\omega_{d,s,t}^{WtoA^*} \leq \omega_{d,s,t}^{WtoA} \quad (62)$$

$$\omega_{d,s,t}^{WtoA^*} \geq \omega_{d,s,t}^{WtoA} - (1 - x_{d,s,t}^{WtoA}) \cdot M \quad (63)$$

4. Results and analyses

This Section compares and analyses results of the following: (i) individual and coordinated market participation of a wind power plant and an aggregator of active consumers; (ii) benefits and disadvantages of different pricing scheme:

- Case 1: Traditional pricing system with two tariffs is taken as a benchmark where end consumers pay higher rates during the day (8–22 h) and lower during the night (22–8 h). In this case we do not consider possibilities of dynamic price scheme or coordination with other entities (e.g. wind power plant). Notice that this reflects the situation how it is today for the final consumers.
- Case 2: Unlike traditional pricing system with two fixed tariffs, the aggregator offers dynamic prices to end-consumers aiming to reduce their electricity bill as described in 3.2.

- Case 3: The aggregator and the wind power plant form a balancing group under the pricing explained in Case 2. The idea behind the coordinated approach is that the possibility of energy exchange between the active consumers and wind power plant enables selling more energy during peak-hours with higher prices, resulting in higher profit for wind power plant and reducing the penalties for aggregator.

The results are shown in Table 1 for low installed PV capacity and in Table 2 for larger PV capacity. Interestingly, creating dynamic prices by the aggregator for lower PV capacity installations on prosumers' rooftops results in lower electricity bills for end consumers, also increasing profit for the aggregator when compared to either individual market participation of the aggregator with two-tariff system (see Table 1). This implies that to those users it could be interesting to sign a contract with a dynamic price scheme and leave their traditional supplier. Table 1 and 2 present the situation in which all prosumers have the battery storage, while detail discussion with different percentage of prosumers equipped with battery storage and flexible thermal heating will be described further in the text.

On the other hand, as it can be seen from Table 2, in case of larger installed PV capacity the dynamic price scheme is not profitable for end-consumers, meaning that it is highly unlikely that end users with such installations will be willing to switch their current supplier. One could argue that the increased profit of the aggregator in Case 3 could be reduced to the value of supplier's profit in Case 1, and that difference used to reduce consumers costs of electricity. However, even in that case the consumers will not benefit from lower prices in Case 3 than they are in Case 1 (the Consumers cost of electricity would be equal for both cases).

In fact, their costs are even higher in the scenarios with coordinated participation in RES BG. This means that in cases where PV production is sufficient to cover the users' electricity needs during periods of higher tariff, the user might not be interested in switching to dynamic pricing and helping the rest of the system (since market prices reflect surplus of additional need for electricity), but will rather focus on being electricity self-sufficient. Potentially, this also means that these prosumers could additionally reduce their bills by selling electricity to end users with smaller or no PV capacity during periods of high market prices. Although this is an interesting conclusion, this case will not be further analysed as it is less interesting from the perspective of the new BG and will be the focus in future papers. Interestingly, end-consumer cost is slightly higher in Case 3 comparing to Case 2, but still lower than in Case 1. This means that the profit of the whole balancing group is higher, and end-consumers can be reimbursed for this difference. Reimbursement mechanism is out of the scope of this paper and it will be analysed in future work.

As the wind power plant profit was omitted from the Table 1, we briefly describe it in the text. In the individual operation scenario, the profit of the wind power plant is 70.79 €, while in coordinated option (lower end-user PV capacity) with aggregators dynamic pricing system it increases to 75.19 € (increase of 6.22%).

In Case 2 in Table 2, penalties and market cost are lower compared to Case 1 (which is a somewhat expected result). This can best be seen in Fig. 4 during the second prices valley (hours 15 and 16), when the aggregator schedules more purchased energy than the supplier. Aggregator's dynamic prices in Case 2 incentivize the consumers to consume more during the low-price period from hours 15 to 16 enabling them

Table 1
Cost and Profit-Low PV capacity/production.

	Case 1 €	Case 2 €	Case 3 €
Total profit	67.35	69.38	67.58
Penalties	0.58	0.28	0.14
Consumers cost of electricity	79.72	78.96	79.19

Table 2
Cost and Profit-Larger PV capacity/production.

	Case 1 €	Case 2 €	Case 3 €
Total profit	43.02	46.5	44.70
Penalties	0.92	0.44	0.24
Consumers cost of electricity	52.05	53.65	53.73

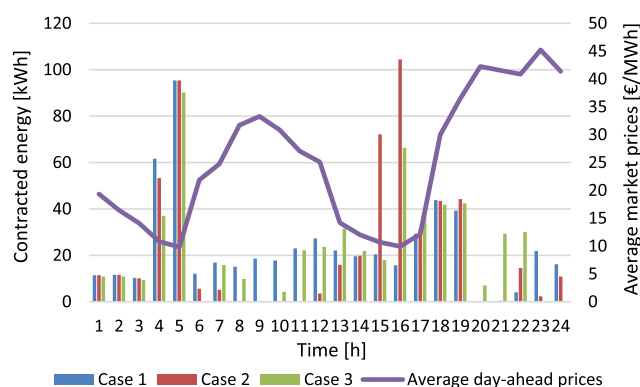

Fig. 4. Contracted energy on a day-ahead market.

lower cost than in Case 1. During the first price peak in the morning, from hours 7 to 12, aggregator contracts less in hours 7, 11 and 12 than in Case 1, while from hours 8 to 10 it does not contract energy at day-ahead market at all.

During high market prices in the morning, end-consumers are supplied from their battery storage units. During periods of low prices, wind power plant stores electricity in those batteries or supplies end-users demand. As it can be seen from Fig. 4 (green bars) during hours 4 and 5, the aggregator in Case 3 contracts less energy on a day-ahead market, compared to both Case 1 and Case 2, since it imports electricity from wind power plant in all scenarios (this can be seen in Fig. 5). The exception occurs only in scenarios when the wholesales market prices are close to 0. Similar pattern can be noticed also during the second period of low prices; in hours 15 and 16, the aggregator in Case 3 imports electricity from the wind power plant in scenarios of low market prices, while it exports it back to the wind power plant in high price scenarios. This means that the aggregator strategically uses end consumers battery units to store electricity from the wind power plant instead of buying expensive electricity from the wholesales market. This flexibility is also used for storing electricity during cheaper market price periods. An example can be seen during the second price peak period, where the aggregator chooses to store electricity bought at the market during hours 20 to 22 (lower price) and then discharges the batteries and sells it during hours 23 and 24 when the prices are the highest in the day.

In Fig. 5 the sum of electricity imported from wind power plant to

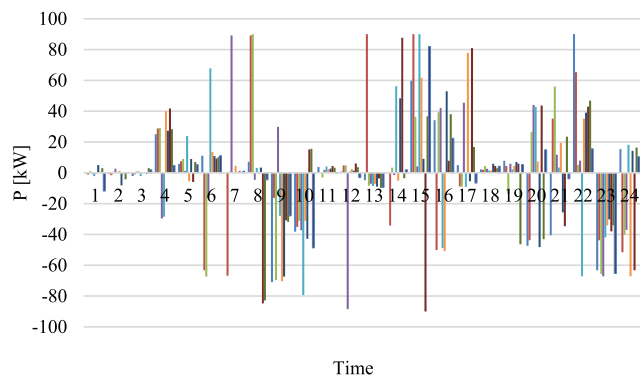

Fig. 5. Imported (positive values) and exported (negative values) electricity.

households is positive, while negative values present electricity exported back from the aggregator to the wind power plant. Households are supplied from batteries during hours 23 and 24 and battery is sufficient enough for electricity export as well.

Figs. 6–8 compare average of end-consumers’ battery charging and discharging for all analysed cases: two-tariff pricing in Case 1, dynamic price scheme in Case 2 and coordinated approach with wind power plant in Case 3. As it can be seen from the Fig. 7 in Case 1, the user battery is charged only once a day during early morning hours (low tariff) and discharged during the period of high tariff in the evening from hours 19 to 23.

In Case 2 in Fig. 7, the end user battery is firstly being charged during the early morning hours and then during hours 15 and 16, when the aggregator provides lower price to end-consumers due to lower market prices. During the market price peak in the morning and in the evening, the aggregator charges end-consumers higher price which results in supplying demand with battery discharging.

Batteries charging and discharging in Fig. 8 result in energy exchange between end-consumers and wind power plant. If compared to Figs. 4 and 5, batteries are discharged during the periods of high prices and energy is exported to wind power plant which enables wind power plant to gain more profit. During the periods of low prices, batteries are charged with imported energy from wind power plant and market.

Since the battery storage is not the only source of flexibility for final consumer, additional simulations are run with prosumers who have thermostatically controlled loads modelled as a heat pump. The heat pump is a device that transfers heat energy from a source of heat to a thermal reservoir. The coefficient of performance (COP) is a ratio of useful heat produced by the heat pump and the input energy. In our paper we used simplified model of the required heat energy from the heat pump to achieve the desired temperature in the household. Thermal energy for household heating is equal to the energy required for the temperature increase in time t according to the previous time period $t-1$ incurred by thermal losses due to the temperature difference between the room and outside temperature (64). Mass of the heated air in the household is calculated as the volume of the household multiplied with the density of air. The volume of a household is equal to the surface area of the household multiplied with a ceiling height. For the sake of simplicity, we modeled the surface area exposed the outside temperature as one surface with the same U value (we did not distinguish walls, windows, and doors and their belonging U values). Normally, U value is a measure of insulation of specific material and thus different materials (brick, wood, glass) have the different U value. We acknowledge that a detailed model could give more precise results, however we believe they would not significantly change the conclusions as compared to ours.

Thermal energy household heating is equal to the energy required for the temperature increase in time t according to the previous time period $t-1$ incurred by thermal losses due to the temperature difference between the room and outside temperature (64).

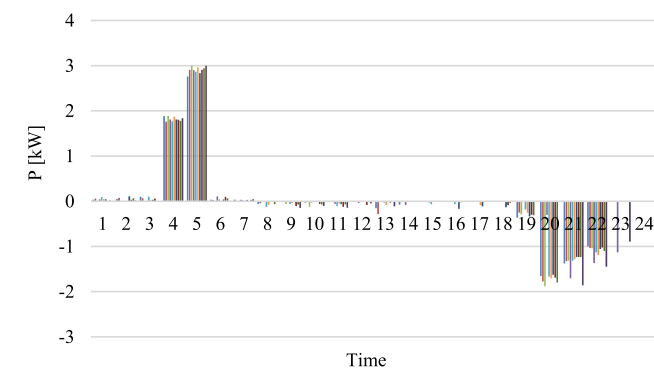

Fig. 6. End-users battery charging/discharging in Case 1.

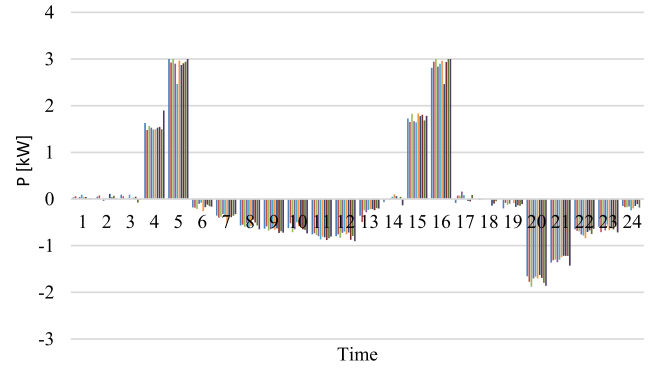

Fig. 7. End-users battery charging/discharging Case 2.

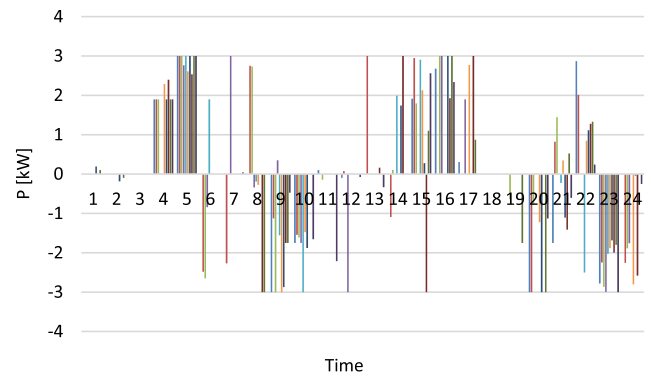

Fig. 8. End-users battery charging/discharging Case 3.

$$Q_{d,s,t} = c \cdot m_d \cdot (T_{d,s,t}^{room} - T_{d,s,t-1}^{room}) + A_d \cdot U \cdot (T_{d,s,t}^{room} - T_{s,t}^{atm}) \quad (64)$$

COP defines the ratio between thermal and electrical energy (65):

$$COP = \frac{Q_{d,s,t}}{E_{d,s,t}} \quad (65)$$

The temperature inside the household is between the bounds set by the prosumer (66) and (67):

$$T_{d,s,t}^{room} \geq T_{d,t}^{min} \quad (66)$$

$$T_{d,s,t}^{room} \leq T_{d,t}^{max} \quad (67)$$

The results of simulations in Table 3 present the cost the balancing group in which every household equipped with flexible thermal heating, while different percentage of prosumers have the battery onsite. In the first scenario 7 out of 30 (25%) prosumers are equipped with battery storage, in the second scenario 15 prosumers (50%), while in the third scenario 22 prosumers have the batteries onsite (75%).

As one can notice, total consumer’s cost and market cost is decreasing when more prosumers have battery onsite. Table 3 presents the total cost for consumers. Furthermore, this cost reduction is very small and to understand if additional benefits can be gained, several

Table 3 Results for different number of prosumers equipped with battery storage.

No. of batteries	7		15		22	
	Case 1	Case 2	Case 1	Case 2	Case 1	Case 2
Consumer’s cost	119.44	117.32	117.82	116.39	116.47	115.61
Penalties	0.82	1.23	0.82	0.99	0.82	0.76
Aggregator’s profit	97.03	95.69	96.69	96.93	96.44	98.01

additional simulations are performed in which prosumers prices are more dynamic. Here we define a Case 4 in which we introduce a simplified method of calculating costs for consumers, correlating their prices with the value of market price in scenario s and time t and calculated as (68):

$$price_{d,s,t}^{CONSUMER} = \lambda \hat{A} \cdot price_{s,t}^{SPOT} \quad (68)$$

Scaling factor λ is greater than 1. The aggregator sells the energy to final prosumers at the price higher than bought on the market.

We run several simulations with different value of scaling factor λ .

Furthermore, we wanted to demonstrate how the temperature difference between lower and upper temperature bound set by prosumer considering their comfort preferences effect the temperature in the household and consumed energy under different pricing mechanisms described in the paper. Pricing for prosumer 1 in one scenario is shown in Fig. 9 to demonstrate the difference between the pricing schemes.

We compared the results in non-flexible and flexible mode: in the non-flexible mode the inside temperature is fixed at the lower bound and in the flexible mode the difference between lower and upper temperature is 5 °C. In Case 1 and Case 2 under the pricing mechanism described in the beginning of Section 4, there is no difference in consumed energy for thermal heating in flexible and non-flexible regime. Pricing mechanisms in Case 1 and Case 2 explained in the paper are less dynamic than market prices and shifting the load does not affect the consumer’s profit. The energy consumed in each hour satisfies the lower temperature bound. On the other hand, if the prosumer is exposed to the prices correlated with the market prices as in Case 4a, the difference between the consumed energy is shown in Fig. 10:

HD_th_fix is the consumed energy for thermal heating when the price is set at the lower bound, while HD_th_flexi when prosumers sets the different lower and upper temperature bound. As one can notice in the Fig. 10, in the hour 5 prosumer with flexible temperature preheats the room before the price peak in hour 6. Moreover, the same situation occurs in the hour 17 and hour 18.

The aggregated results for different value of λ in Case 4 are shown in Table 4.

- Case 4a: λ is equal to 5.
- Case 4b: if the market price is higher than the average market price, λ is equal to 8, and if the market price is lower than average market price, λ is equal to 5.

As one can notice from Table 4, increasing the number of prosumers equipped with battery storage results in total consumer’s cost reduction by almost 20% when consumers are exposed to the dynamic market prices in Case 4a. Moreover, aggregator’s cost on the market is decreasing and penalties are increasing. General conclusions can be made for both scenarios of Case 4:

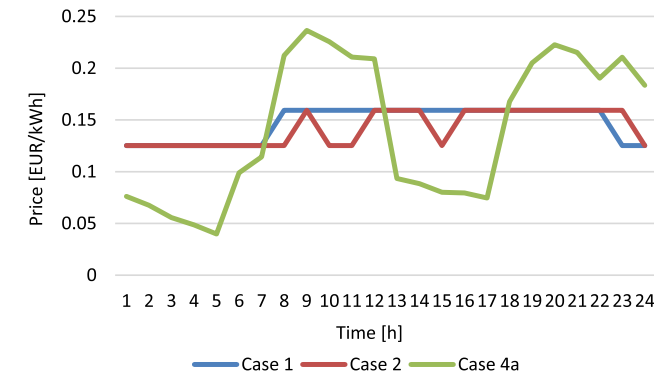

Fig. 9. Pricing mechanisms.

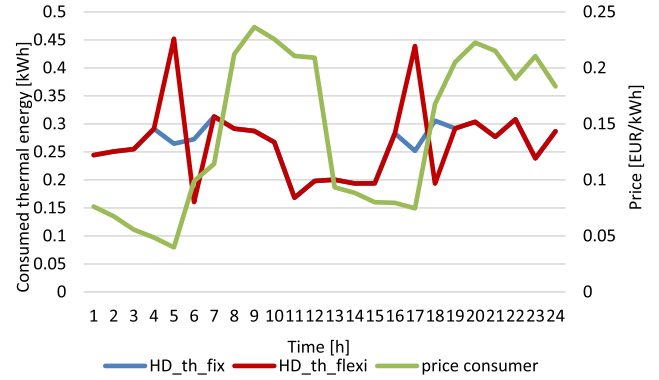

Fig. 10. Consumed energy for thermal heating under market pricing.

Table 4

Results for different number of prosumers equipped with battery storage in Case 4.

	Case 4a			Case 4b		
	25	50	75	25	50	75
% of consumers with battery						
Consumers cost	100.82	90.06	81.07	116.10	106.82	99.14
Penalties	3.57	6.14	7.82	3.90	6.93	8.82
Aggregator’s profit	77.09	65.91	57.04	91.96	81.72	73.90

- Increasing the number of prosumers equipped with batteries results in higher penalties, which means that this type of pricing puts the focus more on the final consumers’ cost reduction than on the balancing.
- Case 4 shows poorer results compared to Case 2. Although increasing the numbers of prosumers equipped with battery storage decreases the total consumers’ cost as shown in Table 4, aggregator’s profit is decreased more with higher penetration of battery storage units. When we consider that aggregators increased profit can be shared among prosumers in order to reduce their costs, pricing proposed in Case 4 do not benefit them cumulatively. This can be seen when comparing consumers’ cost in Case 2 and Case 4 for the same percentage of battery penetration; consumer’s cost is decreased in Case 4, however the aggregator’s profit is decreases even more.

5. Conclusion

The paper discusses opportunities for end consumers to join a new balancing group through their aggregator. This new balancing group is composed of renewable energy sources and exploits characteristics of its members to gain favourable market position and create financial benefits for all its members. In the proposed concept the aggregator creates dynamic price, reflecting those in the market, trying to exploit the flexibility of end consumers and make profit. Simultaneously such pricing scheme should be favourable to the end-consumers when compared to traditional suppliers. The problem is cast as stochastic MILP bilevel model.

The results suggest that only a certain group of prosumers would benefit from signing a contract with the aggregator and having dynamic prices. In fact, only prosumers with smaller capacity PV installations gain benefits from such approach. Their battery storage units, although small in capacity, can enable the wind power plant to store both production during periods of low market prices and to alleviate errors of day-ahead forecasts. On the other hand, prosumers who installed larger PV capacities are more likely to stay with the current two-tariff system of the supplier as their installation enable them self-sufficiency in terms of supply during higher tariffs.

For the case of coordinated market participation of a wind power

plant and an aggregator of active consumers at day-ahead and real-time market, penalties for imbalances are reduced as compared to individual participation, at the same time increasing the profit when looking at the group of BG member. This profit manifests as larger profit of the wind power plant, however this larger profit should be shared among all BG members as it is a result of zero exchange between wind power plants and aggregator members.

The results in the paper demonstrate that increasing the number of prosumers equipped with batteries may not lead to a significant cost reduction. While directives suggest that consumers become active market participants and that new entities such as aggregator should enable that, we find that benefits of doing that are small to negligible under current market mechanisms.

Future work will focus on energy communities which participate in the wholesale market but also allow buying and selling electricity among members of community. The results of this paper suggest that prosumers with larger PV capacities installed might be interested in the opportunity to increase their profit by selling excess PV electricity to other end users. However, the challenge lays in modelling and defining strategical behaviour of the aggregator as well as in determining the prices of peer-to-peer exchange.

CRediT authorship contribution statement

Mirna Gržanić: Conceptualization, Methodology, Writing - original draft. **Tomislav Capuder:** Visualization, Supervision, Writing - review & editing.

Declaration of Competing Interest

The authors declare that they have no known competing financial interests or personal relationships that could have appeared to influence the work reported in this paper.

Acknowledgements

The work is supported by Croatian Science Foundation (HRZZ) and Croatian Distribution System Operator (HEP ODS) supported by project IMAGINE – Innovative Modelling and Laboratory Tested Solutions for Next Generation of Distribution Networks and in part by the Croatian Science Foundation under project Active NeIghborhoods energy Markets pArTicipatION—ANIMATION (IP-2019-04-09164).

References

- Jacobs D. Renewable energy policy convergence in the EU: the evolution of feed-in tariffs in Germany, Spain and France. USA: Ashgate Publishing Company; 2012.
- Beus M, Pavić I, Štritof I, Capuder T, Pandžić H. Electricity market design in Croatia within the European electricity market—recommendations for further development. *Energies* 2018;11(2). <https://doi.org/10.3390/en11020346>.
- Soares T, Pinson P, Jensen TV, Morais H. Optimal offering strategies for wind power in energy and primary reserve markets. *IEEE Trans Sustain Energy* 2016;7(3):1036–45.
- Koraki D, Strunz K. Wind and solar power integration in electricity markets and distribution networks through service-centric virtual power plants. *IEEE Trans Power Syst* 2018;33(1):473–85.
- Rodrigues T, Ramírez PJ, Strbac G. The value of storage for a wind farm offering energy and spinning reserve. 5th IET international conference on Renewable Power Generation (RPG) 2016, 21–23 Sept. 2016, London, UK. 2016.
- Zareifard Mohammad Taghi, Savkin Andrey V. Model predictive control for output smoothing and maximizing the income of a wind power plant integrated with a battery energy storage system. In: 35th Chinese Control Conference (CCC), 27–29 July 2016, Chengdu, China.
- Tan Jin, Zhang Yingchen. Coordinated control strategy of a battery energy storage system to support a wind power plant providing multi-timescale frequency ancillary services. *IEEE Trans Sustain Energy* 2017;8(3):1140–53.
- Lopez Rodriguez Rubén H, Vecchiu Ionel, Jupin Samuel, Bacha Seddik, Tabart Quentin, Pouresmaeil Edris. A new energy management strategy for a grid connected wind turbine-battery storage power plant. In: 2018 IEEE International Conference on Industrial Technology (ICIT), 20–22 Feb. 2018, Lyon, France.
- Ghavidel Sahand, Ghadi Mojtaba Jabbari, Azizivahed Ali, Barani Mostafa, Aghaei Jamshid, Li Li, Zhang Jiangfeng. Hybrid power plant bidding strategy including a commercial compressed air energy storage aggregator and a wind power producer. In: 2017 Australasian Universities Power Engineering Conference (AUPEC), 19–22 Nov. 2017, Melbourne, VIC, Australia.
- Scarlatache Florina, Grigoraş Gheorghe. Optimal coordination of wind and hydro power plants in power systems. In: 2014 International conference on Optimization of Electrical and Electronic Equipment (OPTIM), 22–24 May 2014, Bran, Romania.
- Wangdee Wijarn, Li Wenyuan. Risk pruning under islanding conditions using wind-hydro generation coordination. In: 2016 International conference on Probabilistic Methods Applied to Power Systems (PMAPS), 16–20 Oct. 2016, Beijing, China.
- Liu Yangyang, Tan Shengmin, Jiang Chuanwen. Interval optimal scheduling of hydro-PV-wind hybrid system considering firm generation coordination. *IET Renew Power Gen* 2017;11(1):63–72.
- Bodal Espen F, Hjelmeland Martin N, Larsen Camilla T, Korpås Magnus. Coordination of hydro and wind power in a transmission constrained area using SDDP. In: 51st International Universities Power Engineering Conference (UPEC), 6–9 Sept. 2016, Coimbra, Portugal.
- Clean Energy for all European, available online: https://eur-lex.europa.eu/re-source.html?uri=cellar:fa6ea15b-b7b0-11e6-9e3c-01aa75ed71a1.0001.02/DOC_1&format=PDF.
- Good N, Mancarella P. Flexibility in multi-energy communities with electrical and thermal storage: A stochastic, robust approach for multi-service demand response, August 2017. *IEEE Transactions on Smart Grid* PP(99). <https://doi.org/10.1109/TSG.2017.2745559>.
- Gupta Mitalee. U.S. front-of-the-meter energy storage system prices 2018–2022. Energy Storage Research, gtm research: <https://www.greentechmedia.com/research/report/us-front-of-the-meter-energy-storage-system-prices-2018-2022#gs.B2tjz0s>.
- Yang J, Zhang GG, Ma K. Demand response based on Stackelberg game in smart grid. In: Control Conference (CCC), 26–28 July 2013, Xi'an, China.
- Chen J, Yang B, Guan X. Optimal demand response scheduling with stackelberg game approach under load uncertainty for smart grid. 2012 IEEE Third International Conference on Smart Grid Communications (SmartGridComm), 5–8 Nov, Tainan Taiwan. 2012.
- Maharjan S, Zhu Q, Zhang Y, Gjessing S, Başar T. Dependable demand response management in the smart grid: a Stackelberg game approach. *IEEE Trans Smart Grid* 2013;4(1):120–32.
- Kovacs A. Bilevel programming approach to optimizing a time-variant electricity tariff for demand response. In: 2016 IEEE International Conference on Smart Grid Communications (SmartGridComm), 6–9 Nov. 2016, Sydney, Australia.
- Liu N, Yu X, Wang C, Wang J. Energy sharing management for microgrids with PV prosumers: a Stackelberg game approach. *IEEE Trans Ind Inf* 2017;13(3):1088–98.
- Cui S, Wang YW, Liu N. Distributed game-based pricing strategy for energy sharing in microgrid with PV prosumers. *IET Renew Power Gen* 2018;12(3):380–8.
- Ma L, Liu N, Zhang J, Tushar W, Yuen C. Energy management for joint operation of CHP and PV prosumers inside a grid-connected microgrid: a game theoretic approach. *IEEE Trans Indust Informatics* 2016;12(5):1930–42.
- Liu N, Yu X, Wang C, Li C, Ma L, Lei J. Energy-sharing model with price-based demand response for microgrids of peer-to-peer prosumers. *IEEE Trans Power Syst* 2017;32(5):3569–83.
- Liu N, Cheng M, Yu X, Zhong J, Lei J. Energy sharing provider for PV prosumer clusters: a hybrid approach using stochastic programming and Stackelberg game. *IEEE Trans Indust Electron* 2018;65(8):6740–50.
- Alshehri K, Liu J, Chen X, Basar T. A Stackelberg game for multi-period demand response management in the smart grid. In: 2015 IEEE 54th annual conference on Decision and Control (CDC), December 15–18, 2015, Osaka, Japan.
- Yu M, Hong SH. A real-time demand-response algorithm for smart grids: a Stackelberg game approach. *IEEE Trans Smart Grid* 2016;7(2):879–88.
- Motaleb M, Branigan J, Ghorbani R. Demand response aggregator stackelberg competition for selling stored energy. In: Power & energy society general meeting, 2017 IEEE, 16–20 July 2017, Chicago, IL, USA.
- Fan H, Yu M. A new two-stage game framework for power demand/response management in smart grids. In: 2017 IEEE 14th International Conference on Networking, Sensing and Control (ICNSC), 16–18 May 2017, Calabria, Italy.
- Zugno M, Morales JM, Pinson P, Madsen H. A bilevel model for electricity retailers' participation in a demand response market environment. *Energy Econ* 2013; 182–97.
- Dvorkin Y, Wang Y, Pandžić H, Kirschen D. Comparison of scenario reduction techniques for the stochastic unit commitment. In: IEEE PES general meeting, 27–31 July 2014, National Harbor, MD, USA, 2014, pp. 1–5.
- Punda L, Capuder T, Pandžić H, Delimar M. Integration of renewable energy sources in southeast Europe: a review of incentive mechanisms and feasibility of investments. *Renew Sustain Energy Rev* 2017;71:77–88.
- <https://www.solarquotes.com.au/battery-storage/comparison-table/>.
- Conejo AJ, Carrion M, Morales JM. Decision making under uncertainty in electricity markets. Springer; 2010. <https://doi.org/10.1007/978-1-4419-7421-1>.
- <https://www.french-property.com/guides/france/utilities/electricity/tariff/> <https://www.agence-france-electricite.fr/prix-electricite/kwh/comparaison/>.
- Fortuny-Amat J, McCarl B. *J Oper Res Soc* 1981;32:783. <https://doi.org/10.1057/jors.1981.32.783>.



Contents lists available at ScienceDirect

Renewable and Sustainable Energy Reviews

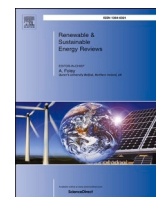
journal homepage: www.elsevier.com/locate/rser

Prosumers as active market participants: A systematic review of evolution of opportunities, models and challenges

M. Gržanić^{a,*}, T. Capuder^a, N. Zhang^b, W. Huang^b^a Faculty of Electrical Engineering and Computing University of Zagreb, Zagreb, Croatia^b Tsinghua University, Beijing, China

ARTICLE INFO

Keywords:

Aggregation
Demand response
Dynamic price signals
Energy community
Prosumers
Microgrids
Peer-to-peer trading

ABSTRACT

The possibility of onsite production and flexible consumption is transforming consumers from passive users to active service providers in power systems with the large share of renewable energy sources. The prosumer-centric paradigm brings diverse possibilities by introducing real-time (RT) pricing, enabling easy and fast change of the supplier, creating opportunities for aggregation, enabling local energy production and local energy exchange, as well as the provision of ancillary services. The paper brings a comprehensive review of the evolution of the diverse options for prosumer to exploit their potential. It starts with the analysis of models and opportunities for a single end-user who decided to invest in Photovoltaic (PV), electric vehicles, and flexible devices. Aside from the review, the paper challenges the logic of the prosumer responding to dynamic prices and providing power system flexibility and compares it with the logic of lowering only their electricity bill. It further analyses different types of aggregation, such as energy communities or microgrids, combined market participation with RES, but also decentralization models designed to stimulate internal energy exchange and solve network problems locally. Finally, it discusses the possibility of providing service to both Transmission and Distribution System Operator and the complexity such coordination requires when procuring flexibility services from resources connected to the distribution network or aggregated prosumers. In addition to a comprehensive review and discussion, the paper brings easy-to-understand models and belong results for the reviewed cases of a) single prosumer flexibility, b) aggregated multiple flexible prosumers, c) energy community with the possibility of peer-to-peer trading.

1. Introduction

The European Commission has recently raised the ambition in reducing greenhouse gas emissions by at least 55% (from 40%) by 2030 compared to 1990 [1]. Moreover, renewable energy share is set at 32%, while the required improvement in energy efficiency should be at least 32.5%. As a mean to achieve these goals, the European Commission emphasizes the importance of full participation of final customers in the energy transition [2]. The promotion of fair competition is seen through allowing consumers to take advantage of the liberalized internal market for electricity and to freely choose their energy supplier. Prosumers will have an essential role in providing the flexibility necessary for the future power system with high integration of renewable energy sources. Changes in grid management open the door for final customers enabling their active participation in the energy market to fully exploit their potential. Prosumers should benefit from participating directly in the

market or by adjusting their flexible behavior according to the market signals (either through lower electricity prices or incentive payments). These benefits will increase over time and encourage passive consumers to become active market participants. Prosumers should be able to participate in all forms of demand response (DR) programs, benefiting from installing smart meters and choosing dynamic prices. All barriers should be removed in order to enable consumption, storage, self-generation, and electricity sale in the market from the prosumer's side. If prosumers are engaged in the aggregation of DR, Transmission System Operator (TSO) and Distribution System Operator (DSO) should treat them in a non-discriminatory manner in the process of ancillary service (AS) procurement. The regulatory framework for consumers engaged in aggregation should define non-discriminatory and transparent rules about information exchange and an obligation for financial responsibility for the imbalances they cause in the electricity system. DSOs shall ensure the effective and non-discriminatory participation of all market participants in AS provision, including market entities

* Corresponding author.

E-mail address: mirna.grzanic@fer.hr (M. Gržanić).

Abbreviations and nomenclature

AC	Air Condition	SWPT	Step-Wise Power Tariff
ADMM	Alternating Direction Method of Multipliers	RT	Real-Time
AS	Ancillary Service	SDP	Supply Demand Ratio
BES	Battery Energy Storage	ToU	Time-of-Use
BS	Bill Sharing	TSO	Transmission System Operator
CL	Curtaillable Load	VPP	Virtual Power Plant
CEMS	Community Energy Management Systems [€/kWh]	WPP	Wind Power Plant
CPP	Critical Peak Pricing	$\lambda_t^{DA B}$	DA buying price [€/kWh]
DA	Day-Ahead	$\lambda_t^{DA S}$	DA selling price [€/kWh]
DLC	Direct Load Control	$\lambda^{BAL B}$	Buying balancing fee [€/kWh]
DER	Distributed Energy Resources	$\lambda^{BAL S}$	Selling balancing fee [€/kWh]
DR	Demand Response	$\lambda^{NET B}$	Network charges [€/kWh]
DSO	Distribution System Operator	π_s	Probability of scenario s
EV	Electric Vehicles	λ_t^{UP}	Flexibility up incentive [€/kWh]
FIT	Feed-in Tariffs	λ_t^{DOWN}	Flexibility down incentive [€/kWh]
HA	Household Appliance	$P_t^{DA B}$	DA buying schedule [kW]
HEMS	Household Energy Management System	$P_t^{DA S}$	Da selling schedule [kW]
IL	Interruptible Load	$P_{d,t}^B$	Bought power [kW]
IEMD	Internal Electricity Market Directive	$P_{d,t}^S$	Sold power [kW]
MILP	Mixed-Integer Linear Programming	$P_{s,t}^{UP}$	Up deviation [kW]
MMR	Mid-Market Rate	$P_{s,t}^{DOWN}$	Down deviation [kW]
PEV	Plug-in Electric Vehicle	$P_{s,t}^+$	Positive net load [kW]
PV	Photovoltaic	$d \in D$	Household d
P2p	Peer-to-Peer	$s \in S$	Scenario s
RED	II European Union Renewable Energy Directive	$t \in T$	Time period t
SL	Shiftable load		

offering energy from renewable sources, market participants engaged in DR, operators of energy storage facilities, and market participants engaged in aggregation. Delivery of balancing services from consumers has to be agreed with the relevant TSO [3].

According to the mentioned regulatory framework, final customers are put in the center of the green energy transition. To fully exploit their flexibility, final customers should be able to participate in the energy and AS market. This area is under fast development, while the detailed review is valuable for the research and future implementation in this field.

2. Motivation and contributions

2.1. State-of-the-art review papers on different pricing mechanisms, DR programs and peer-to-peer trading

Different types of incentives will encourage passive consumers to become active market participants, either through dynamic market prices, reduced network fees, innovative types of pricing mechanisms for the members of new balancing groups, either energy communities or microgrids, direct trading, and negotiating prices between prosumers using different game theory strategies, etc. Many review papers investigated different pricing mechanisms for incentivizing the flexible behavior of a final customer.

The focus of the paper [4] is put on time-of-use (ToU) and time-of-exports tariffs with different levels of integration of the battery energy storage (BES), photovoltaic (PV), and heat pumps. The results show that these tariffs do not significantly affect peak flows in the low voltage network. However, the usage of BES had a negative impact on peak flows during the overnight off-peak period due to the simultaneous charging of all batteries. The review paper [5] addresses the categorization of demand-side management based on the theoretical framework. The focus is put on the concept presentation of each demand-side management model, classifications methods, together with their

descriptions and objectives. Albeit precise categorization is presented in Ref. [5], our paper categorizes DR programs based on the type of optimization algorithm with a detail description of each case study, methodology and quantitative results, which was not covered in Ref. [5]. The paper [6] gave a comprehensive review of residential DR programs communication technology and challenges with load scheduling. Moreover, the paper proposes a novel multi-consumption level pricing scheme to deal with the unfairness in price rates determined for all consumers which are affected by the small number of consumers with high consumption. This type of pricing mechanism provides an amount of reduction from the consumer's side in order to stay at the lower pricing rate. However, the paper did not classify references, just pointed out the type of control or DR type. The paper [7] described demand-side management and categories of DR programs. The focus is put on the difference between the price maker and the price taker in the electricity markets. It is described how bidding strategies based on game theory, forecasting and estimation-based methods can change the retailer's role from price taker to price maker with flexible prosumers willing to participate in DR programs. The paper [8] described price-driven DR programs: critical peak pricing (CPP), TOU pricing, and real-time (RT) pricing and peak time pricing. The numerical example described in the paper shows that DR increases peak demand by 11.29% and decreases cost by 2%–7.5%. The paper introduces a 9-step p2p trading cycle that will help the aggregator to reduce expensive electricity purchase. The references in the paper were grouped only regarding different types of price-driven DR.

The authors in Ref. [9] classified different types of DR programs in conventional, heuristic and based on game-theory from the residential user modelling perspective (including local generators, smart devices, energy storage units, energy management units). DR programs are grouped according to user interaction (individual and cooperative users), optimization approach (deterministic and stochastic), time-scale (DA and RT), the objective function (bill minimization, discomfort minimization, maximization of local generation use). Moreover, the

paper described integrated DR programs in heat and electricity systems and also in electricity and gas systems. A systematic literature review in Ref. [10] describes financial incentives for investors in low-carbon technologies: feed-in tariffs (FiT), quota-based schemes, feed-in premium, tax incentives, grants, soft loans, etc. The work in Ref. [11] presents an extensive overview of p2p energy trading through research projects and the design of p2p energy markets (full p2p market, community-based market, hybrid p2p market). A detailed description of advantages and challenges is given for each market design. Despite the high quality of this review paper regarding p2p energy trading, the focus is put only on p2p energy trading and does not investigate any other incentives for flexibility. The focus in Ref. [12] is put on the aggregator in the smart grid environment serving as a mediator between DR programs providing AS from the end-user side and the power system. Technical and policy barriers are investigated and changes in aggregator's responsibilities are described (transition from a simple role, such as managing energy storage units, to promoting flexibility from the final customers and their participation in the energy market). The paper [13] analyzed with two textual and scientometric analysis tools over 1000 papers to investigate the number of publications focused on the prosumer, DR, flexibility, smart grid, etc. in recent years and the results emphasize that the proposed topic is of great interest.

2.2. The evolution of electricity prices

The authors in Ref. [14] described how household electricity prices changed in the EU related to energy sector transformation (liberalization). Albeit the price regulation is still present in some member states, household electricity prices are affected by the oil price and the share of renewable energy sources in all member states. Market liberalization resulted in a decrease on household electricity prices due to new market actors and increased competition. The authors in Ref. [15] consider social acceptability costs together with operational and investment costs in DR programs. The pricing mechanism derived in the paper is focused on avoiding extreme peak prices capturing the resistance to DR programs as the cost which should be minimized. The described approach can have an impact on decreasing the social acceptability cost and serves as a valuable indicator for initiating policy changes regarding distributed energy resources (DER). The work in Ref. [16] distinguishes different DR programs, such as incentive-based (direct load control (DLC), curtailable load (CL), demand bidding, emergency demand reduction) or price-based (ToU, RT pricing, critical peak pricing, inclining block rate). However, this paper focuses on the review of DR optimization problems and classifies papers in different categories according to the type of optimization used in the model (but does not classify according to different pricing mechanisms), such as linear programming, mixed-integer linear programming, non-linear programming or mixed-integer non-linear programming models, metaheuristic algorithms (particle swarm optimization, genetic algorithm, simulated annealing algorithm). The authors in Ref. [17] concluded that RT pricing is less favorable than static ToU tariffs with fixed peak and valley values. Moreover, the paper investigated the willingness of up-taking ToU tariffs considering the effort in overcoming consumers' inertia. As consumers rarely switch suppliers, it is important to find effective recruitment methods to attract new customers. On the other hand, if customers are recruited onto ToU tariffs by default, uptake to ToU prices can reach between 57% and 100%. Changes in business models in smart energy pricing over the last 50 years were investigated in Ref. [18] with a detailed description of price theories and their application in energy pricing (cost-based pricing, differential pricing, product line pricing strategy, complementary pricing). The paper did not consider any DR programs or different types of pricing today, however, it serves as an extensive review of energy pricing changes in history which can help in determining future tariffs. The potential of DR programs based on real measurements and dynamic prices crated day-ahead (DA) was demonstrated in Ref. [19]. The dynamic tariff used in this research was

described with blocks of 2 h linked to local generation. The results proved that this type of pricing is sufficient for participation in DR and that there is no need for more dynamic changes in price signals.

2.3. Contributions

The review papers mentioned above elaborate only a specific domain of prosumer's opportunity to exploit their flexible potential in order to lower their electricity bill and contribute to carbon neutrality (p2p trading, community trading, DR programs, AS provision, etc.). The idea of the transition towards a carbon-neutral power system is prosumer-centric oriented. Our paper connects the steps in this transition highlighting different benefits for flexible prosumers in each step: from passive consumers who invest in different types of low-carbon technology and follow price signals to reduce their electricity cost, leading to the aggregation of final users which increase local RES consumption and p2p energy trading which results in more beneficial electricity price. Finally, prosumers can be aggregated to provide flexibility to the system and get additional remuneration. The references in the paper are grouped based on the used optimization techniques with a detailed description of case studies, methodology, benefits, and quantitative results.

For the first time, the review paper compares the benefits for the final consumer under different pricing options considering each component of the consumer's electricity bill (not only energy part but also taxing policy, network charges, system charges, fixed charges for measurement, etc.) in three European countries which are in the different stage of market liberalization.

The contribution of our paper is divided in 2 parts:

- The review of pricing evolution and strategies which bring different opportunities for the prosumer. All mentioned review papers in the literature review focus on a narrow area exploring diverse possibilities for the end-user, either reviewing different pricing mechanisms and strategies in explicit or implicit DR programs or describing different types of p2p trading. On the other hand, this paper provides a systematic review of all options that encourage prosumers' flexible behavior. Firstly, by following price signals final prosumers achieve lower electricity cost. Secondly, aggregation in microgrids or energy communities brings additional savings. Thirdly, p2p trading arises as an additional option where prosumers can trade locally. And finally, to foster low-carbon energy transition, providing AS to the system operator contributes to the overall system's flexibility and brings an extra profit to final prosumers.
- Easy to understand mathematical modelling and optimization based results for evaluation of single prosumer's flexibility value and profitability investment in low-carbon technology under different price signals and flexible device options in Denmark, Spain, and Croatia. These models extend to the economic evaluation of different opportunities/concepts of prosumer's aggregation.

The rest of the paper describes the evolution of the final customer's behavior under different types of incentives, pricing mechanisms, aggregation and AS provision as shown in Fig. 1:

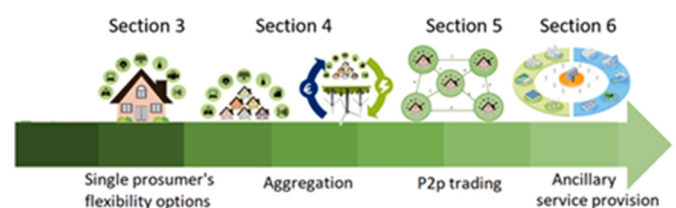

Fig. 1. The evolution of final customer's role in the power system low-carbon transition.

Section 3 focuses on stimulating individual prosumer’s flexible behavior under supplier: the evolution of end-user pricing tariffs from a flat rate to dynamic RT pricing as part of price-based DR and incentive-based DR with direct price signals for load reduction or load shifting. To enable the direct market participation of final customers, Section 4 describes the different forms of flexible prosumers aggregation in the market, such as energy communities, microgrids, energy cooperatives, etc. Moreover, to achieve lower electricity costs, internal energy markets are being established in which prosumers exchange energy with p2p energy trading as described in Section 5. To fully exploit the potential of final customers, Section 6 describes the aggregation of final customers in the AS market for providing flexibility to the TSO and DSO with a detailed description of different TSO/DSO coordination mechanisms. Section 7 models consumer’s flexibility under different pricing mechanisms in Europe to investigate how currently established pricing mechanisms motivate prosumers to change their consumption patterns and benefits of aggregation. The conclusion is highlighted in Section 8.

3. Different pricing strategies from a supplier stimulating flexible behavior

Traditionally, the consumers had access to electrical energy only through the limited number of suppliers who acted as mediators between them and a power system. Suppliers were responsible for energy delivery and setting electricity costs for each end-user which includes network charges, energy cost, system operator costs, taxes, and incentives for renewable energy sources. Moreover, suppliers used to manage the risk arising from the price difference between prices set to the consumers and purchase energy price. Final customers could not change the terms of their contract, choose between different pricing options, and sometimes even switch the supplier. Market liberalization and the awareness of the harmfulness of climate changes resulted in significant changes towards final customers. Recent EU directives recognized the final customer as the leader in clean energy transition highlighting the importance of transparent pricing options and terms which have to be offered to each individual customer.

The higher number of suppliers compete between themselves offering competitive electricity prices under different pricing strategies to gather a higher number of consumers aiming to achieve higher profit. They stimulate the flexible behavior of the final customer inducing higher consumption during the period of low market prices. These actions are classified as price-based DR programs which can improve energy efficiency seen through energy savings in final consumption or optimal use of generation units, transmission and distribution networks [20]. The second type of DR is incentive-based DR programs which offer incentives to final customers for their load control in addition to their electricity supply contract. The division of DR programs is shown in Fig. 2 with an illustrative example of price-based DR programs:

Price-based DR programs are categorized into 5 groups as presented in Fig. 2: ToU, critical pricing, peak-time rebates, step-wise power tariff (SWPT), and RT pricing. ToU tariff refers to two or more prices

alternating during the day which are known in advance and remain constant for the duration of the contract. Duration of one price covers the large time blocks of several hours (e.g. lower prices during the night and higher prices during the day) [21]. Critical peak pricing (CPP) refers to a significant increase in electricity prices during peak hours on critical days that are announced in advance. Peak-time rebates provide a rebate for active consumers who agree to shift energy usage during peak hours. In SWPT, electricity quantity is divided into steps. Each step corresponds to a unit price which increases with steps. The clearing price per month is equal to the sum of the product of consumed electricity quantity in each step and its corresponding price [22]. RT pricing is represented with short-time-interval varying electricity prices (usually hourly) announced the day before energy delivery which reflect market prices. Nowadays, due to rising awareness of final customer’s contribution to green energy transition and financial opportunities in reducing their electricity cost, consumers are investing in different types of low carbon technology, such as PV, BES, EV, or have more flexible preferences of household appliances (washing machine, air conditioning (AC), heating, etc.). Consumers change their behavior in order to reduce their electricity cost, total consumption, or peak load. Recent papers demonstrating the impact of described price-based DR on final prosumer’s consumption are listed in Table 1 and grouped according to the optimization algorithm used in the model showing type and size of low carbon technology, methodology, and the effect of prosumer’s flexible behavior on their cost. The column location specifies either the real location of prosumers or the resource of data used for the simulation purpose. Albeit most of the literature algorithms are not used in reality, Smart grid demonstration project is implemented in Suzhou, Jiangsu Province, China [23], FlexElec Laboratory in University of Nottingham [24], EnergyPlus model testing on Irish single floor building is performed in Ref. [25], CPP was tested in Higashida area of the City of Kitakyushu [26] [27], National Rural Electric Cooperative Association in Arlington, USA tested reduction of energy and peak-demand cost [28] with different types of electricity prices. Details of the projects together with other references and are specified Table 1.

As shown in Fig. 2, incentive-based DR programs are divided into 4 categories: DLC, CL programs, IL programs and marked-based solutions.

DLC refers to a control of the end user’s load (AC, lighting, water heating, pool pumps) from the system operator’s side. The Black electricity tariff in Croatia is a realistic example of DR program for households [51]. The supplier determines when the energy will be delivered to the final customer. It is used for boilers, heating systems and appliances for which energy consumption can be shifted. Ripple control is used in Switzerland, Hungary, Czech Republic, and Slovakia as an instrument to control load in order to keep the electric network stable. It is a superimposed higher-frequency signal that is put on the standard power signal (50 Hz). Loads can be switched off and on in this way and it is used for public street lamps, electric boilers and heaters [52,53].

The system operator specifies the maximum number of events in a year and the maximum duration of the required service (turning off the load for a predefined time period). The system operator controls the load

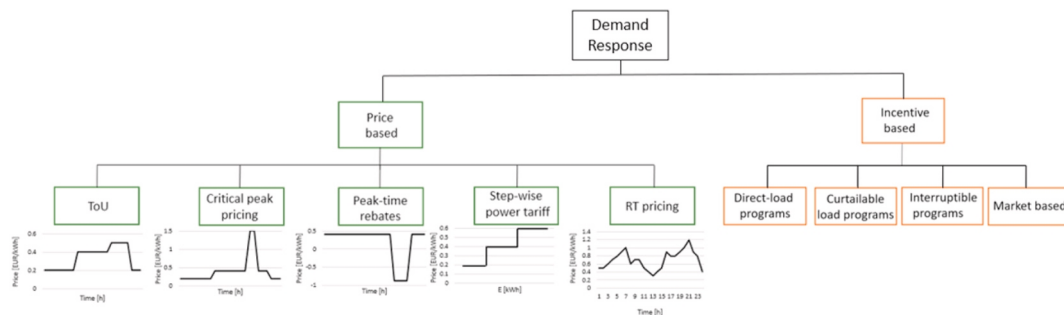

Fig. 2. Types of DR programs.

Table 1
Price-based DR.

Type of optimization	Reference	Price	Benefits/ disadvantages	DERs	Methodology	Dimension	Location	Results
Bilevel and bilevel heuristic	[29]	TOU	Cost reduction compared to the case without DERs	PV, battery, diesel generator	Cost minimization	Max power exchange with grid about 1 MW	Pakistan typical summer and winter data	37 % cost reduction with PV, 31% cost reduction with PV and battery
	[30]	TOU SWPT RT	Cost reduction under different rate of PV subsidies with battery installation	PV, battery	Bilevel optimization Upper level: PV and BESS sizing Lower level: household energy cost minimization	PV size: 45-55kW Battery size: 35-75 kWh	Guangzhou, China electricity prices and PV subsidy	BESS not profitable under SPT, PV sizing sensitive more to the electricity subsidy compared to capacity subsidy
Game theory	[31]	TOU SWPT	Reduction of total electricity consumption per month, maximum hourly consumption, the difference between peak-valley and total cost	Price-based DR	Multi-objective tariff-making Pareto optimization problem	Peak consumption 10 MW	Residential load data from Hunan Province, China	TOUSPT tariff with better performance compared to ToU and SPT
	[32]	SWPT	Cost reduction, increase of penetration level of RES and EVs	Demand response	Consumer's payoff function based on degree of information shared between other consumers and Bayesian Nash equilibrium	Up to 100 households, commercial, industrial and agricultural consumers	Jaipur Vidhut Vitran Nigam Limited Tariff for supply of electricity supply	Cost reduction for a household is 4\$ (1.3%), for commercial consumer 23 \$ (1%)
Heuristic	[33]	TOU CPP	Different types of ToU prices for commercial buildings according to max peak demand cause load shifting with lower peak demand and switching to cheaper ToU category	PV, thermostatically controllable load, lighting	Reduction of demand charges in 4 steps: identification of decision variables, energy and cost model formation, quantification of parameter uncertainty, stochastic optimization	Commercial buildings: office, hospital, retail building with peak load 250-300kW	Southern California Edison prices	Peak reduction by 30%
	[34], [35]	CPP RT	Minimization of electricity cost, peak to average ratio and user waiting time	Household appliances, battery	Cost minimization problem solved with genetic algorithm, Cuckoo Search Optimization Algorithm and Crow Search Algorithm	Single household with 8kW peak and group of 30 households with 250 kW peak	Not specified	RTP reduces electricity cost by 12-15% without battery and 16-23% with battery CPP reduces electricity cost by 22-25% without battery and 22-41% with battery
	[36]	CPP RT	Reduction of electricity cost and peak load demand	Household appliances	Energy management system cost minimization using the hybrid gray wolf differential evolution	Household with 17 appliances with 5.5 kW peak	Not specified	RTP reduces electricity cost by 12% CPP reduces electricity cost by 11-13%
	[37]	SWPT RTP TOU	Cost savings	PV, battery	Capacity allocation of PV and BESS under uncertainty and different pricing mechanisms	Typical household with 20 kW peak, 45 and 55 kW PV, 5,10,35,75kWh BESS	Foshan region, China	5.9%, 3.0%, and 4.8% cost reduction under SWPT, RTP, and TOU tariffs compared to the flat tariff
	[38]	RT	Cost minimization, peak load mitigation	PV, electric and thermal storage, uninterruptible and curtailable appliances	HEMS optimizes the electricity usage based on retailer's electricity price reducing Peak-to-Average load profile	30 kW PV, 90 kWh BESS	Copenhagen, Denmark	HEMS reduces 18%-25% cost reduction, 6.1%-8.3% peak load reduction

(continued on next page)

Table 1 (continued)

Type of optimization	Reference	Price	Benefits/disadvantages	DERs	Methodology	Dimension	Location	Results
Machine learning	[39]	TOU	Higher peak and cost reduction for users with better behavioral control Higher price increase in the peak time does not result in higher demand reduction	Water heating devices, dishwasher	Determination of drivers enhancing users' responsiveness on the price change based on machine-learning approach	Typical household	Irish electricity prices	Peak reduction by 8.5% in base case and 20% after applied methodology
	[25]	TOU	Reduction of end-user's expenditure, utility generation cost, carbon emissions	PV, heat pump, thermal storage	Electricity cost minimization using smart energy management system with price prediction and weather forecast	Aggregated electricity consumption with hourly maximum consumption from 50-70 kWh	Ireland	Reduction of heating system costs and carbon footprint up to 40 %, reduction of electricity cost up to 50%
Backward two-stage stochastic programming	[40], [41]	PTR	Reduction of consumption during peak prices considering loss-aversion	Demand response	Two-stage stochastic consumer's payoff model based on Von-Neumann and Morgenstern theory	Load up to 20 MWh	Not specified	Based on incentive compared to the retail price, consumers decide to alter their consumption which sometimes can be harmful to the system
Multi-objective optimization	[42]	RT	Energy expense minimization considering desired comfort preferences and lifestyles	thermally controlled appliances, battery, interruptible and non-interruptible appliances	HEMS cost minimization with smart appliances operation	Max hourly consumption 6 kWh, max 1.2 kW PV production, 8 kWh BES	Not specified	Albeit 20 % higher cost occurs when consumer's preferences are respected, the value of proposed scheme lies in investigating diverse flexibility options considering the user's comfort
Direct optimization	[43]	TOU	Minimization of the total cost of the power supply chain and optimization of the charging-discharging behaviors of end-users	Battery	Minimization of power supply chain cost	200 000 end users	Not specified	Reduction of total system load, peak shaving
	[44]	TOU	A higher solar compensation increases the PV adoption and decreases the value of storage, while the time differentiation of the ToU component of the tariff increases the adoption of storage resulting in voltage deviations	PV, battery	Long-term effect of the electricity price design on the voltage level considering DERs	Medium voltage distribution network with 118 buses	PV data from San Francisco	Size of PV investment is 50% higher in case of the same buying and selling price compared to the case with 0.5 electricity price ratio
	[23]	TOU CPP RT	Minimization of user's electricity cost without interfering user's comfort, decrease of residential peak load and energy consumption	PV, EV, shiftable load, battery, air conditioner	Cost electricity minimization	Residential loads with 2 MW peak	Not specified	Peak load reduction by almost 4%, peak-valley difference decrease by 9.04%, total energy consumption reduction by 1.07%

(continued on next page)

Table 1 (continued)

Type of optimization	Reference	Price	Benefits/disadvantages	DERs	Methodology	Dimension	Location	Results
	[45]	TOU	ToU tariffs increase the profitable size of PV	PV, battery	Profitability evaluation for PV and battery	Apartment building and detached house	Finland load and price data	Nominal power of PV 30-40% of maximum power usage
	[24]	TOU	Energy management system reduces daily household energy costs and maximizes PV self-consumption	PV, battery	Two layer HEMS with model predictive control optimizing energy usage	Typical household with 5kW peak	UK electricity prices	Electricity cost decreased by 30%, PV self-consumption by 10%, forecasting errors by 5-7%
	[46]	TOU RT	Household with a high preference for electricity do not changes their electricity consumption Household with a low preference for electricity slightly changes the indoor temperature	Air conditioning, lights, electric appliances	Utility maximization of a household reacting on diverse price signals approximated with Cobb-Douglas function considering consumer's preferences for load shifting and household income	Household with 18 kW peak	Saudi Arabia	Lower average unit price for household with low preferences for electricity; more than 30% of reduction in electricity consumption compared to the base pricing
	[47]	TOU	Higher electricity tariffs yield to PV-storage integration and improved household self-sufficiency	PV, battery	Minimization of consumer's electricity bill optimizing the battery schedule under Feed In Tariff or Net Metering pricing	Typical American household with 20kWh battery	Austin, San Diego, Boulder	More than 70% self-sufficiency with installed battery storage, battery and PV will become profitable when retail electricity prices rise beyond \$0.40/kWh and Feed-in-Tariff are below \$0.10/kWh
	[48]	RT	Cost savings	Shiftable and sheddable load, on-demand load, EV	Multi-Agent System framework optimizing the operation of household appliances based on price-based DR and electricity sensitivity	EV 27.4 kWh capacity, peak load 12 kW	China	Electricity consumption reduced by 7%, cost reduced by 34%
	[49]	PTR RT	Higher load reduction without considering behavioral characteristic of loss aversion compared to RT pricing	Demand based on price elasticity	Model of price elasticity for peak reduction using peak-time rebates and real-time pricing	Load profile of Connecticut with maximum hourly consumption 4250 kWh	Hourly data from New England ISO	5.71% electrical consumption reduction with peak-time rebates and 6.11% with real-time pricing
	[50]	CPP	Highly responsive customers decrease their demand and reduce the electricity cost	Demand based on elasticity constant	Profit maximization of load serving entities with a creation of CPP signals and how they affect consumers	Load serving entity portfolio with 4200 MW peak	Load data from Pennsylvania-New Jersey-Maryland Interconnection	More than 3% of profit increase under CPP compared to uniform pricing for utilities and 1% of cost reduction for final users
Developed software	[27]	CPP	The reduction of electricity cost	Household demand	Minimization of electricity consumption using a fixed-effects logistic regression model	176 households	Higashida area of the City of Kitakyushu	6-9% electricity usage reduction under CPP
	[28]	TOU CPP PTR	Reduction of energy and peak-demand cost, reduction of annual demand	Demand response	Open Modeling Framework calculating cost benefit analysis considering different types of pricing	Utility portfolio with 3300 kW peak power	Arlington, USA	Reduced annual consumption by 0.15% and peak-demand cost by 0.5% with DR
	[26]	CPP	Unlike office buildings, high response of	Price-based DR	Demand response reaction on CPP signals	Size of typical office building, residential and	Kitakyushu Smart Community,	the goal is to achieve 20% energy savings and

(continued on next page)

Table 1 (continued)

Type of optimization	Reference	Price	Benefits/ disadvantages	DERs	Methodology	Dimension	Location	Results
			residential and commercial customers with electricity consumption savings and curve shape effect			commercial customers scaled on p.u. values	Higashida District	CO2 emission reduction over 50% with CPP

directly with no advanced announcement or very shortly before the load is turned off. Consumers receive fixed monthly payments with or without an additional payment if the load control is called. In CL programs, consumers agree to turn off the load for a predefined period of time notified by the utility in advance (several minutes or hours in advance, or even a day before the service is required). The consumer turns off the load manually or automatically, as agreed in the contract, and faces the penalty cost if does not turn off the required amount of load. The maximum duration of the service and the annual maximum time of activation are defined in advance. Incentives can be diverse, from a monthly capacity credit (EUR/kW) with or without an activation charge (EUR/kWh) to market pricing. A consumer willing to participate in IL programs agrees on partly or completely load interruption in the case of the extremely high market price or when system reliability is jeopardized. Consumers and utility sign a contract specifying the volume of load that can be interrupted, the compensation for providing the service (fixed monthly incentive with or without activation fee and non-performance penalty) with the maximum duration for one activation, the maximum number of calls, and the condition when the service can be activated.

Recent papers demonstrating the impact of incentive-based DR programs are shown in Table 2 and grouped according to the used optimization algorithm:

4. Aggregation of flexible prosumers

With the decreasing prices of DERs and increasing awareness of the harmful effects of greenhouse gas emissions, final customers start to invest in rooftop photovoltaic systems, BES, electric vehicles, and smart home energy management systems. The transition towards a carbon-neutral power system transforms the final customers from completely passive participants to active prosumers who can consume, store, produce, and flexibly manage electricity. As described in the previous Section, final customers can choose between different pricing strategies to achieve lower electricity costs based on their consumption habits and preferences. Investments in different types of DERs transform the final customer from a completely passive entity to a flexible prosumer. Final customers, such as households or apartment buildings, are usually small entities without any market power. To unleash their full potential, they can be grouped and represented by an aggregator as a single entity that strategically bids on the energy market to achieve lower electricity costs. Small-scaled aggregated prosumers cannot affect the market-clearing price and act as price-takers [95–99]. On the other hand, with the increasing number of aggregated prosumers, aggregator as a price-maker can have a significant impact on the market price and has to choose an adequate bidding strategy to ensure the most beneficial market position [100–103].

4.1. Prosumers and RES - joint market participation

To ensure broad integration of RES, aggregated flexible final prosumers can jointly participate on the market with big renewable energy producers to minimize the negative effects of the uncertain and intermittent nature of RES [104,105]. A wind power plant (WPP) in Ref. [104] participates in the DA market trying to maximize the profit

and employees DR to smooth the power variations and deal with price uncertainty. In the first stage, WPP bids on the DA energy market and reserves the DR flexibility from the active prosumers, while in the second stage the WPP activates the reserved flexibility from the DR provider in order to minimize the balancing cost. In Ref. [106], WPP in a microgrid coordinates with plug-in electric vehicles (PEVs) in order to achieve a power balance between supply and demand taking into account uncertainties arising from the stochastic nature of WPP and PEVs. In Ref. [107] the aggregator of PEV participates in the DA energy market and offers balancing services to WPP through the model of virtual BES considering the uncertainty of driving patterns and WPP production. The bilevel formulation of WPP using active prosumers engaged in DR programs to successfully manage uncertainty is described in Ref. [108]. The upper-level minimizes the cost of conventional generation companies, WPP imbalance cost, and demand reduction price of flexible loads, while the lower-level maximizes the aggregator's profit from employing DR. The model was tested to investigate the impact of different levels of WPP and DR penetration. Results show that minimum operational cost is achieved with high penetration of WPP and low employment of active prosumers clustered in DR programs. The authors in Ref. [109] present bilevel controlling approach of WPP regulation with thermostatically controlled loads. The first level controller is used to model load following WPP production, while the second level controller is used for frequency regulation which keeps the frequency deviation at zero. A stochastic two-stage multi-objective bilevel market formulation modelled as a Stackelberg game is presented in Ref. [110]. Conventional power plants, WPP and the aggregator of active prosumers participating in DR are leaders in the upper-level, while independent system operator is a follower in the lower-level. The upper-level maximizes the revenue of CPP participating in the DA market and providing reserve and flexiramp (ramping capability to handle the imbalances in real-time dispatch [111]), minimizes the flexiramp and fuel cost, maximizes the profit of DR aggregator from energy supply and downward flexiramp and minimization the penalty associated with the small-size consumers' non-alignment by the DR aggregator. The lower-level problem is focused on minimization of the energy, flexiramp, and reserve procurement cost while operating the network under constraints. A stochastic mixed-integer linear programming (MILP) bilevel model describes a balancing group of an aggregator of active prosumers and a WPP [112]. Upper-level describes profit maximization of the WPP and the aggregator acting as leaders in a Stackelberg game, while the lower-level models energy procurement cost minimization of prosumers acting as followers. Three pricing mechanisms for prosumers are modelled: ToU, dynamic prices set by the aggregator, and prices following market prices. Fig. 3 demonstrates energy and cash flow for an aggregator and flexible prosumers in Stackelberg game and WPP in separate and joint market participation. Black thick arrows represent energy and cash flow traded in the DA market (with total energy traded in black text and cost/profit in green text). Red arrows represent balancing cost that occurred due to imperfect load, PV and wind predictions. Dotted arrows are real-time energy exchange. Prosumers can either buy energy from the aggregator or exchange it for free with WPP. It has to be underlined that prosumers' flexible behavior serves as a BES to the WPP in order to reduce balancing costs. Total energy exchange at the end of the day has to be the same in both directions. In joint market

Table 2
Incentive-based DR.

Type of optimization	Reference	Type of DR	Methodology	Dimension	DERs	Location	Results
Commercial software-MATLAB Fuzzy Logic Toolbox	[54]	DLC	Mathematical model, design and implementation of fuzzy controller with different number and shapes of membership functions to maintain the comfort with less energy consumption	Annual energy consumption of conventional load 4482 kWh	AC	Not specified	25 % reduction of energy consumption
Commercial software-Java Agent DEvelopment framework	[55]	CL	Minimization of supply/demand gap in microgrids through virtual market enabling DR with a priority-based incentive mechanism	Two microgrids with 2 DG max power 160 kW and two loads max power 160 kW, storage 40 kWh capacity	continuous and discontinuous SL, CL, BES	Not specified	Decrease of load prices by 5% during the periods of electricity surplus due to energy exchange between microgrids and DR
Simulator in MATLAB	[56]	DLC	A control scheme for following load profile of VPP and maintain the comfort of final users with minimization of estimated temperature	1 and 96 3 kW domestic electric water heaters	3 kW domestic electric water heaters, WPP	pilot project PowerShift Atlantic in Canada	Weakly mean absolute value 6.5 kW for actual and simulated single domestic electric water heater
Power hardware-in-the-loop simulation setup in Simulink and LabVIEW	[57]	DLC	Simulation of real-time DR with BES and variable-speed heat pump and proposal of grid frequency regulation scheme	27 kW PV, 20 kWh BES	BES, PV, variable-speed heat pump 20 kW	LG Electronics Gasan R&D Campus, Korea	Smaller amount of FRR capacity with proposed method, improvement of frequency stability – peak-to-peak variations reduced by 48%
Direct optimization	[58]	DLC, deferrable, IL	Peak shaving with DLC to eliminate congestion and voltage deviations in three phase unbalanced LV distribution network	10-bus system with 0.95 MVA peak load	PV, washer, dryer, AC, lighting, plug load	Temperature data from Southern California	14 % peak load reduction, prevention of unallowed voltage deviation
	[59]	CL	Model of planned short-term CL with deterministic rolling-horizon look-ahead procedure (RH) and ADP procedures considering uncertainty	Primary 27 kV network with 24 substations, 725 transformers, 3562 cables, reduced secondary 120 V network with 3681 nodes and 4878	CL announced 2 hours in advance	Real and synthetic data for distribution network in part of a large city in USA	ADP more robust than deterministic procedure, but more computationally challenging
	[60]	IL, DLC, load as capacity resource	Integrated WPP and DR economic model minimizing total operation cost, fuel cost, startup cost, greenhouse gas emission costs, and DR cos with different level of DR penetration	200 MW and 50 MW rated power of WPP, with total DR capacity 166.2 MW-498MW	IL, DLC, and load as capacity resource	LMPs from NYISO New York City	200 MW WPP: Total cost reduction 1.3% -3 % with DR penetration 50 MW WPP: Total cost reduction 1.6% -3 % with DR penetration
	[61]	IL	Minimization of CL cost to eliminate the emergency station of transformer with different percentage of risk aversion to overload	IEEE 14-bus system, 100 MVA transformer, max peak load at bus 45 MW	IL, curtailment	Not specified	The best value for risk-cost ratio is 43% risk aversion
	[62]	IL	Minimization of economic dispatch cost considering operating reserve cost due to forecasted WPP errors using Markov chain-based model	IEEE RTS-1996, peak load 8550 MW	WPP, IL management	Wind data from NREL and Xcel Energy	Reduction of system cost by 1.73 %, 2.79 % and 3.59% with proposed approach with 10%, 20% and 30% of WPP penetration
[63]			A two-stage bidding approach for	800 consumers, 4 or 6 kW rated power of	H/C DLC		45.5 % peak load reduction with proposed

(continued on next page)

Table 2 (continued)

Type of optimization	Reference	Type of DR	Methodology	Dimension	DERs	Location	Results
		heating/cooling DLC (H/C DLC)	minimization of energy procurement in DA and minimization of deviation from actual load in RT using H/C DLC	heating/cooling device		PJM and Electric Reliability Council of Texas data	method, load aggregator 6.23 % cost reduction
	[64]	CL	Minimization of VPP cost with optimal exchanged power with grid under risk-based long-term and short-term maintenance schedule	IEEE 6-bus and 18-bus test systems	WPP, PV, BES, CL	Not specified	Decrease of energy losses by 22% for higher level of risk, 0.23% lower operational cost
	[65]	IL, SL	Integrated resource planning cost minimization in microgrid considering investment, peak clipping	Max load 221 kW, 33 kW WPP, 100 kW PV, 100 kWh BES, diesel generator 210 kW	PV, WPP, BES, IL, SL, diesel generators	Data from Shanghai, China	Cost reduction by 0.5% and by 0.4% for integrated resource planning and pure peak clipping model compared to the traditional planning
	[66]	IL, CL	Cost minimization of system operator and final user with three-interaction pattern DR program: direct CL, coupling of multi-energy demands and multi-energy interaction between supply and demand	47 MW electricity peak, 40 MW heating peak and 10 MW cooling peak	IL, flexible heating and cooling loads	south China	47% operator's cost reduction, 11.6% decrease of consumer's cost compared to conventional DR program
	[67]	CL, IL	Peak reduction considering CL and IL depending on price elasticity with penalty scheme for not providing committed service in capacity market program	3400 MW peak load	CL, IL	Iranian power grid	Peak reduction by 3-7%, energy reduction by 0.2-1.8%
	[68]	CL	Cost minimization of final user considering behavioral economics under different tests (rational consumer test, endowment effect test, discounting test and pro-social test)	Household 0.35 kWh max hourly consumption	10.2 kW electric heat pump	Not specified	Almost 4 £ reduction in the electricity cost with described tests compared to energy minimization policy during peak day
	[69]	CL, DLC, Emergency DR, IL, Demand bidding	Peak reduction, energy savings and cost reduction under different price-based and incentive-based DR including penalty for not providing reserve	3400 MW peak load	CL, DLC, Emergency DR, IL, Demand bidding	Iranian network load curve	Customer's bill reduction by 0.4% under DLC, peak reduction up to 6.17%, energy reduction up to 2%
	[70]	IL	Minimization of DR cost while reducing peak load and line loss	IEEE RTS 24, 2 MW peak	WT, PV, BES, IL	Not specified	Increased peak-shaving by 16.7% with 30.8% volatility reduction with proposed method
	[71]	CL, SL	Maximization of available transfer capacity with DR in a two-stage evaluation process with total cost generation	IEEE 14-bus system, 66.5 MV PV, 432 MW WT, 240 MW peak load	Deferrable, switchable load, adjustable load, WT, PV	Sichuan, China	Profit from selling interchange power increased by 5.18%, generation cost decreased by 34%, total cost decreased by 45%
ADMM	[72]	DLC	Definition and development of an optimal hierarchical load control in case of communication problems which	39-bus system with 10 generators (installed 10000 MW), load (installed 6150.50 MW),	Controllable load	New England	Reduction of communication links and improvement of decentralized strategy by 15% compared to the centralized

(continued on next page)

Table 2 (continued)

Type of optimization	Reference	Type of DR	Methodology	Dimension	DERs	Location	Results
			guarantees system stability in distributed optimization	controllable load 62.4 MW			
Centralized and decentralized optimization	[73]	DLC	Hybrid control method for reducing frequency detection error and communication latency in flexibility service provision from DR	10 000 flexible loads and 800 MW steam generator providing up to 16 MW regulation power	On/off flexible load (1 kW), continuously adjustable load (1.4 kW)	Hangzhou, China	Reduction of maximum frequency deviation by 97% and 7% compared to centralized and decentralized control
Iterative optimization	[74]	CL, deferrable	Minimization of consumer's electricity bill and load curtailment with automated demand response applying higher price signals when demand exceed a specific threshold	30 single dwelling with 16kW peak demand, 4 kW PEV charger, 2 kW oven, 3 kW hob, initial daily load 87 kWh	Oven and hob appliances as CL	Historical UK data for the coldest day in January	More than 50% electricity bill reduction with proposed approach, duration of exceeding the peak from 28% to 11.5%, improvement of load factor by 4%
	[75]	IL	Minimization of IL cost for providing primary frequency response	IEEE 118-bus test case study with 1000 IL units	load-shedding relay models	Not specified	27 % cost reduction with proposed approach compared to the base case
Bilevel optimization	[76]	IL programs	Upper level profit maximization of active distribution company strategically operating distribution network with market clearing as lower level	A 33-node distribution network connected with an 8-bus transmission network	IL, DG	Not specified	23 % of profit increase, increase of available IL from 10% to 25%, reduced voltage penalty
	[77]	IL, SL	Minimization of investment and system operation cost in upper level in long-term, daily operation cost minimization in short-term in lower level	AC 1.5 kW, washer 0.5 kW, dryer 1 kW, EV charger 5 kW, dishwasher 0.9 kW, WT max hourly production 300 kWh, PV max hourly production 225 kWh, accumulative max hourly load 450 kWh	PV, WT, controllable microgenerator, BES	Not specified	Decrease of charging and discharging frequency of BES by 16%-28% which result in longer life service
Machine learning	[78]	DLC	A two-stage complementary robust framework maximizing total microgrids' profit considering operation and maintenance costs of storage units, WPP and PV, transaction with main grid and customer loads and network constraints	2MWh BES, 3x 1 MWh BES, 2 MW WPP, 2x1 MW WPP, 3x0.5 MW PV	PV, WPP, BES	IEEE 33-bus distribution system	worst case scenario profit 9.4% lower with lower bound of uncertainty budget
	[79]	IL	DSO's cost minimization for the grid operation and activation of DR	3000 kW peak load before DR	IL	33 IEEE test network	Cost reduction by 31 % with proposed method compared to the no DR approach, voltage in $\pm 5\%$ range
	[80]	DLC, smart-IL	Minimization of power outages and peak-to-average ration using smart- DLC and load shedding	100 consumers with 5-15 appliances with 600 kWh max hourly consumption	Programmable appliance (shiftable working time), dimmable appliance (consumption increase/decrease), static appliance (on/off)	Not specified	33% of load reduction in peak hours with smoothed load profile curve
	[81]	CL, IL	Retailer's profit maximization determining the optimized prices for DR	9.9 kWh EV, 3.5 kW load peak	EV, non-interruptible and curtailable appliances	Not specified	Profit increase of a retailer by 11% compared to the base case
	[82]		Minimization of system operational cost and		PV, WT, BES, IL, transferrable load	ISO New England data	46 % operational cost reduction with

(continued on next page)

Table 2 (continued)

Type of optimization	Reference	Type of DR	Methodology	Dimension	DERs	Location	Results
		IL, transferrable loads	RES curtailment with DR and BES integration providing primary frequency response and dealing with post contingency frequency dynamics	39 bus New England, 118 bus IEEE test systems			integration of BES, DR and RES, RES curtailment decreased by 26% with BES and DR
	[83]	DLC	Cost minimization of buildings' operator under price-based DR using HVAC systems and BES using meta-prediction artificial neural networks	IEEE 123-Node Test Feeder, peak demand 7.04 MW	12 HVAC units at 15 buses with total power 195.8 kW at each bus, BES	Not specified	92% decrease of computational time compared to conventional approach, decrease of building cost by 30-39% with decreased maximum allowable deviations of bus voltages
	[84]	IL	Two-stage coordinated optimization with multiple objectives maximizing user benefits and satisfaction and economic returns of load aggregators	160.5 kW IL, 150,500 and 600 2.5 kW AC	AC, industrial load, PV	Eastern China	Coordinated mode increase the economic return by 2-9% and user satisfaction by 28-31%
	[85]	IL	Minimization of operational cost, not supplied energy and cost of interruptible EV charging to optimize spinning reserve requirements	2700 MW peak load without EV	EV 4.5 kW charging, 9 kW V2G	EV travel data from U.S. Department of Transportation Federal Highway Administration	Total cost reduction by 4 % with smart EV charging, V2G and possibility of charging interruption, 5.3 % cost reduction of not supplied energy, max 25% increase in scheduled spinning reserve
Heuristic	[86]	CL	Distributed algorithm for the dynamic microgrid's adoption to the changes in the power system with autonomous and independent DER optimization	3000 kWh BES, 1200 kW PV	PV, CL, EV, BES	PV output and load data from Northern California, price from CAISO	Reduction of load curtailment by 4.4% with ADMM compared to centralized approach, increase of PV curtailment by 1.9%
	[87]	CL, DLC	Selection of appropriate costumers for providing DR with 3 objectives: DR cost minimization, penalty minimization in case of DR failure, maximization of DR reliability for a multiple-hour event	25954 customers, 4000 (2000) kWh target energy savings for 2(1) hours	AC	Zone 13 in California Energy Commission, data provided from Pacific Gas and Electric Company	2668 customers are selected to achieve 2000 kWh energy savings for one hour
	[88]	CL	The proposal of load curtailment market approach to ensure voltage stability in heavily loaded power systems with power generation and curtailment cost minimization considering N-1 contingency conditions	IEEE 39-bus test system with max 1200 MW generator's capacity	PV, CL	Not specified	2.08% secured discount on the electricity bill for service providers , decrease of total power generation cost by 1.3% with proposed method compared to OPF solution
	[89]	DLC	Minimization of total deviations between scheduled and instructed shed AC and minimization of the final user's comfort disturbance solved with fuzzy adaptive	4450 kW shed load capacity, 15 423 kWh total amount of shed load in a day	AC	Data from Guangzhou Central meteorological observatory for Guangzhou, Shenzhen, Zhuhai	Decrease in average execution time by 10 % compared to genetic algorithm, decrease in average load difference associated with optimal scheduling solution by 22%-50% compared to other approaches

(continued on next page)

Table 2 (continued)

Type of optimization	Reference	Type of DR	Methodology	Dimension	DERs	Location	Results
			imperialist competitive algorithm				
	[90]	CL	The minimization of multi-carrier microgrid cost considering investment, operation, maintenance, energy demand shifting, monthly peak demand charge, emission, and reliability	Aggregated microgrid's electrical load 730 kW and 290 kW thermal load	PV (100-500 kW), WPP (100-500 kW), CHP (500-2500kW), auxiliary boiler (100-500 kW), BES (50-300 kWh)	Data from ISO New England and Henry Hub Natural Gas	7-23% peak reduction by DR, 112-131% cost savings
	[91]	IL	Reduction of compressor electricity consumption and market participation of AC as IL for DR	20 apartments with 68 ACs connected to 36 compressors	AC	Singapore	33 % reduction in power savings compared to the case without temperature control, interruption of 81.55 % in total consumed power without the comfort disturbance
Game theory	[92]	DLC	Centralized and decentralized approach in providing reserve with different level of information sharing and access to the cost assumptions	Maximum 40 MW up-reserve	DLC	Not specified	System operator cost increased by 1.2 % and 3.8 % in centralized and decentralized approach compared to the base case, consumer payments decrease by 80% and 77 %
	[93]	DLC	A cooperative game between a retailer and users under cost minimization with DR programs	One retailer with 5 users, AC 4kW rated power, EV charger 5kW, washer 0.6 kW	EV, washer, dryer, dishwasher, TCL, AC	Predicted Elbas' electricity prices	4% decrease of user's electricity bill, relative cost reduction of a retailer by 7.56%
	[94]	IL	Optimal dispatch of a single VPP and multiple VPPs considering DR and energy exchange between VPPs	3 VPP with 325 k, 200 kW and 200 kW peak load, max 125 and 2255 kW PV, max 150kW WT	PV, WT, BES, IL	Not specified	Coordination between multiple VPPs result in more flexible operation compared to the individual VPP dispatch

participation balancing costs are reduced for both aggregator and WPP and their profit is increased due to mutual energy exchange which enables better market positioning.

The work in Ref. [113] proposes the method for enhancing the utilization of wind power and reducing the energy costs of residential consumers and the operation costs of the power system. A smart home energy management system is proposed for minimization of consumer's electricity cost and one-third of residential prosumers are modelled as price responsive who follow the production of WPP which results in lower WPP curtailment. The joint operation of WPP and a large fleet of EVs considering BES degradation cost is proposed in Ref. [114] to counterbalance the fluctuations of the WPP in a three-stage

mixed-integer stochastic programming problem. Trading on DA, ID and balancing market is modelled showing a higher profit of WPP in the joint operation. The coordination between WPP and DR resources is modelled as a bi-objective mixed integer nonlinear programming to increase the expected WPP profit and the wind energy utilization [115]. The results show that the WPP purchases the flexibility from active prosumers clustered to provide DR during peak prices to mitigate the deviations of its own production and to sell energy back to DR prosumers at off-peak prices to achieve higher profit. A bilevel formulation of WPP offering strategy combined with DR programs is presented in Ref. [105]. In the upper-level WPP maximizes its profit, while the lower-level models the aggregator behavior through its revenue function. The results show that

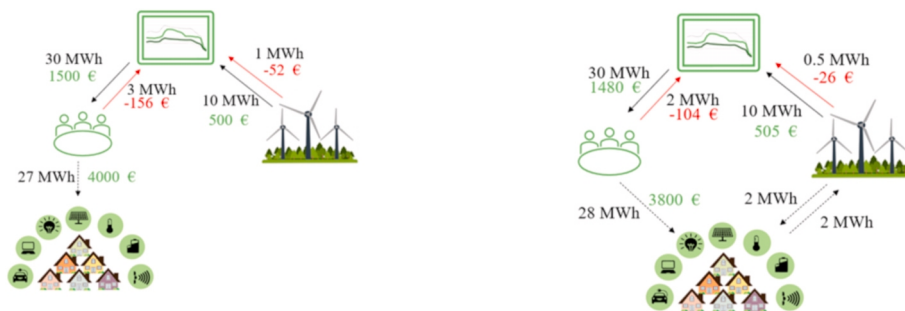

Fig. 3. Energy exchange and trading in balancing group [112].

when WPP acts as the risk-averse producer, WPP is not interested in trading DR service to sell it in the volatile market, but in the periods of peak market price, WPP can increase its profit by buying energy through DR contracts.

4.2. Energy communities and microgrids

On the other hand, different types of market entities focused on prosumers aggregation are energy communities and microgrids. Both of them can facilitate the local optimization of power flows and improve the quality of service with the reduction of energy losses, postpone or reduce network investments by increasing hosting capacity and improving flexibility through AS offers for more efficient system operation. They can be self-responsible for balancing their portfolio and are responsible to ensure quality and security in energy supply to all members with reduced network and electricity tariffs due to the aggregation effect [116]. Local energy allocation can result in a reduction of peak demand and a decrease in power flows from the main grid. It has to be emphasized that the main difference between energy communities and microgrids is that energy communities are not designated to operate in an island mode.

The paper [117] gave a comprehensive review on energy communities regarding new governance model for energy communities under the European Union Renewable Energy Directive (RED II) and Internal Electricity Market Directive (IEMD) describing the different perspective of both directives in eligibility, primary purpose, membership, ownership and control. The paper assessed 67 best-practice cases of consumer (co-)ownership from 18 countries using the criteria of cluster potential, heterogeneity and governance and ownership criteria set by Directives. Only 5 cases meet all mentioned criteria. The main sources of flexibility in the system can be provided from both supply and demand side, energy storage and energy conversion, but also from grid interconnection. Energy storage in the community can be of three types, shared residential, local, and virtual energy storage. The paper [118] gives a comprehensive review of energy storage applications in the energy community. Energy storage in the community for arbitrage and arbitrage with peak shaving under dual ownership (aggregator and DSO) was described in Ref. [119]. The energy share in the local energy community is not limited only to electricity. In order to lower their carbon footprint, community members can also exchange energy for heating and cooling and use different types of storage (BES, hot and cold thermal storage) and CHP, PV, gas boiler, electric chiller, and gas engine [120]. The use of flexible resources can lead to an undesired peak just before the starting of the DR program in order to e.g. preheat the room to ensure lower consumption when requested [121]. The penetration of PV and optimal sizing of BES storage systems in the energy community is strongly related to the investment cost, but also to other devices installed in the community [122]. With more heat pumps and CHPs in the community, optimal BES capacity is lower. Moreover, different prices of storage units affect BES storage behavior. BES storage with a lower price smooths the load curve to zero during the period of high electricity prices, while BES storage with a higher price shaves the load in some hours.

The installation of low-carbon carbon technology results in lower fuel consumption, terrestrial and water toxicity. Off-grid and hybrid households and community microgrids equipped with BES, PV, and WPP can be sustainable without the backup power of diesel generators [123]. As the number of RES is increasing, prosumers who inject their excess of PV generation in the grid will be progressively grouped in energy communities to share the energy locally. Coordinated charging of EV and DR programs can significantly reduce the cost of energy community hub [124]. In order to increase the profit of the microgrids together with the reliability and consumers' satisfaction, microgrids can interconnect and exchange energy among themselves and the upstream grid by optimizing their assets [125]. The energy storage can be either private property or part of the energy community [126]. The surplus of PV generation injected in the grid is lower, and thus self-sufficiency is

higher with a lower rate of investment return when the storage is a community's property. Unlike uncertainties in RES production, the electricity price and the cycling cost of the BES (BES degradation) have a significant impact on a BES schedule. The microgrid with RES and energy storage can save up to 91% of the operating cost compared to the microgrid without any low-carbon technologies [127].

There are two types of energy community management and control: centralized and decentralized energy community trading. In a centralized approach the community manager or microgrid central controller schedules flexible devices based on DLC, while in a decentralized approach the household energy management system schedules the consumption based on price signals. In a decentralized approach, home energy management system and microgrid central controller agree on the energy price and scheduled consumption or generation [128]. Profit-sharing between all communities' members should be fair. The most beneficial situation is a grand coalition which ensures the highest payoff for all community members together with peak shaving and valley filling [129].

The local energy community can opt for cost minimization for both electricity and gas and provide a reserve to the system [130]. It is important to ensure that providing flexibility to the system does not harm end-user's comfort. As opposite to centralized coordination of energy community, a distributed model based on alternating direction methods of multipliers is also appropriate for blockchain technology for safe energy exchange with limited information communication [131]. A two-stage algorithm calculates the power loss for each prosumer and then total power losses for the community are recalculated based on all transactions. The cooperative model of an energy hub increases the profit of a hub manager, enhances local energy sharing and reduces consumers' costs [132]. Cooperation is divided in cooperation between hub manager and prosumers (hub manager proposes attractive prices of energy from combined cooling, heating, and power generation to compete with utility's prices) and prosumers between themselves (excess PV production).

A two-stage model minimizes the DA operation cost of the microgrid in a centralized manner, while RT deviations from the predefined DA schedule are reduced with the usage of BES in a dynamic distributed approach [133]. The benefit of decentralized RT dynamic compensation is a faster computation time. Competition between buyers in the energy community and price competition between sellers bring technical and financial benefits to community members [134]. The energy trading is modelled as bilevel problem with a Stackelberg game with sellers as leaders and buyers as followers. The upper-level problem of [135] is an integrated energy community system that schedules PV and energy storage units in the interaction with the market, while in the lower-level prosumers are minimizing their energy bill. In order to maximize its profit, the energy community system determines the optimal size of PV and BES. The prices for energy exchange between energy community systems and prosumers are determined based on bilevel formulation. The bilevel formulation in which community energy management system is a leader and home energy management systems are followers is proposed in Ref. [136].

The model of a dynamic optimal contract between the aggregator and EVs is based on blockchain technology to ensure a secure charging of EVs [137]. The price difference for buying and selling energy encourages prosumers and consumers to form an autonomous energy community and trade energy internally. The internal prices for energy trading are determined based on Shapley value [138] or demand vs-surplus ratio [139] and are more beneficial than buying and selling prices from the grid. The integration of a high number of EVs can serve to relieve the peak-load in the energy community while minimizing the cost of power generation and pollutant emissions and increase the stability of the energy supply [140]. A resilience scheduling strategy of integrated electricity and gas community energy system with a storage reserve is divided into three steps: rolling optimization stage for the reserve capacity, DA scheduling stage, and fault restoration stage [141].

Table 3
Energy community's characteristics.

Type of optimization	Reference	Methodology and prices calculation	Dimension	Location	DERs	Results
Direct optimization	[133]	MINLP model which minimizes OPEX cost, fuel cost, operational and carbon cost in multi-energy community	District with 2.6 MW electrical power peak and 10 MW heat power peak	real multi-vector district at the University of Manchester, electricity and heat network data from COHERENT	PV, BES, heat pump, gas boiler, thermal storage	With increased carbon prices, heat pump becomes less advantageous option, use of CHP decreases PV self-consumption rate (SCR), while heat pump increases SCR and battery arbitrage revenue
	[137]	Economics of storage adoption with high PV penetration and high electricity cost in individual and community ownership	4500 individual households in 200 communities with 3244 MWh monthly consumption and 851 MWh PV production	Cambridge, MA	PV, BES owned by household or community	The optimal size of community level BES is 65% of total size of individual units, each kWh of community battery is 64–94% more effective at reducing exports from the community
	[141]	Stochastic MILP model of gas/electricity procurement and imbalance cost minimization with profit maximization from providing reserve	A district with 100kW peak	UK energy and reserve prices used on synthetic district	CHP, EHP, electric boiler, gas boiler, BES, RES	Case studies with EHP reduces costs more compared to cases with gas boiler, installing battery reduces cost due to payoff from the DSO
	[144]	A two-modules energy management strategy (EMS) for operational cost minimization of microgrid community	4 wind turbines 3.2–4.3 kW, 4 PV 3.2–2.5 kW, 4 loads 0.082–4.6 kW	real lab-scale microgrid experimental platform in Guangdong, China	PV, wind, BES	Cost reduction of proposed EMS is reduced by 50% compared to the case without EMS, proposed EMS is 75% faster
	[152]	A two-level planning approach for minimization of investment and operation cost, load curtailment cost and cost of purchasing energy and natural gas	1000 kWp PV, 8500 kW peak in cooling period and 7500 kW peak in heating period	China	PV, heat pump, conventional water-cooled chiller, ice-storage system, electric boiler system with accumulator, gas turbine, absorption chiller	Improved reliability for a cost-increase by 1.4%, increased level of supplied load by 11% with proposed methodology
	[135]	Robust load dispatch optimization model in energy hub considering CO2 emissions, operational and maintenance cost, buying and selling price with electrical and thermal DR	Energy hub with 300 EV with 30 kWh battery capacity, heat storage unit 1000 kWh, max electrical peak in the community 300 kW and thermal peak 175 kW	Not specified	CHP, gas boiler, heat storage, PV, WT, EV, electric and thermal DR	coordinated EV charging/discharging reduces the total cost by 6.61%, 4.38% additional cost reduction with DR implementation
ADMM	[153]	Optimization of energy flows in microgrid using OPF with bilateral trading decomposed with ADMM for distributed optimization	22 households in the community with weekly energy exchange from 500–1000 kWh during summer and up to 2500 kWh during winter	Real prosumer community in Amsterdam	EV, PV, battery	Combined OPF and bilateral trading reduces the community cost by 35% compared to either individual OPF approach or bilateral trading approach, peak import quantity is reduced by 60%
	[139]	Multi-objective function: cost minimization, unallowed voltage drop minimization, losses minimization in distributed, privacy-preserving microgrid solved with ADMM	20 houses with a 5 kW HVAC installed, 100 kWh storage, 50 kW PV, DG size 60kW and 30 kW and scaled system with 100 houses	Oak Ridge National Laboratory microgrid test system	PV, battery, HVAC, DG	Distributed optimization decreases computational time by 92% in islanded and 94% in grid-connected case compared to centralized operation
	[142]	DA operational planning of energy community solved in distributed manner with ADMM to secure prosumer's confidentiality	Energy community with 2LV feeders and 10 members with 15–32 kW peak, battery size 1–6 kWh, 14–42m ² PV panel surface	Not specified	RES, battery	Very similar results compared to the centralized approach Cost reduction decreases by 4%–72% compared to the case without internal energy exchange
Game theory	[140]	Coalitional game optimization model with a fair payoff distribution scheme for all members	9 households with a peak fixed load 0.55 kW and PV output 9 kW	Typical UK fixed load data from UKERC Energy Data Centre	EV, PV, battery, flexible load	Nucleus-based solution fairly distributes total payoff, grand coalition increases the global payoff and beneficial impacts peak shaving and valley filling
	[143]	Cost minimization of energy hub members with cooperative and non-cooperative game theory	Two office buildings and four residential buildings with 160 or 200 kWp PV capacity	Not specified	PV, DR, of combined cooling, heating and power generation (CCHP)	4% cost reduction with cooperative mode compared with non-cooperative mode with DR, increased profit by 83% for hub manager in the

(continued on next page)

Table 3 (continued)

Type of optimization	Reference	Methodology and prices calculation	Dimension	Location	DERs	Results
						cooperative mode compared to the profit of CCHP manager
	[145]	Game theory model for p2p trading in the energy community with price competition among sellers and seller selection competition among the buyers	5 prosumers in the community, two 20kWh batteries	Prices are based on actual electricity prices in Singapore	PV, battery, DR	Community cost is reduced by 4.5% compared to the BSM, MMR and SDR method
	[148]	Smart contract for EV charging based on blockchain technology, reputation based delegated Byzantine fault tolerance consensus algorithm	100 EVs with 25kWh capacity, 100kWh battery capacity	Not specified	EV, PV, battery	Double profit increase of aggregator under proposed pricing scheme compared to flat and two-part tariff scheme
	[149]	Cost minimization of community members without a central controller based on a Shapley-value energy contract	7 kWh energy storage, aggregated community peak 50 kW and PV 33 kW	Electricity prices from Austin Energy, Texas, USA	PV, battery	Energy cost savings by 23.35%, 1.16% reduction of power fluctuation
	[150]	Pricing mechanism for community pool based on demand-vs-surplus ratio to maximize the consumption from RES	Battery 13.5 kWh, max consumption up to 0.5 kWh in 30min, 8kWh solar production in 30 min period, 1 smart user and 4 non-intelligent users	real-time retail price data from the British electricity retail market	PV, battery	smart user has 50% lower cost compared to the non-intelligent user, smart user has 25% lower cost with proposed algorithm compared to the case without it
Bilevel	[146]	Stochastic MILP bilevel optimization, prices determined based on prosumers' trading with market and integrated energy community system	3 prosumers with 0.7 MW peak before optimization	Generic domestic demand data from Spain	PV, battery	Smart prosumers achieve lower electricity cost with integrated community energy system compared to passive prosumers
	[147]	Bilevel optimization modelling interaction between HEMS and CEMS with a goal of facilitating energy sharing between community members and minimization of the grid outage	Energy community with 4,10,20,30,100 and 2000 households with 4.5 kW peak, community storage 20,40,60,18,360 kWh	Not specified	Battery, non-interruptible and interruptible controllable appliances	Decrease of unserved load from 30.71 kWh to 3.32 kWh (90%) during grid outages for a 4-home community, 84% for a 10,20,30-home community, 62% for a 100-home community and 50% for a 200-home community
Heuristic	[138]	Particle swarm optimization, electricity cost minimization with BES degradation cost	Community with 15 households, 40 kW wind generation, 35 kW PV, 40 kWh battery	Not specified	PV, battery, wind	Reduction of operational cost by 40% compared to baseline model, reduction of operational cost by 91.57% compared to the case without RES and storage, and 48% compared to the case with only RES
Commercial-software based	[134]	Life cycle assessment using HOMER Pro software to determine the life cycle environmental impacts of continuous electricity supply by energy systems independent from other networks in remote rural areas	21 home (daily consumption 8.2 kWh) and community microgrid systems with PV 1.29 to 3.45 kW, 5kW wind turbines	Remote rural tropical area	Hybrid solar-wind system, battery, diesel generator	BES reduces environmental impact of diesel generator by 20-30%, PV systems have 15% higher impacts in a micro-grid compared to homes, hybrid PV-wind systems with BES have 17-40% lower impacts compared to the equivalent stand-alone installations per kWh generated.

This optimal operation method results in enhanced system resilience with a guarantee of sufficient reserve capacity.

The energy trade between prosumers can be based on p2p trading mechanisms or only fairly sharing the cost of the entire community between the members. P2p trading mechanisms are the result of self-interested community members whose purpose is only a financial benefit. The most profitable approach is a simple energy community without trading mechanisms in which members share the local energy surplus leading to maximal social welfare, although including network constraints in the calculation reduces peak imports and grid import costs [142]. The overview of price calculation mechanisms and DERs participating in energy communities in described literature is given in Table 3:

5. Opportunities in peer-to-peer trading

Traditional consumers are characterized by passive consumption without any willingness to change their behavior patterns. With the lower investment prices of PV and BES, consumers are becoming prosumers and can flexibly manage their consumption and production. Energy exchange between final customer arises as an alternative or additional option in energy trading which brings multiple advantages, such as fair and secure trading, energy does not have to be transported from centrally located power plants which reduces electricity transportation costs, energy is bought from a known source (according to consumer's preferences), total freedom of choice and autonomy, which empowers the active consumers and potential new services for grid operators provided by the community manager [11]. Although p2p trading is not widely commercialized due to immature and not regulated market solutions, it represents an advanced option in the transition towards carbon-neutral power systems. In Ref. [17] authors described the benefits of energy communities in the UK, Germany, and the USA. The benefits are divided into seven categories, such as economic benefits, education, climate protection, innovation, etc. The paper also highlighted the barriers in forming energy communities: organizational issues, legal framework, lack of institutional and political support, lack of resources and expertise. The energy synergy between residential, commercial, and public buildings is investigated in Ref. [143] to exploit the profitability in different energy sharing concepts and investment decisions. Two forms of energy contracting are considered: energy performance contracting with a goal of energy system optimization with guaranteed energy savings, and energy supply contracting in which the contractor is responsible for the planning, financing, construction, operation, and maintenance. The results show that energy costs for residents in different business cases are decreased up to 12% in the energy community compared to the base case. A review paper focused on different aspects of p2p energy trading in electricity networks is proposed in Ref. [144]. The paper described network elements in p2p trading in the virtual and physical layer, communication infrastructure, market participants and regulation, an overview of market structure (fully decentralized markets, community-based markets, and composite markets), an overview of existing challenges and technical approaches. Our paper focuses on a review of different technical approaches in p2p trading.

In order to minimize the information flow between energy resources and local home energy consumption scheduler, game theory models, based on blockchain technology, is emerging as an interesting and safe solution for cost-sharing among community members in the centralized operation of energy community with the goal of cost minimization and peak shaving during the periods of peak demand [145]. A coalitional optimization of smart prosumers can reduce their electricity cost when compared to individual trading and energy scheduling [146]. Moreover, if the electricity is shared among community members who are not flexible and do not own generation onsite, both sellers and buyers can profit from the coalition. The cost (profit) of community members is fairly shared based on Shapley's value. Energy can be shared among

buildings based on a non-cooperative game with a cost reduction ratio in which all buildings can achieve lower energy costs with a smoother net demand profile [147]. Authors in Ref. [148] present electricity and heating trading between commercial (business area with a shopping mall, a hotel, and an office complex) and residential prosumers (a group of 2000 households) based on Nash-type non-cooperative game in two approaches: one considering fairness and the second one not. As the commercial prosumer has installed the larger onsite generation, electricity is usually sold by commercial to residential prosumer. The work in Ref. [149] serves as an introduction to p2p trading in South Korea. It determined a range of minimum trading price for prosumer and maximum trading price for a consumer beneficial for p2p trading. Prosumers can choose if they want to use their batteries in p2p trading and switch a coalition during the day in order to achieve a more beneficial position [150]. A bilevel model for p2p trading considers price-driven buyers in the lower-level and sellers in the upper-level [151].

Different goals in p2p trading are investigated in the literature. A p2p trading between prosumers without BES is described in Ref. [152]. CO₂ reduction and final customers cost is compared to the FiT case without p2p trading and results show higher CO₂ reduction during sunshine hours and lower electricity cost during representative summer and winter day. A detailed motivational framework describes how education leads to a positive attitude about p2p trading which encourages prosumers to join and continue participating in p2p trading. Prosumers can choose between three types of trading [153]. If the prosumer has a special requirement, bilateral negotiations with other prosumers result in long-term contracts. If there are no specific preferences, the continuous double auction mechanism for normal RT p2p trading is performed. If some bids are not traded locally, they will be directly passed to the global market for unified purchase and sale with the provider. Detailed profit analysis of the different sizes of rooftop PV in p2p trading shows that households with PV and BES achieve maximal savings when PV systems are large. If the installed PV system is smaller, it is more beneficial not to install a BES and these households will gain more profit when FiT is low. Moreover, households with PV systems have higher savings when the PV penetration in the neighborhood is low because high penetration of PV lowers the clearing price and thus the profit of the individual households [154]. A p2p trading in platform "ElecBay" in LV network is described in Ref. [155]. With p2p energy trading, the overall energy exchange between the observed microgrid and the grid is reduced, but if peers have installed similar low carbon technologies, the reduction of total peak load is small. On the other hand, if peers with various technologies trade between themselves, higher benefits are achieved (higher peak load reduction, a better balance of local generation and demand, and higher reduction of total peak load).

The performance of p2p trading in Ref. [156] was evaluated through economic indexes (value tapping, participation willing, and income equality) and technical indexes (energy balance, power flatness and self-sufficiency). The results show that Supply-Demand Ratio (SDR) has the highest value of both economic and technical performance index, while Mid-Market Rate (MMR) is slightly worse. On the other hand, the performance of Bill Sharing (BS) is more comparable to conventional trading without any p2p energy exchange. A p2p energy exchange in the ECO-Trade algorithm is divided into 3 modules (demand and generation calculation for each household, determination of microgrid energy price, determination of p2p traded energy) and demonstrates the cost reduction under p2p trading with different percentages of storage and PV integration [157]. The cost is decreasing with higher penetration of PV and BES up to the saturation point after which too much energy is produced and cannot be stored (wasted energy). However, the amount of wasted energy is always smaller in the microgrid with p2p trading compared to the case without internal energy trading. A two-stage p2p bidding strategy in Ref. [158] consist of an energy determination stage (before each trading period households receive the information about the hourly-ahead generation and load and decide on the amount of trading energy) and the price determination stage (the price range is

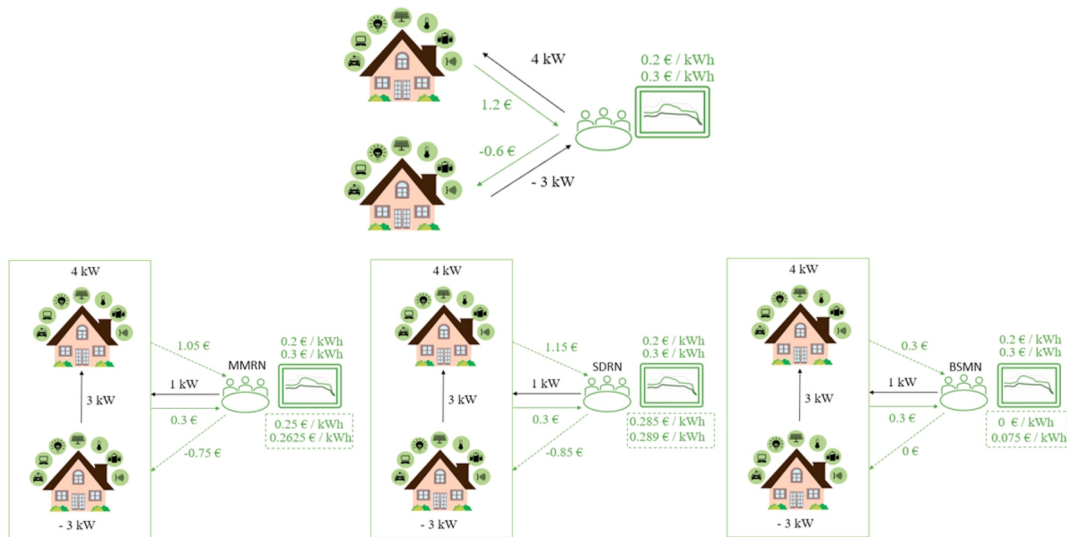

Fig. 4. Comparison between individual supplier-prosumer trading and different community pricing schemes.

determined considering risk hedging tool VaR). The results show increased social welfare using this approach with a higher amount of energy consumed locally instead of exchange with utility. Thermal loss and generation cost minimization is achieved with rescheduling DERs and shapeable loads [159]. The algorithm for p2p trading is established in two steps designing the local incentives which encourage users to participate in the crowdsourced energy system. The first stage gathers the DA predictions which are implemented in the second stage of market mechanisms.

In forward markets, prosumers, generators, and suppliers buy or sell energy contracts based on predictions of net demand and energy prices [160]. In the RT market they have to meet their obligations defined in forward markets through upstream and downstream contracts. Two-sided platform pricing strategies aim to design prices in order to maximize aggregator profit and consumer satisfaction through satisfying monetary benefits [161]. Results show that double-sided auctions are more profitable than continuous trading. Seller and buyer satisfaction indexes are higher in double-sided auctions which yield to consumers who are more motivated for p2p trading. P2p trading based on blockchain technology in a virtual power plant (VPP) was described in Ref. [162]. The trading was performed on the public Ethereum network to ensure transparent market procedure in inter-WPP and intra-VPP trading. Actions are controlled by a p2p energy trading coordinator who is responsible for investment, revenue collection, AS provision, etc.

A fully decentralized p2p trading compares different scenarios distinguishing cases with and without losses and network fees [163]. The results show that consumers' decision depends on prosumer's cost, but also on electrical distance from the producer. P2p trading reduces energy losses due to shorter electrical distances and also greenhouse gas emissions [164]. Consumers and producers in a non-cooperative Stackelberg game achieve higher benefits compared to conventional p2p trading characterized by a lack of information exchange. Power pocket trading protocol is divided into three steps: registration (energy subscribers register either as a demander or a supplier), auction (a demander bids for power pockets from a supplier or from the grid), and transmission (energy delivery) [165]. The controller decides the power pocket schedule. P2p trading between EV charging stations and office buildings brings additional savings compared to energy exchange only with the grid [166]. If PV production exceeds the total load of the office building, the excess energy is sold to the charging stations, while in case of insufficient PV generation, the energy demand of an office building is supplied from EVs with lower electricity prices compared to the utility price. The paper [167] proposed a two-stage energy cost-sharing in the

community which guarantees that all community members will be better off in the community compared to the traditional supply-consumer contracts. The prices are calculated ex-post, i.e., outside the optimization algorithm which makes it simple and fast to solve. Fig. 4 illustrates the energy and cash flow in traditional trading when each consumer signs a contract with the supplier and community trading. The full black line represents an energy flow in RT, while the full green line is a cash flow in RT. Dotted green lines in community trading are cash flows calculated ex-post for each community member. Due to different prices for buying and selling energy (0.2 €/kWh for selling and 0.3 €/kWh for buying), the energy exchange between community members arises as an alternative solution in energy trading. Buying and selling prices in the community are calculated ex-post based on net-load measurements of each community member and supplier's prices. They are shown in a dotted green box for each trading mechanism. It can be seen that lower prices occur in MMRN and SDRN making each community member is better off in the community. On the other hand, prosumer with excess PV production in BSMN is not paid for their energy excess which shows that this pricing method is not favorable for community trading.

A centralized power system increases the energy price when the demand exceeds the predefined threshold due to the management of reserves or starting more expensive units. This price increase encourages prosumers to participate in p2p trading which yields to lower operating costs of the system and lower costs for prosumers [168]. Bilateral p2p energy trading in Refs. [169,170] maximizes the social welfare of prosumers, while the algorithm ensures that network constraints are not violated. P2p market in Ref. [171] distinguishes two types of transaction goods (PV owners sell a surplus of PV and PV owners buy regulating capacity from consumers with flexible resources). The market operator matches load demand to PV forecast power and load regulating power to PV uncertain power. The pricing mechanism is based on the pay-as-bid principle. The benefits of forming a coalition for p2p trading are demonstrated in Ref. [172]. The work proves that the proposed formation of cooperation is stable and p2p energy trading between peers in the cooperation is consumer-centric and brings financial benefits to each coalition member compared to the FiT scheme. An algorithm for proposing an optimal path between prosumers and prosumers matching algorithm is proposed in Ref. [173]. Moreover, the algorithm for an optimal path for energy transfer can be used for congestion management in the distribution network. Besides internal p2p trading which ensures more beneficial prices for community members, energy communities can achieve an extra profit from participating in AS provision [174]

Table 4
Different technical approaches in p2p trading.

Reference	P2p trading mechanism	DERs
[145]	Cooperative game, flat rate, TOU, CPP, RT pricing	RES, flexible household appliances
[146]	Allocation of cost savings based on Shapley value	RES, BES
[147]	Non-cooperative game, cost reduction ratio distribution model	RES, HVAC, BES
[148]	Nash-type non-cooperative game with McCormick Envelopes relaxation and piecewise linearization	Dishwasher, washing machine, water heater for bath, EV, BES, cooling, and heating storage
[149]	Based on monthly electricity consumption and electricity to be traded between peers	PV
[150]	Coalition formation based on Pareto order	PV, BES
[151]	Stackelberg and non-cooperative game, Nash equilibrium and Rule-based Iterative Pricing	PV, BES, DR
[152]	Canonical coalition game with motivational psychology framework based on mid-market rate	PV
[153]	Bilateral negotiations, discriminatory continuous double auction	PV
[154]	P2p reservation purchase and sale prices based on desired and p2p traded margin and retail price and FIT	PV, BES
[155]	Non-cooperative game	Flexible demand, BES, EVs, PV, WPP, CHP, micro- turbine
[156]	Heuristic MMR, SDR, BS with step length control and learning process involvement, and a last-defence mechanism for convergence check	PV, EV
[157]	ECO-Trade algorithm based on a bilinear programming approach	PV, BES
[158]	A two-stage bidding strategy with price prediction and game-theoretic trading approach	PV, BES, EV, controllable load (IL and uninterruptible load)
[159]	Blockchain platform IBM Hyperledger Fabric	PV, BES, shapeable load
[160]	Bilateral contract networks with forward and RT markets	PV, flexible load
[161]	Double-sided auctions (percentage basis, flat fee, net listing, discriminatory pricing)	PV, WPP
[162]	Auction-based bidding model using smart contracts	RES, EV, BES, diesel generator
[163]	Social welfare maximization in a fully decentralized market	Consumers and producers
[164]	Stackelberg game	Prosumers
[165]	A power packet trading protocol with an iterative auction game	BES
[166]	Dynamic pricing mechanism	PV, EV
[167]	Ex-post MMRN, SDRN, BSMN	PV, EV, flexible thermal heating and uninterruptible appliances
[168]	Cooperative Stackelberg game based on a double-auction	PV
[169]	Fully decentralized bilateral trading based on algorithm using primal-dual gradient method without interaction of any central entity	PV, WPP, BES
[170]	Continuous double auctions	PV, BES
[171]	Unilateral auction mechanism	PV, EV, BES, SL (washing machine, water boiler), electric heater, thermostatically controlled loads
[172]	Canonical collation game with mid-market rate pricing	PV
[173]		Prosumers, consumers

Table 4 (continued)

Reference	P2p trading mechanism	DERs
	Modified physarum algorithm for energy network optimization, slime mould algorithm and a Hungarian matching algorithm for prosumers matching	

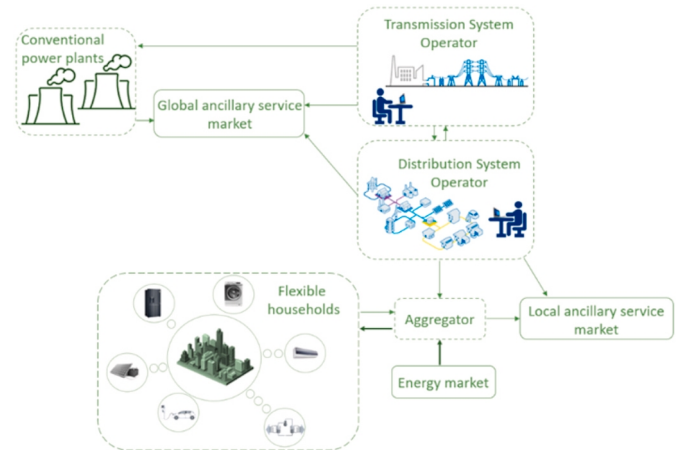

Fig. 5. Coordinated AS provision from the DER side and conventional power plants.

which will be described in the following Section.

Table 4 lists p2p energy trading mechanisms in described papers together with low carbon technologies used in trading.

6. Ancillary service provision from prosumers' side

Traditionally AS were provided by conventional power plants connected to the transmission network. Nowadays, with broader integration of RES characterized with intermittent production, the focus is put on providing AS also from distributed resources. DSO is responsible for distribution network planning and operation. In the smart grid environment, the role of the DSO is extended to the management of flexibility and infrastructure for electric vehicles (EV), improving energy efficiency, management of metering devices and data [175]. In the line with clean energy transition which emphasizes the importance of final customers and their active involvement in the power system with already explained benefits of flexible prosumption, aggregation and p2p trading, the focus of this Section is put on providing AS from resources connected to the distribution grid through DR programs and participation of aggregated flexible consumers in local and global AS markets coordinately managed by TSO and DSO.

A recently published review paper describes AS market on the distribution level and identifies technical, regulatory, and financial barriers in AS provision from the DER side [176]. To overcome the issues regarding providing flexibility from DERs, it is important to enable market participation of aggregators, extend roles of the DSO and efficiently design local flexibility markets [177]. A detailed review of flexibility products (TSO balancing, TSO and DSO congestion management, TSO and DSO power quality control, DSO voltage control, etc.) and market mechanisms for transmission and distribution level can be found in Ref. [178]. A comprehensive review [179] classifies DERs in the context of providing flexibility services (consumers, producers, bi-directional DERs), describes markets in which DERs can participate (AS markets, markets for balancing and congestion management, spot wholesale and capacity markets) and incentive mechanisms for providing services (DLC or price-based). Local flexibility markets can be formulated in a centralized manner with social welfare maximization or

operational cost minimization, as simulation models with multiple agents or game-theory (noncooperative and cooperative games) and auction theory-based models (single and double-sided) [180].

The idea of providing non-frequency AS and congestion management from locally connected resources emerges as an alternative solution to network reinforcement. Usually, DR programs were initiated by the TSO, but due to the wide installation of smart meters, an increasing number of EVs and solutions for flexible behavior from the end-user side, the local AS markets serve as a potential solution for purchasing available local flexibility in the distribution grid. The main idea of providing AS from the DER side in the future market environment is shown in Fig. 5. Firstly, the aggregator purchases energy for their portfolio (shown with dark green arrows). In the second step, it bids on the local AS market for solving local congestion or voltage problems. DSO purchases the flexibility from the local AS market and in coordination with the TSO submits the remaining bids on the global AS markets together with conventional power plants connected to the transmission level. Once the markets are cleared, systems operators send the activation signal to AS providers.

6.1. Diverse options for local flexibility provision

Three different schemes in contracting flexibility are analyzed in Ref. [181]. The first scheme refers to contracting flexibility in existing DA, ID, or balancing markets. Local congestion can be either solved in the first step and then in the second step the system balance is found, but also reverse order is applicable. The second scheme implies a new local market for local flexibility trading to solve balancing at the distribution level. In the third scheme flexibility is contracted as a system reserve. The decentralized local market for distribution level flexibility trading is described in Ref. [182]. The DSO procures flexibility in the DA market for expected congestion considering the uncertainty of demand and also reserves a specific volume of AS for congestions with medium probability. In the RT the DSO can procure flexibility for unexpected congestion. The design and implementation in the laboratory of a local flexibility market are described in Ref. [183]. Disconnectable and SL, curtailable (reducible and disconnectable) generators, and batteries offer their flexibility to the DSO to solve problems in the distribution grid which are reflected through the requested increase or decrease in active power. The local flexibility market model developed in the project UNITED-GRID [184] clearly defines the roles of market participants and market principles (market models and operation, trading and clearing mechanisms). Long-term, short-term, and RT markets are driven based on the future state of the grid detected by the DSO. Reservation and activation fees are remunerated, while the activation price is cleared-based. The profit maximization of EV aggregators through participation in the balancing market is described in Ref. [185]. The aggregators bid for regulation power, while the DSO checks if network constraints are violated. Aggregators modify their schedules until the network problems are solved. The coordination of DSO and EV aggregators brings benefits to both sides (lower energy procurement cost for EV charging together with the reduction of RES curtailment and the reduced difference between peak and valley energy consumption). Such coordination described in Ref. [186] using decentralized approximate dynamic programming-based transactive energy control tackles the uncertainties and computation complexity. The dual decomposition technique for providing flexibility to the DSO from the aggregators of residential users is demonstrated in the project RENnovates [187].

A decentralized market in which DSO purchases flexibility from competing aggregators is proposed in Ref. [188]. To achieve a better market position, aggregators have to incentivize their prosumers to provide flexibility. The proposed decentralized market can be integrated into the existing retail electricity market, while each entity involved in providing flexibility negotiates about the volume and price until a satisfied agreement for all parties is reached. A decentralized market framework for local scheduling of flexibility in ahead and RT markets as

bilevel optimization model is proposed in Ref. [189]. In the upper-level the DSO minimizes the cost of procuring flexibility in the market, while in two lower-levels DA and ID markets are cleared and flexibility volumes are determined. A local market framework for providing reactive power support from EVs is established in Ref. [190]. If EVs are engaged in reactive power support, more EVs can be integrated into the system without additional network upgrades. A realistic and fully functional local flexibility market was developed under the project EcoGrid 2.0 [191]. Two types of services are defined, namely capacity limitation services and baseline flexibility services which can be scheduled (activated regularly) or conditional (activated when necessary with reserve and activation fee).

Several papers focus on providing flexibility from an aggregator's point of view who participates in the local flexibility market to increase their profit. The aggregator of smart homes is in control of consumers' PV, thermal and electro-chemical storage and deals with uncertainty in prices, PV production, and demand [98]. The aggregator determines the energy schedule of their portfolio and the DSO checks if the distribution network constraints are violated. If flexibility is needed, the aggregator reschedules their portfolio regarding the DSO needs as part of bilateral transactions. Additionally, the aggregator can offer extra flexibility on the local flexibility market. The aggregator can be in charge of the market operation to monitor flexibility transactions in the local energy community [192]. The grid status can be green, amber, or red identifying the security of operation. The DSO identifies the grid state and notifies the aggregator. Prosumers can choose between ToU optimization, kWmax control, self-balancing, or controlled islanding. The results of IDE4L project established a communication approach between the DSO and an aggregator of DERs stimulated with dynamic prices and also control signal from an aggregator to solve congestion issues and voltage problems in the distribution network [193]. System operator formulates prices for flexibility, combines them with fixed price components (taxes, fixed cost) and sends them to the household energy management system which is in control of appliances in the household [194].

An increasing number of EVs has a significant impact on the power system. It is important to ensure their smooth integration in the power system to avoid simultaneous peaks during charging periods. However, due to their fast response and V2G mode, EVs serve as potential flexibility services providers [195–197]. As the minimum bid for providing AS is set by the TSO, an aggregator of EVs should be in charge of grouping EVs. In order to fully exploit the benefits of flexible charging and AS provision, the potential barriers, such as regulatory framework, BES degradation, installation of bi-directional charging facilities, have to be overcome [198]. The work in Ref. [199] tested and validated the feasibility of providing congestion management, local voltage support, and frequency-controlled normal operating reserve not considering vehicle-to-grid scheme at all with the very fast response time.

In order to decide on the profitability of investment in the aggregation of EVs or in BES, the model in Ref. [200] describes the investor's bidding in dynamic support services (flexible ramping products). Taking into account the communication infrastructure cost, BES depreciation cost, and the cost for additional hardware for bidirectional V2G service related to aggregation of EV and investment in storage, the results show that EV aggregation is a more profitable decision. A non-cooperative Stackelberg game with EV aggregator setting the price and EVs adjusting their charging/discharging behavior in order to provide frequency services is demonstrated in Ref. [201]. On the other hand, a cooperative V2G system maximizes its social welfare. The results show that EVs can smooth out the power fluctuations from the grid with higher social welfare in a cooperative game. When a provision of different services on the BES life cycle is explored, peak shaving is more degrading compared to frequency regulation due to the higher depth of discharging [202].

Providing AS to the power system can negatively impact the BES life cycle. To satisfy the energy need of EVs and to provide frequency regulation, the owner must be aware of a higher degradation rate. Although providing frequency regulation is the most profitable solution

due to contracted capacity and activation payment, the financial benefits of providing flexibility service are small without any incentives from the government or utility side [203]. If capacity lost in the BES is expressed as BES aging cost, flexible charging of EVs results in higher aging cost compared to the fixed charging. To overcome this issue and to encourage owners to participate in AS provision, a compensation scheme for BES utilization has been introduced to lower BES aging cost [204]. Different operation strategies in providing frequency-controlled normal operation reserves considering penalties for BES degradation, unavailability time, and congestion are investigated in Ref. [205]. The more sophisticated operation strategy, such as the preferred operating point mechanism in which the EV can provide the service at any time due to optimal control of EV's SOC, brings more benefits to the owner (lower penalty cost for BES degradation and unavailability period). Uncertainty related to market prices, required energy for EV trips, deployment signals [206], arrival/departure time, driving distance, and availability during the plug-in period [207] have a significant impact on the profit obtained from providing AS [206] and bidding capacity time [207]. Joint p2p energy trading and AS provision differ between aggressive, moderate, and conservative end user's profiles (the most aggressive profile allows the deepest depth of discharge) [208]. A more aggressive pattern results in more energy used for AS provision and p2p energy trading with higher savings.

The DSO is responsible to ensure the adequate quality of delivered electricity, to minimize distribution cost and improve power quality. Instead of changing the infrastructure business model in the system with high penetration of MV and LV connected RES, the DSO can use the p2p platform to solve their technical network constraints violations with minimum information revelation to other parties [209]. P2p energy trading will not just enhance the local energy exchange between consumers, but also enable p2p trading between final users on one side and DSO on the other side. P2p trading platform opens the door for flexibility service provision to the DSO through contracts to subscribed prosumers [210]. Moreover, the DSO can send locational marginal prices to the p2p market in order to avoid local congestion [211]. Authors in Ref. [212] propose a grid tariff offered to the prosumers that cause voltage or congestion problems. The tariff is implemented in the p2p market through a product differentiation approach. On the other hand, authors

in Ref. [192] fear that p2p trading mechanisms could result in low negotiated power between the DSO and flexibility service providers.

The balancing energy in RT should be traded based on marginal-bid pricing on the separate market from the balancing capacity market which will result in reduced balancing cost [213]. Several barriers for DA balancing markets are divided into three categories: regulatory, technical, and economic barriers [214]. Regulatory barriers should be removed to enable market entrance for all entities, even small consumers. It is also important to reduce the technical constraints of consumption sites. If the duration of delivery and notification time are low or if the offer is asymmetric, technical prequalification is eased. Market place should be well designed with low technical costs and low penalizations to ensure the profitable participation of small consumers. Economic preferences (life cycle cost, economies of scale, and net present value) can help in investor's and the government's decision-making process in microgrids [215]. Moreover, some consumers can decide to go off-grid because installing PV and BES serves as a cheaper option compared to the energy supplied from the network [216]. Different pricing can be proposed for consumers with installed distributed renewable energy sources in order to achieve fairness and efficiency: conventional tariff, flat-rate tariffs, ToU tariff, RT pricing, and demand charge tariff [217].

6.2. Coordination between system operators in ancillary services provision

In order to coordinate providing flexibility from the resources connected to the distribution grid, it is important to ensure adequate communication and information exchange between the DSO and the TSO to avoid the reservation and activation of counteracting service.

Several TSO-DSO coordination schemes are proposed in the literature and demonstrated in pilot projects (SmartNet [218–220], CoordiNet [221], TDX assist [222,223]). Coordination schemes are categorized in 5 groups, as shown in Table 5. A detailed description of each group and the differences between grouped coordination mechanisms are described below.

In TSO-DSO central-based coordination schemes, the TSO is the only buyer of AS provided from DERs. The role of the DSO is limited to product and system prequalification to ensure that DER can provide

Table 5
TSO-DSO coordination schemes.

Central based	Local based	Shared responsibilities	Common based	Integrated based
Centralized AS Market Model (SmartNet)	Local AS Market Model (SmartNet)	Shared Balancing Responsibility Market Model (SmartNet)	Common AS Market Model (SmartNet)	Integrated Flexibility Market Model (SmartNet)
Central market model (CoordiNet)	Local market model (CoordiNet)	Fragmented market model (CoordiNet)	Common market model (CoordiNet)	Integrated Market Model (CoordiNet)
Total TSO model [224]	Multi-level market model (CoordiNet)	System Balancing Cost Allocation based on the Cost-Causality Principle [225]	Hybrid model [226]	Distributed market models (CoordiNet)
Minimized or minimal DSO model [224]	Cascade model [227]	Market DSO model C1 and C2 [224]	Combined TSO and DSO congestion management with separated balancing [228]	Regional Intraday Plus market [227]
Full integration market model [229]	Market DSO model C1 (and C2) [224]	Total DSO model [224]	Combined balancing and congestion management for all system operators together [228]	Sequential Design, TSO-DSO Mechanism, and TSO-DSO-Retailer Mechanism [230]
Enhanced Bulk Balancing Authority Model variant A [226]	Total DSO model [224]	DSO procures the flexibility services and provides the forecasted load/generation by primary substation (TDX-ASSIST)	Single Flexibility Market Place [231]	
Enhanced Bulk Balancing Authority Model variant B [226]	Separated TSO and DSO congestion management [228]		New flexibility platform [227]	
Regional Reserve Market Plus [227]	Coordination mechanism between local and national market (TDX-ASSIST)		TSO and DSO procure flexibility services in a single flexibility market (TDX-ASSIST)	
Market DSO model C1 and C2 [224]				
Total DSO model [224]				
TSO procures the flexibility services and the DSO should validate their activation (TDX-ASSIST)				

specific service and that the activation of the required service does not harm distribution network constraints. However, some differences between schemes are relevant. Usually, the DSO observes the distribution grid, while in the Total TSO model and in the Full integration market model the TSO performs optimization in both transmission and distribution grid. In Minimized or minimal DSO model DSO dispatches DERs on the request from the TSO. In Enhanced Bulk Balancing Authority Model variant A the DSO provides to the TSO the status of the distribution grid (TSO is in charge of DER dispatching), while in variant B the DSO dispatches DERs based on the instruction from the TSO. In Regional Reserve Market Plus the DSO can use DERs to solve local congestion but has to inform the TSO about it.

Market DSO model C1 and C2 and Total DSO model are part of three groups due to their complexity. The DSO operates distribution grid and DERs on the distribution level, coordinates local aggregators for DERs dispatch on the TSO behalf or for participation in the global market.

In the local-based coordination mechanisms, the DSO has the priority in procuring AS from resources connected to DG. Bids not selected for local use are aggregated and forwarded to the global market operated by the TSO. However, in the cascade model, the bids not cleared at the local market for congestion management are not offered to the TSO. In Separated TSO and DSO congestion management, DSO Congestion Management is separated from TSO congestion management and balancing.

In TSO-DSO coordination with shared responsibilities, the roles and responsibilities of the TSO and the DSO are clearly defined and completely separated. The DSO is responsible for the control and balancing in the distribution network, while the TSO in the transmission network. Only DSO can use local DERs to solve voltage problems and congestion in the distribution grid, but at the same time keeps the energy exchange profile at TSO-DSO connection points as agreed with the TSO. In System Balancing Cost Allocation based on the Cost-Causality Principle, a final customer pays a portion of the system charge depending on their contribution to system imbalance.

Common-based coordination schemes represent the most sophisticated scheme in which total social welfare is maximized because TSO and DSO closely collaborate. ASs are procured in one common market from resources connected to the distribution and transmission network. The common market is operated jointly by the DSO and TSO. Both system operators have the same priority in procuring AS from DERs.

While usually the TSO is responsible for balancing, in the Hybrid model DSO and TSO share the balancing responsibility.

In integrated-based coordination schemes both regulated and deregulated market players can procure AS which yields to direct competition between all market participants. A third party operating the market is necessary to ensure neutrality. This type of market has high liquidity because flexibility resources are allocated based on the highest payment which incentivizes competition between demand-side resources. Moreover, the system operators can resell unneeded volumes of AS previously contracted in the market, but also buy the unneeded service from the market player selling it. In the Regional Intraday Plus market products for balancing and congestion management are integrated. Distributed market models are a bit different from other coordination schemes in group 5 in which peers are focused on their own welfare, and there is no guarantee for reaching the optimal social one. This kind of market requires restructuring of current regulation and market setup.

7. Models and discussion on different opportunities for flexible prosumers

In addition to a comprehensive review of the evolution of existing and upcoming opportunities for flexible prosumers the following Section explains and analyses easy-to-understand models and results for the options analyses in the review part of previous sections. These opportunities arise from different market changes, creating new and diverse pricing strategies and investment in different low carbon technologies, aggregation, and internal energy exchange between community members.

7.1. Prosumer's behavior under different pricing strategies

The prosumer might be willing to modify their consumption according to several types of incentives (shifting consumption during the periods of a lower price or during the periods of high PV production). Three different pricing mechanisms are used based on real-life existing models:

1. Flat tariff – only one (flat) price per kWh is used for the period of the entire year,

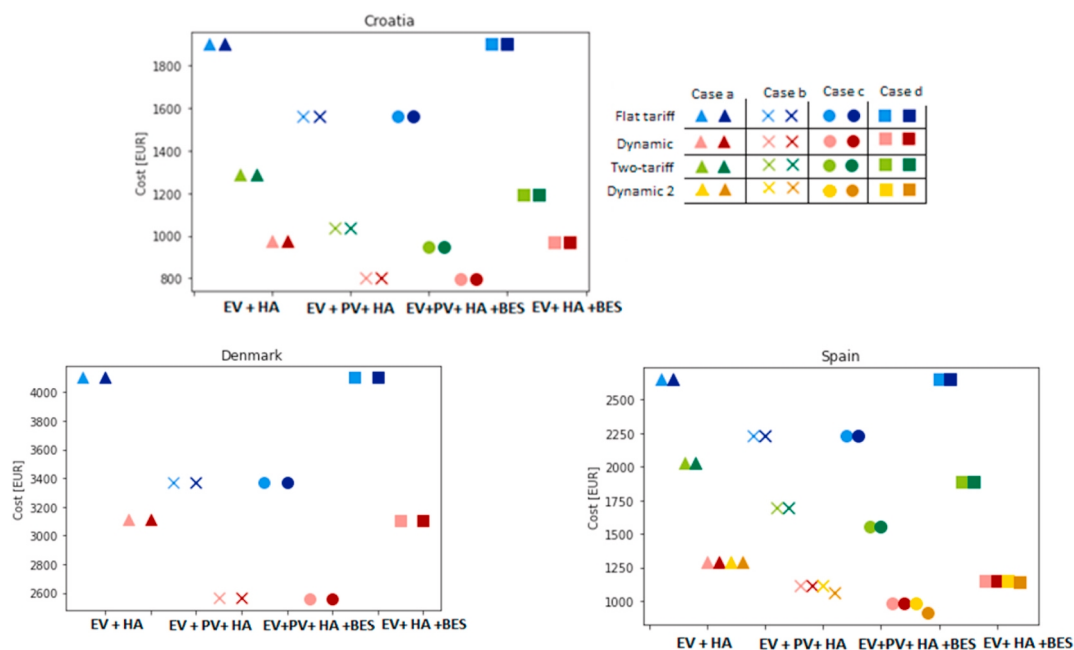

Fig. 6. Yearly electricity costs under different pricing schemes for different type of flexible consumer/prosumer in Croatia, Denmark, and Spain.

2. Two-tariff pricing – two different prices are used, peak price during the day, and off-peak price during the night,
3. Dynamic pricing – prices change dynamically according to the electricity market price.

The annual costs in euros are presented in Fig. 6 for 3 countries: Croatia, Denmark, and Spain. Dynamic RT retail electricity prices do not exist in Croatia. Prices considered in this simulation are taken from the Croatian Power Exchange (CROPEX). Croatian electricity market is the least developed of the three mentioned countries and, due to low market liquidity, the market prices are very high. We wanted to investigate is it beneficial to stay under existing pricing contract (flat or two-tariff pricing) with current market conditions. As a European country with almost the highest electricity prices, Denmark is chosen to demonstrate the impact of additional charges, system tariff, balancing fee, extremely high VAT and other taxes on the final user's cost. The Spanish case is chosen due to obligatory capacity payment and to demonstrate the reduction in electricity cost if the final user has the same buying and selling price.

The results represent annual electricity bills which include electricity cost, taxes, RES subsidies, network fees and additional charges. To quantify the cost savings between flat tariff, two-tariff pricing, and dynamic pricing, we ran an algorithm in which a final customer has a basic consumption profile and a flexible start-up time of household appliances (HA): washing machine (cycle length: 3 h, total energy consumption: 1.35 kWh), tumble dryer (cycle length: 2 h, total energy consumption: 1 kWh) and dishwasher (cycle length: 1 h, total energy consumption: 1 kWh). EV has a charging power of 3.7 kW and a BES capacity of 30 kWh with the desired SOC of 25.9 kWh at the end of the charging period. The consumer has installed 3 kW of PV. The household battery capacity is 4 kWh. A detailed mathematical description and explanation of the model can be found in Ref. [232]. Two types of prosumers are observed: the first ones are self-sufficient who manage their consumption so that it matches the production from PV, and the second-ones are price-driven and have the possibility of selling excess PV production (the optimization algorithm minimizes the cost of buying energy deficit and maximizing the profit from selling excess PV production).

The final customer is modelled as follows:

- a. Prosumer has EV and flexible start-up time of household appliances (EV + HA),
- b. Prosumer has EV, PV, and flexible start-up time of household appliances (EV + PV + HA),
- c. Prosumer has EV, PV, BES, and flexible start-up time of household appliances (EV + PV + HA + BES),
- d. Prosumer has EV, BES, and flexible start-up time of household appliances (EV + HA + BES),

Electricity prices are described for each country:

- Croatia:
 - flat tariff: 0.875 HRK/kWh or 0.117 EUR/kWh [233],
 - two-tariff pricing: lower prices from 22 h to 8 h 0.515 HRK/kWh or 0.0687 EUR/kWh and higher 0.945 HRK/kWh or 0.126 EUR/kWh [233,234].
 - selling price for excess PV production is regulated by Ref. [235], and for the purpose of this algorithm is set at 80% of buying price, without network fees and RES subsidies [236],
 - electricity suppliers in Croatia do not offer dynamic electricity prices, while for the purpose of the paper DA prices from Croatian Power Exchange are considered [237].
 - each prosumer needs to pay 300 HRK on annual base (40 EUR) for distribution fee and billing metering point
 - tax in Croatia for electricity is 13%.
- Denmark:

- flat tariff: 0.46 DKK/kWh or 0.0613 EUR/kWh [238] plus additional charges,
- selling price is lower than buying price, for the purpose of the paper is set at 0.25 DKK/kWh [239] minus balancing fee 0.123 ORE/kWh [240],
- no two-tariff pricing,
- dynamic pricing is equal to spot market price from Noordpol [241] plus 0.12 DKK/kWh (according to electricity provider Modstorm [242]) plus additional charges,
- additional charges: transmission network fee: 4.9 ORE/kWh, system tariff 6.1 ORE/kWh, balancing fee 0.229 ORE/kWh [240], distribution network fee 16.9 ORE/kWh, public service obligation 15.5 ORE/kWh, electricity tax 63.5 ORE/kWh, other charges 17.5 ORE/kWh plus 25% VAT on the final price [243].
- 924 DKK on annual base for supply contract charge and grid access charge increased for 25% VAT [243].
- Spain:
 - flat tariff: 0.127003 €/kWh [244], 0.04403 EUR/kWh distribution and transmission network fee [245].
 - two-tariff pricing: higher tariff 0.158614 EUR/kWh and lower tariff 0.079420 EUR/kWh [246], distribution and transmission network fee during higher tariff 0.06201 EUR/kWh a during lower tariff 0.00222 EUR/kWh [245].
 - dynamic price: efficiency 2 periods (DHA) tariff of active energy invoicing price [245] which includes distribution and transmission network fee
 - selling price: self-consumption surplus energy price for the simplified compensation mechanism (PVPC) [247],
 - capacity payment 3.429702 EUR/kW/month [246] (7 kW),
 - dynamic pricing 2: hypothetically the same dynamic buying and selling price,
 - 5.11% taxes,
 - measurement and control equipment rental 9.71 EUR/year,
 - 21% VAT.

Different marks represent different case studies as described above (triangle represents case a, consumer with EV and HA, cross case b, circle case c and rectangle case d). Moreover, different colors represent pricing mechanisms (blue is a flat tariff, green two-tariff pricing, red dynamic pricing, and yellow dynamic pricing in Spain if prosumer is exposed to the same buying and selling price). The lighter color is a self-sufficient prosumer, while a dark color is a price-driven prosumer.

The first type of prosumer strives to be self-sufficient, meaning its goal is to maximize the consumption of its locally produced electricity.

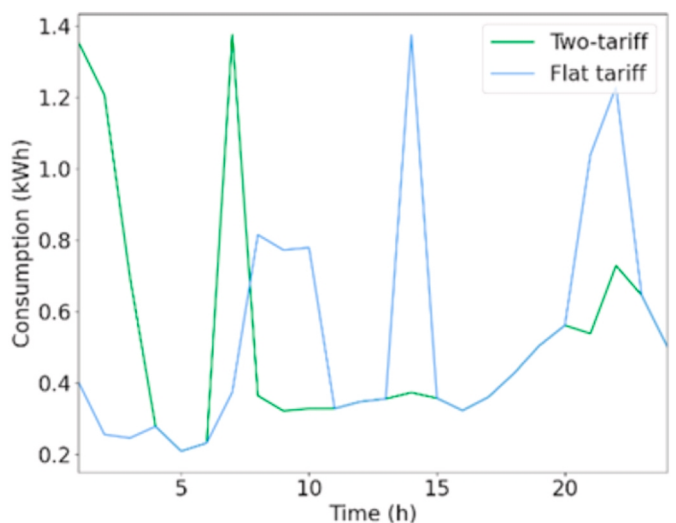

Fig. 7. Energy consumption under flat tariff and two-tariff pricing.

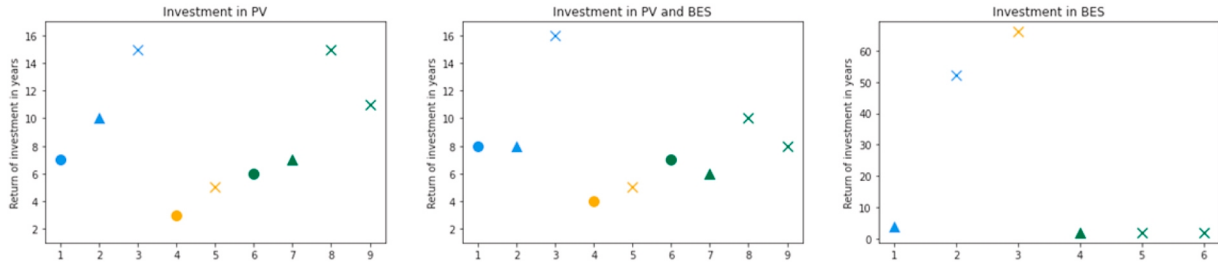

Fig. 8. Return of investment.

The second type can sell excess energy to the supplier (or to the market) and optimizes its consumption driven by prices from the supplier and strives to minimize its electricity cost. The cases might not be fully realistic, however, they are created to understand the impact of price signals on prosumers behavior.

Flat-tariff pricing is the least profitable option in each country, and it does not encourage the flexible behavior of prosumers. Investment in BES does not bring any savings under flat-tariff pricing. When looking closer at the behavior profiles of the prosumers, driven by different electricity prices, it can be noticed that they look the same in self-sufficient and price-driven cases. This implies that neither of the existing electricity price signals incentivizes prosumers to sell excess PV production as this does not result in cost savings or additional profits. In short, regardless of the price tariffs selected, the prosumers will have the same behavior towards the system and that is to maximize consumption of the locally produced electricity. They will have no additional benefits if they sell excess PV production. On the other hand, if prosumers are hypothetically exposed to the same dynamic selling and buying prices, additional cost-reduction in electricity bill will be achieved (dynamic pricing 2 in Spain). The highest savings were achieved (almost 8%) when prosumer owns all proposed low-carbon technologies (BES, PV, flexible household appliances and EV), compared to the less flexible situations 4.7% (without BES) and 0.8% (without PV).

Dynamic prices in Croatia are taken directly from the Croatian power exchange. Albeit the final prosumer under this dynamic pricing bears lower electricity cost compared to two-tariff pricing, it needs to be highlighted that the final prosumer will never have access directly to market prices (in Denmark the final prosumer has the access to the market price increased for 12 ORE/kWh [242]) which means it is important to create adequate dynamic pricing in future to attract more prosumers, as it is the situation in Spain where dynamic pricing brings 50% of reduction in electricity bill compared to two-tariff pricing.

To quantify the cost savings between flat tariff in Croatia [233], we ran an algorithm in which a final customer has a basic consumption profile and a flexible start-up time of washing machine (cycle length: 3 h, total energy consumption: 1.35 kWh), tumble dryer (cycle length: 2 h, total energy consumption: 1 kWh) and dishwasher (cycle length: 1 h, total energy consumption: 1 kWh). The change in consumers' behavior for one day is shown in Fig. 7:

It can be noticed that under two-tariff pricing, household appliances were started during the periods of lower prices resulting in lower electricity costs. The cost of the final customer is reduced by 10% when switching from the flat tariff to two-tariff pricing (with the same blue consumption curve), while turning on the appliances during the night (green consumption curve) can save almost 23% (daily cost reduction is about 20 cents before network fees, RES incentives, taxes, and additional charges).

7.2. Profitability of investment in low-carbon technologies

The market liberalization opened the doors for competition between electricity suppliers who started to offer lower electricity prices with the lower period of contract duration in order to gather a higher number of

consumers. In order to reduce the harmful effect of greenhouse gas emissions on climate changes, RESs have become an appropriate alternative to gas or coal power plants. The variable nature of RESs and their intermittent production require the increased flexibility to keep the system operation secure and efficient. Traditionally this flexibility was provided by conventional power plants connected to the transmission network. In recent years, the role of the final customers has completely changed. They have become the main drivers in the clean energy transition. Instead of being just passive consumers, they are seen as the main flexibility sources in the low-carbon environment. With the price decrease of household PV, BES and EVs, these new technologies will become affordable to the broader population. The cost of PV installations back in 2010 was more than 4600\$/kW, while the predicted price fall is to around 600 \$/kW by 2030, and 400 \$/kW by 2050 [248]. International Renewable Energy Agency predicts that BES price will fall around 60% for all BES technologies by 2030 compared to the prices in 2016 [249].

We wanted to investigate in the profitability of investment in low-carbon technologies. The model includes home EV charging (3.7 kW charging power and 30 kWh BES capacity), flexible start-up time of household appliances (HA) as described above, BES 4 kWh with the approximative cost of 100\$/kWh (340 euros in total) and household solar panel (PV) 3 kW with 1000 \$/kW (2540 euros in total). Fig. 8 shows the investment return in years (blue color represents Croatia, yellow color Denmark, and green color Spain, while circles stand for flat tariff, triangles for two-tariff pricing and x symbols for dynamic pricing):

It is very interesting to notice that the shortest period of investment return is for the flat tariff in all countries for PV and both technologies (except the investment in BES which does not reduce the cost under flat tariff, i.e., circles are omitted from the last graph). The highest period of investment return in PV is in Spain and Croatia under dynamic pricing with different buying and selling prices, 15 and 16 years. The lowest period of investment return is in Denmark for PV and both technologies, while the investment in BES is not profitable at all in Denmark under dynamic pricing mechanism. On the other hand, investment in BES pays off for 2 years in Spain under dynamic pricing and two-tariff pricing.

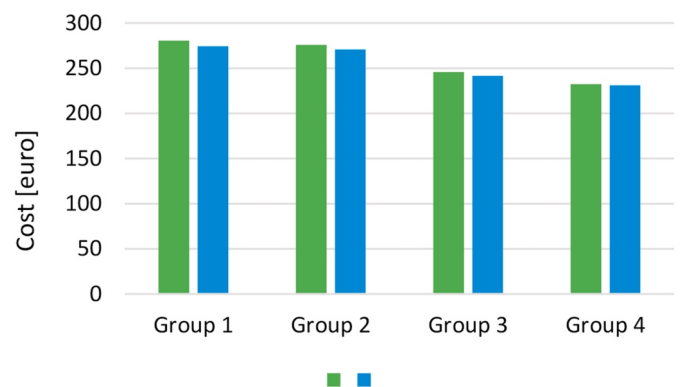

Fig. 9. The cost comparison between individual and aggregated consumers.

7.3. Advantages of aggregation and internal energy exchange

Aggregation can be beneficial to the system if it increases the economic efficiency of the system as a whole. On the other hand, it can only be focused on increasing the welfare of a single entity or a specific group. The final customer as a small entity might not be able to hedge against the price risks, unlike bigger entities, such as aggregators, who act as intermediaries between the final customers and the market. Aggregators have different hedging opportunities available, such as different types of service provision, diverse types of final customers in their portfolio, multiple tools for data predictions and information gathering, etc. Aggregators create adequate price signals for final customers in order to change their electricity consumption behavior. The latest definition of prosumer as described in Ref. [250] says that prosumers are end-users who generate and consume their own energy, provided that self-generation does not constitute their primary commercial activity, and that they are connected to the grid, and do not engage in net-metering schemes. To expand our simulations, we created a group of aggregated prosumers to show lower electricity costs when participating as one entity on the market. The results in Fig. 9 compare the daily cost between the group of 100 consumers in which each consumer has signed an individual contract with the supplier trying to minimize electricity bill (1) and aggregated consumers participating on the market as one entity (2). Final customers are not balancing responsible. They usually sign an individual contract with the supplier who belongs to a balancing group lead by a balancing responsible party who set a fixed balancing price for each consumed kWh of energy [240]. In order to achieve a better market position, but also provide additional flexibility to the power system, aggregated final consumers can join the energy community in which they could be offered flexibility incentives in order to follow their predefined DA schedule and reduce the system balancing cost. This directly helps the system operator because the flexibility incentives are set to penalize the deviation from the DA schedule. In order to achieve lower electricity cost, final consumers flexible shift their consumption to mitigate these deviations.

The buying price for final prosumer d is composed of dynamic price

offered by the supplier for buying $\lambda_t^{DA B}$ and selling energy $\lambda_t^{DA S}$, while for each consumed kWh prosumer is obliged to pay balancing buying fee $\lambda^{BAL B}$ and network charges $\lambda^{NET B}$ and for each injected kWh a selling balancing fee $\lambda^{BAL S}$.

$$\min \sum_{t \in T} \Delta t \left[(\lambda_t^{DA B} + \lambda^{BAL B} + \lambda^{NET B}) \cdot P_{d,t}^B - (\lambda_t^{DA S} - \lambda^{BAL S}) \cdot P_{d,t}^S \right] \forall d \quad (1)$$

Instead of paying balancing fee for bought $\lambda^{BAL B}$ and sold $\lambda^{BAL S}$ energy [251], community is exposed to flexibility incentives λ_t^{UP} and λ_t^{DOWN} which encourage members to follow the predefined DA buying schedule $P_t^{DA B}$ and selling schedule $P_t^{DA S}$. These flexibility incentives reduce the deviation from predefined DA schedule $P_{s,t}^{UP}$ and $P_{s,t}^{DOWN}$.

$$\min \sum_{t \in T} \Delta t \left[\lambda_t^{DA B} \cdot P_t^{DA B} - \lambda_t^{DA S} \cdot P_t^{DA S} + \sum_{s \in S} \pi_s \left(\lambda_t^{UP} \cdot P_{s,t}^{UP} - \lambda_t^{DOWN} \cdot P_{s,t}^{DOWN} \right) + \lambda^{NET B} \cdot P_{s,t}^+ \right] \quad (2)$$

The results are demonstrated for different groups of consumers:

- Group 1: all consumers have PV, 50% of them have flexible start of uninterruptible appliances and none has BES,
- Group 2: 50% of consumers have PV, BES, and flexible start of uninterruptible appliances,
- Group 3: all consumers have PV, 50% of them have BES and flexible start of uninterruptible appliances,
- Group 4: all consumers are equipped with PV, BES and flexible start of uninterruptible appliances.

The highest cost savings are achieved for the first group (approximately 2.2% cost reduction in aggregated case). It is interesting to notice that the more diverse consumers have fewer flexibility options, aggregation is a more preferable option.

The comparison between the final customer's cost in the individual contracting and energy community is shown in Fig. 10 for each group of prosumers defined above:

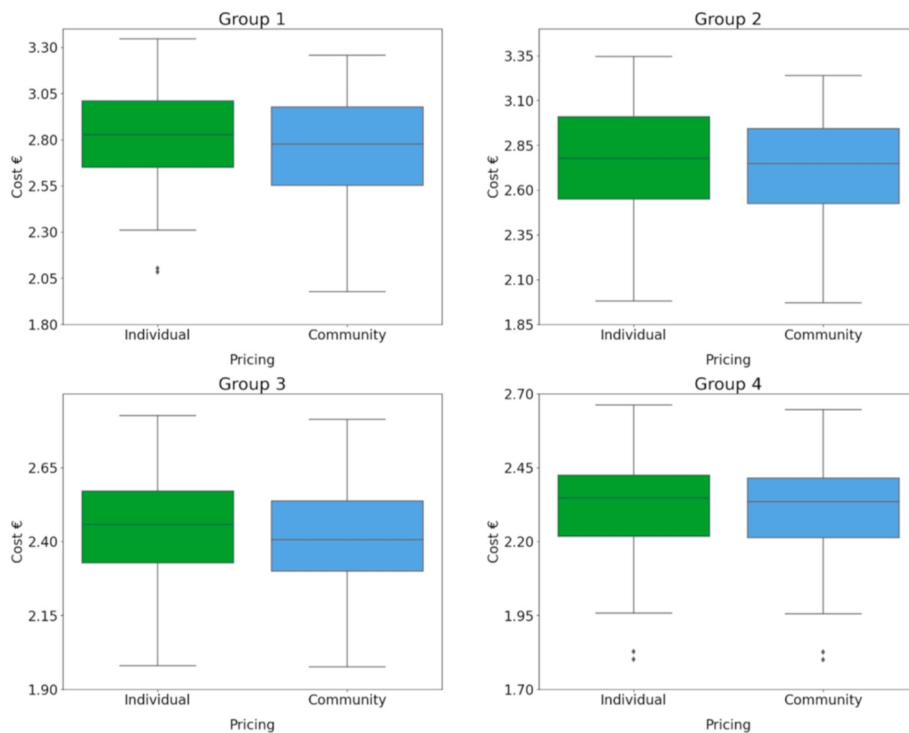

Fig. 10. Cost comparison between individual prosumers and community trading.

It can be seen that prosumers engaged in the energy community (who are encouraged to shift their demand in order to adjust their consumption to predefined DA schedule and avoid being penalized) bear lower electricity cost compared to the individual contracting with the supplier. Moreover, prosumers in the energy community who have more flexibility options (Group 4 compared to Group 1) have lower electricity cost. The result of individual community member highly depends on the composition of the entire community. Community members can reduce their electricity costs if some members have excess PV production. Instead of selling the surplus to the grid at a lower rate compared to the buying price, PV excess can be shared among members for the price beneficial for both buyers and sellers. The most profitable solution is the load shifting of flexible members to the periods with excess PV production. It is not beneficial if every community member owns PV because the community will need to sell the excess PV production at a lower rate instead of exchange it internally.

8. Conclusion

The clean energy policy faces big challenges in the transition towards carbon-neutral power systems. To reduce greenhouse gas emissions, an increasing number of EVs and RES are being integrated in the system. Their intermittent nature of consumption and production requires additional flexibility in the system to ensure stable and secure system operation with efficient energy supply to all users. Along with traditional flexibility providers, such as conventional power plants, the focus nowadays has been put on providing flexibility from a final customer.

The paper gives an extensive review of the evolution of the flexible behavior of a final customer. We firstly describe demand shifting through different pricing offers from a supplier (ToU, CPP, peak-time rebates, SWPT, RT pricing). Detail description of methodology, case study, benefits and quantitative results are provided for each type of pricing, while the papers are grouped based on the optimization type (bilevel programming, heuristic, game-theory, direct optimization, commercial software). Numerical example used in this paper tested the behavior and cost reduction of final user regarding the investment in different type of low-carbon technology under flat, two-tariff and dynamic prices. Switching from flat tariff in Croatia to two-tariff and dynamic pricing can reduce electricity cost up to 32% and 52%, respectively. However, the Croatian dynamic prices are extracted directly from the wholesale market and no additional price increase is applied for the purpose of the simulation. Albeit in the reality the retailer will need to set a profit margin in order to achieve a profitable business case (retailer's price have to be higher than wholesale market prices), according to the results, dynamic prices will be the most profitable option for the final user. It is interesting to notice that consumer in Denmark can save only 24% when switching from flat tariff to dynamic pricing due to electricity tax, additional charges, and extremely high VAT on the final price. The fastest return of investment period has Spain where BES pays off after 2 years under dynamic pricing and two-tariff pricing.

To achieve lower cost and share energy locally, final prosumers could be aggregated in an energy community or microgrid and jointly participate in the market. We provide a detailed description of diverse forms of aggregation and participation in the DA, intra-day, balancing and RT market. Final customers can form an internal market for p2p energy trading and trade directly between peers. Multiple pricing mechanisms are elaborated (direct optimization, game theory models, and coalition games). Community members can reduce their electricity costs if the energy is shared locally. Instead of selling the surplus to the grid at a lower rate compared to the buying price, PV excess can be shared among members for the price beneficial for both buyers and sellers.

The final step in consumer's flexible behavior is providing AS through incentive-based DR or participation in the AS market to help system operators to ensure secure and reliable distribution and

transmission network operation. Several TSO-DSO coordination mechanisms in providing AS are described and the focus has been put on the role of the final customer.

Declaration of competing interest

The authors declare that they have no known competing financial interests or personal relationships that could have appeared to influence the work reported in this paper.

Acknowledgement

This work has been supported in part by the European Structural and Investment Funds under project KK.01.2.1.02.0063 SUPER (System for optimization of energy consumption in households) as well as by the Croatian Science Foundation and European Union through the European Social Fund under project Flexibility of Converter-based Microgrids – FLEXIBASE (PZS-2019-02-7747).

References

- [1] 2030 climate & energy framework | Climate Action n.d. https://ec.europa.eu/clima/policies/strategies/2030_en (accessed September 28, 2020).
- [2] DIRECTIVE (EU) /944 OF THE EUROPEAN PARLIAMENT AND OF THE COUNCIL of 5 June 2019 on common rules for the internal market for electricity and amending Directive 2012/27/EU n.d. <https://eur-lex.europa.eu/legal-content/EN/TXT/PDF/?uri=CELEX:32019L0944&from=EN>. [Accessed 26 May 2020].
- [3] COMMISSION REGULATION (EU). Establishing a guideline on electricity transmission system operation. 2019. 2017/1485 of 2 August 2017.
- [4] Andrew J. Pimma, Tim T. Cockerilla PGT. Time-of-use and time-of-export tariffs for home batteries Effects on low.pdf n.d. <https://doi.org/https://doi.org/10.1016/j.est.2018.06.008>.
- [5] Meyabadi AF, Deihimi MH. A review of demand-side management: reconsidering theoretical framework. *Renew Sustain Energy Rev* 2017;80:367–79. <https://doi.org/10.1016/j.rser.2017.05.207>.
- [6] Haider HT, See OH, Elmenreich W. A review of residential DR of smart grid. *Renew Sustain Energy Rev* 2016;59:166–78. <https://doi.org/10.1016/j.rser.2016.01.016>.
- [7] Sharifi R, Fathi SH, Vahidinasab V. A review on Demand-side tools in electricity market. *Renew Sustain Energy Rev* 2017;72:565–72. <https://doi.org/10.1016/j.rser.2017.01.020>.
- [8] Yan X, Ozturk Y, Hu Z, Song Y. A review on price-driven residential DR. *Renew Sustain Energy Rev* 2018;96:411–9. <https://doi.org/10.1016/j.rser.2018.08.003>.
- [9] Huang W, Zhang N, Kang C, Li M, Huo M. From DR to integrated DR: review and prospect of research and application. *Prot Control Mod Power Syst* 2019;4. <https://doi.org/10.1186/s41601-019-0126-4>.
- [10] Curtin J, McInerney C, Ó Gallachóir B. Financial incentives to mobilise local citizens as investors in low-carbon technologies: a systematic literature review. *Renew Sustain Energy Rev* 2017;75:534–47. <https://doi.org/10.1016/j.rser.2016.11.020>.
- [11] Sousa T, Soares T, Pinson P, Moret F, Baroche T, Sorin E. Peer-to-peer and community-based markets: a comprehensive review. *Renew Sustain Energy Rev* 2019;104:367–78. <https://doi.org/10.1016/j.rser.2019.01.036>.
- [12] Carreiro AM, Jorge HM, Antunes CH. Energy management systems aggregators: a literature survey. *Renew Sustain Energy Rev* 2017;73:1160–72. <https://doi.org/10.1016/j.rser.2017.01.179>.
- [13] Gough M, Santos SF, Javadi M, Castro R, Catalão JPS. Prosumer flexibility: a comprehensive state-of-the-art review and scientometric analysis. *Energies* 2020; 13:1–33. <https://doi.org/10.3390/en13112710>.
- [14] da Silva PP, Cerqueira PA. Assessing the determinants of household electricity prices in the EU: a system-GMM panel data approach. *Renew Sustain Energy Rev* 2017;73:1131–7. <https://doi.org/10.1016/j.rser.2017.02.016>.
- [15] Silva HB da, Santiago LP. On the trade-off between real-time pricing and the social acceptability costs of DR. *Renew Sustain Energy Rev* 2018;81:1513–21. <https://doi.org/10.1016/j.rser.2017.05.219>.
- [16] Jordehi AR. Optimisation of DR in electric power systems, a review. *Renew Sustain Energy Rev* 2019;103:308–19. <https://doi.org/10.1016/j.rser.2018.12.054>.
- [17] Moira L. Nicolson, Michael J. Fell GMH. Consumer demand for time of use electricity tariffs.pdf n.d. <https://doi.org/https://doi.org/10.1016/j.rser.2018.08.040>.
- [18] Musiliu O. Osenia MGP. The prospects for smart energy prices.pdf n.d. <https://doi.org/https://doi.org/10.1016/j.rser.2016.11.214>.
- [19] E.A.M. Klaassen a, b,†, C.B.A. Kobus b, c, J. Frunt a, d JGS. Responsiveness of residential electricity demand to dynamic tariffs.pdf n.d. <https://doi.org/https://doi.org/10.1016/j.apenergy.2016.09.051>.
- [20] EED. Directive. 2012/27/EU of the European parliament and of the council of 25 October 2012 on energy efficiency. 2012. p. 1–56.
- [21] IRENA. Time-of-Use Tariffs 2019;1–18.

- [22] Li C, Tang S, Cao Y, Xu Y, Li Y, Li J, et al. A new stepwise power tariff model and its application for residential consumers in regulated electricity markets. *IEEE Trans Power Syst* 2013;28:300–8. <https://doi.org/10.1109/TPWRS.2012.2201264>.
- [23] Nan S, Zhou M, Li G. Optimal residential community DR scheduling in smart grid. *Appl Energy* 2018;210:1280–9. <https://doi.org/10.1016/j.apenergy.2017.06.066>.
- [24] Elkazaz M, Sumner M, Naghiyev E, Pholboon S, Davies R, Thomas D. A hierarchical two-stage energy management for a home microgrid using model predictive and real-time controllers. *Appl Energy* 2020;269:115118. <https://doi.org/10.1016/j.apenergy.2020.115118>.
- [25] Pallonetto F, De Rosa M, Milano F, Finn DP. DR algorithms for smart-grid ready residential buildings using machine learning models. *Appl Energy* 2019;239:1265–82. <https://doi.org/10.1016/j.apenergy.2019.02.020>.
- [26] Li Y, Gao W, Ruan Y, Ushifusa Y. DR of customers in Kitakyushu smart community project to critical peak pricing of electricity. *Energy Build* 2018;168:251–60. <https://doi.org/10.1016/j.enbuild.2018.03.029>.
- [27] Kato T, Tokuhara A, Ushifusa Y, Sakurai A, Aramaki K, Maruyama F. Consumer responses to critical peak pricing: impacts of maximum electricity-saving behavior. *Electr J* 2016;29:12–9. <https://doi.org/10.1016/j.tej.2016.02.002>.
- [28] Eldali F, Hardy T, Corbin C, Pinney D, Javid M. Cost-benefit analysis of DR programs incorporated in open modeling framework. *IEEE Power Energy Soc Gen Meet* 2016;2016-Novem. <https://doi.org/10.1109/PESGM.2016.7741264>.
- [29] Muqet HAU, Ahmad A. Optimal scheduling for campus prosumer microgrid considering price based DR. *IEEE Access* 2020;8:71378–94. <https://doi.org/10.1109/ACCESS.2020.2987915>.
- [30] Zhou L, Zhang Y, Lin X, Li C, Cai Z, Yang P. Optimal sizing of PV and bess for a smart household considering different price mechanisms. *IEEE Access* 2018;6:41050–9. <https://doi.org/10.1109/ACCESS.2018.2845900>.
- [31] Zhou B, Yang R, Li C, Cao Y, Wang Q, Liu J. Multiobjective model of time-of-use and stepwise power tariff for residential consumers in regulated power markets. *IEEE Syst J* 2018;12:2676–87. <https://doi.org/10.1109/JSYST.2017.2718046>.
- [32] Talwariya A, Singh P, Kolhe M. A stepwise power tariff model with game theory based on Monte-Carlo simulation and its applications for household, agricultural, commercial and industrial consumers. *Int J Electr Power Energy Syst* 2019;111:14–24. <https://doi.org/10.1016/j.ijepes.2019.03.058>.
- [33] Zhang Y, Augenbroe G. Optimal demand charge reduction for commercial buildings through a combination of efficiency and flexibility measures. *Appl Energy* 2018;221:180–94. <https://doi.org/10.1016/j.apenergy.2018.03.150>.
- [34] Aslam S, Iqbal Z, Javaid N, Khan ZA, Aurangzeb K, Haider SI. Towards efficient energy management of smart buildings exploiting heuristic optimization with real time and critical peak pricing schemes. *Energies* 2017;10:1–25. <https://doi.org/10.3390/en10122065>.
- [35] Javaid N, Ahmed A, Iqbal S, Ashraf M. Day ahead real time pricing and critical peak pricing based power scheduling for smart homes with different duty cycles. *Energies* 2018;11. <https://doi.org/10.3390/en11061464>.
- [36] Naz M, Iqbal Z, Javaid N, Khan ZA, Abdul W, Almogren A, et al. Efficient power scheduling in smart homes using hybrid grey Wolf differential evolution optimization technique with real time and critical peak pricing schemes. *Energies* 2018;11:1–25. <https://doi.org/10.3390/en11020384>.
- [37] Zhou L, Zhang Y, Li K, Xie X. Optimal sizing of PV system and BESS for smart household under stepwise power tariff. *Int conf power syst technol POWERCON 2018 - proc 2019:1314–9*. 2018. <https://doi.org/10.1109/POWERCON.2018.8602146>.
- [38] Golmohamadi H, Keypour R, Bak-Jensen B, Radhakrishna Pillai J. Optimization of household energy consumption towards day-ahead retail electricity price in home energy management systems. *Sustain Cities Soc* 2019;47:101468. <https://doi.org/10.1016/j.scs.2019.101468>.
- [39] Guo P, Lam JCK, Li VOK. Drivers of domestic electricity users' price responsiveness: a novel machine learning approach. *Appl Energy* 2019;235:900–13. <https://doi.org/10.1016/j.apenergy.2018.11.014>.
- [40] Vuelvas J, Ruiz FDR. Understanding the rational behavior of consumers in a peak time rebate program. In: 2015 IEEE 2nd colomb conf autom control CCAC 2015 - conf pro, vols. 1–6. c; 2015. <https://doi.org/10.1109/CCAC.2015.7345196>.
- [41] Vuelvas J, Ruiz F. Rational consumer decisions in a peak time rebate program. *Elec Power Syst Res* 2017;143:533–43. <https://doi.org/10.1016/j.epr.2016.11.001>.
- [42] Liu Y, Xiao L, Yao G, Bu S. Pricing-based DR for a smart home with various types of household appliances considering customer satisfaction. *IEEE Access* 2019;7:86463–72. <https://doi.org/10.1109/ACCESS.2019.2924110>.
- [43] Zhou K, Wei S, Yang S. Time-of-use pricing model based on power supply chain for user-side microgrid. *Appl Energy* 2019;248:35–43. <https://doi.org/10.1016/j.apenergy.2019.04.076>.
- [44] Heleno M, Sehloff D, Coelho A, Valenzuela A. Probabilistic impact of electricity tariffs on distribution grids considering adoption of solar and storage technologies. *Appl Energy* 2020;279:115826. <https://doi.org/10.1016/j.apenergy.2020.115826>.
- [45] Koskela J, Rautiainen A, Järventausta P. Using electrical energy storage in residential buildings – sizing of battery and photovoltaic panels based on electricity cost optimization. *Appl Energy* 2019;239:1175–89. <https://doi.org/10.1016/j.apenergy.2019.02.021>.
- [46] Matar W. A household's power load response to a change in the electricity pricing scheme: an expanded microeconomic-physical approach. *Electr J* 2019;32:106644. <https://doi.org/10.1016/j.tej.2019.106644>.
- [47] Barbour E, González MC. Projecting battery adoption in the prosumer era. *Appl Energy* 2018;215:356–70. <https://doi.org/10.1016/j.apenergy.2018.01.056>.
- [48] Wang Y, Lin H, Liu Y, Sun Q, Wennersten R. Management of household electricity consumption under price-based DR scheme. *J Clean Prod* 2018;204:926–38. <https://doi.org/10.1016/j.jclepro.2018.09.019>.
- [49] Mohajeryami S, Schwarz P, Baboli PT. Including the behavioral aspects of customers in DR model: real time pricing versus peak time rebate. *North Am Power Symp NAPS*; 2015. <https://doi.org/10.1109/NAPS.2015.7335116>. 2015 2015.
- [50] Park SC, Jin YG, Song HY, Yoon YT. Designing a critical peak pricing scheme for the profit maximization objective considering price responsiveness of customers. *Energy* 2015;83:521–31. <https://doi.org/10.1016/j.energy.2015.02.057>.
- [51] HEP ODS - Tarifni modeli n.d. <https://www.hep.hr/ods/korisnici/kucanstvo/tarifni-modeli/34#> (accessed March 16, 2021).
- [52] Dettli R, Philippen D, Reinhardt K, Schäffler H, Heinemann C. *Smart Metering für die Schweiz – Potenziale, Erfolgsfaktoren und Massnahmen für die Steigerung der Energieeffizienz*, vol. 14; 2009.
- [53] Bertoldi P, Zancanella P, Boza-Kiss B. DR status in EU member states. 2016. <https://doi.org/10.2790/962868>.
- [54] Shah ZA, Sindi HF, Ul-Haq A, Ali MA. Fuzzy logic-based direct load control scheme for air conditioning load to reduce energy consumption. *IEEE Access* 2020;8:117413–27. <https://doi.org/10.1109/ACCESS.2020.3005054>.
- [55] Nunna KHSVS, Doolla S. Responsive end-user-based demand side management in multimicrogrid environment. *IEEE Trans Ind Informatics* 2014;10:1262–72. <https://doi.org/10.1109/TII.2014.2307761>.
- [56] Shad M, Momeni A, Errouissi R, Diduch CP, Kaye ME, Chang Liuchen. Identification and estimation for electric water heaters in direct load control programs. *IEEE Trans Smart Grid* 2017;8:947–55. <https://doi.org/10.1109/TSG.2015.2492950>.
- [57] Kim YJ, Wang J. Power hardware-in-the-loop simulation study on frequency regulation through direct load control of thermal and electrical energy storage resources. *IEEE Trans Smart Grid* 2018;9:2786–96. <https://doi.org/10.1109/TSG.2016.2620176>.
- [58] Zheng W, Wu W, Zhang B, Lin C. Distributed optimal residential DR considering operational constraints of unbalanced distribution networks. *IET Gener, Transm Distrib* 2018;12:1970–9. <https://doi.org/10.1049/iet-gtd.2017.1366>.
- [59] Simão HP, Jeong HB, Defourny B, Powell WB, Boulanger A, Gagneja A, et al. A robust solution to the load curtailment problem. *IEEE Trans Smart Grid* 2013;4:2209–19. <https://doi.org/10.1109/TSG.2013.2276754>.
- [60] Xing H, Cheng H, Zhang L. DR and wind farm integrated economic dispatch in power system. *IEEE Reg 10 Annu Int Conf Proceedings/TENCON 2016*. <https://doi.org/10.1109/TENCON.2015.7372867>. 2016-Janua:37–41.
- [61] Sousa JCS, Saavedra OR, Lima SL. Decision making in emergency operation for power transformers with regard to risks and interruptible load contracts. *IEEE Trans Power Deliv* 2018;33:1556–64. <https://doi.org/10.1109/TPWRD.2017.2764466>.
- [62] Yang L, He M, Vittal V, Zhang J. Stochastic optimization-based economic dispatch and interruptible load management with increased wind penetration. *IEEE Trans Smart Grid* 2016;7:730–9. <https://doi.org/10.1109/TSG.2015.2444813>.
- [63] Chen S, Chen Q, Xu Y. Strategic bidding and compensation mechanism for a load aggregator with direct thermostat control capabilities. *IEEE Trans Smart Grid* 2018;9:2327–36. <https://doi.org/10.1109/TSG.2016.2611611>.
- [64] Sadeghian O, Shotorbani AM, Mohammadi-Ivatloo B. Generation maintenance scheduling in virtual power plants. *IET Gener, Transm Distrib* 2019;13:2584–96. <https://doi.org/10.1049/iet-gtd.2018.6751>.
- [65] Zhu L, Zhou X, Zhang XP, Yan Z, Guo S, Tang L. Integrated resources planning in microgrids considering interruptible loads and shiftable loads. *J Mod Power Syst Clean Energy* 2018;6:802–15. <https://doi.org/10.1007/s40565-017-0357-1>.
- [66] Jiang Z, Ai Q, Hao R. Integrated DR mechanism for industrial energy system based on multi-energy interaction. *IEEE Access* 2019;7:66336–46. <https://doi.org/10.1109/ACCESS.2019.2917821>.
- [67] Aalami HA, Moghaddam MP, Yousefi GR. DR modeling considering Interruptible/Curtailable loads and capacity market programs. *Appl Energy* 2010;87:243–50. <https://doi.org/10.1016/j.apenergy.2009.05.041>.
- [68] Good N. Using behavioural economic theory in modelling of DR. *Appl Energy* 2019;239:107–16. <https://doi.org/10.1016/j.apenergy.2019.01.158>.
- [69] Moghaddam MP, Abdollahi A, Rashidinejad M. Flexible DR programs modeling in electricity markets. *Appl Energy* 2011;88:3257–69. <https://doi.org/10.1016/j.apenergy.2011.02.039>.
- [70] Yan N, Zhang B, Li W, Ma S. Hybrid energy storage capacity allocation method for active distribution network considering demand side response. *IEEE Trans Appl Supercond* 2019;29:1–4. <https://doi.org/10.1109/TASC.2018.2889860>.
- [71] Hou L, Li W, Zhou K, Jiang Q. Integrating flexible DR toward available transfer capability enhancement. *Appl Energy* 2019;251:113370. <https://doi.org/10.1016/j.apenergy.2019.113370>.
- [72] Delavari A, Kamwa I. Sparse and resilient hierarchical direct load control for primary frequency response improvement and inter-area oscillations damping. *IEEE Trans Power Syst* 2018;33:5309–18. <https://doi.org/10.1109/TPWRS.2018.2795462>.
- [73] Hui H, Ding Y, Song Y, Rahman S. Modeling and control of flexible loads for frequency regulation services considering compensation of communication latency and detection error. *Appl Energy* 2019;250:161–74. <https://doi.org/10.1016/j.apenergy.2019.04.191>.
- [74] Althaher S, Mancarella P, Mutale J. Automated DR from home energy management system under dynamic pricing and power and comfort constraints. *IEEE Trans Smart Grid* 2015;6:1874–83. <https://doi.org/10.1109/TSG.2014.2388357>.

- [75] Bhana R, Overbye TJ. The commitment of interruptible load to ensure adequate system primary frequency response. *IEEE Trans Power Syst* 2016;31:2055–63. <https://doi.org/10.1109/TPWRS.2015.2458936>.
- [76] Cai Y, Lin J, Wan C, Song Y. Stochastic bilevel trading model for an active distribution company with DGs and interruptible loads. *IET Renew Power Gener* 2017;11:278–88. <https://doi.org/10.1049/iet-rpg.2016.0364>.
- [77] Ma G, Cai Z, Xie P, Liu P, Xiang S, Sun Y, et al. A bilevel capacity optimization of an isolated microgrid with load demand management considering load and renewable generation uncertainties. *IEEE Access* 2019;7:83074–87. <https://doi.org/10.1109/ACCESS.2019.2924288>.
- [78] Zhang C, Xu Y, Dong ZY, Ma J. Robust operation of microgrids via two-stage coordinated energy storage and direct load control. *IEEE Trans Power Syst* 2017;32:2858–68. <https://doi.org/10.1109/TPWRS.2016.2627583>.
- [79] Wang B, Li Y, Ming W, Wang S. Deep reinforcement learning method for DR management of interruptible load. *IEEE Trans Smart Grid* 2020;11:3146–55. <https://doi.org/10.1109/TSG.2020.2967430>.
- [80] Mortaji H, Ow SH, Moghavvemi M, Almurib HAF. Load shedding and smart-direct load control using internet of things in smart grid DR management. *IEEE Trans Ind Appl* 2017;53:5155–63. <https://doi.org/10.1109/TIA.2017.2740832>.
- [81] Meng FL, Zeng XJ. A profit maximization approach to DR management with customers behavior learning in smart grid. *IEEE Trans Smart Grid* 2016;7:1516–29. <https://doi.org/10.1109/TSG.2015.2462083>.
- [82] Kushwaha P, Prakash V, Bhakar R, Yarangatti UR. PFR constrained energy storage and interruptible load scheduling under high RE penetration. *IET Gener, Transm Distrib* 2020;14:3070–7. <https://doi.org/10.1049/iet-gtd.2019.1059>.
- [83] Yoon AY, Kim YJ, Zakula T, Moon SI. Retail electricity pricing via online-learning of data-driven DR of HVAC systems. *Appl Energy* 2020;265:114771. <https://doi.org/10.1016/j.apenergy.2020.114771>.
- [84] Zhang J, Zhang P, Wu H, Qi X, Yang S, Li Z. Two-stage load-scheduling model for the incentive-based DR of industrial users considering load aggregators. *IET Gener, Transm Distrib* 2018;12:3518–26. <https://doi.org/10.1049/iet-gtd.2018.0089>.
- [85] Zhao J, Wan C, Xu Z, Wong KP. Spinning reserve requirement optimization considering integration of plug-in electric vehicles. *IEEE Trans Smart Grid* 2017;8:2009–21. <https://doi.org/10.1109/TSG.2016.2597098>.
- [86] Wang T, O'Neill D, Kamath H. Dynamic control and optimization of distributed energy resources in a microgrid. *IEEE Trans Smart Grid* 2015;6:2884–94. <https://doi.org/10.1109/TSG.2015.2430286>.
- [87] Kwac J, Kim JI, Rajagopal R. Efficient customer selection process for various DR objectives. *IEEE Trans Smart Grid* 2019;10:1501–8. <https://doi.org/10.1109/TSG.2017.2768520>.
- [88] Jalali A, Sepasian MS, Sheikh-El-Eslami MK. Undisruptive load curtailment scheme to ensure voltage stability margin. *IET Gener, Transm Distrib* 2019;13:1509–19. <https://doi.org/10.1049/iet-gtd.2018.5436>.
- [89] Luo F, Zhao J, Dong ZY, Tong X, Chen Y, Yang H, et al. Optimal dispatch of air conditioner loads in southern China region by direct load control. *IEEE Trans Smart Grid* 2016;7:439–50. <https://doi.org/10.1109/TSG.2014.2388233>.
- [90] Azimian M, Amir V, Javadi S. Economic and environmental policy analysis for emission-neutral multi-carrier microgrid deployment. *Appl Energy* 2020;277:115609. <https://doi.org/10.1016/j.apenergy.2020.115609>.
- [91] Li WT, Gubba SR, Tushar W, Yuen C, Hassan NU, Poor HV, et al. Data driven electricity management for residential air conditioning systems: an experimental approach. *IEEE Trans Emerg Top Comput* 2019;7:380–91. <https://doi.org/10.1109/TETC.2017.2655362>.
- [92] Haring TW, Mathieu JL, Andersson G. Comparing centralized and decentralized contract design enabling direct load control for reserves. *IEEE Trans Power Syst* 2016;31:2044–54. <https://doi.org/10.1109/TPWRS.2015.2458302>.
- [93] Cui Q, Wang X, Wang X, Zhang Y. Residential appliances direct load control in real-time using cooperative game. *IEEE Trans Power Syst* 2016;31:226–33. <https://doi.org/10.1109/TPWRS.2015.2391774>.
- [94] Wang Y, Ai X, Tan Z, Yan L, Liu S. Interactive dispatch modes and bidding strategy of multiple virtual power plants based on DR and game theory. *IEEE Trans Smart Grid* 2016;7:510–9. <https://doi.org/10.1109/TSG.2015.2409121>.
- [95] Parvania M, Fotuhi-Firuzabad M, Shahidehpour M. Optimal DR aggregation in wholesale electricity markets. *IEEE Trans Smart Grid* 2013;4:1957–65. <https://doi.org/10.1109/TSG.2013.2257894>.
- [96] Di Somma M, Graditi G, Siano P. Optimal bidding strategy for a DER aggregator in the day-ahead market in the presence of demand flexibility. *IEEE Trans Ind Electron* 2019;66:1509–19. <https://doi.org/10.1109/TIE.2018.2829677>.
- [97] Liu G, Xu Y, Tomsovic K. Bidding strategy for microgrid in day-ahead market based on hybrid stochastic/robust optimization. *IEEE Trans Smart Grid* 2016;7:227–37. <https://doi.org/10.1109/TSG.2015.2476669>.
- [98] Correa-Florez CA, Michiorri A, Kariniotakis G. Optimal participation of residential aggregators in energy and local flexibility markets. *IEEE Trans Smart Grid* 2020;11:1644–56. <https://doi.org/10.1109/TSG.2019.2941687>.
- [99] Wang J, Zhong H, Tang W, Rajagopal R, Xia Q, Kang C, et al. Optimal bidding strategy for microgrids in joint energy and ancillary service markets considering flexible ramping products. *Appl Energy* 2017;205:294–303. <https://doi.org/10.1016/j.apenergy.2017.07.047>.
- [100] Azizan Ruhi N, Dvijotham K, Chen N, Wierman A. Opportunities for price manipulation by aggregators in electricity markets. *IEEE Trans Smart Grid* 2018;9:5687–98. <https://doi.org/10.1109/TSG.2017.2694043>.
- [101] Khajeh H, Foroud AA, Firoozi H. Robust bidding strategies and scheduling of a price-maker microgrid aggregator participating in a pool-based electricity market. *IET Gener, Transm Distrib* 2019;13:468–77. <https://doi.org/10.1049/iet-gtd.2018.5061>.
- [102] Ramyar S, Liu AL, Chen Y. Power market model in presence of strategic prosumers. *IEEE Trans Power Syst* 2020;35:898–908. <https://doi.org/10.1109/TPWRS.2019.2937887>.
- [103] Bahramara S, Yazdani-Damavandi M, Contreras J, Shafie-Khah M, Catalão JPS. Modeling the strategic behavior of a distribution company in wholesale energy and reserve markets. *IEEE Trans Smart Grid* 2018;9:3857–70. <https://doi.org/10.1109/TSG.2017.2768486>.
- [104] Mahmoudi N, Saha TK, Eghbal M. Wind power offering strategy in day-ahead markets: employing DR in a two-stage plan. *IEEE Trans Power Syst* 2015;30:1888–96. <https://doi.org/10.1109/TPWRS.2014.2354571>.
- [105] Mahmoudi N, Saha TK, Eghbal M. Modelling DR aggregator behavior in wind power offering strategies. *Appl Energy* 2014;133:347–55. <https://doi.org/10.1016/j.apenergy.2014.07.108>.
- [106] Kou P, Liang D, Gao L, Gao F. Stochastic coordination of plug-in electric vehicles and wind turbines in microgrid: a model predictive control approach. *IEEE Trans Smart Grid* 2016;7:1537–51. <https://doi.org/10.1109/TSG.2015.2475316>.
- [107] Vayá MG, Andersson G. Self scheduling of plug-in electric vehicle aggregator to provide balancing services for wind power. *IEEE Trans Sustain Energy* 2016;7:886–99. <https://doi.org/10.1109/TSTE.2015.2498521>.
- [108] Mohammad N, Mishra Y. Coordination of wind generation and DR to minimise operation cost in dayahead electricity markets using bilevel optimisation framework. *IET Gener, Transm Distrib* 2018;12:3793–802. <https://doi.org/10.1049/iet-gtd.2018.0110>.
- [109] Xing H, Zeng P, Lin Z, Wu Q, Fu M. A decentralised bilevel control approach to wind power regulation via thermostatically controlled loads. *J Eng* 2019;2019:4874–8. <https://doi.org/10.1049/joe.2018.9238>.
- [110] Kaheh Z, Kazemzadeh RB, Sheikh-El-Eslami MK. Simultaneous consideration of the balancing market and day-ahead market in Stackelberg game for flexiramp procurement problem in the presence of the wind farms and a DR aggregator. *IET Gener, Transm Distrib* 2019;13:4099–113. <https://doi.org/10.1049/iet-gtd.2018.6666>.
- [111] Lin X, Trethewey D. Flexible ramping products. 2012.
- [112] Gržanić M, Capuder T. Coordinated scheduling of renewable energy balancing group. *Int J Electr Power Energy Syst* 2021;125:106555. <https://doi.org/10.1016/j.ijepes.2020.106555>.
- [113] Jiang Y, Xu J, Sun Y, Wei C, Wang J, Ke D, et al. Day-ahead stochastic economic dispatch of wind integrated power system considering DR of residential hybrid energy system. *Appl Energy* 2017;190:1126–37. <https://doi.org/10.1016/j.apenergy.2017.01.030>.
- [114] Abbasi MH, Taki M, Rajabi A, Li L, Zhang J. Coordinated operation of electric vehicle charging and wind power generation as a virtual power plant: a multi-stage risk constrained approach. *Appl Energy* 2019;239:1294–307. <https://doi.org/10.1016/j.apenergy.2019.01.238>.
- [115] Dai X, Li Y, Zhang K, Feng W. A robust offering strategy for wind producers considering uncertainties of DR and wind power. *Appl Energy* 2020;279:115742. <https://doi.org/10.1016/j.apenergy.2020.115742>.
- [116] Abada Ibrahim, Andreas Ehrenmann XL. ON the viability OF energy communities. 2016.
- [117] Lowitzsch J, Hoicka CE, van Tulder FJ. Renewable energy communities under the 2019 European Clean Energy Package – governance model for the energy clusters of the future? *Renew Sustain Energy Rev* 2020;122:109489. <https://doi.org/10.1016/j.rser.2019.109489>.
- [118] Koirala BP, van Oost E, van der Windt H. Community energy storage: a responsible innovation towards a sustainable energy system? *Appl Energy* 2018;231:570–85. <https://doi.org/10.1016/j.apenergy.2018.09.163>.
- [119] Terlouw T, AlSkaif T, Bauer C, van Sark W. Multi-objective optimization of energy arbitrage in community energy storage systems using different battery technologies. *Appl Energy* 2019;239:356–72. <https://doi.org/10.1016/j.apenergy.2019.01.227>.
- [120] Comodi G, Bartolini A, Carducci F, Nagarajan B, Romagnoli A. Achieving low carbon local energy communities in hot climates by exploiting networks synergies in multi energy systems. *Appl Energy* 2019;256:113901. <https://doi.org/10.1016/j.apenergy.2019.113901>.
- [121] El Geneidy R, Howard B. Contracted energy flexibility characteristics of communities: analysis of a control strategy for DR. *Appl Energy* 2020;263:114600. <https://doi.org/10.1016/j.apenergy.2020.114600>.
- [122] Liu X, Yan Z, Wu J. Optimal coordinated operation of a multi-energy community considering interactions between energy storage and conversion devices. *Appl Energy* 2019;248:256–73. <https://doi.org/10.1016/j.apenergy.2019.04.106>.
- [123] Aberilla JM, Gallego-Schmid A, Stamford L, Azapagic A. Design and environmental sustainability assessment of small-scale off-grid energy systems for remote rural communities. *Appl Energy* 2020;258:114004. <https://doi.org/10.1016/j.apenergy.2019.114004>.
- [124] Lu X, Liu Z, Ma L, Wang L, Zhou K, Feng N. A robust optimization approach for optimal load dispatch of community energy hub. *Appl Energy* 2020;259. <https://doi.org/10.1016/j.apenergy.2019.114195>.
- [125] Jafari A, Ganjeh Ganjehlou H, Khalili T, Bidram A. A fair electricity market strategy for energy management and reliability enhancement of islanded multi-microgrids. *Appl Energy* 2020;270. <https://doi.org/10.1016/j.apenergy.2020.115170>.
- [126] Barbour E, Parra D, Awwad Z, González MC. Community energy storage: a smart choice for the smart grid? *Appl Energy* 2018;212:489–97. <https://doi.org/10.1016/j.apenergy.2017.12.056>.
- [127] Hossain MA, Pota HR, Squartini S, Zaman F, Guerrero JM. Energy scheduling of community microgrid with battery cost using particle swarm optimisation. *Appl Energy* 2019;254:113723. <https://doi.org/10.1016/j.apenergy.2019.113723>.

- [128] Liu G, Jiang T, Ollis TB, Zhang X, Tomsovic K. Distributed energy management for community microgrids considering network operational constraints and building thermal dynamics. *Appl Energy* 2019;239:83–95. <https://doi.org/10.1016/j.apenergy.2019.01.210>.
- [129] Feng C, Wen F, You S, Li Z, Shahnia F, Shahidehpour M. Coalitional game-based transactive energy management in local energy communities. *IEEE Trans Power Syst* 2020;35:1729–40. <https://doi.org/10.1109/TPWRS.2019.2957537>.
- [130] Good N, Mancarella P. Flexibility in multi-energy communities with electrical and thermal storage: a stochastic, robust approach for multi-service DR. *IEEE Trans Smart Grid* 2019;10:503–13. <https://doi.org/10.1109/TSG.2017.2745559>.
- [131] Lilla S, Orozco C, Borghetti A, Napolitano F, Tossani F. Day-ahead scheduling of a local energy community: an alternating direction method of multipliers approach. *IEEE Trans Power Syst* 2020;35:1132–42. <https://doi.org/10.1109/TPWRS.2019.2944541>.
- [132] Ma L, Liu N, Zhang J, Wang L. Real-time rolling horizon energy management for the energy-hub-coordinated prosumer community from a cooperative perspective. *IEEE Trans Power Syst* 2019;34:1227–42. <https://doi.org/10.1109/TPWRS.2018.2877236>.
- [133] Xing X, Xie L, Meng H, Guo X, Yue L, Guerrero JM. Multi-time-scale energy management strategy considering battery operation modes for grid-connected microgrids community. *CSEE J Power Energy Syst* 2019;1–10. <https://doi.org/10.17775/cseejpes.2018.00880>.
- [134] Paudel A, Chaudhari K, Long C, Gooi HB. Peer-to-peer energy trading in a prosumer-based community microgrid: a game-theoretic model. *IEEE Trans Ind Electron* 2019;66:6087–97. <https://doi.org/10.1109/TIE.2018.2874578>.
- [135] Pourakbari-Kasmaei M, Asensio M, Lehtonen M, Contreras J. Trilateral planning model for integrated community energy systems and PV-based prosumers-A bilevel stochastic programming approach. *IEEE Trans Power Syst* 2020;35:346–61. <https://doi.org/10.1109/TPWRS.2019.2935840>.
- [136] Zhang F, Luo F, Dong Z, Liu Y, Ranzi G. Hierarchical energy management scheme for residential communities under grid outage event. *IET Smart Grid* 2020;3:174–81. <https://doi.org/10.1049/iet-stg.2019.0150>.
- [137] Su Z, Wang Y, Xu Q, Fei M, Tian YC, Zhang N. A secure charging scheme for electric vehicles with smart communities in energy blockchain. *IEEE Internet Things J* 2019;6:4601–13. <https://doi.org/10.1109/JIOT.2018.2869297>.
- [138] Wang Y, Wu X, Li Y, Yan R, Tan Y, Qiao X, et al. Autonomous energy community based on energy contract. *IET Gener, Transm Distrib* 2020;14:682–9. <https://doi.org/10.1049/iet-gtd.2019.1223>.
- [139] Zhou S, Hu Z, Gu W, Jiang M, Zhang X-P. Artificial intelligence based smart energy community management: a reinforcement learning approach. *CSEE J Power Energy Syst* 2019;1–10. <https://doi.org/10.17775/cseejpes.2018.00840>.
- [140] Qi J, Liu L, Shen Z, Xu B, Leung KS, Sun Y. Low-carbon community adaptive energy management optimization toward smart services. *IEEE Trans Ind Informatics* 2020;16:3587–96. <https://doi.org/10.1109/TII.2019.2950511>.
- [141] Lv C, Yu H, Li P, Zhao K, Li H, Li S. Coordinated operation and planning of integrated electricity and gas community energy system with enhanced operational resilience. *IEEE Access* 2020;8:59257–77. <https://doi.org/10.1109/ACCESS.2020.2982412>.
- [142] van Leeuwen G, AlSkaif T, Gibescu M, van Sark W. An integrated blockchain-based energy management platform with bilateral trading for microgrid communities. *Appl Energy* 2020;263:114613. <https://doi.org/10.1016/j.apenergy.2020.114613>.
- [143] Monsberger C, Fina B, Auer H. Profitability of energy supply contracting and energy sharing concepts in a neighborhood energy community: business cases for Austria. *Energies* 2021;14:921. <https://doi.org/10.3390/en14040921>.
- [144] Tushar W, Saha TK, Yuen C, Smith D, Poor HV. Peer-to-Peer trading in electricity networks: an overview. *IEEE Trans Smart Grid* 2020;11:3185–200. <https://doi.org/10.1109/TSG.2020.2969657>.
- [145] Afzal M, Huang Q, Amin W, Umer K, Raza A, Naeem M. Blockchain enabled distributed demand side management in community energy system with smart homes. *IEEE Access* 2020;8:37428–39. <https://doi.org/10.1109/ACCESS.2020.2975233>.
- [146] Chis A, Koivunen V. Coalitional game-based cost optimization of energy portfolio in smart grid communities. *IEEE Trans Smart Grid* 2019;10:1960–70. <https://doi.org/10.1109/TSG.2017.2784902>.
- [147] Cui S, Wang YW, Shi Y, Xiao JW. A new and fair peer-to-peer energy sharing framework for energy buildings. *IEEE Trans Smart Grid* 2020;11:3817–26. <https://doi.org/10.1109/TSG.2020.2986337>.
- [148] Jing R, Xie MN, Wang FX, Chen LX. Fair P2P energy trading between residential and commercial multi-energy systems enabling integrated demand-side management. *Appl Energy* 2020;262:114551. <https://doi.org/10.1016/j.apenergy.2020.114551>.
- [149] An J, Lee M, Yeom S, Hong T. Determining the Peer-to-Peer electricity trading price and strategy for energy prosumers and consumers within a microgrid. *Appl Energy* 2020;261:114335. <https://doi.org/10.1016/j.apenergy.2019.114335>.
- [150] Tushar W, Saha TK, Yuen C, Azim MI, Morstyn T, Poor HV, et al. A coalition formation game framework for peer-to-peer energy trading. *Appl Energy* 2020;261:114436. <https://doi.org/10.1016/j.apenergy.2019.114436>.
- [151] Jiang Y, Zhou K, Lu X, Yang S. Electricity trading pricing among prosumers with game theory-based model in energy blockchain environment. *Appl Energy* 2020;271. <https://doi.org/10.1016/j.apenergy.2020.115239>.
- [152] Tushar W, Saha TK, Yuen C, Morstyn T, McCulloch MD, Poor HV, et al. A motivational game-theoretic approach for peer-to-peer energy trading in the smart grid. *Appl Energy* 2019;243:10–20. <https://doi.org/10.1016/j.apenergy.2019.03.111>.
- [153] Li Z, Ma T. Peer-to-peer electricity trading in grid-connected residential communities with household distributed photovoltaic. *Appl Energy* 2020;278:115670. <https://doi.org/10.1016/j.apenergy.2020.115670>.
- [154] Nguyen S, Peng W, Sokolowski P, Alahakoon D, Yu X. Optimizing rooftop photovoltaic distributed generation with battery storage for peer-to-peer energy trading. *Appl Energy* 2018;228:2567–80. <https://doi.org/10.1016/j.apenergy.2018.07.042>.
- [155] Zhang C, Wu J, Zhou Y, Cheng M, Long C. Peer-to-Peer energy trading in a Microgrid. *Appl Energy* 2018;220:1–12. <https://doi.org/10.1016/j.apenergy.2018.03.010>.
- [156] Zhou Y, Wu J, Long C. Evaluation of peer-to-peer energy sharing mechanisms based on a multiagent simulation framework. *Appl Energy* 2018;222:993–1022. <https://doi.org/10.1016/j.apenergy.2018.02.089>.
- [157] Alam MR, St-Hilaire M, Kunz T. Peer-to-peer energy trading among smart homes. *Appl Energy* 2019;238:1434–43. <https://doi.org/10.1016/j.apenergy.2019.01.091>.
- [158] Zhang Z, Tang H, Wang P, Huang Q, Lee WJ. Two-stage bidding strategy for peer-to-peer energy trading of nanogrid. *IEEE Trans Ind Appl* 2020;56:1000–9. <https://doi.org/10.1109/TIA.2019.2958302>.
- [159] Wang S, Taha AF, Wang J, Kvaternik K, Hahn A. Energy crowdsourcing and peer-to-peer energy trading in blockchain-enabled smart grids. *IEEE Trans Syst Man, Cybern Syst* 2019;49:1612–23. <https://doi.org/10.1109/TSMC.2019.2916565>.
- [160] Morstyn T, Teytelboym A, McCulloch MD. Bilateral contract networks for peer-to-peer energy trading. *IEEE Trans Smart Grid* 2019;10:2026–35. <https://doi.org/10.1109/TSG.2017.2786668>.
- [161] Teotia F, Mathuria P, Bhakar R. Peer-to-peer local electricity market platform pricing strategies for prosumers. *IET Gener, Transm Distrib* 2020;14:4388–97. <https://doi.org/10.1049/iet-gtd.2019.0578>.
- [162] Seven S, Yao G, Soran A, Onen A, Mueen SM. Peer-to-Peer energy trading in virtual power plant based on blockchain smart contracts. *IEEE Access* 2020;8:175713–26. <https://doi.org/10.1109/access.2020.3026180>.
- [163] Paudel A, Sampath LPMI, Yang J, Gooi HB. Peer-to-Peer energy trading in smart grid considering power losses and network fees. *IEEE Trans Smart Grid* 2020;11. <https://doi.org/10.1109/tsg.2020.2997956>. 1–1.
- [164] Anoh K, Maharjan S, Ikpehai A, Zhang Y, Adebisi B. Energy peer-to-peer trading in virtual microgrids in smart grids: a game-theoretic approach. *IEEE Trans Smart Grid* 2020;11:1264–75. <https://doi.org/10.1109/TSG.2019.2934830>.
- [165] Zhang H, Zhang H, Song L, Li Y, Han Z, Poor HV. Peer-to-Peer energy trading in DC packetized power microgrids. *IEEE J Sel Area Commun* 2020;38:17–30. <https://doi.org/10.1109/JSAC.2019.2951991>.
- [166] Aznavi S, Fajri P, Shadmand MB, Khoshkbar-Sadigh A. Peer-to-Peer operation strategy of PV equipped office buildings and charging stations considering electric vehicle energy pricing. *IEEE Trans Ind Appl* 2020;56:5848–57. <https://doi.org/10.1109/TIA.2020.2990585>.
- [167] Grzanic M, Morales JM, Pineda S, Capuder T. Electricity cost-sharing in energy communities under dynamic pricing and uncertainty. *IEEE Access* 2021;1–1. <https://doi.org/10.1109/ACCESS.2021.3059476>.
- [168] Tushar W, Saha TK, Yuen C, Morstyn T, Masood N Al, Vincent Poor H, et al. Grid influenced peer-to-peer energy trading. *ArXiv* 2019;11:1407–18.
- [169] Khorasany M, Mishra Y, Ledwich G. A decentralized bilateral energy trading system for peer-to-peer electricity markets. *IEEE Trans Ind Electron* 2020;67:4646–57. <https://doi.org/10.1109/TIE.2019.2931229>.
- [170] Guerrero J, Chapman AC, Verbic G. Decentralized P2P energy trading under network constraints in a low-voltage network. *IEEE Trans Smart Grid* 2018;10:5163–73. <https://doi.org/10.1109/TSG.2018.2878445>.
- [171] Zhang Z, Li R, Li F. A novel peer-to-peer local electricity market for joint trading of energy and uncertainty. *IEEE Trans Smart Grid* 2020;11:1205–15. <https://doi.org/10.1109/TSG.2019.2933574>.
- [172] Tushar W, Saha TK, Yuen C, Liddell P, Bean R, Poor HV. Peer-to-Peer energy trading with sustainable user participation: a game theoretic approach. *IEEE Access* 2018;6:62932–43. <https://doi.org/10.1109/ACCESS.2018.2875405>.
- [173] Jogunola O, Wang W, Adebisi B. Prosumers matching and least-cost energy path optimisation for peer-to-peer energy trading. *IEEE Access* 2020;8:95266–77. <https://doi.org/10.1109/ACCESS.2020.2996309>.
- [174] Zhou Y, Wu J, Song G, Long C. Framework design and optimal bidding strategy for ancillary service provision from a peer-to-peer energy trading community. *Appl Energy* 2020;278:115671. <https://doi.org/10.1016/j.apenergy.2020.115671>.
- [175] Alkandari A, Sami AA, Sami A. Proposed DSO ancillary service processes considering smart grid requirements. *CIREN - Open Access Proc J* 2017;2017:2846–7. <https://doi.org/10.1049/oap-cired.2017.0054>.
- [176] Oureilidis K, Malamaki KN, Gallos K, Tsitsmelis A, Dikaikos C, Gkavanoudis S, et al. Ancillary services market design in distribution networks: review and identification of barriers. *Energies* 2020;13. <https://doi.org/10.3390/en13040917>.
- [177] Minniti S, Haque N, Nguyen P, Pemen G. Local markets for flexibility trading: key stages and enablers. *Energies* 2018;11. <https://doi.org/10.3390/en11113074>.
- [178] Villar J, Bessa R, Matos M. Flexibility products and markets: literature review. *Electr Power Syst Res* 2018;154:329–40. <https://doi.org/10.1016/j.epsr.2017.09.005>.
- [179] Eid C, Codani P, Perez Y, Reneses J, Hakvoort R. Managing electric flexibility from Distributed Energy Resources: a review of incentives for market design. *Renew Sustain Energy Rev* 2016;64:237–47. <https://doi.org/10.1016/j.rser.2016.06.008>.

- [180] Jin X, Wu Q, Jia H. Local flexibility markets: literature review on concepts, models and clearing methods. *Appl Energy* 2020;261:114387. <https://doi.org/10.1016/j.apenergy.2019.114387>.
- [181] Ramos A, De Jonghe C, Gómez V, Belmans R. Realizing the smart grid's potential: defining local markets for flexibility. *Util Pol* 2016;40:26–35. <https://doi.org/10.1016/j.jup.2016.03.006>.
- [182] Esmat A, Usaola J, Moreno MÁ. A decentralized local flexibility market considering the uncertainty of demand. *Energies* 2018;11. <https://doi.org/10.3390/en11082078>.
- [183] Olivella-Rosell P, Bullich-Massagué E, Aragüés-Peñalba M, Sumper A, Ottesen SØ, Vidal-Clos JA, et al. Optimization problem for meeting distribution system operator requests in local flexibility markets with distributed energy resources. *Appl Energy* 2018;210:881–95. <https://doi.org/10.1016/j.apenergy.2017.08.136>.
- [184] Bouloumpasis I, Steen D, Tuan LA. Congestion management using local flexibility markets: recent development and challenges. *Proc 2019 IEEE PES innov smart grid technol eur ISGT-europe 2019*. 2019. <https://doi.org/10.1109/ISGTEurope.2019.8905489>.
- [185] Hu J, Yang G, Ziras C, Kok K. Aggregator operation in the balancing market through network-constrained transactive energy. *IEEE Trans Power Syst* 2019;34:4071–80. <https://doi.org/10.1109/TPWRS.2018.2874255>.
- [186] Pan Z, Yu T, Li J, Qu K, Chen L, Yang B, et al. Stochastic transactive control for electric vehicle aggregators coordination: a decentralized approximate dynamic programming approach. *IEEE Trans Smart Grid* 2020;11:4261–77. <https://doi.org/10.1109/TSG.2020.2992863>.
- [187] Soares A, De Somer O, Ectors D, Aben F, Goyvaerts J, Broekmans M, et al. Distributed optimization algorithm for residential flexibility activation-results from a field test. *IEEE Trans Power Syst* 2019;34:4119–27. <https://doi.org/10.1109/TPWRS.2018.2809440>.
- [188] Morstyn T, Teytelboym A, McCulloch MD. Designing decentralized markets for distribution system flexibility. *IEEE Trans Power Syst* 2019;34:1–12. <https://doi.org/10.1109/TPWRS.2018.2886244>.
- [189] Torbaghan SS, Blaauwbroek N, Nguyen P, Gibescu M. Local market framework for exploiting flexibility from the end users. *Int Conf Eur Energy Mark EEM 2016; 2016-July*. <https://doi.org/10.1109/EEM.2016.7521304>.
- [190] Sousa T, Hashemi S, Andersen PB. Raising the potential of a local market for the reactive power provision by electric vehicles in distribution grids. *IET Gener, Transm Distrib* 2019;13:2446–54. <https://doi.org/10.1049/iet-gtd.2018.5947>.
- [191] Heinrich C, Ziras C, Syri ALA, Bindner HW. EcoGrid 2.0: a large-scale field trial of a local flexibility market. *Appl Energy* 2020;261:114399. <https://doi.org/10.1016/j.apenergy.2019.114399>.
- [192] Olivella-Rosell P, Lloret-Gallego P, Munné-Collado Í, Villafafila-Robles R, Sumper A, Ottesen SØ, et al. Local flexibility market design for aggregators providing multiple flexibility services at distribution network level. *Energies* 2018;11:1–19. <https://doi.org/10.3390/en11040822>.
- [193] Al-Jassim Z, Christoffersen M, Wu Q, Huang S, Del Rosario G, Corchero C, et al. Optimal approach for the interaction between DSOs and aggregators to activate DER flexibility in the distribution grid. *CIREN - Open Access Proc J* 2017;2017:1912–6. <https://doi.org/10.1049/oap-cired.2017.0307>.
- [194] De Zotti G, Pourmousavi SA, Madsen H, Kjolstad Poulsen N. Ancillary services 4.0: a top-to-bottom control-based approach for solving ancillary services problems in smart grids. *IEEE Access* 2018;6:11694–706. <https://doi.org/10.1109/ACCESS.2018.2805330>.
- [195] Lin J, Leung KC, Li VOK. Optimal scheduling with vehicle-to-grid regulation service. *IEEE Internet Things J* 2014;1:556–69. <https://doi.org/10.1109/JIOT.2014.2361911>.
- [196] Sortomme E, El-Sharkawi MA. Optimal combined bidding of vehicle-to-grid ancillary services. *IEEE Trans Smart Grid* 2012;3:70–9. <https://doi.org/10.1109/TSG.2011.2170099>.
- [197] Sortomme E, El-Sharkawi MA. Optimal scheduling of vehicle-to-grid energy and ancillary services. *IEEE Trans Smart Grid* 2012;3:351–9. <https://doi.org/10.1109/TSG.2011.2164099>.
- [198] Hoogvliet TW, Litjens GBMA, van Sark WGJHM. Provision of regulating- and reserve power by electric vehicle owners in the Dutch market. *Appl Energy* 2017;190:1008–19. <https://doi.org/10.1016/j.apenergy.2017.01.006>.
- [199] Knezovic K, Martinenas S, Andersen PB, Zecchino A, Marinelli M. Enhancing the role of electric vehicles in the power grid: field validation of multiple ancillary services. *IEEE Trans Transp Electrification* 2017;3:201–9. <https://doi.org/10.1109/TTE.2016.2616864>.
- [200] Aldik A, Al-Awami AT, Sortomme E, Muqbel AM, Shahidehpour M. A planning model for electric vehicle aggregators providing ancillary services. *IEEE Access* 2018;6:70685–97. <https://doi.org/10.1109/ACCESS.2018.2880443>.
- [201] Chen X, Leung KC. Non-cooperative and cooperative optimization of scheduling with vehicle-to-grid regulation services. *IEEE Trans Veh Technol* 2020;69:114–30. <https://doi.org/10.1109/TVT.2019.2952712>.
- [202] Jafari M, Gauchia A, Zhao S, Zhang K, Gauchia L. Electric vehicle battery cycle aging evaluation in real-world daily driving and vehicle-to-grid services. *IEEE Trans Transp Electrification* 2017;4:122–34. <https://doi.org/10.1109/TTE.2017.2764320>.
- [203] David AO, Al-Anbagi I. EVs for frequency regulation: cost benefit analysis in a smart grid environment. *IET Electr Syst Transp* 2017;7:310–7. <https://doi.org/10.1049/iet-est.2017.0007>.
- [204] Recalde Melo DF, Trippe A, Gooi HB, Massier T. Robust electric vehicle aggregation for ancillary service provision considering battery aging. *IEEE Trans Smart Grid* 2018;9:1728–38. <https://doi.org/10.1109/TSG.2016.2598851>.
- [205] Bañol Arias N, Hashemi S, Andersen PB, Træholt C, Romero R. Assessment of economic benefits for EV owners participating in the primary frequency regulation markets. *Int J Electr Power Energy Syst* 2020;120:105985. <https://doi.org/10.1016/j.ijepes.2020.105985>.
- [206] Faddel S, Aldeek A, Al-Awami AT, Sortomme E, Al-Hamouz Z. Ancillary services bidding for uncertain bidirectional V2G using fuzzy linear programming. *Energy* 2018;160:986–95. <https://doi.org/10.1016/j.energy.2018.07.091>.
- [207] Sarabi S, Davigny A, Courtecuise V, Riffonneau Y, Robyns B. Potential of vehicle-to-grid ancillary services considering the uncertainties in plug-in electric vehicle availability and service/localization limitations in distribution grids. *Appl Energy* 2016;171:523–40. <https://doi.org/10.1016/j.apenergy.2016.03.064>.
- [208] Al-Obaidi A, Khani H, Farag HEZ, Mohamed M. Bidirectional smart charging of electric vehicles considering user preferences, peer to peer energy trade, and provision of grid ancillary services. *Int J Electr Power Energy Syst* 2021;124:106353. <https://doi.org/10.1016/j.ijepes.2020.106353>.
- [209] University of Bath. Peer to peer smart energy distribution networks D2 . 3 report of alternative business opportunities and business models to facilitate P2P energy exchange document ID : deliverable title : responsible beneficiary. 2020.
- [210] Morstyn T, Farrell N, Darby SJ, McCulloch MD. Using peer-to-peer energy-trading platforms to incentivize prosumers to form federated power plants. *Nat Energy* 2018;3:94–101. <https://doi.org/10.1038/s41560-017-0075-y>.
- [211] Zhang K, Troitzsch S, Hanif S, Hamacher T. Coordinated market design for peer-to-peer energy trade and ancillary services in distribution grids. *IEEE Trans Smart Grid* 2020;11:2929–41. <https://doi.org/10.1109/TSG.2020.2966216>.
- [212] Orlandini T, Soares T, Sousa T, Pinson P. Coordinating consumer-centric market and grid operation on distribution grid. In: 2019 16th int. Conf. Eur. Energy mark.; 2019. p. 1–6. <https://doi.org/10.1109/EEM.2019.8916247>.
- [213] Poplavskaya K, Lago J, de Vries L. Effect of market design on strategic bidding behavior: model-based analysis of European electricity balancing markets. *Appl Energy* 2020;270:115130. <https://doi.org/10.1016/j.apenergy.2020.115130>.
- [214] Barbero M, Corchero C, Canals Casals L, Igualada L, Heredia FJ. Critical evaluation of European balancing markets to enable the participation of Demand Aggregators. *Appl Energy* 2020;264. <https://doi.org/10.1016/j.apenergy.2020.114707>.
- [215] Wang R, Hsu S-C, Zheng S, Chen J-H, Li XI. Renewable energy microgrids: economic evaluation and decision making for government policies to contribute to affordable and clean energy. *Appl Energy* 2020;274:115287. <https://doi.org/10.1016/j.apenergy.2020.115287>.
- [216] Gorman W, Jarvis S, Callaway D. Should I Stay Or Should I Go? The importance of electricity rate design for household defection from the power grid. *Appl Energy* 2020;262:114494. <https://doi.org/10.1016/j.apenergy.2020.114494>.
- [217] Ansarin M, Ghiassi-Farrokhfal Y, Ketter W, Collins J. The economic consequences of electricity tariff design in a renewable energy era. *Appl Energy* 2020;275:115317. <https://doi.org/10.1016/j.apenergy.2020.115317>.
- [218] Migliavacca G. TSO-DSO interactions and ancillary services in electricity transmission and distribution networks: modeling, analysis and case-studies. 2019. <https://doi.org/10.1007/978-3-030-29203-4>.
- [219] Gerard H, Energyville V, Rivero E, Energyville V, Six D, Energyville V. Basic schemes for TSO-DSO coordination and ancillary services provision. 2020.
- [220] Leclercq G, Pavesi M, Gueuning T, Ashouri A, Sels P, Geth F, et al. Network and market models 2019:1–201.
- [221] Delnooz A, Vanschoenwinkel J, Rivero E, Madina C. CoordiNet Deliverable D1.3: definition of scenarios and products for the demonstration campaigns, vols. 1–93; 2019.
- [222] IEE F. TDX-ASSIST D1. 1 state of the art - TSO-DSO interoperability. 2020.
- [223] Radi M. TDX-ASSIST D3.2 Use case definitions. 2020.
- [224] Kristov L, De Martini P, Taft JD. A tale of two visions: designing a decentralized transactive electric system. *IEEE Power Energy Mag* 2016;14:63–9. <https://doi.org/10.1109/MPE.2016.2524964>.
- [225] Kim SW, Pollitt MG, Kim J. A contractual framework for sharing balancing responsibility between transmission system operator and distribution system operators 1. 2018. <https://doi.org/10.13140/RG.2.2.14317.90083>.
- [226] Burger SP, Jenkins JD, Batlle C, Pérez-Arriaga LJ. Restructuring revisited: competition and coordination in electricity distribution systems working paper series. 2018.
- [227] Ecofys, Fraunhofer IWES. Smart-market-design in deutschen verteilnetzen. *Stud Im Auftrag von Agora Energiewende* 2017:156.
- [228] Barnes NS, Brinster PA, Fahey P. TSO-DSO report: an integrated approach to active system management. *Gift Child Today* 2009;28:24–9. <https://doi.org/10.4219/gct-2005-161>.
- [229] Platform PM. www.econstor.eu 2017.
- [230] Vicente-Pastor A, Nieto-Martin J, Bunn DW, Laur A. Evaluation of flexibility markets for retailer-dso-tso coordination. *IEEE Trans Power Syst* 2019;34:2003–12. <https://doi.org/10.1109/TPWRS.2018.2880123>.
- [231] Entso-e. Distributed flexibility and the value of TSO/DSO coordination, vols. 1–7; 2016.
- [232] Marija Miletić, Mirna Gržanić, Ivan Pavić, Tomislav Capuder, Hrvoje Pandžić. Dynamic electricity pricing tariffs: trade-offs for suppliers and consumers. *Mediterr. Conf. Power gener. Transm., distrib. Energy convers.*. 2020. Paphos, Cyprus.
- [233] HEPI - Hepi cjenik n.d. <https://hepi.hepi.hr/pocetna/boxovi-ispod-velike-slike/najpovoljnija-cijena-struje/sto-je-hepi/hepi-cjenik-74/74> (accessed March 23, 2021).
- [234] HEP ELEKTRA d.o.o. - Tarifne stavke (cijene) n.d. <https://www.hep.hr/elekt ra/kucanstvo/tarifne-stavke-cijene/1547> (accessed March 29, 2021).

- [235] Law on Renewable Energy Sources and Highly Effective Cogeneration in Croatia n.d. https://narodne-novine.nn.hr/clanci/sluzbeni/2015_09_100_1937.html (accessed March 26, 2021).
- [236] HEPI - Kupac korisnik postrojenja za samoopskrbu n.d. <https://hepi.hepi.hr/aktualno/vijesti/kupac-korisnik-postrojenja-za-samoopskrbu/218> (accessed March 29, 2021).
- [237] CROPEX - Croatian power exchange n.d. <https://www.cropex.hr/hr/trgovanja/dan-unaprijed-trziste/rezultati-dan-unaprijed-trzista.html> (accessed March 24, 2021).
- [238] SEAS-NVE electricity prices n.d. <https://energi.seas-nve.dk/el/> (accessed March 29, 2021).
- [239] Salg af Solcellestrøm - Solcellekonulenten.dk n.d. <https://solcellekonulenten.dk/salg-af-solcellestroem/> (accessed March 30, 2021).
- [240] Tariffer | Energinet n.d. <https://energinet.dk/El/Elmarkedet/Tariffer> (accessed March 22, 2021).
- [241] Market data | Nord Pool n.d. <https://www.nordpoolgroup.com/Market-data/1/Dayahead/Area-Prices/ALL1/Hourly/?view=table> (accessed March 26, 2021).
- [242] Modstrom dynamic electricity prices n.d. <https://www.modstroem.dk/privat/bliv-kunde/bliv-kunde-privat/?queryName=Klimapakke> (99,00 kr./md) (accessed March 26, 2021).
- [243] Kitzing L, Katz J, Schröder ST, Morthorst PE, Andersen FM. The residential electricity sector in Denmark. 2016.
- [244] One Luz: save with the fixed price per kWh tariff | Endesa n.d. <https://www.endesa.com/en/catalog/light/one/one-luz> (accessed March 26, 2021).
- [245] Efficiency 2 periods (DHA) tariff of active energy invoicing price n.d. https://www.esios.ree.es/en/analysis/1013?vis=1&start_date=01-01-2020T00%3A00&end_date=31-12-2020T23%3A50&compare_start_date=31-12-2019T00%3A00&groupby=hour&compare_indicators=1014 (accessed March 26, 2021).
- [246] One Luz Nocturnal Tariff | Endesa n.d. <https://www.endesa.com/en/catalog/light/one/tarifa-nocturna-en> (accessed March 26, 2021).
- [247] Analysis | ESIOS electricity · data · transparency n.d. https://www.esios.ree.es/en/analysis/1739?vis=1&start_date=29-03-2021T00%3A00&end_date=29-03-2021T23%3A00&compare_start_date=28-03-2021T00%3A00&groupby=hour&compare_indicators=1013, vol. 1014,1015 (accessed March 29, 2021).
- [248] Solar PV installation cost globally 2050 | Statista n.d. <https://www.statista.com/statistics/1118626/solar-pv-installation-cost-projection/> (accessed March 19, 2021).
- [249] IRENA. Electricity storage and renewables: costs and markets to 2030. 2017.
- [250] de Almeida Lucila, Cappelli Viola, Nikolas Klausmann A, Soest H van. Peer-to-Peer trading and energy community in the electricity market - analysing the literature on law and regulation and looking ahead. 2020.
- [251] Gržanić M, Morales JM, Pineda S, Capuder T. Electricity cost-sharing in energy communities under dynamic pricing and uncertainty. IEEE Access 2021;9: 30225–41. <https://doi.org/10.1109/ACCESS.2021.3059476>.

DSO and Aggregator Sharing Concept for Distributed Battery Storage System

Mirna Gržanić

University of Zagreb
Faculty of Electrical Engineering and
Computing
Zagreb, Croatia
mirna.grzanic@fer.hr

Tomislav Capuder

University of Zagreb
Faculty of Electrical Engineering and
Computing
Zagreb, Croatia
tomislav.capuder@fer.hr

Slavko Krajcar

University of Zagreb
Faculty of Electrical Engineering and
Computing
Zagreb, Croatia
slavko.krajcar@fer.hr

Abstract— Increase in electricity demand, mostly due to integration of new technologies electrifying heat and transport, as well as increasing share of distributed generation, create new challenges for distribution system operator (DSO) in terms of reliability and quality of power supply. This is particularly manifested during daily extremes, suggesting there is insufficient capacity of the distribution grid. To avoid expensive and unnecessary investments in new cables and transformers (since events that require network reinforcement are short and rare), the DSO can define a methodology for implementation of so called *non-grid solutions*. This paper analyses a concept in which the DSO signs a contract with the aggregator of flexible resources, offering incentives, such as reduced network fee, for using battery storage when necessary. Since the aggregator is looking for a feasible business case due to high investment cost of storage, the incentives given by the DSO provide a cost-effective investment for the aggregator. The aggregator uses battery storage to minimize the cost of purchasing electricity on the market while the DSO is utilizing it to postpone network reinforcement. The problem is cast as a bilevel problem where the operation of the distribution grid is modelled by *Second-Order-Cone-Programming (SOCP)* relaxation of optimal power flows bidding for the right to use aggregator's battery for preventing violating networks technical constraints. Over a set of scenarios, we demonstrate how coordinated usage of battery storage can postpone network reinforcement while ensuring secure power supply, as well as bring additional cost benefits for the aggregator.

Keywords—Aggregator, Battery Storage, Distribution System Operator, Reduced Network Fee, Second Order Cone Programming

I. INTRODUCTION

Priority of dispatch as well as feed-in tariffs are only a few of the mechanisms encouraging investments in renewable energy sources (RES), however they were the ones impacting the operation and planning of the distribution network, done by Distribution System Operator (DSO), the most. Former passive, or so called fit-and-forget, DSO approach was possible when radial distribution networks were characterized by unidirectional power flow from HV/MV transformer (connecting transmission and distribution network) supplying well-known consumption patterns of end-consumers. This concept was, on the other hand, based on oversizing the network to successfully capture all possible critical scenarios, such as congestion or unacceptable voltage deviation, without monitoring or real-time management.

Increasing number of end-consumers with installed PV, during the hours of net-production (when production from PV exceeds consumption) causes reverse power flows and even power flows from distribution to transmission network. Some critical scenarios may congest cables or overhead lines or even the HV/MV transformer, resulting in a need for network reinforcement. Since those critical scenarios are rare and short in duration, investments in new cables and transformers are unprofitable and could increase network losses. DSO faces those challenges through Active Distribution Network Management (ADNM) enabling more efficient network control and operation. On the other hand, as passive end-consumers now become active, an aggregator (or supplier/aggregator) will act on their behalf in the energy market, optimizing the portfolio and achieving the best electricity costs for its users. To increase its flexibility, and potentially profit, the aggregator might decide to invest into battery storage (BS) units and use them to perform arbitrage. Additional opportunities arise from the possibility of “renting” the BS to the DSO and providing a non-grid solution during critical scenarios described above. DSO will create price signals, depending on a number of objectives it can have in distribution network operation and control: power losses minimization [1-4], peak shaving [5-7], voltage control [8-11], maximization of renewable energy sources production [1], [12].

Aggregators participation in the electricity markets as coordinators of different entities is studied widely. The authors in [13] present Stackelberg game used for aggregator market participation and Nash Bargaining Game for optimizing the interaction between the aggregator and active consumers applied in the Belgium Power System. The bilevel model is used for maximizing the aggregators' profit, while minimizing the cost of each active consumer for purchasing energy, considering market-clearing process and resulting prices. The model described in [14] provides supplier participation on three different energy markets through Stackelberg Game. Its active consumers have inflexible loads which cannot be optimized, as well as flexible loads which are used for heating purposes. The results of a bilevel structured optimization model are prices given from the aggregator to consumers, maximizing aggregators profit and minimizing consumers cost of purchased energy. Three different types of prices are compared (dynamic, fixed and Time-of-Use) and the results show that the best solution is dynamic price system calculated for day-ahead, real-time and ex-post market. The paper [15] analyses individual

This work is supported in part by the Croatian Environmental Protection and Energy Efficiency Fund under the project Microgrid Positioning (uGRIP) from the ERA Net Smart Grids Plus funding scheme and by European Regional Development Fund through Interreg Danube Transnational Programme (DTP1-502-3.2-3Smart).

usage of battery storage by the system operator (peak load reduction) and supplier (arbitrage) with an additional combined case where system operator's objective function is presented as a constraint in supplier problem. The work in [16] describes mixed linear programming model in which households equipped with solar panels and battery storage want to minimize the cost of energy purchase and provide frequency response and reserve services. The authors in [17] present Italian Transmission System Operator (TSO) coordination with DSO who operates the active distribution network and interaction with the aggregator of distributed sources using advanced Information and Communication Technology (ICT). The aggregator can offer load shedding on the market to avoid 'alarm' state caused by the loss of generating units or outage of lines and substations. The model described in [18] presents potential negative impact of the aggregator, representing thermostatically controlled loads and electric vehicles, on DSO operation. The approach is based on calculating ranges of flexible consumption such that its performance does not violate grid technical constraints.

Unlike the available literature, the model described herein develops a concept cast as a bilevel Mixed Integer *SOCP* model, focusing on the shared role of battery storages in radial distribution network and describes how providing services to multiple distribution networks where providing services for multiple distribution network stakeholders adds to finding a profitable investment case and providing additional value of storage.

II. MODEL DESCRIPTION

A. Distribution network model

DistFlow model is based on the quadratic Kirchhoff Voltage Law (1-2) and the current on the line mn is calculated as (3):

$$U_{n,t}^2 = |U_{n,t}|^2 = |U_{m,t} - I_{mn,t}Z_{mn}|^2 \quad (1)$$

$$|U_{n,t}|^2 = |U_{m,t}|^2 - 2(r_{mn}P_{mn,t} + x_{mn}Q_{mn,t}) + |I_{mn,t}|^2(r_{mn}^2 + x_{mn}^2) \quad (2)$$

$$|I_{mn,t}|^2 = \frac{|S_{mn,t}|^2}{|U_{m,t}|^2} \quad (3)$$

Here $U_{n,t}$ and $U_{m,t}$ present voltage of the bus n and m , $I_{mn,t}$ current on the line mn flowing from bus m to n , Z_{mn} impedance of the line mn , r_{mn} resistance, x_{mn} reactance, $P_{mn,t}$ active power and $Q_{mn,t}$ reactive power flowing from bus m to n .

Equations listed above are non-linear and non-convex and thus cannot be solved using commercial solvers. *SOCP* was firstly introduced in [19] and later the exactness of the relaxations for radial grids are shown in [20-24]. *SOCP* relaxations of the problem are presented with (4-5):

$$u_{n,t} = u_{m,t} - 2(r_{mn}P_{mn,t} + x_{mn}Q_{mn,t}) + i_{mn,t}(r_{mn}^2 + x_{mn}^2) \quad (4)$$

$$P_{mn,t}^2 + Q_{mn,t}^2 \leq i_{mn,t}u_{m,t} \quad (5)$$

Variables u_n , u_m , i_{mn} present quadratic absolute values of variables U_n , U_m , I_{mn} . The voltage and current are limited with (6-7):

$$0.81u^{nominal} \leq u_{n,t} \leq 1.21u^{nominal} \quad (6)$$

$$i_{mn,t} \leq I_{MAX}^2 \quad (7)$$

DSO aims to postpone network reinforcement needed due to increased power consumption in distribution grid and peak load. Critical scenarios could be cable or HV/MV transformers overloads or unacceptable voltage drops.

The active and reactive power balance of load buses are shown in (8) and (9), while equations (10) and (11) present active and reactive power balance of slack bus:

$$load_{m,t}^{active} = \sum_{k \in K} (P_{km,t} - i_{km,t} \cdot r_{km}) - \sum_{n \in N} (P_{mn,t}) \quad (8)$$

$$load_{m,t}^{reactive} = \sum_{k \in K} (Q_{km,t} - i_{km,t} \cdot x_{km}) - \sum_{n \in N} (Q_{mn,t}) \quad (9)$$

$$P_{d,t} + \sum_{n \in N} (P_{mn,t}) = 0 \quad (10)$$

$$Q_{d,t} + \sum_{n \in N} (Q_{mn,t}) = 0 \quad (11)$$

$load_{m,t}^{active}$ and $load_{m,t}^{reactive}$ present active and reactive load at the bus m , $P_{d,t}$ is active power transferred from transmission to distribution network (the power bought at the market for supplying demand in that feeder by supplier/aggregator increased for the energy losses bought by the DSO), $Q_{d,t}$ is reactive power imported from MV network. The required service for voltage regulation is determined in DSO objective function (12) and sent to aggregator's problem as a fixed value:

$$\min \sum_{t \in T} cp_t \cdot provided\ service_t \quad (12)$$

cp_t is the price for charging or discharging battery required for voltage regulation based on market price or combined of reservation and activation price calculated from postponed network reinforcement pricing mechanism (described in Section V).

B. Aggregator model

The aggregator invests in several battery storages along the feeder and exploits their flexibility for arbitrage purposes. Since investment costs into battery storage units are still high, providing additional services to the DSO (e.g. either ancillary services incentives or reduced network fees) would help the aggregator to increase its profit and reduce the investment time. Aggregator's objective function is cost minimization (13) of energy procurement on the market with fixed values of contracted service (battery charging or discharging) providing to DSO:

$$\min \sum_{t \in T} mp_t \cdot P_{d,t} \quad (13)$$

mp_t stands for day-ahead market price of energy in hour t .

The active power-balance of end-consumers with installed battery storage is given with (14) and storage characteristics with (15-20):

$$-load_{m,t}^{active} + discharge_t - charge_t + \sum_{n \in N} (P_{mn,t}) = 0 \quad (14)$$

$$SOC_{m,t} = SOC_{m,t-1} + charge_{m,t} - discharge_{m,t} \quad (15)$$

$$SOC_0 = SOC_{24} = 0 \quad (16)$$

$$SOC_{m,t} \leq SOC^{max} \quad (17)$$

$$0 \leq charge_{m,t} \leq P^{max} \cdot x_t^{ch} \quad (18)$$

$$0 \leq discharge_{m,t} \leq P^{max} \cdot x_t^{dis} \quad (19)$$

$$x_t^{ch} + x_t^{dis} \leq 1 \quad (20)$$

$SOC_{m,t}$ is state of charge of battery storage m limited with battery capacity SOC^{max} , while charge and discharge are limited with P^{max} . Equation (16) shows that battery m is empty at the begin and end of the day. $x_{m,t}^{ch}$ and $x_{m,t}^{dis}$ are binary variables indicating charging or discharging actions which cannot be simultaneous (20). Figure 1 presents the model describing above equations.

Model shown in (1)-(20) describes the concept of battery units sharing, where the DSO is looking to find optimal bidding scheme which is more feasible than conventional grid solutions (such as new cables and transformers) while the aggregator improves its business case when compared to market services only. Feasibility of this approach is shown through savings analysis. The proposed model is tested on several case studies, based on realistic 400 V distribution network, reflecting different conditions which might occur in the network.

III. CASE STUDY

The model is tested on a radial low voltage (LV) 400V distribution grid (20 load buses and lines) which is connected with MV network through MV/LV transformer presented in Figure 2. Battery storages are located at the nodes 7,13,15,16 and 20. MV network and MV/LV transformer are modelled as a slack bus. Line parameters (connecting nodes, length, resistance, reactance and maximal rated current) are given in Table I, while cumulative demand profile from the whole feeder and market prices are presented in Figure 3:

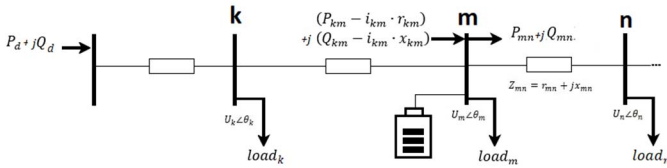

Figure 1 Power flow model

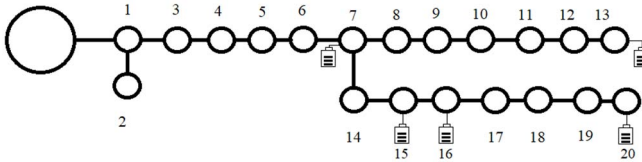

Figure 2 Topology of a single 400 V feeder in analyzed distribution network

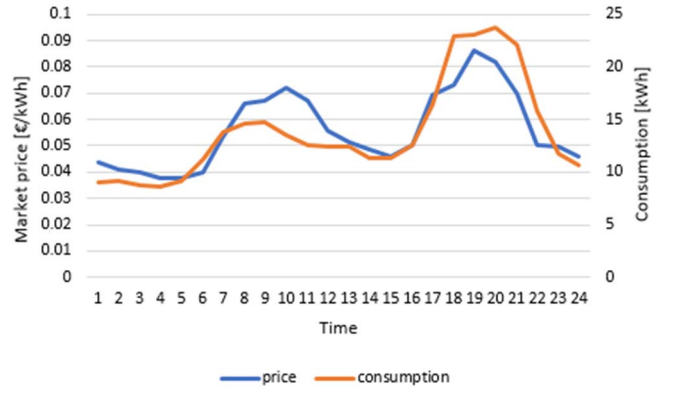

Figure 3 Market prices and cumulative consumption

TABLE I. LINE PARAMETERS

From	To	Length [km]	R [Ω/km]	X [Ω/km]	I _{max} [A]
0	1	0.064	0.308	0.281	283
1	2	0.1	0.595	0.302	185
1	3	0.113	0.833	0.313	149
3	4	0.135	0.595	0.302	185
4	5	0.135	0.595	0.302	185
5	6	0.044	0.595	0.302	185
6	7	0.092	0.437	0.302	226
7	8	0.1055	0.437	0.29	226
8	9	0.105	0.437	0.29	226
9	10	0.064	0.308	0.29	283
10	11	0.1545	0.308	0.281	283
11	12	0.0805	0.437	0.281	226
12	13	0.135	0.308	0.281	283
7	14	0.085	0.595	0.302	185
14	15	0.2595	0.833	0.313	149
15	16	0.105	0.437	0.29	226
16	17	0.061	0.308	0.281	283
17	18	0.1545	0.308	0.281	283
18	19	0.0625	0.308	0.281	283
19	20	0.1545	0.308	0.281	283

Several scenarios are analysed:

1. *Case 1*: Initial state of 400 V distribution feeder (before network reinforcement or battery storage);
2. *Case 2*: 400 V distribution feeder considering conventional approach of investing into new cable lines in order to improve the network voltage;
3. *Case 3*: 400V distribution feeder with 5 battery units installed by end-consumers. Energy is procured

through dynamic pricing scheme, while the DSO charges for storage services reflect market prices;

4. *Case 4*: 400 V distribution feeder with 5 battery storages owned by aggregator, providing ancillary services to the DSO and enabling battery usage for end-users with reduced ToU prices;

Each battery storage has 5kWh energy capacity and 0.5 kW charge/discharge power capability. End-consumers are charged for energy according to ToU price scheme with 0.07 €/kWh during the day (8-22h) and 0.09 €/kWh during the night (22-8h), while in reduced ToU with 0.06 €/kWh and 0.08€/kWh.

IV. RESULTS

Voltage profile in the case without any network reinforcement or battery storage investment of the critical nodes is shown in Figure 4.

As it can be seen from Figure 4, last six nodes on the feeder have issues as voltage drop is higher than 10% of the nominal value during hours of peak consumption (18th -21st hour). A conventional way of resolving this issue for DSO is cable investment (0.797 km of cable should be reinforced) which costs 31,880 €. Voltage profile with network reinforcement is shown in Figure 5.

An alternative option is to utilize a non-grid solution in form of battery storage and to improve the voltage profile while postponing the network reinforcement. Since these battery units are private property, bought and owned by end-consumers for arbitrage purpose, the DSO should “rent” their flexibility when required. Table II presents consumption decrease required by DSO, while the Figure 6 shows the voltage improvement when the end-consumers provide the flexibility services to the DSO and for arbitrage. As the price of battery storage is falling rapidly [25-26], the calculations are performed with the price of 200 €/kWh, but it should be noticed that the price is expected to fall below 100\$/kWh by 2025. Total investment of each storage system is 1000 €, and if discount rate of 5% and storage life time of 8 years are considered, the net present value of energy storage reduced to annual level is equal to 184.68 €.

The net present value of equipment investment is reduced to the annual level as (21):

$$Investment_{annual} = Investment \cdot \frac{(1 + R)^L}{L} \quad (21)$$

The second factor in (21) reduces the investment to the net present value with the discount rate R during the L period of time (in years) which is equal to the life time of the equipment. Dividing the net present value with expected life time of equipment, net present value is reduced to the annual level.

If end-consumers equipped with battery storages individually procure energy at ToU prices, the investment into storage is not economically feasible only for arbitrage purpose as seen from the Table III comparing the costs listed in second and fourth column. The fourth column presents the annual cost for energy procurement with discounted annual battery investment cost. On the other hand, if end-consumers jointly participate in the market through an aggregator, procure energy at market price and provide flexibility to the DSO, the investment in battery storage is profitable, as seen in Table IV.

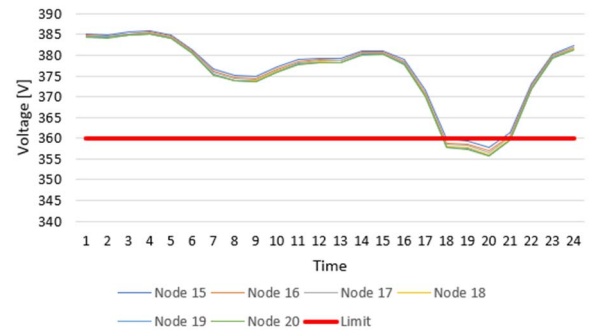

Figure 4 Voltage profile along the feeder

The price for providing services to the DSO is market price multiplied with coefficient 1.5. The value selected for this coefficient could be different, however the authors feel it will not be higher than 1.5, hence giving upper limit of profit.

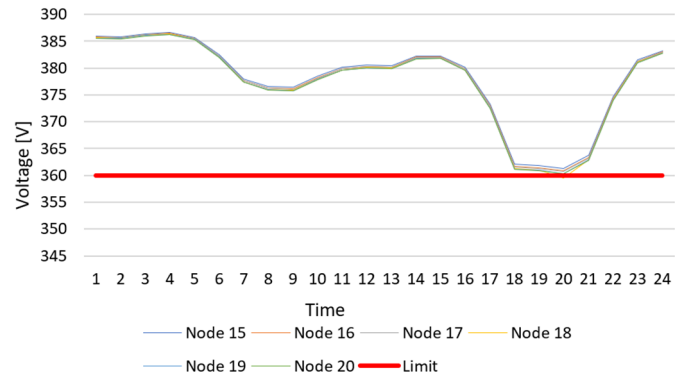

Figure 5 Improved voltage profile with cable reinforcement

TABLE II. REQUESTED FLEXIBILITY IN KW

Consumer	18 h	19 h	20 h	21 h
13	-	-	-	-
15	-	-	-0.5	-
16	-0.2703	-0.405	-0.5	-
20	-0.499	-0.499	-0.5	-0.146

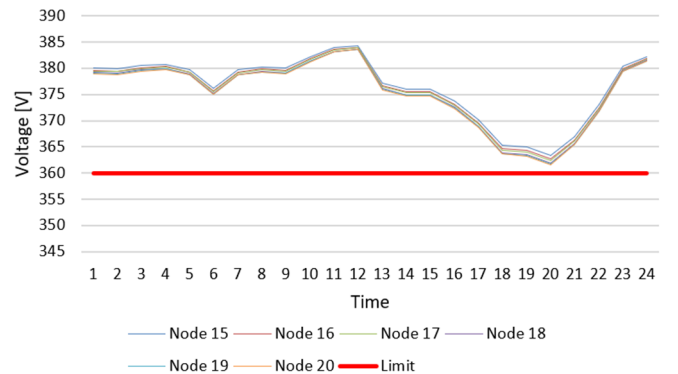

Figure 6 Improved voltage with battery storage activation

TABLE III. ANNUAL COSTS WITH TOU PRICES

Consumer	Energy cost without battery storage €	Energy cost with battery storage €	Cost including battery investment €
7	498.98	469.78	654.46
13	535.25	506.05	690.73
15	661.75	632.55	817.23
16	399.74	370.54	555.22
20	416.94	387.74	572.42

TABLE IV. ANNUAL COSTS WITH DYNAMIC PRICE AND SAVINGS

Consumer	Cost for energy €	Cost with battery investment €	Savings €
7	296.69	481.37	17.32
13	319.39	504.07	31.18
15	385.90	570.58	91.16
16	183.75	368.43	31.31
20	200.01	384.69	32.25

As it can be seen from Table IV, and compared to Table III, annual costs with storage units providing multiple services (including discounted battery investment cost) are lower than energy procurement cost without battery storage. Initial consumption of flexible consumers presented with lines and total battery charging and discharging presented with bars (arbitrage and ancillary services provided to DSO) are shown in Figure 7.

If end-consumers do not invest in battery storage as in private property, aggregator as the individual market participant could gather the group of potentially flexible end-consumers and offer them lower ToU prices to control their flexible consumption through charging and discharging of battery to reduce its energy procurement cost and provide services to the DSO. Costs and savings for consumers involved in demand response program with reduced ToU prices are shown in Table V.

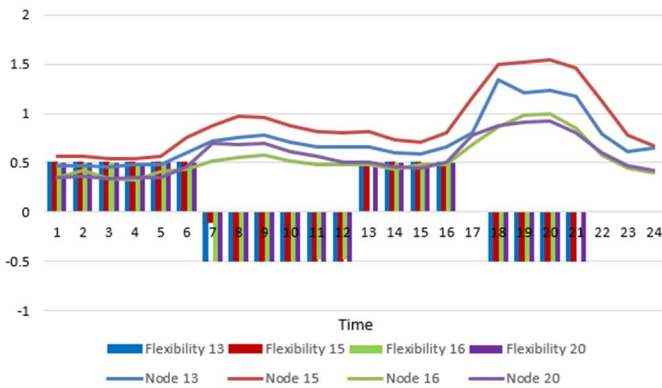

Figure 7 Initial consumption and provided flexibility

TABLE V. ANNUAL COSTS AND SAVINGS WITH REDUCED TOU PRICES

Consumer	Cost €	Savings €
7	437.52	61.46
13	473.41	61.84
15	585.72	76.03
16	347.48	52.26
20	363.79	53.15

V. FLEXIBILITY PRICES CALCULATION

Pricing mechanism for procuring flexibility from the end-consumers (or aggregator) can be based on market price, as done in previous section or calculated from postponed network reinforcement. Total investment cost in cables is 31,880 €. If an interest rate is 7% [27] and the inflation is 1.3% [28], the maximum price for flexibility for the first year ($t=1$), if the cable reinforcement is postponed, is calculated as follow (22):

$$Investment_{cost} - Investment_{cost} \cdot \frac{(1 + inflation)^t}{(1 + interest\ rate)^t} \quad (22)$$

The maximum price for flexibility is 1698.28 €. If the half is used for reservation fee, and the half for activation fee, the reservation price is calculated as (23):

$$Reservation\ price = \frac{Reservation\ fee\ [€]}{Total\ reserved\ capacity\ [kWh]} \quad (23)$$

The activation price is the same as the reservation price if the flexibility price is split in half for each one, but it is paid only if the service is activated.

For services provided as shown in Table II, the reservation price for reserved service (4 kWh each day which result in 1460kWh total over the entire year) is 0.58 €/kWh/activation. It has to be noticed that the DSO pays the reservation for required service for the entire discharging storage capacity. As a simplified way of calculating the income from providing DSO flexibility: consumer 16 has reserved 1.5 kWh capacity and reduces its consumption for 1.1753 kWh totally. Reservation profit is calculated as (24) and the activation as (25):

$$\frac{0.58€}{kWh} \cdot 1.5kWh \cdot 365\ reservations = 317.55\ € \quad (24)$$

$$\frac{0.58€}{kWh\ activation} \cdot 1.1753kWh \cdot 365 = 248.81\ € \quad (25)$$

The prices are based on a single-day calculation and more accurate results can be obtained from yearly analysis.

VI. CONCLUSION

Fit and forget approach, which implies that all problems are solved at the planning stage with oversizing the network to ensure secure and quality energy supply, becomes unreasonably expensive since potential network reinforcement could be postponed with integration of battery storages. Ownership of

battery storage by the DSO is questionably since they are a regulated system entity, however the end-consumers might decide to invest in batteries to reduce their electricity bill. The investment become profitable by renting and sharing battery capacity with DSO through incentives which are manifested through payments for providing ancillary services to the grid. The contributions presented in the paper are threefold:

- The model determines the required services for voltage regulation from the DSO and compares end-consumers savings through arbitrage only and providing services to the grid with several pricing schemes.
- Model compares conventional approach of new cable upgrade and battery storage integration through voltage improvement and cost savings.
- Two pricing mechanisms are presented and compared for DSO ancillary services favoring one based on postponed network reinforcement.

ACKNOWLEDGMENT

The authors would like to thank Katalin Decseine Giczi and Peter Gabor Mihaly from EON for guidance and advices in defining flexibility price calculation method described in Chapter V.

REFERENCES

- [1] J.F.Franco, "AC OPF for Smart Distribution Networks: An Efficient and Robust Quadratic Approach", IEEE Transactions on Smart Grid, 2017.
- [2] S. Carr, G. Premier, A. Guwy, R. Dinsdale, J. Maddy, "Energy storage for active network management on electricity distribution networks with wind power," IET Renew. Power Gener., vol. 8, no. 3, pp. 249–259, Apr. 2014
- [3] S. Ghasemi and J. Moshtagh, "A novel codification and modified heuristic approaches for optimal reconfiguration of distribution networks considering losses cost and cost benefit from voltage profile improvement," Appl. Soft Comput., vol. 25, pp. 360–368, Dec. 2014
- [4] A.Soroudi, P. Siano, A. Keane, "Optimal DR and ESS Scheduling for Distribution Losses Payments Minimization Under Electricity Price Uncertainty", IEEE Transactions on smart grid, vol. 7, no. 1, January 2016
- [5] S. Nykamp, A. Molderink, J. L. Hurink, and G. J. Smit, "Storage operation for peak shaving of distributed pv and wind generation", Innovative Smart Grid Technologies (ISGT), 2013 IEEE PES, IEEE, 2013, pp. 1–6.
- [6] P. Mercier, R. Cherkaoui, and A. Oudalov, "Optimizing a battery energy storage system for frequency control application in an isolated power system", Power Systems, IEEE Transactions on, vol. 24, no. 3, pp. 1469–1477, 2009.
- [7] A. Oudalov, R. Cherkaoui, and A. Beguin, "Sizing and optimal operation of battery energy storage system for peak shaving application", in Power Tech, 2007 IEEE Lausanne, IEEE, 2007, pp. 621–625.
- [8] A.Y.S.Lam, B.Zhang, A.Dominguez-Garcia, and D.Tse,"Optimal distributed voltage regulation in power distribution networks," IEEE Trans. Power Syst.
- [9] K. Turitsyn, P. Sulc, S. Backhaus, and M. Chertkov, "Local control of reactive power by distributed photovoltaic generators," in Proc. IEEE SmartGridComm, 2010, pp. 79–84.
- [10] D.K.Molzahn,B.C.Lesieutre,and C.L.DeMarco, "A sufficient condition for power flow insolvability with applications to voltage stability margins," IEEE Transactions on power systems, VOL. 28, NO. 3, AUGUST 2013
- [11] A. Zakariazadeh, O. Homae, S. Jadid, and P. Siano, "A new approach for real time voltage control using demand response in an automated distribution system," Appl. Energy, vol. 117, pp. 157–166, Mar. 2014.
- [12] F.Capitanescu, L. F. Ochoa, Harag Margossian, and N. D. Hatziaargyriou, "Assessing the Potential of Network Reconfiguration to Improve Distributed Generation Hosting Capacity in Active Distribution Systems", IEEE Transactions on power systems, VOL.30, NO.1, JANUARY 2015
- [13] K.Bruninx, H.Pandžić, H. Le Cadre, E. Delarue, "On controllability of Demand Response Resources & Aggregators' Bidding Strategies," PSCC 2018, June 11-15, 2018, Dublin, Ireland
- [14] M. Zugno, J.M. Morales, P.Pinson, H.Madsen, "A bilevel model for electricity retailers' participation in a demand response market environment," Energy Economics, Volume 36, March 2013
- [15] S. Nykamp, M. G. C. Bosman, A. Molderink, J. L. Hurink, G. J. M. Smit, "Value of Storage in Distribution Grids—Competition or Cooperation of Stakeholders?," IEEE Transactions on Smart Grid, vol. 4, no. 3, September 2013
- [16] T. Rodrigues, R. Moreira, G.Štrbac, "Coordinated operation of Distributed Energy Storage in Low Carbon Networks," 2017 IEEE PES General Meeting, Chicago, USA, July 2017
- [17] D.A. Sbordone, B.D. Pietra, E. M. Carlini, M. Devetsikiotis, "The Future Interaction between Virtual Aggregator-TSO-DSO to Increase DG Penetration," 2015 International Conference on Smart Grid and Clean Energy Technologies, Offenburg, Germany, October 2015
- [18] C. Heinrich, C. Ziras, S. You, H. W. Bindner, "Addressing the Conflict of Interest between Aggregators and DSOs in Deregulated Energy Markets," Proceedings of the 52nd International Universities' Power Engineering Conference, 2017, Crete, Greece, August 2017
- [19] C.Coffrin, H. L. Hijazi, P. Van Henemryck, "Network Flow and Copper Plate Relaxations for AC Transmission Systems", Power Systems Computation Conference, 2016
- [20] R. A. Jabr, "Radial Distribution Load Flow Using Conic Programming," IEEE Trans. Power Syst., vol.21, no.3, pp. 1458–1459, Aug. 2006
- [21] X. Bai, H. Wei, K. Fujisawa, and Y. Wang, "Semidefinite programming for optimal power flow problems," Int. J. Electr. Power Energy Syst., vol.30, no.6–7, pp. 383–392, Jul. 2008.
- [22] E. Dall'Anese, H. Zhu, G. B. Giannakis, "Distributed Optimal Power Flow for Smart Microgrids", IEEE Transactions on Smart Grid, volume: 4, issue: 3, pp 1464 – 1475, Sept. 2013
- [23] B. Zhang and D. Tse, "Geometry of feasible injection region of power networks," in Proc. 2011 49th Annual Allerton Conference on Communication, Control, and Computing (Allerton), pp. 1508–1515.
- [24] B. Zhang and D. Tse, "Geometry of injection regions of power networks," IEEE Trans. Power Syst., vol.28, no.2, pp. 788–797, May 2013.
- [25] <https://cleantechnica.com/2017/12/11/batteries-keep-getting-cheaper/>
- [26] <https://www.bloomberg.com/news/articles/2017-11-28/electric-cars-need-cheaper-batteries-before-taking-over-the-road>
- [27] <http://www.energetika-net.com/vijesti/obnovljivi-izvori-energije/trosak-kapitala-za-oie-medu-najvecim-u-eu-23907>
- [28] <https://www.dzs.hr/app/rss/stopa-inflacije.html>

Bi-level Modelling Approach to Coordinated Operation of Wind Power Plant and PV-Storage Energy Community

Mirna Gržanić

University of Zagreb
Faculty of Electrical Engineering and Computing
Zagreb, Croatia
mirna.grzanic@fer.hr

Tomislav Capuder

University of Zagreb
Faculty of Electrical Engineering and Computing
Zagreb, Croatia
Tomislav.capuder@fer.hr

Abstract— Uberization of the energy sector and transition towards decentralized, local production puts energy communities at the forefront of these changes. Very often they are initiators of new, low carbon investments and consequently they are becoming highly relevant market participants. This creates new power system operational challenges. The focus of this paper is on interplay and price driven collaboration between a PV-battery energy community and a wind power plant (WPP). This coordination is cast as a bilevel mixed integer linear programming (MILP) approach, modelling market participation of both entities, peer-to-peer (p2p) trading within energy community and power exchange between the energy community and WPP. The energy community is driven by the lowest energy cost for supplying its consumers, while the objective of a WPP is to maximize its profit. The results indicate that this coordination creates financial benefits for both sides as compared to individual market exposure.

Keywords— aggregator; energy community; bilevel MILP model; coordinated market participation; p2p trading; wind power plant

NOMENCLATURE

The notation used in this paper is provided below:

Indices and Sets:

$d \in D$ Households

$t \in T$ Time

Parameters:

$demand_{d,t}$ Demand of household d in hour t

p_{batmax} Max power of charging/discharging

p_{max_ex} Max export of household

p_{max_im} Max import of household

$p_{max_ext_M}$ Max export from household to market

$p_{max_imt_M}$ Max import from market to household

$p_{max_ex_total}$ Max export to market

$p_{max_im_total}$ Max import from market

P_t^W Wind production in hour t

$Price^{sell}$ Aggregator's selling price

$price_t^{buy}$ Aggregator's buying price in hour t

$PV_{d,t}$ PV production in household d in hour t

SOC^{max} Battery capacity

λ_t Market price for hour t

Variables:

$charging_{d,t}$ Total charging of battery d in hour t

$charging_{d,t}^{CHP}$ Charging battery d in hour t with energy produced from CHP

$charging_{d,t}^{im}$ Charging battery d in hour t with imported energy

$charging_{d,t}^{PV}$ Charging battery d in hour t with energy produced from PV

$CHP_{d,t}$ CHP production in household d in hour t

$CHP_{d,t}^{demand}$ Energy produced from CHP d for demand d in hour t

$CHP_{d,t}^{export}$ Energy produced from CHP d for export in hour t

$discharging_{d,t}$ Total discharging of battery d in hour t

$discharging_{d,t}^{dem}$ Discharging from battery d in hour t for satisfying demand

$discharging_{d,t}^{ex}$ Discharging from battery d in hour t for export

$Export_{d,t}$ Total export of household d in hour t

$Export_m^{HtoH}$	Export from household m to other households
$Export_{d,t}^{MARKET}$	Export from household d in hour t to the market
$Export_t^{total}$	Total export from all households in hour t to market
$Import_{d,t}$	Total household d import in hour t
$Import_{d,t}^{demand}$	Household d import in hour t for satisfying demand
$Import_m^{HtoH}$	Household m import from other households
$Import_{d,t}^{MARKET}$	Household d import from market in hour t
$Import_t^{total}$	Total import of all households in time t from the market
P_t^{AtoW}	Exported energy from aggregator to wind power plant in hour t
P_t^{WtoA}	Imported energy from wind power plant in hour t
$P_{d,t}^{AtoW}$	Exported energy from household d to wind power plant in hour t
$P_{d,t}^{WtoA}$	Imported energy from wind power plant to household d in hour t
$PV_{d,t}^{demand}$	Energy produced from PV d for demand d in hour t
$PV_{d,t}^{export}$	Energy produced from PV d for exprt in hour t
$SOC_{d,t}$	Battery d state of charge in hour t

Binary variables:

$u_t^1, u_t^2, u_t^3, u_t^4$	Auxiliary variables for linearization
x_t^{AtoW}	Indicates exported energy from aggregator to wind warm in hour t
$x_{d,t}^{ex}$	Indicates total exported energy from household d in hour t
$x_{d,t}^{im}$	Indicates total imported energy to household d in hour t
$x_{d,t}^{ex_MARKET}$	Indicates exported energy from household d to the market in hour t
$x_{d,t}^{im_MARKET}$	Indicates imported energy from the market for household d in hour t
$x_t^{ex_total}$	Indicates exported energy from all households to the market in time t
$x_t^{im_total}$	Indicates imported energy from the market to all households in time t
x_t^{WtoA}	Indicates imported energy from wind power plant in hour t

Dual variables:

$$\underline{\alpha}_t^{WtoA}, \bar{\alpha}_t^{WtoA}, \underline{\beta}_t^{AtoW}, \bar{\beta}_t^{AtoW}, \gamma$$

I. INTRODUCTION

Transformation of the power system from centralized bulk system to a decentralized one means active consumers start to perceive electricity as a commodity to be traded with. Reduction of prices for domestic micro units such as rooftop PV systems [1] go along with recent regulatory framework promoting the uptake of active consumers [2]. Numerous challenges arise in finding business cases for active consumers [3] (in the paper we refer to them as prosumers, despite the fact that this phrase is omitted in reference [4]), through aggregation and coordinated market participation with other market entities, creating additional value for all stakeholders [5]. These aspects have been the focus of recent research as shown in the following literature review. In [6] authors present mixed-integer linear programming model for optimizing joint bidding strategy of a WPP and energy storage facility that participate in day-ahead energy and spinning reserve markets. Uncertainty associated with renewable generation are reduced with coordination of service provision, as well as imbalance costs. Work of authors in [4] deals with coordinated operating strategy for ESS and PV equipped households while considering provision of balancing services to the system operator. The model presents how low carbon communities could become self-sufficient, and additionally, provide flexibility to the system operator. A bilevel framework for problem of decision-making by an EV aggregator in a competitive environment is proposed in [7] where the rivalry between an aggregator and EV owners is presented. The work in [8] applies game-theoretic principles to model competition between demand response aggregators for selling excess energy stored in electrochemical storage devices directly to other aggregators in a power market as alternative to the traditional vertically integrated market. Optimal operation of large-scale storage systems owned by independent private investors is studied in [9]. The paper proposes an optimal bidding mechanism for storage units in cases with large differences in market prices in the day-ahead and hour-ahead markets due to high penetration of intermittent renewable energy resources. Stochastic programming is used to present how fluctuations on the market can be improved with integration of large storage units and how location and size of the storage increase its profit. Bilevel problem of DR aggregator participation in wholesale markets is presented in [10]. The paper takes out that the existing profit from the deployment of DR contracts by aggregators will give revenues to the aggregator which can be used for end consumers. Interactions between the merchant DR aggregator and ES investor is presented in [11]. Results of equilibrium problem with equilibrium constraints (EPEC) show how their competition brings larger cost saving to the system, comparing to the case where only one technology is used. Acting strategically, both of them can increase own profitability. Bilevel model in [12] aims to minimize generation cost in upper level and maximize self-consumption of prosumers in lower level. High penetration of prosumers leads to improved voltage stability and flattened demand profile. The work in [13]

proposes plug-in electric vehicle aggregator exercising indirect load control over a fleet of vehicles and the decision-making process with determining the profit-optimal retail prices. Authors in [14] present a bilevel aggregator-utility optimization model with spot electricity prices for scheduling the energy consumption patterns of controllable loads classified in three diverse groups in the system with a high penetration of wind production showing improved energy efficiency and facilitated power balance considering intermittent wind production. Hierarchical structured multi-energy players cooperation exchanging energy with local energy system is developed in [15]. Bilevel approach is used for modeling the decision-making conflicts. Bilevel model in [16] describes DER aggregator decisions and managements of his clients with energy market participation. The paper presents how retail prices for his customers are determined, as well as the strategy for wholesale market participation. It can be noticed that none of the above papers addresses a joint coordinated market participation of energy community and renewable energy source such as WPP. In power systems where majority of electricity is produced from renewable sources, collaboration of such entities will be desirable. On one hand energy community has the capability to provide flexibility but is not prone to be exposed to volatile market prices. On the other hand, wind units can make significant profit by participating in power markets as a source of clean and low marginal cost energy, however they will mostly have to join a balancing group capable of mitigating their uncertain and variable production. This paper presents a bilevel model of a joint participation of a WPP and an energy community, acting as an aggregator of prosumers, at the energy market. Upper level problem describes aggregator cost which can be reduced by selling energy on the market and exchanging energy with the WPP. Lower level problem is wind farm profit maximization in cooperation with the aggregator. Selling more energy during period of high market prices will ensure higher profit for WPP. A bilevel model is latter described as a mathematical program with equilibrium constraints (MPEC) with upper level constraints, primal feasibility of lower level, stationarity, as well as dual feasibility of lower level problem and complementarity slackness. Fortuny-Amat Transformation is used for linearization and problem is solved using Gurobi solver.

II. MODEL DESCRIPTION

A. Model of energy community and wind power plant

The energy community is represented by two types of households characterized by specifics of units installed for local production. Similar model is presented in [4]. Conceptual scheme of the energy community and WPP is shown in Fig 1. The model is focused on the market cooperation, hence power system network constraints are not included in the model. One group of households is equipped with a PV panel and a battery storage, and the other group with a CHP unit and a battery storage. Thermal energy generation/demand is not explicitly modelled, meaning CHP units act as a generator with the cost of produced energy in satisfying electricity demand and assuming large enough thermal storage to decouple electricity and heat. Further work will be extended with realistic CHP unit

modelling of both electricity and thermal energy. Energy community acts as an aggregator of those two household groups and its cost function is modeled as (1):

$$\text{Min } \sum_{t \in T} (\text{price}^{\text{CHP}} \cdot \text{CHP}_t + \text{price}_t^{\text{buy}} \cdot \text{Import}_t^{\text{total}} - \text{price}^{\text{sell}} \cdot \text{Export}_t^{\text{total}}), \forall t \in T \quad (1)$$

The objective is to minimize total cost for procuring energy from CHP units and market while trying to gain profit by selling energy on the market in certain hours. In the initial case we consider constant selling price of 0.1 €/kWh, modelling a realistic case where energy community has a long-term contract with fixed prices to hedge the risk of volatile market prices. Aggregators buying price differs during night (22h-8h) 0.07 €/kWh and day hours (8h-22h) 0.14 €/kWh, describing a realistic case of two-tariff system as the most common contract between a retailer and final consumer. In the latter case the aggregator is exposed to day-ahead market prices. Marginal cost of energy produced from CHP unit is 0.03 €/kWh. Exchange of energy between the aggregator and WPP is done at zero cost, following the logic of coordinated participation with a common goal. This means that the WPP tries to maximize its profit by storing produced energy in energy communities' local battery storages during periods of low market prices. At the same time, the community benefits as it lowers its costs for energy procurement on the market and from CHP units. These relationships are described in the upper level model, with the following equations:

Each household d imports energy either from the market, WPP or from other households (2):

$$\text{Import}_{d,t} = \text{Import}_{d,t}^{\text{MARKET}} + P_{d,t}^{\text{WtoA}} + \sum_{m \in D} \text{Export}_m^{\text{HtoH}} \quad \forall d \in D, \forall t \in T \quad (2)$$

and exports energy to the market, WPP or other households (3):

$$\text{Export}_{d,t} = \text{Export}_{d,t}^{\text{MARKET}} + P_{d,t}^{\text{AtoW}} + \sum_{m \in D} \text{Import}_m^{\text{HtoH}} \quad \forall d \in D, \forall t \in T \quad (3)$$

Note that Equations (2) and (3) explicitly model exchange of energy between households within the community as p2p trading, ensuring the maximization of local consumption of locally produced low cost electricity (third member of Equations (2) and (3)).

Exchange with the market is limited for both import (4), as well as exported (5), as a way of modelling rated power of point of common coupling (PCC). Simultaneous import and export in the same hour are not possible (6):

$$\text{Import}_{d,t}^{\text{MARKET}} \leq P^{\text{max_im_M}} \cdot x_{d,t}^{\text{im_MARKET}} \quad \forall d \in D, \forall t \in T \quad (4)$$

$$\text{Export}_{d,t}^{\text{MARKET}} \leq P^{\text{max_ext_M}} \cdot x_{d,t}^{\text{ex_MARKET}} \quad \forall d \in D, \forall t \in T \quad (5)$$

$$x_{d,t}^{\text{im_MARKET}} + x_{d,t}^{\text{ex_MARKET}} \leq 1, \quad \forall d \in D, \forall t \in T \quad (6)$$

Similar is done for each household and limited by (7) and (8) without a possibility of simultaneous import and export in the same hour (9). These limitations are defined by the household connection power to the local distribution network:

$$\text{Import}_{d,t} \leq P^{\text{max_im}} \cdot x_{d,t}^{\text{im}} \quad \forall d \in D, \forall t \in T \quad (7)$$

$$\text{Export}_{d,t} \leq P^{\text{max_ex}} \cdot x_{d,t}^{\text{ex}} \quad \forall d \in D, \forall t \in T \quad (8)$$

$$x_{d,t}^{\text{im}} + x_{d,t}^{\text{ex}} \leq 1, \quad \forall d \in D, \forall t \in T \quad (9)$$

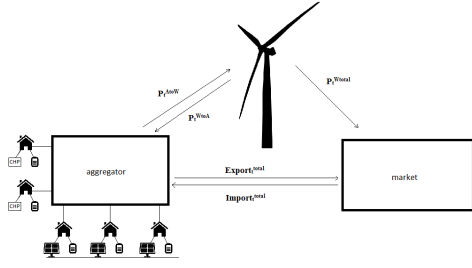

Figure 1 Coordinated market participation

Energy imported in each household is used for supplying demand and for battery charging (10):

$$Import_{d,t} = Import_{d,t}^{demand} + charging_{d,t}^{import} \quad \forall d \in D, \forall t \in T \quad (10)$$

Energy exported from each household is a result of battery discharging and energy produced from PV (11):

$$Export_{d,t} = discharging_{d,t}^{export} + PV_{d,t}^{export} \quad \forall d \in D, \forall t \in T \quad (11)$$

Demand is supplied from battery, PV (or CHP) and imported energy (12):

$$demand_{d,t} = discharging_{d,t}^{demand} + PV_{d,t}^{demand} + CHP_{d,t} + Import_{d,t}^{demand} \quad \forall d \in D, \forall t \in T \quad (12)$$

Production from PV is used for battery charging, demand supplying and export (13), as well as production from CHP (14):

$$PV_{d,t} = charging_{d,t}^{PV} + PV_{d,t}^{demand} + PV_{d,t}^{export} \quad \forall d \in D, \forall t \in T \quad (13)$$

$$CHP_{d,t} = charging_{d,t}^{CHP} + CHP_{d,t}^{demand} + CHP_{d,t}^{export} \quad \forall d \in D, \forall t \in T \quad (14)$$

Battery is charged with energy produced from PV (or CHP) and imported energy (15). Battery is discharged for demand supplying and export (16):

$$Charging_{d,t} = charging_{d,t}^{import} + charging_{d,t}^{PV} + charging_{d,t}^{CHP} \quad \forall d \in D, \forall t \in T \quad (15)$$

$$Discharging_{d,t} = discharging_{d,t}^{demand} + discharging_{d,t}^{export} \quad \forall d \in D, \forall t \in T \quad (16)$$

Charging and discharging actions are limited with maximum rate (17-18):

$$Charging_{d,t} \leq P^{batmax} \quad \forall d \in D, \forall t \in T \quad (17)$$

$$Discharging_{d,t} \leq P^{batmax} \quad \forall d \in D, \forall t \in T \quad (18)$$

Storage state of charge is expressed as (19):

$$SOC_{d,t} = SOC_{d,t-1} + 0.9 \cdot charging_{d,t} - discharging_{d,t} \quad \forall d \in D, \forall t \in T \quad (19)$$

Total export and import to or from the market in hour t is calculated as (20) and (21) and is limited by maximum export (22) and import (23). Simultaneous export and import in the same hour t are not allowed (24):

$$Export_t^{total} = \sum_{d \in D} export_d^{MARKET} \quad \forall t \in T \quad (20)$$

$$Import_t^{total} = \sum_{d \in D} import_d^{MARKET} \quad \forall t \in T \quad (21)$$

$$export_t^{total} \leq P^{max_ex_total} \cdot x_t^{ex_total} \quad \forall t \in T \quad (22)$$

$$import_t^{total} \leq P^{max_im_total} \cdot x_t^{im_total} \quad \forall t \in T \quad (23)$$

$$x_t^{im_total} + x_t^{ex_total} \leq 1, \quad \forall t \in T \quad (24)$$

Total exchanged energy between WPP and aggregator for each hour is given in (25) and (26) for both directions (WPP to aggregator and vice versa), as well as impossibility of simultaneous exchanging in both directions in the same hour t (27):

$$P_t^{WtoA} = \sum_{d \in D} P_{d,t}^{WtoA} \quad \forall t \in T \quad (25)$$

$$P_t^{AtoW} = \sum_{d \in D} P_{d,t}^{AtoW} \quad \forall t \in T \quad (26)$$

$$x_t^{WtoA} + x_t^{AtoW} \leq 1, \quad \forall t \in T \quad (27)$$

Lower level problem is WPP energy in hour t from WPP and exchanged energy between aggregator and WPP power plant (28):

$$\max \sum_{d \in D} (P_t^{WtoA} + P_t^{AtoW} - P_t^{WtoA}) \cdot \lambda_t, \quad \forall t \in T \quad (28)$$

For clarity, dual variables of the lower-level problem are listed after the corresponding constraints following a colon. Total energy produced by WPP is will be sold in the market and this is indirectly modelled by (29):

$$\sum_{t \in T} P_t^{WtoA} = \sum_{t \in T} P_t^{AtoW} : \gamma \quad (29)$$

What equation (29) refers to is the equality of total energy exchanged in both direction during a day, meaning that the total energy send from WPP to energy community needs to be equal to the one traded (at zero cost) in opposite direction. By modelling this, none of the two entities gains a favorable position compared to the other, the work in coordination and not as competing entities. Energy exchanged in both directions is limited with (30)-(33):

$$P_t^{WtoA} \geq 0 : \underline{\alpha}_t^{WtoA}, \quad \forall t \in T \quad (30)$$

$$P_t^{AtoW} \geq 0 : \underline{\beta}_t^{AtoW}, \quad \forall t \in T \quad (31)$$

$$P_t^{WtoA} \leq P^{maxAtoW} \cdot x_t^{WtoA} : \bar{\alpha}_t^{WtoA}, \quad \forall t \in T \quad (32)$$

$$P_t^{AtoW} \leq P^{maxWtoA} \cdot x_t^{AtoW} : \bar{\beta}_t^{AtoW}, \quad \forall t \in T \quad (33)$$

B. MPEC formulation

Model described in section A has a bilevel structure and cannot be solved using commercial solvers. It is converted into a mathematical program with equilibrium constraints (MPEC). The MPEC model is formulated as upper level problem (1-27), primal feasibility of lower level problem (29-33), stationarity (34-35) and dual feasibility and complementary slackness (36-39):

$$\gamma + \underline{\alpha}_t^{WtoA} - \bar{\alpha}_t^{WtoA} = \lambda_t, \quad \forall t \in T \quad (34)$$

$$-\gamma + \underline{\beta}_t^{AtoW} - \bar{\beta}_t^{AtoW} = -\lambda_t, \quad \forall t \in T \quad (35)$$

$$P_t^{WtoA} \geq 0 \perp \underline{\alpha}_t^{WtoA} \geq 0, \quad \forall t \in T \quad (36)$$

$$P^{maxAtoW} \cdot x_t^{WtoA} - P_t^{WtoA} \geq 0 \perp \bar{\alpha}_t^{WtoA} \geq 0, \quad \forall t \in T \quad (37)$$

$$P_t^{AtoW} \geq 0 \perp \underline{\beta}_t^{AtoW} \geq 0, \quad \forall t \in T \quad (38)$$

$$P^{maxWtoA} \cdot x_t^{AtoW} - P_t^{AtoW} \geq 0 \perp \bar{\beta}_t^{AtoW} \geq 0, \quad \forall t \in T \quad (39)$$

Conditions (36-39) are linearized using the Fortuny-Amat Transformations with the introduction of auxiliary binary variables and M as sufficiently large constant (40-47):

$$P_t^{WtoA} \leq M \cdot u_t^1, \quad \forall t \in T \quad (40)$$

$$\underline{\alpha}_t^{WtoA} \leq M \cdot (1 - u_t^1), \quad \forall t \in T \quad (41)$$

$$P^{maxWtoA} \cdot x_t^{WtoA} - P_t^{WtoA} \leq M \cdot u_t^2, \quad \forall t \in T \quad (42)$$

$$\bar{\alpha}_t^{WtoA} \leq M \cdot (1 - u_t^2), \forall t \in T \quad (43)$$

$$P_t^{AtoW} \leq M \cdot u_t^3, \forall t \in T \quad (44)$$

$$\beta_t^{AtoW} \leq M \cdot (1 - u_t^3), \forall t \in T \quad (45)$$

$$P_{maxAtoW} \cdot x_t^{AtoW} - P_t^{AtoW} \leq M \cdot u_t^4, \forall t \in T \quad (46)$$

$$\bar{\beta}_t^{AtoW} \leq M \cdot (1 - u_t^4), \forall t \in T \quad (47)$$

Finally, the model is described with (1-27), (29-33), (34-35) and (40-47).

III. CASE STUDY

Solar production for the first group of households is presented in Figure 2. Figure 3 shows demand profile of both groups of households. Demand 1-3 are households equipped with PV, and 4-6 with CHP unit. WPP production and market prices for three different cases are given in Fig 4. Households details are provided in Table I.

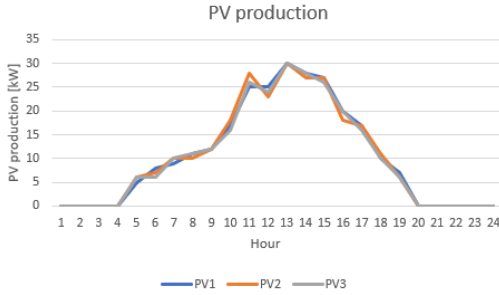

Figure 2 PV production

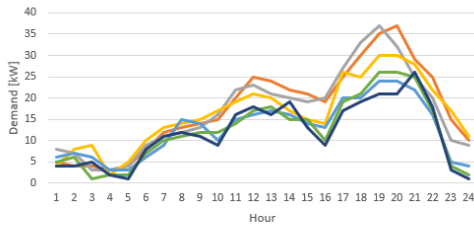

Figure 3 Demand profile

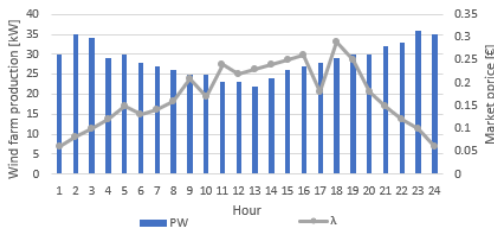

Figure 4 Wind power plant production and market prices

TABLE I. HOUSEHOLDS EQUIPMENT

Households	Battery	PV	CHP
1-3	5 kW/10 kWh	30 kW	-
4-6	5 kW/10 kWh	-	15 kW

IV. RESULTS

The results of the optimization are shown for a single day. However, the model can be easily expanded to cover any time period of interest. In the first case, fixed buying and selling prices for aggregator are considered, while in the second case the aggregator is exposed to the spot market prices (both selling and buying), and in the third case buying prices are dynamic market prices, and selling price is a fixed rate. WPP has higher profit (Table II) when coordinating its participation with the energy community in all cases. Table III compares aggregator independent cost with coordinated behavior. In the first case, aggregator's cost is lower in coordinated participation, as well as in third case with fixed selling price. In dynamic price scheme, WPP has the lowest profit increase, while aggregator cost is 0.54 % higher than in independent participation. In joint market participation, it pays off for WPP to sell more during 11th-16th hours when the first peak prices occur, meaning that aggregator will reduce its selling energy, but during the 18th-22nd hours, aggregator buys less than in independent participation. As active consumers share their storage with WPP, fixed buying and selling prices will reduce their exposure to volatile market prices and ensure lower energy procurement cost. Figure 5 presents aggregator export and import from (to) the market for coordinated cases. Negative values are exports to the market and positive ones are imports from the market. Figure 6 shows interchanged energy between aggregator and WPP for the first case. Negative values are exports from aggregator to wind power plant, and positive ones are imports from WPP. Interchanged energy between them is limited by 10 kWh per hour, although this again can be any value (or even a free variable). In 9th and during 11th-15th hours when market prices are highest, WPP imports energy from the aggregator and increases its own profit. During 17th-22nd hour, WPP imports the energy from the aggregator. It needs to be kept in mind that at the end of the day a balance between import and export needs to be maintained.

TABLE II. WIND POWER PLANT PROFIT

	Independent participation (€)	Coordinated participation (€)	Profit increase in %
Case 1	112.79	115.09	2.04
Case 2	112.79	113.18	0.35
Case 3	112.79	115.23	2.16

TABLE III. AGGREGATOR COST

	Independent participation (€)	Coordinated participation (€)
Case 1	89.55	87.15
Case 2	100.68	101.22
Case 3	117.04	111.61

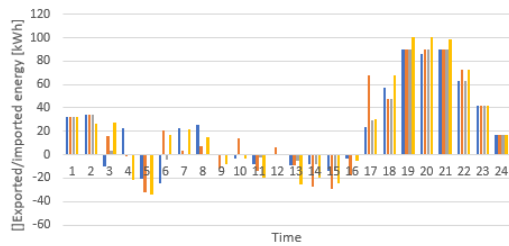

Figure 5 Energy import and export to (from) market

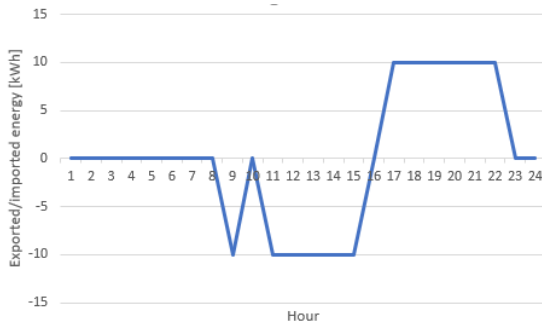

Figure 6 Imported and exported energy from the aggregator to the wind power Plant

V. CONCLUSION

Significant integration of renewable energy sources and small battery storages in the distribution system creates new opportunities for household market participation. Instead of only consuming the energy, households will become prosumers and, aggregated as a single market entity, capable of providing different services to the system or other market participants. The challenge lays in finding opportunistic business cases for new entities, especially when it comes to those with high levels of renewable generation in their portfolio. The novelty of the paper is in the bilevel model for coordinated participation of energy community, acting as an aggregator, and WPP in the energy market. The research has shown how joint participation brings benefits for both sides. For the sake of simplicity, the validity of the proposed business model is demonstrated by flexible joint participation on the day-ahead market only. Further research will focus on additional benefits which could arise from joint participation in multiple markets, such as adding balancing market participation to alleviate uncertainty of wind forecasts, as well as provision of multiple services to both market and system operator. From the results presented here, a reasonable assumption is that energy community aggregator will play a role of flexibility provider, reducing the imbalances caused by errors in forecasting generation from WPP but also its own households equipped with PV units. In such context, the energy communities take over the role of balancing group

leaders as they ensure equilibrium of schedules announced on a day-ahead and those delivered in real time markets. By doing this, they further increase the benefits of local prosumers, most likely seen as electricity bill reductions.

REFERENCES

- [1] Scientific American, The Price of Solar is Declining to Unprecedented Lows, <https://blogs.scientificamerican.com/plugged-in/the-price-of-solar-is-declining-to-unprecedented-lows/>
- [2] Clean Energy for all Europeans, http://europa.eu/rapid/press-release_IP-16-4009_en.htm
- [3] I. Pavić, M.Beus, H. Pandžić, T. Capuder, I.Štritof, "Electricity Markets Overview-Market Participation Possibilities for Renewable and Distributed Energy Resources," *14th International Conference on the European Energy Market (EEM) 2017*, 8-9 June, Dresden, Germany
- [4] T. Rodrigues, R. Moreira, and G.Strbac, "Coordinated Operation of Distributed Energy Storage in Low Carbon Networks," *22nd International Conference and Exhibition on Electricity Distribution (CIRED 2013)*, 10-13 June, Stockholm, Sweden
- [5] T. Capuder, P. Mancarella, "Assessing the benefits of coordinated operation of aggregated distributed multi-energy generation," *Power System Computation Conference (PSCC) 2016*, 20-24 June, Genoa, Italy
- [6] T. Rodrigues, P.J. Ramirez, and G.Strbac, "The Value of Storage for a Wind Farm Offering Energy and Spinning Reserve," *5th IET International Conference on Renewable Power Generation (RPG) 2016*, 21-23 Sept., London, UK
- [7] H.R.Kermani, M.V.Dahraie, H.R. Najafi, A.A.Moghaddam, J.M. Guerrero, "A stochastic Bi-Level Scheduling Approach for the Participation of EV Aggregators in Competitive Electricity Markets," *Applied Science* 2017,7,1100.
- [8] M. Motaleb, R.Ghorbani, "A Game-Theoretic Model of Demand Response Aggregator Competition for Selling Stored Energy in Regulated and Unregulated Power Markets," [arXiv:1612.00716v1](https://arxiv.org/abs/1612.00716v1)
- [9] H.A. Hejazi, H. M.Rad, "Optimal Operation of Independent Storage Systems in Energy and Reserve Market With High Wind Penetration", *IEEE TRANSACTIONS ON SMART GRID*, vol.5, no.2, March 2014, p 1088-1097
- [10] R. Henriquez, G. Wenzel, D.E.Olivares, M.N.Pincetic, "Participation of Demand Response Aggregators in Electricity Markets: Optimal Portfolio Management," *IEEE Transactions on Smart Grid*, accepted article
- [11] Y. Dvorkin, "Can Merchant Demand Response Affect Investments in Merchant Energy Storage," *IEEE Transactions on Power Systems*, accepted article
- [12] S. Riaz, H. Marzooghi, G. Verbič, A.C. Chapman, D.J.Hill, "Generic Demand Model Considering the Impact of Prosumers for Future Grid Scenario Analysis," *IEEE Transactions on Smart Grid*, accepted article
- [13] I. Momber, S. Wogrin, T.G.S.Roman, "Retail Pricing: A Bilevel Program for PEV Aggregator Decisions Using Indirect Load Control," *IEEE Transactions on Power Systems*, vol. 31, no. 1, January 2016, pp 464-473
- [14] K.K. Simon, J. Zhong, "Smart Dispatch of Controllable Loads with High Penetration of Renewables," *Transmission and Distribution Conference and Exposition (T&D), 2012 IEEE PES*, 7-10 May, Orlando, Florida, US
- [15] M. Y. Damavandi, N. Neyestani, G. Chicco, M. Shafie-khah, J.P.S. Catalao, "Aggregation of Distributed Energy Resources Under the Concept of Multienergy Players in Local energy Systems," *IEEE Transactions on Sustainable Energy*, vol 8, no 4, October 2017, pp 1679-1693
- [16] G.E. Asimakopoulou, N.D. Hatzigiorgiou, "Evaluation of Economic Benefits of DER Aggregation," *IEEE Transactions on Sustainable Energy*

Optimal Sizing of Battery Storage Units Integrated Into Fast Charging EV Stations

Vjekoslav Salapić, Mirna Gržanić, Tomislav Capuder

Department of Energy and Power Systems
University of Zagreb Faculty of Electrical Engineering and Computing
Zagreb, Croatia

vjekoslav.salapic@fer.hr, mirna.grzanic@fer.hr, tomislav.capuder@fer.hr

Abstract—The paper brings a mixed integer linear programming (MILP) solution for defining optimal size and operational strategy of battery storage systems (BSS) integrated with fast charging electric vehicle stations (FCS). The idea emerged as a solution for issues arising from strategies promoting installations of fast charging electric vehicle stations. Short, high power period peaks of fast charging increase the volatility of voltage in distribution networks and result in line congestions, requiring grid reinforcements by the distribution system operator (DSO). Additionally, transmission system operators (TSO) need to treat these power spikes, characterized by uncertainty of occurrence, by ensuring additional system flexibility. Coupling battery storage systems with FCS so that they serve as a buffer between the power system, reducing the stress of fast charging, and the electric vehicle (EV) users, providing the desired comfort in terms of charging speed, create multiple benefits for system participants. The results of the developed optimization model demonstrate that there is a feasible investment case for the proposed concept even in cases where only energy arbitrage is in place. Uncertainty aspects, such as unknown time of EV arrival or energy required by EVs, are considered for multiple locations where FCS are going to be installed.

Keywords—battery storage; electric vehicles; mixed integer linear programming; uncertainty;

NOMENCLATURE

Indices and Sets:

$t \in T$	Time
$i \in I$	Cars
$s \in S$	SOC scenarios
$v \in V$	Time scenarios

Parameters:

$Pch(t,s,v)$	Charging power of the BSS in minute t of SOC scenario s and time scenario v
$Pdis(t,s,v)$	Discharging power of the BSS into car in minute t of SOC scenario s and time scenario v

$SOC(t,s,v)$	State of charge of the BSS in minute t of SOC scenario s and time scenario v
$SOCcar(i,t,s,v)$	State of charge of the car i in minute t of SOC scenario s and time scenario v
$CarCapacity(i)$	Car i battery capacity
Bat_cap	Capacity of the BSS
$SOCmin$	Minimum BSS state of charge, dependant on battery technology
$Pmax(i)$	Maximum charging power of car i
Operational cost	Electricity cost for FCS with BSS
t_0	Beginning of charging process
t_e	End of charging process
$percentage_t_0(i,s,v)$	SOC percentage of car i at the beginning of charging process of SOC scenario s and time scenario v
$percentage_t_e(i,s,v)$	Demanded SOC percentage of car i at the ending of charging process of SOC scenario s and time scenario v

I. INTRODUCTION

Regulatory changes encouraging reduction of fossil fuel consumption and CO₂ emissions, in which personal vehicles have a large percentage, are causing a disruption in traditional way the power system has been planned and operated. The emerging growth of renewable energy source share in the energy mixes around the world is expected to be followed by electrification of transport [1]. While numbers of electric vehicles (EV) on roads today are still low, lessons learned from renewable energy sources (RES) integration suggest that disruptive technologies do not follow trend forecasts and similar patterns can be expected with EV. This goes hand in hand with goals, stated by several countries, of completely banning fossil fuel transportation in the upcoming years [2]. Vehicles powered by an electric motor have proved to be superior to Internal Combustion Engine (ICE) vehicles in both environmental (ICE are responsible for 12% of total CO₂ emission in the European

Union [3]) and driving experience aspect. The main disadvantages of EVs are their energy tanks, batteries, which today are still not comparable to conventional fuel tanks. To initiate the spark of transport electrification, the focus is put on installing publicly available fast charging electric vehicle stations at locations with frequent traffic. While this might encourage wider adoption of EV by final users, charging an EV at super-fast charging stations, with power up to 120 kW, may result in disturbance to the power grid such as power unbalances, voltage drops and frequency fluctuation [4]. The unpredictability of charging timetable, combined with high power demand for fast charging, enhances above mentioned problems. On the other hand, by increasing controllability and predictability of EV arrival and charging, the entire power system benefits from a new source of flexibility [5], [6], [7], [8]. This potentially is significant, as in 2015 there were 28.000 publicly available fast charging outlets [9] with numbers growing exponentially [10]. Due to the expected increase of EV stock [11], fast charging stations network will have to significantly expand. Therefore, it is necessary to find a solution for adequate integration of fast charging stations in the electric power system.

An interesting solution, analyzed in this paper, is integrating a battery storage system within the fast charging station. The battery storage system would serve as a buffer between the distribution grid (potentially also the transmission grid) and the final user. The charging power could be controllable and therefore much lower than if there was no battery within the FCS, while charging would occur even during periods when vehicles are not connected to the station, ensuring the battery storage system has sufficient energy to fast charge the EV when required. Several papers have proposed solutions for large scale integration of FCS, focusing mostly on planning [12], optimal placement [13] or market participation of aggregated FCS [14]. Some researchers have already considered integrating BSS with FCS, however they either focus on control strategies for such systems [15], or battery technology selection [16]. The only paper that deals with BSS optimal sizing and operational strategy, to the authors knowledge, is [17]. However, the authors of [17] neglect the uncertainty of EV arrival and state-of-charge (SOC) at the FCS as well as impact of injected power which is charged by the Distribution/Transmission System Operator (DSO/TSO).

In the line with the above, the paper brings the following contributions:

- We provide a mixed integer linear programming model for dimensioning the optimal capacity of the battery storage system integrated in the FCS. The model captures operating strategy for the BSS making sure the stress on the distribution grid (and consequently on the rest of the power system) is reduced while maintaining the desirable comfort level for the EV users. The model captures uncertainties related to time of arrival and state-of-charge of EV batteries.
- We assess the profitability of investment in such a charging station (with integrated BSS) for different locations and frequency of traffic and EV charging. It needs to be recognized that the investment is based on

both energy arbitrage and power taken from the network and charged by the system operator.

The paper is organized as follows: Section II describes modelling and optimization of BSS size, Section III shows the results of several scenarios and analyzes the impact of uncertainty parameters while Section IV provides most relevant conclusions.

II. MODEL DESCRIPTION

A. Optimization model

To evaluate the idea of a battery storage system within FCS, an optimization model is defined with technical and economic characteristics of the charging station. The mathematical model captures physical boundaries and possibilities of the charging station as well as that of BSS and arriving EVs.

The objective of the optimization model is to minimize the operational cost of electrical energy for charging EV. This objective is used since a significant cost difference can be achieved by buying electricity during low market prices. Prices used in this model are Day Ahead (DA) prices at EPEX SPOT [18] market. Operational cost is defined as following (1):

$$\text{Operational Cost} = \sum_{t=1}^T Pch(t) * DAprice(t) \quad (1)$$

To get another perspective of the economics, net present value (NPV) is calculated for each simulation (2). Calculating the NPV is an economics method of evaluating the profitability of an investment. NPV is the difference between the present value of cash inflows and the present value of cash outflows over a period of time [19]. To demonstrate the operational perspective, time step T is 1 hour for one full day, while in case of optimal decisions and NPV calculations, minimization of objective function is run over the entire year for 8760 hours.

$$NPV = -Investment + \sum_{i=1}^n \frac{Cashflow_i}{(1+r)^i} \quad (2)$$

Regular fast EV charging stations have direct grid connection, therefore they are billed, by their energy supply company, with a fee for the peak demanded power. In Croatia, for peak power above 20 kW, a monthly fee of 6€/kW for measured peak power has to be paid [20]. Therefore, absence of payment of this fee for integrated BSS and FCS will be included in calculating income as well as the difference between daily electricity cost for FCS with and without battery storage system.

The main outcome is the cost of investment in the battery storage. In this calculation, the battery price of 132 €/kWh is used [21]. Investment is approximated to last 10 years at discount rate of 5%. It should be noted that charging and discharging patterns have impact of the lifetime of BSS, however in this paper this is not considered.

B. FCS location and charging modelling

Several scenarios for modelling operational behavior are implemented by using stochastic programming, which allows modelling of imperfect knowledge of parameters. While in this

paper uncertainties are defined by probability distribution of each scenario, other probability distributions could be applied as well. The proposed concept is demonstrated for three different locations since every location is characterized by different patterns and schedules of car arrivals, based on specifics of the location. For each of the locations, the following parameters are inputs to the algorithm:

- Arrival time
- Departure time
- SOC at the time of arrival
- Requested SOC at end
- Type of car

Three popular locations for an EV charging station are described below. Default schedules for each location, as well as initial and final SOC of arriving cars are presented in Table I, II and III.

Location I: Charging station along the highway

- Open 0-24h
- Minimum charging time due to customers' wish to finish the trip as soon as possible

Location II: Charging station within a shopping center

- Open 07-22h
- Significantly longer charging time, 60-90 minutes, due to customers' shopping time habits

Location III: Charging station at a restaurant's parking lot

- Open 10-24h
- Rush hour for lunch time, 12-15h, and dinner time, 20-24h

TABLE I SCHEDULE OF ARRIVAL AT LOCATION I

Vehicle type	Arrival time	Departure time	Initial SOC	Final SOC
Tesla	02:00	02:45	35%	80%
BMW	04:00	04:30	20%	55%
VW	06:00	06:45	10%	85%
Tesla	07:30	08:15	10%	65%
Nissan	09:00	09:30	30%	70%
Tesla	10:00	10:30	30%	65%
VW	12:30	13:00	40%	85%
BMW	13:00	14:00	5%	95%
Tesla	15:30	16:15	20%	75%
Nissan	16:15	17:00	20%	80%
BMW	18:00	19:00	10%	80%
Nissan	19:00	20:00	25%	90%
VW	20:00	20:30	45%	80%
Tesla	21:30	22:00	20%	60%

VW	22:30	23:30	5%	60%
----	-------	-------	----	-----

TABLE II SCHEDULE OF ARRIVAL AT LOCATION II

Vehicle type	Arrival time	Departure time	Initial SOC	Final SOC
VW	07:00	08:00	15%	90%
Tesla	08:00	08:30	65%	85%
Nissan	09:30	10:30	30%	85%
Nissan	10:30	11:30	50%	90%
Tesla	12:00	13:30	5%	95%
BMW	14:30	15:30	40%	90%
VW	15:30	16:30	40%	80%
Tesla	17:00	18:00	50%	90%
Nissan	18:00	19:30	20%	95%
VW	20:30	21:30	25%	80%
Tesla	21:30	22:00	45%	65%

TABLE III SCHEDULE OF ARRIVAL AT LOCATION III

Vehicle type	Arrival time	Departure time	Initial SOC	Final SOC
BMW	10:00	10:30	25%	60%
Nissan	10:30	11:00	40%	70%
Tesla	12:00	12:45	40%	80%
Nissan	12:45	14:00	25%	90%
Tesla	14:00	15:00	55%	95%
BMW	17:00	18:00	55%	90%
BMW	19:15	20:00	20%	50%
Tesla	20:00	21:00	65%	95%
VW	21:00	22:00	30%	75%
VW	22:00	23:00	45%	95%
Nissan	23:00	24:00	10%	80%

Times of arrival and departure, as well as the initial SOC of the car battery are modelled as uncertain parameters. For example, in case of SOC, the parameters will deviate from the default values for a randomly defined value within limits. For time of arrival and departure these limits are defined as ± 15 minutes while initial SOC can vary up to $\pm 28\%$. There are total of 16 different scenarios and each scenario is equally probable.

Four different car models are used in this model, technical details are listed in Table IV:

TABLE IV CAR SPECIFICATIONS

Model	Battery capacity [kWh]	Maximum charging power [kW]
Tesla model S P85D	85	120
Volkswagen E-Golf	35.8	50
Nissan Leaf	30	50
BMW i3	33	50

For each car there is a different charging curve (3-6) that is approximated using available data [22], [23], [24], [25].

Tesla model S:

$$P_{dis}(t) = -1062 * \frac{SOC_{car}(Tesla,t)}{CarCapacity(Tesla)} + P_{max}(Tesla) \quad (3)$$

Volkswagen E-Golf

$$P_{dis}(t) = -250 * \frac{SOC_{car}(VW,t)}{CarCapacity(VW)} + P_{max}(VW) \quad (4)$$

Nissan Leaf

$$P_{dis}(t) = -420 * \frac{SOC_{car}(Nissan,t)}{CarCapacity(Nissan)} + P_{max}(Nissan) \quad (5)$$

BMW i3

$$P_{dis}(t) = -305 * \frac{SOC_{car}(BMW,t)}{CarCapacity(BMW)} + P_{max}(BMW) \quad (6)$$

C. FCS and battery modelling

BSS, within the charging station, is charged from the grid with power up to 19 kW in order to avoid additional costs for power and to reduce previously elaborated negative impacts on the distribution grid (7):

$$0 \text{ kW} \leq P_{ch}(t,s,v) \leq 19 \text{ kW} \quad (7)$$

The charging station is designed for fast charging with maximal output up to 120 kW, meaning the end-user, in this case the EV, can be charged with 120 kW from the BSS of FCS (8):

$$0 \text{ kW} \leq P_{dis}(t,s,v) \leq 120 \text{ kW} \quad (8)$$

The state of charge of the BSS can be from SOCmin to battery capacity (9):

$$SOC_{min} \leq SOC(t,s,v) \leq Bat_cap \quad (9)$$

BSS state of charge is defined as (10):

$$SOC(t,s,v) = SOC(t-1,s,v) + P_{ch}(t,s,v) - P_{dis}(t,s,v) \quad (10)$$

SOC of car i in time t is defined as SOC of the same car i in time $t-1$ plus charging of the car at that moment (11):

$$SOC_{car}(i,t,s,v) = SOC_{car}(i,t-1,s,v) + P_{dis}(t,s,v) \quad (11)$$

At the beginning of charging a vehicle, its SOC is defined as in (12):

$$SOC_{car}(i,t_0,s,v) = percentage_{t_0}(i,s,v) * CarCapacity(i) \quad (12)$$

Every vehicle must be charged to its demanded value (13):

$$SOC_{car}(i,t_e,s,v) = percentage_{t_e}(i,s,v) * CarCapacity(i) \quad (13)$$

Initial conditions at the beginning of the day are given with (14) and (15):

$$SOC(0,s,v) = 0 \quad (14)$$

$$P_{ch}(0,s,v) = 0 \quad (15)$$

III. RESULTS

A. Optimization results

Optimization results for each location are presented in Table V. Presented data shows operational cost of a single FCS with battery system and without battery system, lowest operational cost, battery size, maximum car charging power for given schedules and scenarios and minimum battery capacity, which is the minimum capacity required to meet all charging demands stated in schedules of arrivals in Tables I, II and III, including all possible uncertainty scenarios, with respect to defined constraints in Section II C.

TABLE V SIMULATION RESULTS

	Location I	Location II	Location III
Operational cost [€/year]	4993.20	3080.6	2062.25
Operational cost without BS [€/year]	5504.20	4263.2	3062.35
Battery capacity [kWh]	76.58	133.00	133.00
Maximum charging power [kW]	109.4	114.7	84.7
Minimum battery capacity [kWh]	39.50	48.00	30.50

Figure 1 presents battery charge (power from the distribution grid) and discharge power (power charging the EV), while Figure 2 presents SOC of battery and prices of electricity during a single day for one selected scenario in Location I.

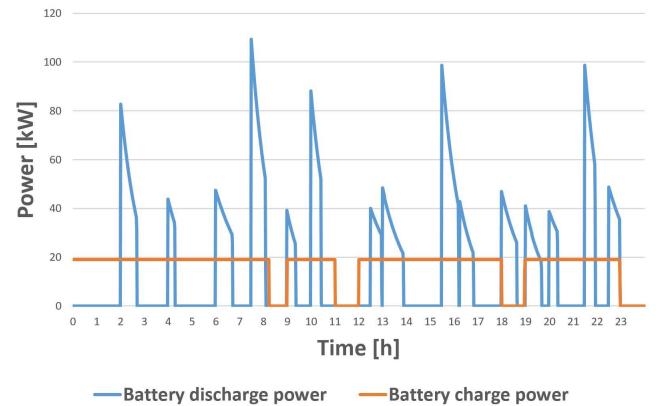

Figure 1 Battery charge and discharge power – Location I

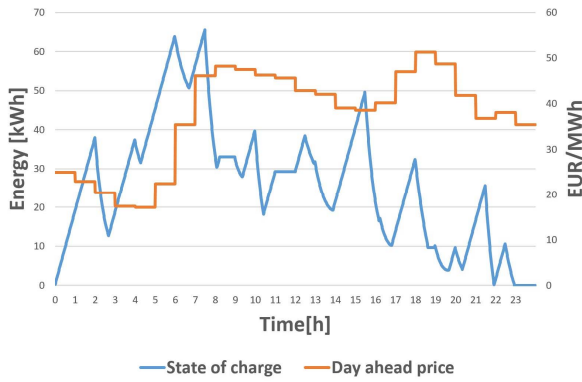

Figure 2 Battery SOC and electricity prices – Location I

As seen in Figures 1 and 2, battery was charged with maximum power during most hours of the day, trying to avoid periods of electricity peak prices. In case when only minimization of operational cost is considered as the objective function, without the investment cost of BSS, battery capacities are notably higher, up to 133 kWh. Batteries of these size cost a lot of money, but are not necessary to fulfill all EV charging demands during the day. To compare profits, simulations with the same objective as stated in (1), but including investment aspects are shown in the next subsection.

B. Optimal battery size considering investments

For each location six simulations are made. The starting size is the minimum capacity, as shown in Table 5 and explained in the previous paragraph, analyzing additional battery sizes in steps of 20 kWh capacity, namely: 55, 75, 95, 115 and 135 kWh. The results of minimum operational cost optimization are shown in Figure 3. Net present values are graphically presented in Figure 4. Higher battery capacity results in lower operational cost, since the potential to buy electricity during non-peak hours is greater with larger battery. On the other hand, batteries with larger capacity result in lower NPV. Highest NPV for all 3 locations is with the minimal battery capacity as shown in Figure 4.

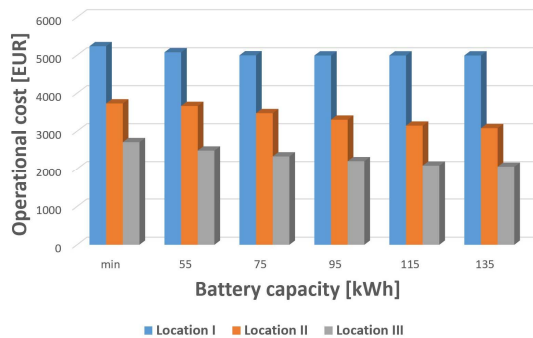

Figure 3 Yearly operational cost

C. Payback period

Another procedure used for economic evaluation is discounted payback period (DPP), giving insight into number of years for the discounted future cash flows to break even with initial investment. It is interesting to notice in Figure 5, where DPP for all observed locations and battery capacities are

presented, that the minimum size battery storage has a short payback period (under one year) for all analyzed scenarios.

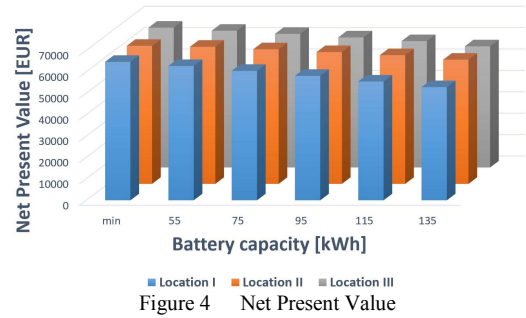

Figure 4 Net Present Value

D. Look into the future

Battery prices are expected to fall to 60€/kWh by 2030, according to [21]. It can also be assumed that EV stock will significantly increase and consequentially the usage of FCS will increase. Additional simulations to estimate fast charging in 2030 are made, with previously mentioned battery prices and 50% increase in number of EV served during a single day. It should be mentioned that an approximation was done here, taking same electricity prices as they are today (same as in previous simulations). Forecasting future market prices is outside of the scope of this paper.

FCS at Location I could not fulfill all the demands. Due to the BSS charging power limit to 19 kW, the FCS can daily deliver maximum 456 kWh of energy (which is equal to the product off BSS charging power limit and 24 hours). An increase of 50% in Location I means that total energy demand is higher than maximum possible.

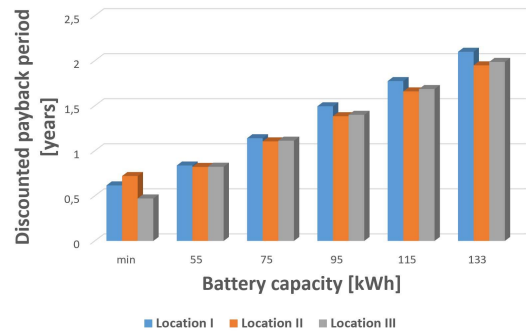

Figure 5 Discounted payback period

TABLE VI SIMULATION RESULTS FOR 2030

	Location I	Location II	Location III
Operational cost [€/year]	/	4901.95	3106.15
Operational cost without BS [€/year]	/	6007.90	4103.70
Battery capacity [kWh]	/	133.00	133.00
Minimum battery capacity [kWh]	/	87.40	50.50
Net present value [EUR]	/	67276	66430

FCS at locations II and III successfully delivered all requested energy. Operational cost, optimal battery capacity, minimum battery capacity and NPV for 2030 with predicted battery price of 60€/kWh are presented in Table VI. Again, the minimum size battery unit complying with all constraints is the optimal solutions considering both minimization of operational costs and investments. However, more frequent arrival schedule resulted in larger battery capacity. On the other hand, due to lower battery investment costs, NPVs have increased.

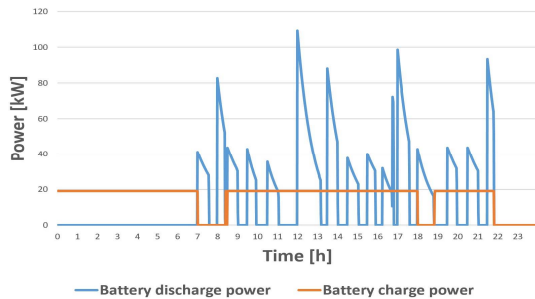

Figure 6 Battery charge and discharge power – Location II 2030

Figure 6 shows charging and discharging power for one scenario in Location II. It is shown that the BSS was charging from the distribution grid during more than 80% of the available time, so there is very little space for further increase of number of EVs charging in single day. It should be noted that the such frequent arrival schedules should also be an indicator for new FCS installations if the comport of EV owners is to remain the same.

IV. CONCLUSION

The proposed concept of integrating a battery storage system into EV fast charging station offers an additional level of controllability and flexibility to otherwise another source of uncertainty in future power systems. Despite the positive impact on the power grid as well as the electric power system, the question is if such an investment is feasible from the economic aspect. The analyses performed in this paper clearly show a positive NPV and DPP already for the smallest battery storage system that complies with technical constraints and does not compromise final EV user comfort. The operational strategy shows that installing BSS units results in steady and constant loading towards the upstream power system, however further quantifications have not been performed.

ACKNOWLEDGMENT

This work was supported in part by the Croatian Science Foundation under the project SUSTAINABLE CONCEPT for integration of distributed Energy Storage Systems (SUCCESS) and in part by the Croatian Science Foundation under the project Electric Vehicles Battery Swapping Station (IP-2014-09-3517).

REFERENCES

[1] "Electrification of the Transport System Studies and reports." [Online]. Available: https://www.ieee.org/about/ieee_europe/electrification_of_transportation_15_november_2017.pdf
 [2] A. Petroff, "These countries want to ban gas and diesel cars," *CNNMoney*,

2017. [Online]. Available: <http://money.cnn.com/2017/09/11/autos/countries-banning-diesel-gas-cars/index.html>
 [3] PBL Netherlands Environmental Assessment Agency and Joint Research Centre, "Trends in Global CO2 Emissions 2016 Report," pp. 6–86, 2016. [Online]. Available: http://edgar.jrc.ec.europa.eu/news_docs/jrc-2016-trends-in-global-co2-emissions-2016-report-103425.pdf
 [4] I. Pavić, T. Capuder, I. Kuzle, "A Comprehensive Approach for Maximizing Flexibility Benefits of Electric Vehicles," *IEEE Systems Journal*, August 2017 pp. 1–12, 2017.
 [5] T. Capuder, I. Kuzle, and I. Pavić, "Value of flexible electric vehicles in providing spinning reserve services," *Applied Energy*, vol. 157, pp. 60–74, 2015.
 [6] T. Capuder, I. Kuzle, and I. Pavić, "Low carbon technologies as providers of operational flexibility in future power systems," *Applied Energy*, vol. 168, pp. 724–738, 2016.
 [7] Y. Xiang, J. Liu, R. Li, F. Li, C. Gu, and S. Tang, "Economic planning of electric vehicle charging stations considering traffic constraints and load profile templates," *Applied Energy*, vol. 178, pp. 647–659, 2016.
 [8] F. Teng, Y. Mu, H. Jia, J. Wu, and P. Zeng, "Challenges of Primary Frequency Control and Benefits of Primary Frequency Response Support from Electric Vehicles," *Energy Procedia*, vol. 88, pp. 985–990, 2016.
 [9] International Energy Agency, "Global EV Outlook 2016 Electric Vehicles Initiative," *Iea*, p. 51, 2016. [Online]. Available: https://www.iea.org/publications/freepublications/publication/Global_EV_Outlook_2016.pdf
 [10] Chargemap, "Recharge stations statistics." [Online]. Available: <https://chargemap.com/about/stats>
 [11] I. E. A. International and E. Agency, "Global EV Outlook 2017 Two million and counting," 2017. [Online]. Available: <https://www.iea.org/publications/freepublications/publication/GlobalEVOutlook2017.pdf>
 [12] H. Zhang, S. J. Moura, Z. Hu, "A Second Order Cone Programming Model for Planning PEV Fast-Charging Stations," *IEEE Transactions on Power Systems*, vol. 8950, pp. 1–14, 2017.
 [13] Y. Xiong, J. Gan, B. An, C. Miao, and A. L. C. Bazzan, "Optimal Electric Vehicle Fast Charging Station Placement Based on Game Theoretical Framework," *IEEE Transactions on Intelligent Transportation Systems*, pp. 1–12, 2017.
 [14] M. R. Sarker, Y. Dvorkin, M. A. Ortega-Vazquez, "Optimal Participation of an Electric Vehicle Aggregator in Day-Ahead Energy and Reserve Markets," *Power and Energy Society General Meeting (PESGM)*, 2016, Boston, USA, vol. 31, no. 5, pp. 3506–3515, 2016.
 [15] B. Sun, T. Dragičević, F. D. Frejedo, J. C. Vasquez, J. M. Guerrero, "A Control Algorithm for Electric Vehicle Fast Charging Stations Equipped with Flywheel Energy Storage Systems," *IEEE Transactions on Power Electronics*, vol. 31, no. 9, pp. 6674–6685, 2016.
 [16] J. Deng, J. Shi, Y. Liu, and Y. Tang, "Application of a hybrid energy storage system in the fast charging station of electric vehicles," *IET Generation, Transmission & Distribution*, vol. 10, pp. 1092–1097, 2016.
 [17] S. Negarestani, M. Fotuhi-Firuzabad, M. Rastegar, A. Rajabi-ghahnavieh, "Optimal Sizing of Storage System in a Fast Charging Station for Plug-in Hybrid Electric Vehicles," *IEEE Transactions on Transportation Electrification*, vol. 2, no. 4, pp. 443–453, 2016.
 [18] EPEX, "Day-Ahead auction," *EPEXSPOT*, 2018. [Online]. Available: <https://www.epexspot.com/en/market-data>
 [19] Investopedia, "Net Present Value," *Net Present Value*. [Online]. Available: <https://www.investopedia.com/terms/n/npv.asp>
 [20] HEP, "Tarifne stavke(cijene)." [Online]. Available: <http://www.hep.hr/ods/korisnici/poduzetnistvo/tarifne-stavke-cijene-161/161>.
 [21] C. Curry, "Lithium-ion Battery Costs and Market," 2017. [Online]. Available: <https://data.bloomberglp.com/bnef/sites/14/2017/07/BNEF-Lithium-ion-battery-costs-and-market.pdf>
 [22] "Tesla Supercharger Charging Rate." [Online]. Available: <https://insideevs.com/tesla-ups-supercharger-charging-rate-refreshed-model-s-90d-p90d-video/>.
 [23] T. Saxton, "DC fast charging billing models and encouraging efficient usage." [Online]. Available: <https://chargedevs.com/features/dc-fast-charging-billing-models-and-encouraging-efficient-usage/>.
 [24] "E-Golf DC fast charging." [Online]. Available: <http://www.mywegolf.com/forum/viewtopic.php?f=12&t=444>.
 [25] "DC fast charging." [Online]. Available: http://electrifyatlanta.com/wp/?page_id=357.

The Value of Prosumers' Flexibility under Different Electricity Market Conditions: Case Studies of Denmark and Croatia

M. Gržanić¹, T. Capuder¹

¹Faculty of Electrical Engineering and Computing, University of Zagreb, Zagreb, Croatia
(mirna.grzanic@fer.hr, tomislav.capuder@fer.hr)

Abstract –To reduce greenhouse gas emissions, power system strategies have focused on large scale integration of renewable energy sources (RES) subsidizing initial installations for a fixed time period to ensure investment profitability. However, increasing number of wind and solar (PV) power plants, not responsible for scheduling deviations due to their intermittent production, resulted in growing need for power system flexibility. By rescinding incentives and subsidies and exposing RES to the market, they become responsible for accurate prediction of their production and become penalized for deviations from the announced forecasts.

Moreover, the suppliers, or the aggregators, will play an important role in unlocking and encouraging the flexible end-consumers with installed local RES and demand response (DR). They need to create market products in a form of different dynamic pricing schemes which award responsiveness to price signals and penalize passive behavior.

The paper focuses on the value of household flexibility through electricity cost reduction in low and high developed energy power markets. Results show that households equipped with PV and different types of DR programs in high-liquid market (as one in Denmark), exposed to the volatile market prices and responsible for their PV production and demand forecast, achieve lower electricity cost comparing to poorly developed retail market in Croatia where consumers are better off in a two-price tariff system.

Keywords - Demand response, dynamic pricing, market liquidity, renewable energy sources, two tariff pricing

NOMENCLATURE

Indices and Sets:

$d \in D$ Households

$s \in S$ Scenario

$t \in T$ Time

Parameters

\underline{E} Minimum state of charge of EV at the end of the day in kWh

\bar{E} Battery capacity of EV in kWh

F_{1-4} Coefficients of breakpoints used for piecewise linearization of battery maximum charging

L^{ap} Length of the cycle of uninterruptible appliances in hours (ap : washing machine, dryer, dish washer)

\bar{P} Maximum power of the EV charger in kW

$P^{uni\ ap}$ Power of each uninterruptible appliances in kW (ap : washing machine, dryer, dish washer)

R_{1-4} Coefficients of breakpoints used for piecewise linearization of battery maximum charging

\overline{SOC} Battery capacity in kWh

T_t^{max} Upper bound for the room temperature in time t in °C

T_t^{min} Lower bound for the room temperature in time t in °C

π_s Probability of scenario s

λ_t^{DA} DA market price in €/kWh

λ_t^b Buying price set by supplier in ToU pricing in €/kWh

λ_t^s Selling price set by supplier in ToU pricing in €/kWh

η Energy efficiency

Δt Time interval (1 hour)

Stochastic parameters

$P_{d,s,t}^{ms}$ Must-serve load d in scenario s and time t in kW

$PV_{d,s,t}$ PV production d in scenario s and time t in kW

$T_{s,t}^o$ Outside temperature in scenario s time t in °C

$\lambda_{s,t}^{DOWN}$ Down regulation price in scenario s and time t €/kWh

$\lambda_{s,t}^{UP}$ Up regulation price in scenario s and time t €/kWh

Variables

$P_{d,t}^b$ Power imported from the grid in ToU pricing in kW

$P_{d,t}^s$ Power exported to the grid in ToU pricing in kW

$P_{d,s,t}^{GRID}$ Power imported (positive) /exported (negative) to/from grid (household d scenario s time t) in kW

$P_{d,s,t}^{UP}$ Real time up regulation d in scenario s and time t in kW

$P_{d,s,t}^{DOWN}$ Real time down regulation d in scenario s and time t in kW

$P_{d,t}^{DA}$ Power contacted day ahead (household d time t) in kW

$P_{d,s,t}^{uni\ ap}$ Power of uninterruptible appliances ap in kW (household d scenario s time t)

$P_{d,s,t}^{def}$ Charging power of EV in kW (household d scenario s time t) -flexible deferrable load

$P_{d,s,t}^{th}$ Thermal load (household d scenario s time t) in kW

$P_{d,s,t}^{ch}$ Battery charging (household d scenario s time t) in kW

This work is supported in part by Croatian Science Foundation (HRZZ) through Climate change research program for period 2015-2016 supported by Government of Croatia project SUCCESS - Sustainable Concept for Integration of Distributed Energy Storage Systems and by the Croatian Environmental Protection and Energy Efficiency Fund under the project Microgrid Positioning (uGRIP) from the ERA Net Smart Grids Plus funding scheme

$P_{d,s,t}^{dis}$	Battery discharging (household d scenario s time t) in kW
$SOC_{d,s,t}$	Battery d state of charge in scenario s and time t in kWh
$T_{d,s,t}^{floor}$	Floor temperature in °C (household d scenario s time t)
$T_{d,s,t}^{room}$	Room temperature in °C (household d scenario s time t)
$T_{d,s,t}^{water}$	Water temperature in °C (household d scenario s time t)
$\Delta SOC_{d,s,t}$	Maximum energy charging ability of the battery (household d scenario s time t in kWh)

Binary variables

$b_{d,s,t}^i$	auxiliary binary variable determining the piecewise line segment on which $SOC_{d,s,t}$ lies
$x_{d,s,t}^{def}$	1 if EV in household d is being charged in scenario s and time t
$x_{d,s,t}^{uni ap}$	1 if uninterruptable flexible appliance ap in household d starts the cycle in scenario s and time t

I. INTRODUCTION

As the subsidy period of early installed renewable energy sources (RES) is coming to an end, development of new models and concepts to continue increasing the share of RES in future power systems is required. RES become balancing responsible parties and face penalties for their unscheduled production. Wind power plants cooperate with energy storages to increase the overall revenue by enabling more regulation capacities without harming battery's life [1]. Selecting the optimal capacity of battery storage can also lead to decreasing wind power curtailment, as well as reduce costs caused by curtailment [2]. Reduction of system operational costs and capacity increase of installed wind power plant ensuring system stability in [3] are carried out with cooperation of wind power plant with conventional generation and energy storage in hybrid power station on Greek isolated Samos Island. Coordination of a wind farm with a battery storage system based on modular multilevel converter in [4] with active and reactive power compensation results in smoothed power fluctuation, as well as in improved voltage at the bus of connected wind farm. The above concepts, and many others, show how coordinated operation of RES and flexibility units can reduce the uncertain and variable RES production and benefit the overall system costs and emissions.

When it comes to end-consumers with smaller installed capacity of renewable energy sources (such as rooftop solar panels PV), numerous approaches were considered to reduce consumer electricity cost either through integration of small-scale storage units or by deploying demand response (DR) programs. For example, in [5] optimal size of PV and household battery is defined

with the goal of reducing annual electricity cost. The model compares results of time-of-use tariffs and real-time pricing, as well as stepwise power tariff, and includes subsidies of PV. The results show two things: i) in absence of peak-valley prices households do not need battery storage; ii) the integration and size of PV depends on subsidies. The authors of [6] show that DR programs under dynamic price mechanism with installed PV reduce the voltage deviation and smooth the load profile, as well as improve voltage stability. In [7] the authors defined several sizes of battery storages and PV with the goal of end-user cost minimization. However, they assume that excess of PV cannot be injected in the grid and battery storage discharging is used only for supplying household demand. The concept of sharing PV systems in energy community under different pricing mechanisms (feed-in-tariff, net metering, as well as net purchase and sell) is analyzed through game theory in [8]. The authors in [9] compare end-consumers electricity costs in several cases: i) without any distributed technology; ii) with installed PV; iii) with battery storage installation; and iv) with both technologies integrated with the end-user. End-consumers are exposed to spot market prices, but making profit from selling surplus of PV production is not considered. A similar cost-benefit study analysis is performed in [10] based on ToU rates in North Carolina, researching feasibility of investment in PV and battery storages. The result shows that if PV capacity exceeds the load, the investment is not profitable.

The above papers do not consider characteristics of individual consumer load nor PV forecast uncertainties. They usually rely on either existing ToU tariffs, while only a few simulate dynamic prices mechanism. Furthermore, PV installations are either considered to still be within the feed-in-tariff system or cannot sell the surplus of PV generation (installed only for self-consumption).

The paper is built on the existing work and presents benefits of exposing end-consumers with installed PV and different DR programs to volatile market prices. The responsibility for net load deviations is passed on consumers, meaning they are penalized in case they do not flexibly respond in periods of inaccurate forecasts. The role of the supplier is to pass on dynamic hourly prices to the end-consumers which reflect market prices as well as penalties for any deviations. By doing this, it is possible to clearly define the value of installing specific flexible units at the end-user premises.

The analyzes are carried out for two cases: i) for a well-developed, high-liquid market in Denmark, where the suppliers already create dynamic price signals and encourage their consumers to respond to system needs. In turn this results in lower electricity cost as compared to standard pricing; ii) in a developing, low-liquid market with low volatility of market prices and a single, dominant supplier. Here, most of the electricity is traded through bilateral contracts and dominant utility company owns majority of production units. In this case the results show that exposing end-consumers to real-time market

prices, as compared to the existing two tariff system, is not profitable for them.

II. METHODOLOGY

In traditional pricing mechanism in Croatia, the end-consumer can choose between flat prices or two-tariff buying prices [11]. Consumers with a rooftop PV panel installation do not have to forecast PV production nor consumption, i.e. they are not responsible for supplier's deviation on the market and do not face any penalties. Most of PV installations are still remunerated for their production based on feed-in tariffs, however in case the PV system is not part of the scheme, the supplier in Croatia purchases the surplus of PV production from prosumer at 90% of average retail electricity price [12]. If end-consumers are not responsible for forecast deviations of the PV surplus injection in the grid due the intermittent nature of their rooftop PV production, broader integration of renewable sources on distribution level will require network reinforcement and additional flexibility in the system. On the other hand, the supplier can offer dynamic prices to end-consumer (same for buying and selling) which reflect the market prices and encourage consumers to predict their consumption and PV production by making them responsible for their deviation, as well as ensuring them lower electricity cost.

The goal of each consumer d is to minimize total cost for energy procurement, in traditional mechanism without prediction and penalties (1):

$$\min \sum_{s \in S} \pi_s \sum_{t \in T} \Delta t \cdot (\lambda_t^b \cdot P_{d,t,s}^b - \lambda_t^s \cdot P_{d,t,s}^s) \quad \#(1)$$

In market price scheme with real-time up and down regulation the cost minimization is (2):

$$\min \sum_{t \in T} \Delta t \cdot \left[\sum_{s \in S} \pi_s (\lambda_{s,t}^{UP} \cdot P_{d,s,t}^{UP} - \lambda_{s,t}^{DOWN} \cdot P_{d,s,t}^{DOWN}) + \lambda_t^{DA} \cdot P_{d,t}^{DA} \right] \quad \#(2)$$

Each consumer predicts the net load $P_{d,t}^{DA}$ for the upcoming day for hour t (positive $P_{d,t}^{DA}$ stands for buying, and negative for selling) at day-ahead stage (DA). According to the realization of scenario s , consumer needs to buy/sell more/less in real-time and faces penalties. Price for up-regulation $\lambda_{s,t}^{UP}$ is always higher than the price at DA stage (if consumer needs to buy more at real-time stage, he will pay higher price comparing to the DA price for incorrect prediction). Price for down-regulation $\lambda_{s,t}^{DOWN}$ is always lower than λ_t^{DA} (the excess of energy will be sold at lower price causing the profit loss). $P_{d,s,t}^{GRID}$ is a result of real-time net load of each consumer, and the deviation from forecasted net-load at DA stage is calculated as (3), making always just one variable (4) greater than zero in scenario s and time t :

$$P_{d,s,t}^{GRID} = P_{d,t}^{DA} + P_{d,s,t}^{UP} - P_{d,s,t}^{DOWN} \quad \#(3)$$

$$P_{d,s,t}^{UP}, P_{d,s,t}^{DOWN} \geq 0 \quad \#(4)$$

Import/ export $P_{d,s,t}^{GRID}$ from/to supplier is based on consumer's net load in scenario s and time t (5):

$$P_{d,s,t}^{GRID} + PV_{d,s,t} = P_{d,s,t}^{ms} + P_{d,s,t}^{puni\,wm} + P_{d,s,t}^{puni\,dw} + P_{d,s,t}^{puni\,dry} + P_{d,s,t}^{def} + P_{d,s,t}^{th} + P_{d,s,t}^{ch} - P_{d,s,t}^{dis} \quad \#(5)$$

Consumers under DR program supply must serve load $P_{d,s,t}^{ms}$ and flexible load (either uninterruptable appliances $P_{d,s,t}^{puni\,dry}$, $P_{d,s,t}^{puni\,wm}$, $P_{d,s,t}^{puni\,dw}$, deferrable charging of EV $P_{d,s,t}^{def}$, thermal flexible load $P_{d,s,t}^{th}$ or battery storage). The penetration of each flexible load will be studied in results.

Uninterruptable appliance (washing machine, dish washer and dryer) is started only once during the day (6):

$$\sum_{t=1}^{T-L^{ap}} x_{d,s,t}^{uni\,ap} = 1 \quad \#(6)$$

Eq. (7) ensures once cycle is started, it cannot be interrupted:

$$P_{d,s,t}^{uni\,ap} = \sum_{l=0}^{L^{ap}-1} x_{d,s,t-l}^{uni\,ap} \cdot P^{uni\,ap} \quad \#(7)$$

For deferrable load, such as electric vehicle (EV) charging, eq. (8) ensures that at the-end of charging period, the vehicle is fully charged or at the minimum level set by end-consumer:

$$\underline{E}_d \leq \sum_{t \in T} \Delta t \cdot P_{d,s,t}^{def} \leq \overline{E}_d \quad \#(8)$$

EV can be charged only from late afternoon till morning, when the car is at home. It can be charged up to maximum power of the charger (9):

$$P_{d,s,t}^{def} \leq \overline{P}_d \cdot x_{d,s,t}^{def} \quad t \leq 7, t \geq 18 \quad \#(9)$$

The battery storage system is modeled based on [13] where the charging power depends on battery's state of charge. Detail description can be found in [13].

$$SOC_{d,s,t-1} = \sum_{i=1}^4 R_i \cdot y_{d,s,t}^i \quad \#(10)$$

$$0 \leq y_{d,s,t}^i \leq 1 \quad \#(11)$$

$$\sum_{i=1}^4 y_{d,s,t}^i = 1 \quad \#(12)$$

$$y_{d,s,t}^1 \leq b_{d,s,t}^1 \quad \#(13)$$

$$y_{d,s,t}^2 \leq b_{d,s,t}^1 + b_{d,s,t}^2 \quad \#(14)$$

$$y_{d,s,t}^3 \leq b_{d,s,t}^2 + b_{d,s,t}^3 \quad \#(15)$$

$$y_{d,s,t}^4 \leq b_{d,s,t}^3 \quad \#(16)$$

$$\sum_{i=1}^3 b_{d,s,t}^i = 1 \quad \#(17)$$

$$\Delta SOC_{d,s,t} = \sum_{i=1}^4 F_i \cdot y_{d,s,t}^i \quad \#(18)$$

$$P_{d,s,t}^{ch} \leq \frac{\Delta SOC_{d,s,t}}{\eta \cdot \Delta t} \quad \#(19)$$

$$SOC_{d,s,t} = SOC_{d,s,t-1} + \eta \cdot \Delta t \cdot P_{d,s,t}^{ch} - P_{d,s,t}^{dis} \cdot \Delta t \quad \#(20)$$

$$SOC_{d,s,t} \leq \overline{SOC}_d \quad \#(21)$$

$$SOC_{d,s,0} = SOC_{d,s,24} = 0 \quad \#(22)$$

Correlations between flexible thermal load and room, floor and water temperature are presented with (23)-(25), while room temperature is bounded with minimum and

maximum temperature based on consumer's comfort requirements (26)-(27) [14]:

$$T_{d,s,t}^{room} = a_{11} \cdot T_{d,s,t-1}^{room} + a_{12} \cdot T_{d,s,t-1}^{floor} + a_{13} \cdot T_{d,s,t-1}^{water} + b_1 \cdot P_{d,s,t-1}^{th} + c_1 \cdot T_{d,s,t-1}^o \# (23)$$

$$T_{d,s,t}^{floor} = a_{21} \cdot T_{d,s,t-1}^{room} + a_{22} \cdot T_{d,s,t-1}^{floor} + a_{23} \cdot T_{d,s,t-1}^{water} + b_2 \cdot P_{d,s,t-1}^{th} + c_2 \cdot T_{d,s,t-1}^o \# (24)$$

$$T_{d,s,t}^{water} = a_{31} \cdot T_{d,s,t-1}^{room} + a_{32} \cdot T_{d,s,t-1}^{floor} + a_{33} \cdot T_{d,s,t-1}^{water} + b_3 \cdot P_{d,s,t-1}^{th} + c_3 \cdot T_{d,s,t-1}^o \# (25)$$

$$T_{d,s,t}^{room} \geq T_t^{min} \# (26)$$

$$T_{d,s,t}^{room} \leq T_t^{max} \# (27)$$

III. CASE STUDY

In traditional pricing mechanism prosumers are not obligatory to predict their net load. This role is passed on to the supplier who creates tariffs to ensure himself profit and to hedge against intermittent net load and market price volatility. With larger integration of renewable energy sources and increasing system need for flexibility, supplier creates incentives for consumers to reduce their bills through DR programs requiring their net load prediction. However, it is questionably in which cases and under which market circumstances this is feasible for both the supplier and end-consumer. The case studies demonstrate this on two countries, Croatia and Denmark, and define the value of both end-consumer flexibility units and developed retail market.

Traditional Time-of-Use prices in Croatia are shown in Table I (the reader should keep in mind that all listed prices in the paper are electricity costs only, without taxes, distribution and transmission network fee or supplier fee and other applicable costs). For Croatian prosumers ToU tariffs are currently the only available option. On the other hand, consumers in Denmark have the possibility of choosing between flat buying price or dynamic prices reflecting current market prices. As it can be seen from Fig.3., Orsted's (supply company in Denmark) buying dynamic prices [15] are higher than market prices. In addition, surplus PV production is sold at market DA price (unlike Croatia).

Bars in Fig. 1. present consumer's must serve load and lines present PV production in 5 scenarios, while Fig 2. shows outside temperature. DA Danish market prices, prices for up and down regulation in Fig. 3. are taken from Nord Pool [16]. Croatian DA prices are obtained from CROPEX [17] for 28th of October. Due to bilateral trading and lack of competitiveness in Croatia, up and down regulation are not part of the market. Up and down Croatian regulating prices are artificially simulated for the purpose of the model.

TABLE I TRADITIONAL PRICING MECHANISM IN CROATIA [12]

Low tariff (€/kW)	High tariff (€/kW)	Selling (€/kW)
0.0304	0.0620	0.0416

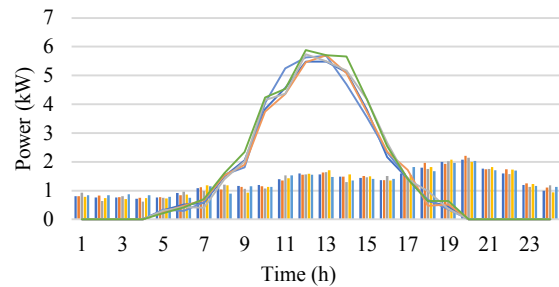

Fig. 1. Must-serve load and PV production through scenarios

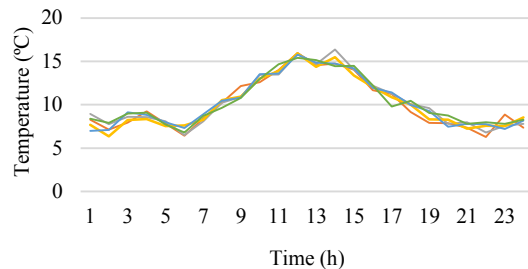

Fig. 2. Outside temperature

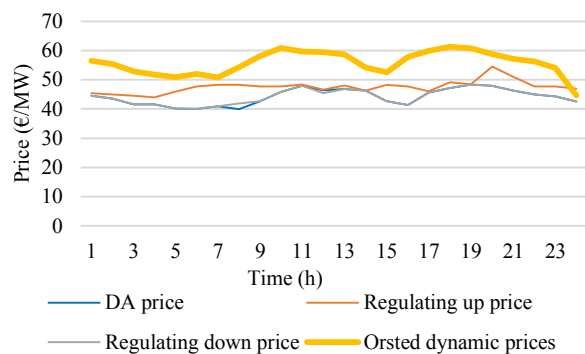

Fig. 3. DA and regulating prices at Nord Pool and Orsted dynamic prices

Consumers are equipped with a 3.7 kW EV charger. It is assumed that the EV battery (30 kWh capacity) is empty before connecting to the charger. At the end of flexible charging, according to consumer's preferences, battery's SOC is set between 25.9 kWh and 30 kWh (8). In cases 1 and 2 mentioned below, EV is being charged at maximum power 3.7 kW for 7 hours resulting in battery's SOC 25.9 kWh. To ensure the same energy consumption for flexible EV charging, the same amount is set as minimum SOC in cases 3 and 4.

Power and cycle length of uninterruptable appliances are shown in TABLE II, while consumer's comfort temperature bound in Fig. 4. Coefficients for temperature regulation are obtained from [14].

TABLE II UNINTERRUPTABLE LOAD CHARACTERISTICS [18]

Appliance ap	Power $p^{uni\ ap}$ (kW)	The length of the cycle L^{ap} (h)
Washing machine (wm)	2	3
Dryer (dry)	2.5	2
Dish washer (dw)	1.9	1

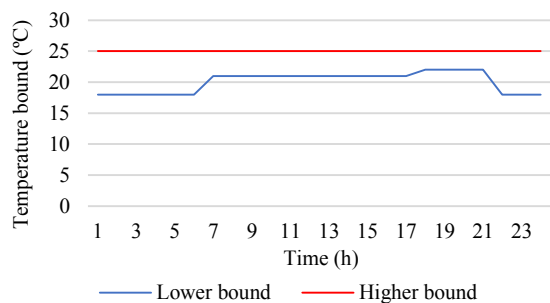

Fig. 4. Temperature bound set by end-consumer

IV. RESULTS

TABLE III compares end-consumer's cost in Croatia and Denmark with traditional pricing and market pricing. Four different DR cases are analyzed:

- 1) The consumer has PV and the only flexible load is the thermal one. This also means that the must-serve load (Fig. 1.), as well as the rest of the load has predefined behavior: the consumer turns the washing machine on at the beginning of hour 22, dryer at hour 23 and dish washer at hour 24, and charges his vehicle from hour 23 to hour 5 at the same maximum power 3.7 kW (at the end of charging period car's battery SOC is 25.9 kWh);
- 2) Same as the case 1, but the consumer in addition has also a battery storage unit of 1 kW and 1 kWh;
- 3) The consumer has PV, flexible thermal load and flexible EV charging (deferable load), while the supply of uninterruptible appliances and must-serve load is the same as in the case 1;
- 4) The consumer has PV, supplies must-serve load, flexible thermal load, flexible uninterruptible load (starting hour of washing machine, dish washer and dryer is not fixed) and flexible EV charging (flexible deferable load).

TABLE III COST IN CROATIA AND DENMARK UNDER DIFFERENT PRICING MECHANISM

Country	Pricing	Case 1 (€)	Case 2 (€)	Case 3 (€)	Case 4 (€)
Croatia	ToU	1.1219	1.0962	1.1219	1.1219
	Market	1.8062	1.8038	1.6949	1.5890
Denmark	Dynamic	2.0398	1.9091	1.5562	1.1899
	Market	1.5812	1.58119	1.5128	1.4585

A. Value of flexibility in traditional pricing

As it can be seen from TABLE III in traditional ToU pricing mechanism in Croatia, having flexible EV charging in case 3 and in addition uninterruptible flexible appliances in case 4 does not reduce end-consumer's cost. Because of the flat low price during the night, there are no savings when altering the time in which EV is charged (as

well as charging power) or shifting the operation hours of uninterruptible load.

Case 2 in Croatia shows 2.29 % of savings with integration of battery storage. Fig. 5. shows battery storage charging during the low tariff period in the first 4 hours with energy bought from the supplier or during the morning from PV excess (hours 9-10) and then discharging during the high tariff when there is insufficient PV production.

B. Value of flexibility in dynamic market pricing

In both countries there is an extra cost saving when adding a new type of DR program to end-consumer's portfolio under dynamic pricing scheme. As it can be seen from TABLE III, the consumer in Croatia in case 4 saves 12 % comparing to case 1. Consumer in Denmark can reduce the electricity bill for almost 8 % when adding new programs of DR. As it can be seen when comparing results in Fig. 6. and 7., for case 4 in Denmark with more flexible options participate in DR program under market prices, net load drastically changed during the valley prices at the beginning of the day. All uninterruptible appliances are switched on during those hours, ensuring big cost reduction comparing to the case 1 when consumers turn them on before going to bed.

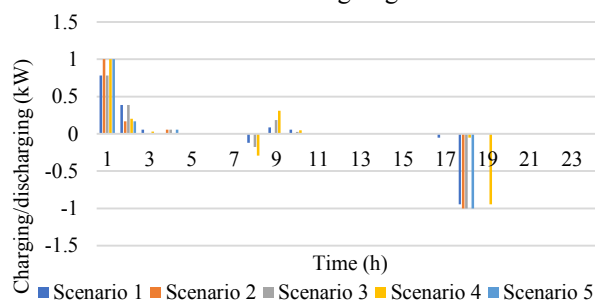

Fig.5 Battery charging and discharging in Croatian ToU pricing

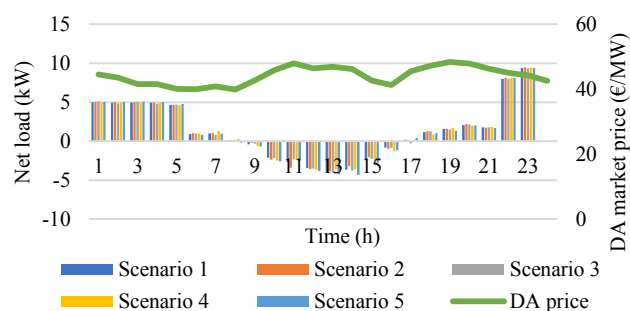

Fig. 6. Net load in case 1

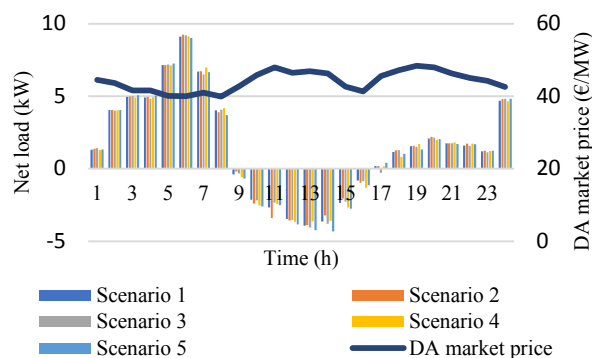

Fig. 7 Net load in case 4

C. The impact of market liquidity on end-consumers

In high-liquid markets with many bids and offers, as one analyzed here in Denmark, competitiveness determines the market price ensuring consumers lower electricity cost when exposed directly to the market prices. On the other hand, the majority of energy in Croatia is traded through bilateral contracts resulting in low-liquid market with very high market prices (even higher than supplier's prices on instances). The end-consumer's cost increases significantly if consumer is exposed to CROPEX market prices. Furthermore, there is no balancing market in Croatia and Transmission System Operator is responsible for ensuring security of power system by procuring balancing services through bilateral contracts with the only utility company capable of providing auxiliary services.

V. CONCLUSION

To encourage broader integration of RES in the line with low-carbon policies, supplier (or aggregator) offers dynamic prices to end-consumers reflecting market prices. To enable dynamic prices, supplier must protect itself against consumers' volatile behavior and hedges this risk by making them responsible for deviation from predefined DA schedule.

The results show the benefits of different flexibility options under dynamic prices comparing to the traditional pricing. A significant cost reduction occurs with higher penetration of flexible appliances comparing to ToU pricing where the flat prices do not fully exploit the flexibility of DR.

Developing and developed markets exhibit different market prices at power exchanges. The results indicate the need for forming complete power market in Croatia to encourage competition and reduce market prices. Additionally, competition on retail level results in lower prices for end-consumers, penalizing the passive ones and creating opportunities for investing in flexible units and responding to system needs.

REFERENCES

- [1] G. He, Q. Chen, C. Kang, Q. Xia, K. Poolla, "Cooperation of wind power and battery storage to provide frequency regulation in power markets," *IEEE TRANSACTIONS ON POWER SYSTEMS*, vol. 32, no. 5, September 2017, pp.3559-3568
- [2] X. Dui, G. Zhu, L. Yao, "Two-stage optimization of battery energy storage capacity to decrease wind power curtailment in grid-connected wind farms," *IEEE TRANSACTIONS ON POWER SYSTEMS*, vol. 33, no. 3, May 2018, pp. 3296-3305
- [3] Y. A. Katsigiannis, E. S. Karapidakis, "Operation of wind-battery hybrid power stations in autonomous Greek islands," *52nd International Universities Power Engineering Conference (UPEC)*, 28.-31. August 2017, Heraklion, Greece
- [4] N. Zhihao, W. Can, Z. Bin, Z. Keren, Z. Jian, X. Yonghai, Z. Guandong, R. Bin, "Research on application of battery energy storage system based on MMC in wind power integration," *2017 IEEE Conference on Energy Internet and Energy System Integration (EI2)*, 26.-28. November 2017, Beijing, China
- [5] L. Zhou, Y. Zhang, X. Lin, C. Li, Z. Cai, P. Yang, "Optimal sizing of PV and BESS for a smart household considering different price mechanisms," *IEEE Access*, vol: 6, June 2018, pp. 41050 – 41059
- [6] H. Sadeghian, Z. Wang, "Decentralized demand side management with rooftop PV in residential distribution network," *2018 IEEE Power & Energy Society Innovative Smart Grid Technologies Conference (ISGT)*, 19-22 February 2018, Washington, DC, USA
- [7] F. Hafiz, D. Lubkeman, I. Husain, P. Fajri, "Energy storage management strategy based on dynamic programming and optimal sizing of PV panel-storage capacity for a residential system," *2018 IEEE/PES Transmission and Distribution Conference and Exposition (T&D)*, 16-19 April 2018, Denver, CO, USA
- [8] P. Chakraborty, E. Baeyens, P. P. Khargonekar, K. Poolla, P. Varaiya, "Analysis of solar energy aggregation under various billing mechanisms," *IEEE Transactions on Smart Grid*, June 2018
- [9] A. L. Shah, A. T. Awami, "Financial Benefits by Installing PV Generation and Energy Storage Systems for Households," *2017 Saudi Arabia Smart Grid (SASG)*, 12-14 Dec. 2017, Jeddah, Saudi Arabia
- [10] X. Zhu, G. Henri, J. Yan, N. Lu, "A cost-benefit study of sizing residential PV and ES systems based on synthesized load profiles," *2017 IEEE Power & Energy Society General Meeting*, 16-20 July 2017, Chicago, IL, USA
- [11] HEP Opskrba, Energy supplier in Croatia, prices available online: <https://mojracun.hep.hr/hepi/v2/index.html#!/izracun>
- [12] Law on Renewable Energy Sources and Highly Effective Cogeneration in Croatia, available online: https://narodne-novine.nn.hr/clanci/sluzbeni/2015_09_100_1937.html
- [13] H. Pandžić, V. Bobanac, "An Accurate Charging Model of Battery Energy Storage," *IEEE Transactions on Power Systems*, October 2018
- [14] M. Zugno, J. M. Morales, P. Pinson, H. Madsen, "A bilevel model for electricity retailers' participation in a demand response market environment," *Energy Economics*, vol. 36, March 2013, pp. 182-197
- [15] <https://orsted.dk>
- [16] <https://www.nordpoolgroup.com>
- [17] <https://www.cropex.hr/hr/>
- [18] <https://www.gorenje.hr/proizvodi>

A review of practical aspects of existing TSO-DSO coordination mechanisms in Europe and proposal of an innovative hybrid model in ATTEST project

Mirna Gržanić

University of Zagreb
Faculty of Electrical Engineering
Zagreb, Croatia
mirna.grzanic@fer.hr

Tomislav Capuder

University of Zagreb
Faculty of Electrical Engineering
Zagreb, Croatia
tomislav.capuder@fer.hr

Martin Bolfek

HEP - Operator distribucijskog sustava d.o.o.
Elektra Koprivnica
Koprivnica, Croatia
martin.bolfek@hep.hr

Florin Capitanescu

Luxembourg Institute of Science and Technology
Luxembourg, Luxembourg
florin.capitanescu@list.lu

Abstract—The transition towards a carbon-neutral power system puts the focus on unlocking local flexibility potential. Providing ancillary services (AS) on the local level arises as a new option in power system operation and control due to the increasing growth of distributed energy sources (DERs). To facilitate the possibility of distribution level users to provide system-wise services, system operators need to coordinate their actions and operational plans. To avoid the activation of counteracting service, the coordination between the Transmission System Operator (TSO) and the Distribution System Operator (DSO) is required in multiple time horizons, from a day or week ahead to real-time. The paper reviews several approaches in TSO-DSO coordination in different market environments pointing out the main features, advantages, and drawbacks of each coordination scheme. Unlike previously investigated coordination schemes, the paper proposes a novel coordination mechanism which is being developed in ATTEST project. The coordination is divided into day-ahead (DA) and real-time (RT) stages and describes the sequence of each system operator's action in the AS reservation and activation procedure.

Index Terms—Ancillary services, Distribution System Operator, Local markets, Transmission System Operator

I. INTRODUCTION

The European Union strives to be the pioneer in the clean energy transition towards carbon-neutrality in 2050. According to [1], the recently set goals focus on reducing greenhouse gas emission by at least 55% by 2030 compared to 1990. Moreover, the increase in the production from renewable energy sources and in energy efficiency will lead to a more efficient and secure energy supply with improved environmental benefits, reduced dependence on energy import, and affordable energy for all final users. In order to tackle the issues arisen from the broad integration of renewable energy sources (RES), innovative approaches in power

system planning and operation are necessary to ensure secure and reliable management of transmission and distribution networks. Traditionally, distribution networks are planned according to the 'Fit-and-forget' (FiT) approach, deciding on the investments based on the worst-case operational scenario.

Investments in new assets are not always the best options because these worst-case scenarios do not occur frequently. For the optimal use of the existing infrastructure, it is necessary to flexibly manage the network assets and incentivize the flexible behavior of the final consumer. This entails creating adequate price signals and ancillary services (AS) in different time frameworks (monthly, daily, and in real-time) that encourage changes in energy production, consumption and storage. The utilization of these services implies the changes not only in the planning stage, but also in the operation which requires the creation of different tools for system planning and flexibility activation.

To ensure secure and reliable network operation together in a low-carbon environment, Active Distribution Network Management (ADNM) is being introduced for control and operation of distribution network in real-time [2]. Unlike network reinforcement used in FiT, ADNM is focused on modern technologies (battery storages, smart meters) and innovative approaches (dynamic pricing, provision of AS from a wide range of demand response programs). Diverse resources connected to the distribution network (distributed generators, electric vehicles, energy storage, flexible household appliances) can provide multiple services to the system in order to postpone or avoid network reinforcement.

The transition towards carbon-neutrality enhances the active participation in AS provision from diverse distributed energy resources (DERs) to solve local network problems, but also on the transmission level. In order to ensure that flexibility activation from DERs by the TSO is harmonized with the DSO's requirements, it is essential to set up a coordination framework between the Transmission System Operator (TSO) and the Distribution System Operator (DSO). Two main structures in the market organization of the TSO/DSO

This research work has received funding from the European Union's Horizon 2020 research and innovation program under grant agreement No 864298 (project ATTEST) and in part from the Croatian Science Foundation (HRZZ) and Croatian Distribution System Operator (HEP ODS) under the project IMAGINE — Innovative Modelling and Laboratory Tested Solutions for Next Generation of Distribution Networks.

coordination are distinguished. In the centralized structure, all flexibility providers offer their services in one central market. On the other hand, decentralized structure recognizes local and global markets. The paper reviews 5 substructures of a market organization that can provide a coordination framework for system operators.

The paper highlights the following contribution divided in two parts:

- A review of TSO-DSO coordination mechanisms in European projects with a focus on benefits and obstacles in implementation,
- The proposal of an innovative coordination mechanism in ATTEST project divided in DA and RT steps with detailed explanation of each step for both TSO and DSO.

II. REGULATORY BARRIERS

The transition towards a carbon-neutral power system opens the door for market participation for all players. However, some regulatory barriers still inhibit the participation of DERs in AS market. Today, the DSO does not contract flexibility services in the market to solve local congestion or voltage deviations. In the DSO cost structure, AS procurement is not refunded because it is not considered as an operational expense. In order to increase the market liquidity, transparency, and flexibility options, it is important to remove these barriers. According to the [3], the European Union suggests a proposal of a new regulatory framework in each Member State to allow and provide incentives to DSOs to procure flexibility services in their operating area to improve efficiencies in the operation and development of the distribution system. The procurement of AS should be done in a non-discriminatory, transparent, and market-based procedure. The value of energy efficiency, as well as the potential of utilizing services from demand response, energy storage facilities, or other resources, needs to be included in the network development plans. DSOs shall be adequately remunerated for the procurement of such services to allow them to recover at least their reasonable corresponding costs, including the necessary information and communication technology expenses and infrastructure costs. The rules for aggregation, market product definition, and market mechanisms must be established and clearly defined [4]. However, the DSO cannot participate in the market as both the service provider and the MO at the same time (the DSOs cannot buy or sell the service provided by them) [5]. System operators are not allowed to own or operate energy storage units because energy storage units should be competitive and market-based. Moreover, system operators are regulated entities. This requires their market neutrality. Owning energy storage would result in specific market power, especially in AS markets with low liquidity.

However, the energy storage unit as a fully integrated network component is essential for the system operator to ensure reliable and secure network operation. Moreover, a special case in which the regulatory authority may allow the DSO to own the storage unit must fulfill several conditions:

- other entities in transparent and non-discriminatory tendering procedures have not been awarded a right to own, develop, manage or operate energy storage or other possible flexibility providers,

- or could not deliver these services at a reasonable cost and in a timely manner.

III. COORDINATION BETWEEN SYSTEM OPERATORS

The information exchange and coordination between TSO and DSO are necessary to ensure the optimal utilization of resources, secure and efficient system operation and to facilitate market development. The coordination must ensure that actions taken from one system operator do not have a negative impact on either distribution and transmission network. In order to ensure the cost-efficient, secure and reliable development and operation of transmission and distribution networks, all relevant system users have to be included in all stages, from planning (long-term planning of network investments) to operation (the performance of generation assets and demand response).

The establishment of joint TSO-DSO optimization for AS procurement is crucial in order to minimize the total cost for both the TSO and the DSO. The coordination should consider the investment in the new units or network reinforcement and flexibility service provision from resources connected to transmission and distribution network. It is also important to extend the role of the DSO from the system operator to an entity who acts on the behalf of the TSO to support the implementation of the local AS markets. Moreover, the regulation has to be extended in order to emphasize the importance of respecting DGs constraints in AS provision.

TSO-DSO coordination mechanisms have already been investigated in several projects (SmartNet [6]–[8], CoordiNet [9], TDX assist [10], [11]) and further examined in ATTEST [12]. The coordination mechanisms are grouped in 5 categories:

- Centralized AS market model,
- Local AS market model,
- Shared balancing responsibility model,
- Common TSO-DSO AS market model,
- Integrated flexibility market model.

Roles of market participants in grid operation, procurement, activation and settlement are shown in Table I for each group of coordination mechanisms.

A. Centralized AS market model

In this group of TSO / DSO coordination scheme the TSO is the only buyer of AS from resources connected to the transmission and distribution grid. The DSO cannot procure flexibility services to solve local problems. The DSO is responsible for the product prequalification to ensure that DERs can provide specific service which they bid for.

This coordination scheme is very similar to the already existing AS market organization, although it includes flexibility offers from DERs. This approach is the closest to adoption due to the lowest number of regulatory issues. This market approach is characterized with only one high liquid market which makes it simple for operation with clearly defined market products.

However, if the TSO organizes the system prequalification to meet the distribution network constraints, the DSO needs to provide necessary data to the TSO. This can increase a computational complexity due to additional constraints

TABLE I
MAIN ACTORS IN DIFFERENT COORDINATION SCHEMES

Role	Centralized AS market model	Local AS market model	Shared balancing responsibility model	Common TSO-DSO AS market model	Integrated flexibility market model
System Operator	TSO (TG) DSO (DG)	TSO (TG) DSO (DG)	TSO (TG) DSO (DG)	TSO (TG) DSO (DG)	TSO (TG) DSO (DG)
System Balance Responsible	TSO (TG; DG)	TSO (TG; DG)	TSO (TG) DSO (DG)	TSO (TG; DG)	TSO (TG; DG)
Data Manager	TSO (TG) DSO (DG)	TSO (TG) DSO (DG)	TSO (TG) DSO (DG)	TSO (TG) DSO (DG)	TSO (TG) DSO (DG) IMO
Reserve Allocator	TSO (TG; DG)	TSO (TG) DSO (DG)	TSO (TG) DSO (DG)	TSO (TG) DSO (DG)	TSO (TG) DSO (DG)
Buyer	TSO (TG; DG)	TSO (TG; DG) DSO (DG)	TSO (TG) DSO (DG)	TSO (TG; DG) DSO (DG)	TSO (TG; DG) DSO (DG) CMP (TG; DG)
Seller	CMP (TG; DG)	CMP (TG; DG)	CMP (TG; DG)	CMP (TG; DG)	TSO (TG; DG) DSO (DG) CMP (TG; DG)
Market Operator	TSO (TG; DG)	TSO (TG) DSO (DG)	TSO (TG) DSO (DG)	TSO (TG; DG) DSO (TG; DG)	IMO (TG; DG)
Aggregation	CMP (TG; DG)	CMP (TG; DG) DSO (DG)	CMP (TG; DG)	CMP (TG; DG) DSO (DG)	CMP (TG; DG)
Flexibility Dispatcher	TSO (TG; DG) CMP (TG; DG)	TSO (TG; DG) DSO (DG) CMP (TG; DG)	TSO (TG) DSO (DG) CMP (TG; DG)	TSO (TG; DG) DSO (DG) CMP (TG; DG)	IMO and TSO (TG; DG) DSO (DG) CMP (TG; DG)
Metered Data Responsible	TSO (TG) DSO (DG) CMP (TG; DG)	TSO (TG) DSO (DG) CMP (TG; DG)	TSO (TG) DSO (DG) CMP (TG; DG)	TSO (TG) DSO (DG) CMP (TG; DG)	TSO (TG) DSO (DG) CMP (TG; DG)

CMP - Commercial Market Player, IMO - Independent Market Operator, MO - Market Operator, DG - Distribution Grid, TG - Transmission Grid

from distribution network. When it comes to data exchange, only limited information flow between system operators is required because the DSO is not involved in the procurement of AS which can violate the distribution network constraints if not included in the system prequalification.

Several versions of the centralized model are proposed in the literature review: Total TSO model [13], Market DSO model C1 and C2 [13], Full integration market model [14], Enhanced Bulk Balancing Authority Model variants A and B [15], Regional Reserve Market Plus [16].

B. Local AS market model

The DSO has the priority in procuring AS from the resources connected to the distribution network. Unlike in Centralized approach where the role of the DSO is very limited, in this approach the DSO is in charge of a local market clearing. After the local market clearing, the remaining aggregated flexibility at the distribution level can be offered to the TSO who is in charge of the central market clearing.

This coordination approach is not in the line with the current market regulation. It also implies additional investment in communication technology to ensure data exchange in real-time in order to avoid the procurement of flexibility services in opposite directions from DSO and TSO. The potential problem might also be several local markets with low capability of aggregation resulting in low market liquidity. If the DSO operates small area, generation or load curtailment might occur due to limited number of flexibility providers. Diverse local markets can have different local market products which needs to be harmonized. To overcome this issue, it is possible to aggregate all local markets in order to increase the liquidity of the central market.

Several modifications of described coordination scheme are given in the literature: Cascade model [16], Separated

TSO and DSO congestion management [17], Multi-level market model [9], Coordination mechanism between local and national market [10].

C. Shared balancing responsibility model

The roles of the DSO and the TSO are completely separated. The definition of roles is clear: the DSO monitors and controls the actions in distribution networks and their responsibility is expanded on balancing services in distribution network. DERs can be contracted and activated only by the DSO, while the TSO is in charge of management and balancing in the transmission network. Due to extended role of the DSO, the increased number of local flexibility resources is required. If the operation of the DSO is limited on a small area, local markets can have low liquidity and limited sources of flexibility which will increase the price of ancillary service or cause load shedding or RES curtailment. This type of coordination can be a threat to global stability if the DSO fails in local balancing. The TSO will face lower cost due to reduced balancing responsibility. From computational point of view, this approach is not complex to solve due to separated optimization process for each system operator.

Already elaborated coordination mechanisms related to this group can be found in: Fragmented market model [9], System Balancing Cost Allocation based on the Cost-Causality Principle, Market DSO model C1 and C2 [13], Total DSO model [13], DSO procuring the flexibility services and providing the load/generation forecast at primary substation [11].

D. Common TSO-DSO AS market model

This scheme is the most complex coordination between the TSO and the DSO. It requires a high level of coordination between system operators which results in the most efficient

allocation of resources. System operators jointly operate the common market in which resources connected to transmission and distribution network compete. Usually, the TSO is responsible for the balancing, but both TSO and DSO have the same priority in procuring AS from DERs. The market is cleared considering distribution and transmission network constraints.

This scheme requires the investment in additional communication infrastructure. The cost division between system operators is complex due to joint market operation and service procurement.

The details of this scheme can be found in several models: Hybrid model [15], Combined TSO and DSO congestion management with separated balancing [17], Combined balancing and congestion management for all system operators together [17], Single Flexibility Market Place [18], New flexibility platform [16].

E. Integrated flexibility market model

In the integrated approach, both regulated and deregulated market participants have access to the central market. This results in direct competition between market players. To ensure the market neutrality, the third party is in charge of the market operation. This type of market model has high liquidity due to high number of participants and competitive bids. The main difference between this and other coordination mechanism is that system operators can resell AS which they do not need.

The main problem in this approach is a high competition for the same resource which can increase the price of the service (different entities can compete for the service, not only system operators). The TSO might need to procure additional services outside the market in order to ensure secure network operation resulting in decreased market liquidity. The computation effort is high because the model considers both transmission and distribution network constraints.

Several examples are listed: Integrated Market Model [9], Distributed market models [9], Regional Intraday Plus market [16], Sequential Design, TSO-DSO Mechanism, and TSO-DSO-Retailer Mechanism [19].

IV. CONCEPTS OF TSO-DSO AS MARKET

The provision of AS is divided in the process of service prequalification, procurement, activation and settlement. The focus in this section is put on providing the following AS from DERs: frequency control, congestion management and voltage control. As one can notice in Table II, not all AS can be provided in each coordination scheme [6] :

Congestion management is used in each coordination scheme. As the TSO is the only buyer of AS in the Centralized model and the TSO cannot control the voltage at the TSO-DSO connecting point, voltage control is not applicable on the distribution level. Due to very specific characteristics of voltage and frequency control, Integrated flexibility market model is not relevant for these service procurement. As the TSO is the only one responsible for the frequency control and the DSO does not buy services for the frequency control, Local AS market model, Shared balancing Responsibility and Integrated flexibility market model would not be used

TABLE II
FEASIBILITY OF SERVICE PROVISION IN DIFFERENT COORDINATION MECHANISMS

Flexibility service	Congestion management	Frequency control	Voltage control
Centralized AS market model	+	+	-
Local AS market model	+	-	+
Shared balancing responsibility model	+	-	+
Common TSO-DSO AS market model	+	+	+
Integrated flexibility market model	+	-	-

for provision of frequency control because the TSO is not directly involved in the market operation.

The coordination between system operators is still restricted with several regulatory barriers. No process for prequalification or active blocking of bids by DSOs is defined by law. The regulated cost structure of the DSO does not consider flexibility procurement as an operational expense and thus it is not remunerated. This poses a problem to Local, Shared balancing responsibility and Integrated flexibility market model in which the DSO purchases flexibility to solve local problems. The regulation does not allow the DSO to aggregate the local flexibility bids and to offer them to the TSO. This has to be redefined because flexibility offers not used locally in Local AS market model might be wasted. Commercial market players are not allowed to buy AS in the market. Moreover, system operators are not allowed to resell previously contracted flexibility. To implement Integrated flexibility market model, these restrictions have to be removed. When it comes to balancing responsibility, nowadays the TSO is the only entity responsible for system balance, while in the Shared balancing responsibility model the DSO is responsible for balancing on the distribution level [20]. To overcome mentioned barriers, the paper proposes a novel coordination mechanism developed in ATTEST project which is described in the following chapter.

V. ATTEST TSO / DSO COORDINATION APPROACH

This section is focused on the coordination mechanism developed in the project ATTEST [21]. Diverse tools for transmission and distribution network planning and operation which are being developed in the project will interact based on the proposed coordination. None of the previously described coordination approaches does not distinguish DA reservation and RT activation in the process of AS procurement. The main novelty of ATTEST TSO/DSO coordination is a proposal of a two-stage AS procurement divided in DA and RT operation. The existing coordination approaches did not explain the separation/aggregation of active and reactive power bids. ATTEST TSO/DSO coordination precisely defines that the provision of the service related to active and reactive power is part of one tool executed in two steps due to decoupling of active and reactive bids. DA AS market is cleared after the closure of the DA energy market. The result of the DA energy market is taken into account when TSO and DSO agree on DA active power P^{DA} and corresponding reactive power Q^{DA} exchange at their interface. Due to

complexity of pricing mechanism for the coupled P-Q bid for AS, bids for active and reactive power are decoupled and independently submitted to the DSO with the constant cost per offered unit of energy. The description of active power AS reservation in DA operation is described in 4 steps as shown in Fig. 1:

- 1) DERs submit their active power bids (P^{bid}) to the DSO. P^{bid} is divided in up bids (P^{up}) and down bids (P^{down}) with the corresponding cost.
- 2)a) The DSO runs the AC Optimal Power Flow (AC OPF) [22] and, as the result, obtains the active power flow range and the cost at TSO-DSO interface given ensuring the DSO network constraints are met.
 - b) The DSO submits active power flow range to global P market run by TSO in the form of $[P^{DA-}, P^{DA+}]$.
- 3)a) The TSO runs the AC Security Constrained Optimal Power Flow (AC SCOPF) [23] to define the range of required flexibility (from providers connected to the transmission level and from TSO-DSO flexibility range defined in the previous step).
 - b) The TSO sends to the DSO cleared bids for up (P^{up*}) and down (P^{down*}) reserved capacity of AS. The optimal active power flow at the TSO-DSO interface is defined as the range $[P^{DA-}, P^{DA+}]$. If in real-time the TSO will not activate the services from DERs, the active power flow at the TSO-DSO interface will be equal to DA energy schedule P^{DA} .
- 4)a) DSO clears the local market in order to optimize distribution network operation with the respect of agreed P^{up*} and P^{down*} .
 - b) DSO sends the request for active power capacity reservation (P^{res_ca}) to DERs (from both global and local market).

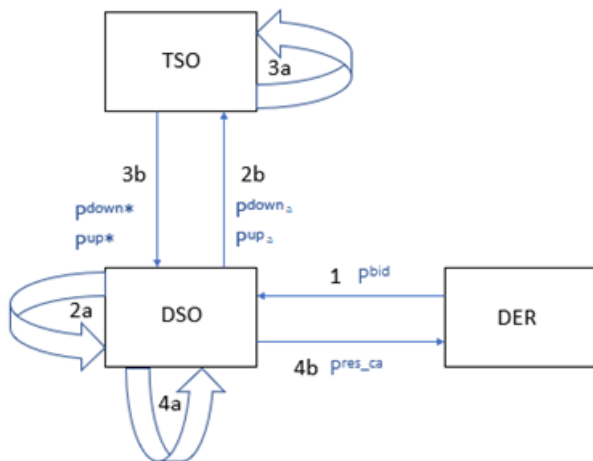

Fig. 1. Reservation of active power services at DA operation planning

The reservation of reactive power capacity for provision of AS in DA operation is described in 4 steps as shown in Fig. 2:

- 5) DERs submit their reactive bids (Q^{bid}) to the DSO. Q^{bid} is divided in up bids (Q^{up}) and down bids (Q^{down}) with corresponding cost.
- 6)a) The DSO calculates via AC OPF the Q flow range and cost at TSO-DSO interface with fixed $[P^{DA-}, P^{down*}, P^{DA+}, P^{up*}]$ values provided by the TSO such that the DSO network constraints are met.
 - b) The DSO submits Q flow range bids capability to global Q market run by TSO.
- 7)a) The TSO determines the required flexibility to satisfy voltage constraints through AC SCOPF including Q flow ranges provides by DSO.
 - b) The TSO sends to the DSO cleared bids for up Q^{up*} and down Q^{down*} regulation. The optimal reactive power flow at TSO-DSO interface can be in range $[Q^{DA-}, Q^{DA+}]$. If the TSO does not require any service from DERs, the active power flow at the TSO-DSO interface will be equal to day-ahead energy schedule Q^{DA} .
- 8)a) DSO clears the local market in order to solve local problems with the respect of agreed Q^{up*} , Q^{down*} , P^{up*} , P^{down*} .
 - b) DSO sends the request for active power capacity reservation (Q^{res_ca}) to DERs (from both global and local market).

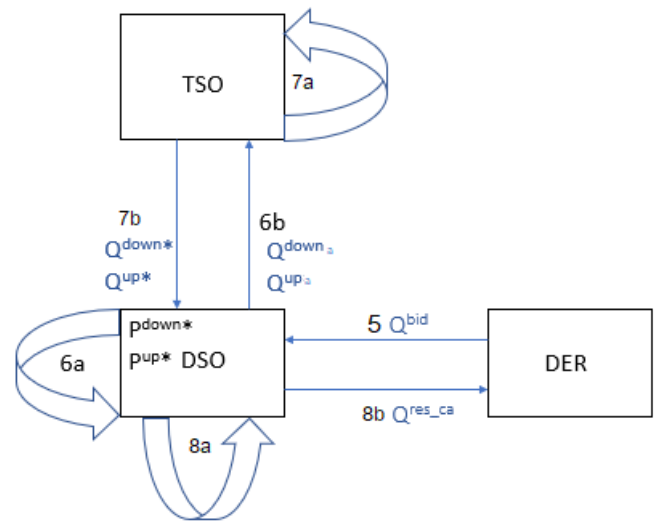

Fig. 2. Reservation of reactive power services at DA operation planning

In real-time operation the reserved services on a DA horizon can be activated in case of predicted contingencies. The proposal of the ATTEST coordination scheme is as follows in Fig. 3:

- 9) The TSO runs the SCOPF in RT and determines the required AS P^{**} and Q^{**} . Frequency security constraints will be integrated in the SCOPF formulation in a newly developed ATTEST tool for on-line dynamic security assessment.
- 10) The TSO sends to the DSO the desired active power P^{**} and reactive power Q^{**} .
- 11) The DSO runs RT OPF with the fixed P^{**} and Q^{**} values at the TSO/DSO interface and clears the local RT market making sure to satisfy DG constraints.

12) The DSO sends signals to activate the flexibility providers / DERs.

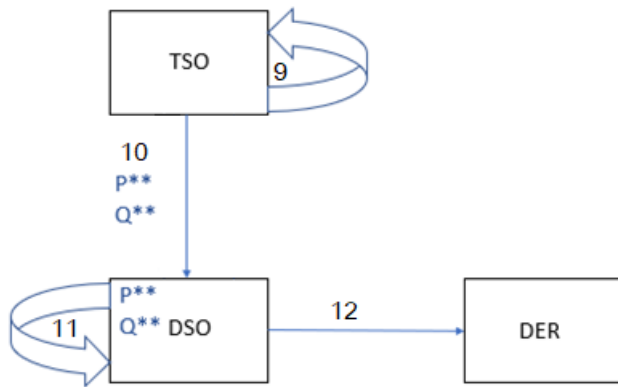

Fig. 3. Activation of active and reactive power services in real-time operation

VI. DISCUSSION AND CONCLUSION

The paper provides insights into the state-of-the-art mechanisms on TSO/DSO coordination for procurement and activation of AS. The existing research groups these mechanisms into 5 main categories based on the priority in the AS reservation and the sequence of activation. The paper develops a hybrid model within the ATTEST project by optimizing the benefits of Centralized, Local and Shared balancing responsibility market model and trying to avoid the downsides which would hinder the development of supporting operational and planning models. In ATTEST TSO / DSO coordination approach the TSO has the priority in AS reservation. Provided that the DSO can satisfy operation constraints with remaining flexibility, the DSO is responsible for solving local congestion management and voltage deviations. In order to solve these issues, the DSO can procure AS from DERs. The role of the DSO is extended to ensure that reserved capacity of AS in DA market provided by DERs is delivered to the TSO in the RT. Besides the DSO needs to meet operation constraints in MV and LV network, the DSO also respects an agreed AS schedule with the TSO due to the shared local flexibility. When it comes to cost optimal solutions, the model derived in this paper is sub-optimal for the DSO and does not distribute costs between system operators. The extra cost incurred by the DSO should be remunerated to some extent by the TSO. The efficiency and secure operation of distribution grid in RT is ensured because distribution network constraints are considered in the market clearing approach. The communication and coordination is very precise, but this implies some heavy calculation challenges in sharing data due to short time frame.

Due to different regulatory frameworks and operation policy in European countries, TSO-DSO coordination mechanisms are still under developing. The paper described existing coordination mechanisms and proposed a novel approach divided in DA reservation and RT activation of ancillary services which will increase provision of flexibility service

from DERs and foster the transition towards carbon-neutral power system.

REFERENCES

- [1] "State of the Union: Commission raises climate ambition and proposes 55% cut in emissions by 2030," 2020. [Online]. Available: https://ec.europa.eu/commission/presscorner/detail/en/IP_20_1599
- [2] Eurelectric, "Active distribution system management: a key tool for the smooth integration of distributed generation," *Eurelectric*, no. February, pp. 1–53, 2013.
- [3] "Directive (EU) 2019/944 of the European parliament and of the council of 5 June 2019 on common rules for the internal market for electricity and amending Directive 2012/27/EU." [Online]. Available: <https://eur-lex.europa.eu/legal-content/EN/TXT/PDF/?uri=CELEX:32019L0944&from=EN>
- [4] "CoordinET Deliverable 1.1 – Market and regulatory analysis : Analysis of current market and regulatory framework in the involved areas." [Online]. Available: <https://www.iit.comillas.edu/docs/IIT-19-051I.pdf>
- [5] ENTSO-E, "Towards smarter grids : Developing TSO and DSO roles and interactions for the benefit of consumers," pp. 1–8, 2015. [Online]. Available: https://eepublicdownloads.entsoe.eu/clean-documents/Publications/Position papers and reports/150303_ENTSO-E_Position_Paper_TSO-DSO_interaction.pdf
- [6] G. Migliavacca, M. Rossi, D. Six, and et al., "SmartNet: H2020 project analysing TSO-DSO interaction to enable ancillary services provision from distribution networks," *CIREN - Open Access Proceedings Journal*, vol. 2017, no. 1, pp. 1998–2002, 2017.
- [7] H. Gerard, E. Vito Rivero, and D. Six, "SmartNet Deliverable D1.3: Basic schemes for TSO-DSO coordination and ancillary services provision," no. 691405, 2020.
- [8] G. Leclercq, M. Pavesi, T. Gueuning, and et al., "SmartNet Deliverable D2.2: Network and market models," no. 691405, pp. 1–201, 2019. [Online]. Available: <http://smartnet-project.eu/publications>
- [9] A. Delnooz, J. Vanschoenwinkel, E. Rivero, and et al., "CoordinET Deliverable D1.3: Definition of scenarios and products for the demonstration campaigns," pp. 1–93, 2019. [Online]. Available: https://private.coordinet-project.eu/files/documentos/5d72415ced279Coordinet_Deliverable_1.3.pdf
- [10] "TDX-ASSIST Deliverable 1.1: State of the Art - TSO-DSO Interoperability," no. December 2017, pp. 1–146, 2020.
- [11] M. Radi, "TDX-ASSIST Deliverable D3.2: Use Case Definitions," Tech. Rep. 2018, 2020.
- [12] "ATTEST — Home." [Online]. Available: <https://attest-project.eu/>
- [13] L. Kristov, P. De Martini, and J. D. Taft, "A Tale of Two Visions: Designing a Decentralized Transactive Electric System," *IEEE Power and Energy Magazine*, vol. 14, no. 3, pp. 63–69, 2016.
- [14] P. M. Platform, "www.econstor.eu," 2017.
- [15] S. P. Burger, J. D. Jenkins, C. Batlle, and et al., "Restructuring Revisited: Competition and Coordination in Electricity Distribution Systems," Tech. Rep. March, 2018. [Online]. Available: <http://ceep.mit.edu/files/papers/2018-007.pdf>
- [16] Agora Energiewende, "Smart-Market-Design in deutschen Verteilnetzen," *Studie im Auftrag von Agora Energiewende*, p. 156, 2017. [Online]. Available: https://www.agora-energiewende.de/fileadmin2/Projekte/2016/Smart_Markets/Agora_Smart-Market-Design_WEB.pdf
- [17] ENTSO-E, "TSO-DSO report: An Integrated Approach to Active System Management," Tech. Rep. 1, 2019.
- [18] ENTSO-E, "Distributed flexibility and the value of TSO/DSO coordination," pp. 1–7, 2016. [Online]. Available: https://www.entsoe.eu/Documents/Publications/Position papers and reports/entsoe_pp_DF_1712_web.pdf?Web=1
- [19] A. Vicente-Pastor, J. Nieto-Martin, D. W. Bunn, and et al., "Evaluation of flexibility markets for retailer-dso-tso coordination," *IEEE Transactions on Power Systems*, vol. 34, no. 3, pp. 2003–2012, 2019.
- [20] K. Oureilidis, K. N. Malamaki, K. Gallos, and et al., "Ancillary services market design in distribution networks: Review and identification of barriers," *Energies*, vol. 13, no. 4, 2020.
- [21] "ATTEST — Home." [Online]. Available: <https://attest-project.eu/>
- [22] F. Capitanescu, "Tso-dso interaction: Active distribution network power chart for tso ancillary services provision," *Electric Power Systems Research*, vol. 163, pp. 226–230, 2018.
- [23] F. Capitanescu, M. Glavic, D. Ernst, and L. Wehenkel, "Applications of security-constrained optimal power flows," in *MEPS, Wroclaw*, 09 2006.

Biography

Mirna Gržanić is a researcher at Department of Energy and Power Systems at Faculty of Electrical Engineering and Computing, University of Zagreb. She received her bachelor's and master's degree in electrical engineering and communication technology in July 2014 and September 2016 of the same Faculty, respectively.

Her research interests cover the transition towards sustainable power system from the perspective of the final user together with the integration of low-carbon technology at their premises. Her research activities focus on the development of innovative pricing models which stimulate the flexible behaviour of the final user according to the needs in the power system. She has been involved in several scientific projects funded by Croatian Science Foundation and European Commission.

Mirna is involved in teaching activities as a teaching assistant in Bachelor Programme course Electric Power Engineering, initiated and holds lessons in the seminar Introduction in optimization and supervises bachelor and master student thesis progress.

She spent four months (2018) on specialization at University of Malaga, Spain and five months (2019) in European Commission, Joint Research Centre Ispra, Italy. She has published several conference and scientific journal papers and worked on technical studies for the national electrical power utility.

Mirna is a member of professional associations IEEE, CIGRE, INFORMS, PES, and IEEE Women in Engineering.

Journal Papers

- [J₁]M. Gržanić, J. M. Morales, S. Pineda, and T. Capuder, "Electricity cost-sharing in energy communities under dynamic pricing and uncertainty, " *IEEE ACCESS*, pp. 1-18, 2021, ISSN: 2169-3536, DOI: 10.1109/ACCESS.2021.3059476
- [J₂]M. Gržanić and T. Capuder, "Coordinated scheduling of renewable energy balancing group," *International Journal of Electrical Power & Energy Systems*, pp. 1-10, February 2021, ISSN: 0142-0615, DOI: 10.1016/j.ijepes.2020.106555
- [J₃]M. Gržanić, T. Capuder, N. Zhang, W. Huang, "Prosumers as active market participants:

A systematic review of evolution of opportunities, models and challenges," *Renewable and Sustainable Energy Reviews*, pp. 1-31, November 2021, ISSN: 1364-0321, DOI: 10.1016/j.rser.2021.111859

[J₄]M. Gržanić, M.G. Flammini, G. Pretico, "Distribution Network Model Platform: A First Case Study," *Energies*, October 2019, ISSN: 1996-1073, DOI: 10.3390/en12214079

[J₅]I. Kuzle, M. Gržanić, N. Holjevac, T. Capuder, H. Pandžić, "The future of energy," *International Journal of Electrical Power & Energy Systems*, pp 106318, December 2020, ISSN : 0142-0615, DOI: 10.1016/j.ijepes.2020.106318

[J₆]M. Gržanić, M. Delimar, and T. Capuder, "Financial Transmission and Storage Rights," *Energija : časopis Hrvatske elektroprivrede*, pp 195-225, 2018

Conference Papers

[C₁]M. Gržanić, M. Zidar, and T. Capuder, "Konveksni optimizacijski modeli za pogon i planiranje naprednih distribucijskih mreža," in *textit13. savjetovanje HRO CIGRÉ*, 2017, Šibenik, Hrvatska

[C₂]M. Bolfek, Z. Matišić, M. Gržanić, and T. Capuder, "Optimizacija uklopnog stanja i naponskih prilika u 35 kV mreži Elektre Koprivnica," in *textit13. savjetovanje HRO CIGRÉ*, 2017, Šibenik, Hrvatska

[C₃]M. Gržanić, T. Capuder, and S. Krajcar, "DSO and Aggregator Sharing Concept for Distributed Battery Storage System," in *2018 IEEE International Conference on Environment and Electrical Engineering and 2018 IEEE Industrial and Commercial Power Systems Europe IEEEIC / I&CPS Europe*, 10.1109/IEEEIC.2018.8493680

[C₄]M. Gržanić and T. Capuder, "Bi-level modelling approach to coordinated operation of wind power plant and PV-storage energy community," in *2018 IEEE International Energy Conference ENERGYCON*, 10.1109/ENERGYCON.2018.8398844

[C₅]V. Salapić, M. Gržanić, and T. Capuder, "Optimal sizing of battery storage units integrated into fast charging EV stations," in *2018 IEEE International Energy Conference ENERGYCON*, 10.1109/ENERGYCON.2018.8398789

[C₆]M. Gržanić and T. Capuder, "Model zajedničkog sudjelovanja aktivnih kupaca i obnovljivih izvora na tržištu električnom energijom," in *6.(12.) savjetovanje HO CIRED-a*, 2018, Opatija, Hrvatska

[C₇]M. Gržanić, Z. Luburić, and Ž. Tomšić, "Pregled postojećih regulativnih okvira za integraciju spremnika energije u EES – prednosti i barijere," in *3. simpozij o sustavu vođenja EES-a Rovinj: Hrvatski ogranak međunarodnog vijeća za velike elektroenergetske sustave – CIGRÉ 2018*, Šibenik, Hrvatska

[C₈]M. Gržanić and T. Capuder, "The Value of Prosumers' Flexibility under Different Elec-

- tricity Market Conditions: Case Studies of Denmark and Croatia," in *2019 IEEE PES GTD Grand International Conference and Exposition Asia GTD Asia*, Bangkok, Thailand, 10.1109/GTDAAsia.2019.8715888
- [C₉]M. Gržanić and T. Capuder, "Podjela troškova električne energije između članova fleksibilne energetske zajednice," in *14. savjetovanje HRO CIGRE*, 2019, Šibenik, Hrvatska, 2019
- [C₁₀]L. Krpina, M. Gržanić, and T. Capuder, "Uloga baterijskih spremnika u niskougličnim elektroenergetskim sustavima," in *14. savjetovanje HRO CIGRE*, Šibenik, Hrvatska
- [C₁₁]A. Hrga, M. Gržanić, T. Capuder, and N. Zhang, "Decentralized Platform for Investments and Operation of Energy Communities," in *IEEE Sustainable Power & Energy Conference Grid Modernization for Energy Revolution Peking*, 2019, Peking, China, 10.1109/iS-PEC48194.2019.8975165
- [C₁₂]M. Gržanić, P. Perović, T. Capuder, and M. Bolfek, "Open source tools for integrated operation and planning of flexible buildings and distribution network," in *Mediterranean Conference on Power Generation, Transmission, Distribution and Energy Conversion - MEDPOWER 2020*, 10.1049/icp.2021.1248
- [C₁₃]M. Miletić, M. Gržanić, I. Pavić, H. Pandžić, T. Capuder, "Dynamic Electricity Pricing Tariffs: Trade-offs for Suppliers and Consumers," in *Mediterranean Conference on Power Generation, Transmission, Distribution and Energy Conversion - MEDPOWER 2020*,
- [C₁₄]M. Gržanić, T. Antić, M. G. Flammini, W. Heinz, G. Pretico, "Renewable energies integration in a DiNeMo model based on a German urban grid," in *CIREC 2020 Berlin Workshop (CIREC 2020)*
- [C₁₅]M. Gržanić, V. Salapić, and T. Capuder, "Dimenzioniranje baterijskog spremnika u punionima električnih vozila," in *7. (13.) savjetovanje HO-CIREC-a*, 2021, Šibenik, Hrvatska
- [C₁₆]M. Gržanić and T. Capuder, "Distribution Network Models (DINEMO) platforma – metodologija i validacija," in *7. (13.) savjetovanje HO-CIREC-a*, 2021, Šibenik, Hrvatska
- [C₁₇]P. Perović, M. Gržanić, and T. Capuder, "Aplikacija za optimizaciju naprednog upravljanja tokovima snaga u distribucijskoj mreži," in *7. (13.) savjetovanje HO-CIREC-a*, 2021, Šibenik, Hrvatska
- [C₁₈]A. Hrga, M. Gržanić, and T. Capuder, "Konceptualno rješenje investicijsko-operativne platforme za energetske zajednice temeljeno na distribuiranim knjigama," in *7. (13.) savjetovanje HO-CIREC-a*, 2021, Šibenik, Hrvatska
- [C₁₉]M. Gržanić, T. Capuder, M. Bolfek, and F. Capitanescu, "A review of practical aspects of existing TSO- DSO coordination mechanisms in Europe and proposal of an innovative hybrid model in ATTEST project," in *EEEIC International Conference on Environment and Electrical Engineering 2021*, Bari, Italy
- [C₂₀]M. Gržanić and T. Capuder, "Collaboration Models Between Distribution System Opera-

tors and Flexible Prosumers," in *International Conference on Applied Energy* 2021

Životopis

Mirna Gržanić je istraživač na Zavodu za visoki napon i energetiku na Fakultetu elektrotehnike i računarstva na Sveučilištu u Zagrebu. Prvostupnica elektrotehnike i informacijske tehnologije je postala u lipnju 2014. godine, a diplomirala je u rujnu 2016. godine na Fakultetu elektrotehnike i računarstva na Sveučilištu u Zagrebu..

Njezini znanstveni interesi obuhvaćaju tranziciju prema održivom elektroenergetskom sustavu iz perspektive krajnjeg korisnika uzimajući u obzir integraciju niskougličnih tehnologija. Njezine istraživačke aktivnosti usmjerene su na razvoj inovativnih cjenovnih modela koji potiču fleksibilno ponašanje krajnjeg korisnika prema potrebama elektroenergetskog sustava. Sudjelovala je u nekoliko znanstvenih projekata financiranih od strane Hrvatske zaklade za znanost i Europske komisije.

Mirna je uključena u nastavu kao asistentica na preddiplomskom studiju u predmetu Elektroenergetika, oformila je i održava nastavu na seminaru Uvod u optimizaciju te aktivno sudjeluje sa studentima u izradi preddiplomskih i diplomskih radova.

Provela je četiri mjeseca (2018.) na specijalizaciji na Sveučilištu u Malagi, u Španjolskoj i pet mjeseci (2019.) u Europskoj komisiji, Joint Research Center Ispra, Italija. Objavila je nekoliko konferencija i znanstvenih radova u časopisima te radila na tehničkim studijama za nacionalnu elektroprivredu.

Mirna je članica profesionalnih organizacija IEEE, CIGRE, INFORMS, PES i IEEE Women in Engineering.