

# Enhanced geothermal system energy projects evaluation model based on multi-criteria decision-making

---

**Raos, Sara**

**Doctoral thesis / Disertacija**

**2023**

*Degree Grantor / Ustanova koja je dodijelila akademski / stručni stupanj:* **University of Zagreb, Faculty of Electrical Engineering and Computing / Sveučilište u Zagrebu, Fakultet elektrotehnike i računarstva**

*Permanent link / Trajna poveznica:* <https://urn.nsk.hr/urn:nbn:hr:168:286015>

*Rights / Prava:* [In copyright](#) / [Zaštićeno autorskim pravom.](#)

*Download date / Datum preuzimanja:* **2024-12-21**



*Repository / Repozitorij:*

[FER Repository - University of Zagreb Faculty of Electrical Engineering and Computing repository](#)





University of Zagreb

FACULTY OF ELECTRICAL ENGINEERING AND COMPUTING

Sara Raos

**ENHANCED GEOTHERMAL SYSTEM ENERGY  
PROJECTS EVALUATION MODEL BASED ON  
MULTI-CRITERIA DECISION-MAKING**

DOCTORAL THESIS

Zagreb, 2023



University of Zagreb  
FACULTY OF ELECTRICAL ENGINEERING AND COMPUTING

Sara Raos

**ENHANCED GEOTHERMAL SYSTEM ENERGY  
PROJECTS EVALUATION MODEL BASED ON  
MULTI-CRITERIA DECISION-MAKING**

DOCTORAL THESIS

Supervisor: Associate Professor Ivan Rajšl, PhD

Zagreb, 2023



Sveučilište u Zagrebu  
FAKULTET ELEKTROTEHNIKE I RAČUNARSTVA

Sara Raos

**MODEL ZA PROCJENU ENERGETSKIH  
PROJEKATA NAPREDNIH GEOTERMALNIH  
SUSTAVA TEMELJEN NA VIŠEKRITERIJSKOM  
ODLUČIVANJU**

DOKTORSKI RAD

Mentor: izv. prof. dr. sc. Ivan Rajšl

Zagreb, 2023.

Doctoral thesis was written at the University of Zagreb Faculty of Electrical Engineering and Computing, Department of Energy and Power Systems, Zagreb, Croatia.

Supervisor: Associate Professor Ivan Rajšl, PhD

Doctoral thesis has: 335

Doctoral thesis number: \_\_\_\_\_

## About the Supervisor

Ivan Rajšl (<https://www.fer.unizg.hr/ivan.rajsl>) was born in 1983 in Slavonski Brod, Croatia. He received his bachelor's and doctoral degrees from the Faculty of Electrical Engineering and Computing, University of Zagreb. At the same Faculty, he was elected as the assistant professor in 2016, and in 2022 as the associate professor. During his doctoral and postdoctoral studies, he spent several months in training at the Norwegian University of Science and Technology - NTNU in Trondheim, Norway.

His area of interest covers energy efficiency, renewable energy sources with emphasis on enhanced geothermal systems, power systems modelling and optimization, distributed energy markets, electricity market modelling and optimization with emphasis on sustainable development goals.

He is the author more than 15 papers in category A journals (majority were published in Q1 and Q2 journals) and more than 25 papers in conference proceedings with international peer-review, and over 20 technical studies.

He is the leader of several international and national research and development projects.

He was one of the members of the program committee of European Energy Market 2011. He is a member of scientific and technical associations HRO CIGRE, Green Energy Cooperative and HUGE (Croatian Geothermal Energy Association).

<https://orcid.org/0000-0002-4383-3147>

<https://scholar.google.hr/citations?user=OKwRKpcAAAAJ&hl=en>

<https://www.researchgate.net/profile/Ivan-Rajsl>

<https://www.bib.irb.hr/pregled/profil/24126>

<https://publons.com/researcher/3748713/ivan-rajsl/>

## O mentoru

Ivan Rajšl (<https://www.fer.unizg.hr/ivan.rajsl>) rođen je 1983. godine u Slavonskom Brodu, Hrvatska. Diplomirao je i stekao doktorat na Fakultetu elektrotehnike i računarstva Sveučilišta u Zagrebu. Na istom fakultetu izabran je za docenta 2016. godine, a 2022. godine za izvanrednog profesora. Tijekom svojih doktorskih i postdoktorskih studija proveo je nekoliko mjeseci na usavršavanju na Norveškom sveučilištu za znanost i tehnologiju - NTNU u Trondheimu, Norveška.

Njegovo područje interesa obuhvaća energetska učinkovitost, obnovljive izvore energije s naglaskom na poboljšane geotermalne sustave, modeliranje i optimizaciju elektroenergetskih sustava, tržišta distribuirane energije, modeliranje i optimizaciju tržišta električne energije s naglaskom na ciljevima održivog razvoja.

Autor je više od 15 radova u časopisima kategorije A (većina je objavljena u časopisima kategorije Q1 i Q2) te više od 25 radova u zbornicima konferencija s međunarodnom recenzijom, te preko 20 tehničkih studija.

Voditelj je nekoliko međunarodnih i nacionalnih istraživačkih i razvojnih projekata.

Bio je član programa Europskog energetskog tržišta 2011. godine. Član je znanstvenih i tehničkih udruga HRO CIGRE, Zelena energetska zadruga i HUGE (Hrvatsko društvo za geotermalnu energiju).

<https://orcid.org/0000-0002-4383-3147>

<https://scholar.google.hr/citations?user=OKwRKpcAAAAJ&hl=enJ>

<https://www.researchgate.net/profile/Ivan-Rajsl>

<https://www.bib.irb.hr/pregled/profil/24126>

<https://publons.com/researcher/3748713/ivan-rajsl/>

## **Zahvala**

Zahvaljujem mentoru izvanrednom profesoru Ivanu Rajšlu na pruženoj prilici da doktoriram pod njegovim mentorstvom.

Hvala svim mojim prijateljima koji su bili uz mene i svojim društvom učinili period doktorskog studija zabavnim i lakšim.

Neizmjereno hvala kolegicama na projektu i prijateljicama Josipi i Teni, koje su bile sa mnom tijekom mog doktorskog studija, od kojih sam puno naučila i koje su me bodrile i pomagale tijekom istraživanja.

Veliko hvala svim članovima moje obitelji koji me podupiru tijekom cijeloga života. Hvala mojim roditeljima koji su ulagali u moje obrazovanje i podupirali moj profesionalni razvoj i napredak. Hvala im svima na neizmjerenoj podršci!



# ABSTRACT

Deep geothermal energy presents substantial untapped renewable energy potential, and deep geothermal systems have the potential to make a significant contribution to global energy requirements in the near future. Nevertheless, the development of geothermal projects is challenged by uncertainties related to efficient geothermal brine extraction and the substantial costs involved in project preparation phases, including site investigation, drilling, and stimulation activities required to establish a viable reservoir within specific geological formations. Consequently, the evaluation of utilization alternatives for such projects emerges as a complex decision-making problem, which can be effectively addressed through the application of multi-criteria decision-making (MCDM) methods. Additionally, large untapped geothermal potential is present in low-permeable and low-porosity rock formations which could be exploitable by implementing Enhanced Geothermal Systems (EGS). However, the EGS, compared to traditional techniques used to exploit conventional systems, i.e., hydrothermal systems are still not commercially viable.

Additionally, the evaluation of investment in EGS projects needs to consider many aspects including geological setting, technology, economics, society, and environmental impact of such project. Therefore, a comprehensive evaluation model is utmost needed to provide substantial help for decision-makers, especially in the preliminary stages of EGS project development. The existing evaluation models, software packages, and tools for the techno-economic assessment of EGS projects do not consider all the abovementioned aspects and are mainly concentrating on the subsurface phenomena. Therefore, one of the goals of this thesis is to provide a comprehensive model capable of assessing all aspects of investing in EGS projects. The developed model is a simulation model and holistically enables the evaluation of EGS projects and applies to a wide range of potential projects in different geological settings and on a wide geographical scale.

Furthermore, since the decision-making related to this topic is a very complex process and should not only be based on the techno-economic assessment, the MCDM methodology was developed and integrated into the developed evaluation model. The proposed MCDM methodology is well-suited for comparing various alternatives for harnessing geothermal energy and evaluating different geothermal production sites. To validate its effectiveness, the evaluation model was used to analyse different case studies. Firstly, an assessment and comparison of different utilization options (heat production, electricity generation, and

combined heat and power production (CHP)) on one geothermal site was performed. Secondly, the assessment and comparison involving demonstration sites situated within three distinct geological conditions (sedimentary rocks, crystalline rocks, and meta-sedimentary rocks) was done. Additionally, three distinct scenarios were conducted, each focusing on different end-use applications: heat production, electricity generation, and CHP. In this case, the MCDM methodology was applied and used to obtain final grades, based on which the alternatives are ranked. Furthermore, it is important to note that the decision-maker's (DM's) perspective and preferences can significantly impact the final decision. Consequently, the outcomes of the project's final assessment can differ depending on the DM's preferences and other subjective factors.

**Keywords:** Deep Geothermal Energy, Enhanced Geothermal Systems, Multi-Criteria Decision-Making, Comprehensive Evaluation Model

# SAŽETAK

## Model za procjenu energetske projekata poboljšanih geotermalnih sustava temeljen na višekriterijskom odlučivanju

Duboka geotermalna energija predstavlja značajan neiskorišteni potencijal obnovljive energije, a duboki geotermalni sustavi imaju potencijal pridonijeti značajnom doprinosu globalnim energetske potrebama u bliskoj budućnosti. Međutim, razvoj geotermalnih projekata suočava se s nesigurnostima vezanim uz učinkovitu ekstrakciju geotermalnog fluida i znatnim troškovima u fazama pripreme projekta, uključujući istraživanje lokacije, bušenje i aktivnosti potrebne za uspostavljanje održivog rezervoara unutar određenih geoloških formacija. Stoga procjena alternativa za takve projekte predstavlja složen problem donošenja odluka, koji se može učinkovito rješavati primjenom metoda višekriterijskog odlučivanja (eng. *multi-criteria decision-making, MCDM*).

Nadalje, veliki neiskorišteni geotermalni potencijal prisutan je u stijinama niske propusnosti i niske poroznosti koje bi se mogle iskoristiti implementacijom poboljšanih geotermalnih sustava (eng. *Enhanced Geothermal Systems, EGS*). Međutim, EGS, u usporedbi s tradicionalnim tehnikama za iskorištavanje konvencionalnih sustava, tj. hidrotermalnih sustava, još nisu komercijalno održivi. Dodatno, procjena ulaganja u EGS projekte mora uzeti u obzir mnoge aspekte, uključujući geološko okruženje, potencijalno primjenjiva tehnologija iskorištavanja geotermalne energije i proizvodnje toplinske i/ili električne energije, ekonomiju, društveni utjecaj i utjecaj na okoliš takvog projekta. Stoga je nužan sveobuhvatan evaluacijski model koji bi pružio značajnu pomoć donositeljima odluka, posebno u početnim fazama razvoja EGS projekata. Postojeći evaluacijski modeli, softverski paketi i alati za tehno-ekonomsku procjenu EGS projekata ne uzimaju u obzir sve navedene aspekte i uglavnom se koncentriraju na podzemne pojave. Stoga je jedan od ciljeva ove doktorske disertacije pružiti sveobuhvatan model sposoban za procjenu svih aspekata ulaganja u EGS projekte. Razvijeni model je simulacijski model koji omogućuje evaluaciju EGS projekata na holistički način i primjenjiv je na širok spektar potencijalnih projekata u različitim geološkim okruženjima i na širem geografskom području.

Budući da je donošenje odluka vezanih za investiranje u geotermalne projekte, s naglaskom na EGS projekte, vrlo složen proces i ne bi se trebalo temeljiti samo na tehno-ekonomskoj procjeni, razvijena je metodologija višekriterijskog odlučivanja (MCDM) te je integrirana u razvijeni evaluacijski model. Predložena MCDM metodologija prikladna je za

usporedbu različitih alternativa za iskorištavanje geotermalne energije i evaluaciju različitih geotermalnih lokacija za proizvodnju toplinske i/ili električne energije. Kako bi se potvrdila njegova učinkovitost, evaluacijski model je korišten u analizi različitih studija slučaja. Prvo je provedena procjena i usporedba različitih opcija korištenja (proizvodnja toplinske energije, proizvodnja električne energije i kombinirana proizvodnja toplinske i električne energije (eng. *combined heat and power production, CHP*)) na jednoj geotermalnoj lokaciji. Drugo, provedena je procjena i usporedba demonstracijskih geotermalnih lokacija smještenih u tri različita geološka okruženja (sedimentarne stijene, granitne stijene i metasedimentne stijene). Dodatno, analizirana su tri različita scenarija, svaki usmjeren na različite primjene krajnjeg korisnika: proizvodnju toplinske energije, proizvodnju električne energije i CHP. U ovom slučaju, MCDM metodologija primijenjena je i korištena za dobivanje konačnih ocjena, na temelju kojih se alternative rangiraju od najbolje do najlošije. Također, važno je napomenuti da perspektiva i preferencije donositelja odluka mogu značajno utjecati na konačnu odluku projekta. Stoga se rezultati konačne ocjene projekta mogu razlikovati ovisno o preferencijama donositelja odluka i drugim subjektivnim faktorima.

Stoga, temeljeno na gore navedenom, ovo istraživanje ima tri glavna cilja. Prvi cilj bio je istražiti i evaluirati glavne utjecajne faktore koji trebaju biti analizirani prilikom modeliranja tehničkih, ekonomskih i ekoloških procjena poboljšanih geotermalnih sustava. Drugi cilj bio je razvoj integrirane metodologije višekriterijskog odlučivanja koja će omogućiti potencijalnim investitorima da provedu preliminarnu komparativnu analizu upotrebe tehnologije EGS na različitim potencijalnim lokacijama. Treći cilj bio je razvoj evaluacijskog modela za odabir najboljeg rješenja za iskorištavanje dostupnog geotermalnog potencijala i integraciju EGS-a u sustave grijanja i proizvodnje električne energije.

Originalni znanstveni doprinos doktorske disertacije sastoji se od tri dijela, a svaki dio ukratko je objašnjen u nastavku teksta:

- (1) Metoda za standardiziranu evaluaciju utjecajnih kriterija u vezi s investicijama u projekte energije poboljšanih geotermalnih sustava.

Prvi dio doprinosa predstavlja metodu za evaluaciju kriterija koji su identificirani i definirani kao od velikog utjecaja na investicije u projekte energije poboljšanih geotermalnih sustava. Utjecajni kriteriji obuhvaćaju sve važne aspekte pri investiranju u projekte EGS: geološko okruženje, tehnologiju, ekonomiju/financije, utjecaj na okoliš i društvo. Dodatno, neki kriteriji su kvantitativno definirani, dok

su drugi kvalitativno definirani. Stoga metoda pruža standardizirani postupak za evaluaciju kriterija neovisan o prirodi određenog kriterija.

- (2) Integrirana metodologija težinskog i rangiranja višekriterijskog donošenja odluka za evaluaciju i usporedbu različitih opcija za pretvorbu geotermalne energije u električnu energiju i toplinu.

Drugi dio doprinosa sastoji se od integrirane metodologije višekriterijskog donošenja odluka za evaluaciju pojedinačnih opcija projekta i/ili usporedbu različitih opcija za pretvorbu geotermalne energije u korisnu energiju te usporedbu različitih lokacija za iskorištavanje geotermalne energije. Naime, definirani utjecajni kriteriji često su konfliktni, stoga je kako bi se dobilo najbolje rješenje iz skupa alternativa (opcija projekta) potrebno primijeniti različite metode donošenja odluka. Stoga predložena metodologija kombinira metodu težinskog procjenjivanja Analitičkih hijerarhijskih procesa (AHP) i metodu rangiranja Više Kriterijumska Optimizacija I Kompromisno Rešenje (VIKOR) kako bi se dobilo i prikazalo najbolje rješenje iz skupa alternativa.

- (3) Model za evaluaciju i usporedbu različitih lokacija za proizvodnju geotermalne električne energije i toplinske energije temeljen na višekriterijskom donošenju odluka.

Komercijalno iskorištavanje energije iz geotermalnih izvora niskih do srednjih temperatura te iz stijena niske poroznosti i niske propusnosti još je u svojim počecima, uglavnom zbog toga što su investicije u takve projekte složene i vrlo specifične za svaku lokaciju. Razvijeni model evaluacije mogao bi pomoći donositeljima odluka pri procjeni potencijalnih investicija u projekte korištenja geotermalne energije, s naglaskom na projektima EGS. Stoga bi razvijeni model evaluacije mogao povećati vidljivost takvih projekata i razumijevanje potencijalnih koristi, što bi moglo dovesti do veće penetracije EGS na postojećem tržištu.

Disertacija je podijeljena u sedam poglavlja. Svako poglavlje započinje kratkim sažetkom koji služi kao kratki sažetak poglavlja. Nakon sažetka, čitatelj postupno ulazi u temu svakog poglavlja. U prvome poglavlju dan je uvod u disertaciju, gdje je predstavljena pozadina i motivacija. Naime, pozadinu disertacije predstavlja potencijal geotermalne energije i EGS tehnologije kao održivog izvora energije, dok motivacija proizlazi iz potrebe za inovativnim alatima za podršku donošenju odluka i metodologijama za snalaženje u kompleksnostima

evaluacije i investiranja u EGS projekte. Također, opisuju se dijelovi znanstvenog doprinosa, kao i kratki sažetak svakog poglavlja disertacije.

Drugo poglavlje predstavlja uvodno istraživanje geotermalne energije kao održivog i obećavajućeg izvora energije. Počinje prednostima i nedostacima geotermalne energije, a zatim opisuje glavne opcije korištenja geotermalne energije (proizvodnja toplinske energije, proizvodnja električne energije i kombinirana proizvodnja toplinske i električne energije (CHP)). Nakon toga, objašnjen je koncept EGS-a, koji omogućava iskorištavanje ogromnog geotermalnog potencijala koji nije iskoristiv konvencionalnim tehnikama i modelima. Dodatno, predstavljeni su EGS projekti diljem svijeta, a u posljednjem dijelu ovog poglavlja navedene su prepreke i izazovi veće implementacije EGS-a na postojećem tržištu.

Treće poglavlje pruža pregled postojećih modela i softverskih paketa za procjenu EGS projekata, uglavnom u pogledu tehno-ekonomske evaluacije. Ti postojeći modeli i alati kratko su opisani prema kronološkom redu njihovog razvoja i pojavljivanja u javnoj domeni. Poglavlje završava komparativnom analizom predstavljenih alata.

U četvrtom poglavlju predstavljeno je specijalizirano područje modela operacijskog istraživanja. Ovo područje obuhvaća metode višekriterijskog odlučivanja (eng. MCDM), koje su instrumentalne u procesu donošenja odluka. Donošenje odluka je složen proces identifikacije i odabira najprikladnijeg rješenja među različitim alternativama, uzimajući u obzir mnoge čimbenike i očekivanja uključenih donositelja odluka. Opisane su četiri glavne faze procesa MCDM-a. U svakoj fazi procesa MCDM-a može se koristiti različita MCDM metoda. Stoga je pružen sveobuhvatan pregled metoda odabira kriterija, metoda ponderiranja (određivanja težina) i metoda rangiranja. Poglavlje završava tabličnom usporedbom najčešće korištenih metoda MCDM-a.

U petom poglavlju predstavljena je i detaljno opisana razvijena integrirana metodologija višekriterijskog odlučivanja (MCDM). Ova metodologija sadrži tri osnovne komponente: metodu za standardiziranu evaluaciju utjecajnih kriterija (faktora koji značajno utječu na odluke pri investiranju u EGS projekte), metodu analitičkog hijerarhijskog procesa (AHP) koja se koristi za određivanje težina svakoga kriterija i VIRKOR metodu koja se koristi za rangiranje alternativa. Poglavlje započinje objašnjenjem procesa odabira kriterija, sažimajući sveobuhvatan set od dvadeset i osam utjecajnih kriterija. Zatim dublje ulazi u metodu za standardiziranu evaluaciju tih kriterija, obuhvaćajući jedinstven sustav ocjenjivanja svakog kriterija. Naposljetku, poglavlje pruža detaljan opis integrirane metode ponderiranja i

rangiranja, uz provedenu analizu studija slučaja i prezentaciju rezultata dobivenih primjenom metodologije.

Šesto poglavlje pruža sveobuhvatan i detaljan opis evaluacijskog modela specifično razvijenog za procjenu projekata poboljšanih geotermalnih sustava (EGS). Osnovni cilj ovog modela je olakšati komparativnu analizu različitih scenarija za EGS projekte. To uključuje ispitivanje različitih opcija korištenja geotermalne energije na određenim geotermalnim lokacijama, kao i usporedbu različitih geotermalnih lokacija s istom opcijom korištenja. Poglavlje opisuje proces razvoja modela, objašnjava primijenjeni pristup modeliranju i pruža detaljan opis sastavnih komponenata koje čine evaluacijski model. Nadalje, prikazan je i opisan alat za podršku odlučivanju, razvijen kao samostalna aplikacija koju odlikuje korisničko sučelje koje je jednostavno za korištenje. Poglavlje također prikazuje praktičnu primjenu modela za usporedbu različitih opcija korištenja geotermalne energije na određenim lokacijama i ocjeni različitih geotermalnih lokacija za istu opciju korištenja geotermalne energije. Rezultati dobiveni iz ovih analiza opsežno su predstavljeni i analizirani unutar ovog poglavlja.

U posljednjem, sedmom poglavlju disertacije dani su zaključci i sažetak predstavljenog znanstvenog doprinosa. Dodatno, pružene su mogućnosti za daljnji razvoj evaluacijskog modela.

**Ključne riječi:** Duboka geotermalna energija, Poboljšani geotermalni sustavi (eng. *Enhanced Geothermal Systems, EGS*), Metode višekriterijskog odlučivanja, Sveobuhvatni evaluacijski model

# Contents

1	INTRODUCTION.....	1
1.1.	Background and motivation .....	1
1.2.	Objective of the thesis and original contribution .....	4
1.3.	Outline of the thesis.....	5
2	GEOTHERMAL SYSTEMS .....	9
2.1.	Preamble.....	9
2.2.	Geothermal energy .....	10
2.2.1.	Geothermal resource types .....	13
2.2.2.	Heat transport and thermal properties .....	15
2.2.3.	Permeability and porosity .....	17
2.3.	Applications of geothermal energy .....	18
2.3.1.	Direct usage .....	20
2.3.2.	Electricity generation.....	22
2.3.3.	Combined heat and power production (CHP) .....	25
2.4.	Defining Enhanced Geothermal Systems (EGS).....	26
2.4.1.	EGS potential.....	29
2.4.2.	Development of an EGS power plant .....	31
2.4.2.1.	Finding a site .....	31
2.4.2.2.	Creating a reservoir .....	31
2.4.2.3.	Operating the reservoir .....	32
2.4.3.	EGS projects worldwide .....	33
2.4.4.	Barriers and challenges for establishing enhanced geothermal energy utilization plan .....	36
3	AN OVERVIEW OF EXISTING TECHNO-ECONOMIC EVALUATION MODELS AND SOFTWARE PACKAGES (TOOLS).....	39
3.1.	Preamble.....	39
3.1.1.	GEOPHIRES .....	41
3.1.2.	GETEM .....	43
3.1.3.	EURONAUT .....	44
3.1.4.	GEOELEC.....	45
3.1.5.	ENGINE .....	45
3.1.6.	SAM .....	46
3.2.	Comparison of available techno-economic models and software packages.....	46
4	MULTI-CRITERIA DECISION-MAKING .....	49
4.1.	Preamble.....	49
4.2.	General approach.....	53
4.2.1.	Basic notation .....	55
4.3.	Criteria selecting methods .....	56
4.3.1.	Delphi method .....	57
4.3.2.	Least mean square (LMS) method.....	57



4.4. Weighting methods.....	58
4.4.1. Subjective weighting methods.....	59
4.4.2. Objective weighting methods .....	60
4.4.3. Combination weighting methods.....	61
4.5. Ranking methods.....	61
4.5.1. Elementary methods .....	62
4.5.2. Unique synthesizing criteria methods.....	62
4.5.3. Outranking methods .....	64
4.5.4. Other methods.....	66
4.6. Comparison of most commonly used MCDM methods.....	67
5 MCDM METHODOLOGY .....	69
5.1. Preamble.....	69
5.1.1. Criteria in energy projects planning .....	71
5.1.2. Geothermal energy (EGS) projects evaluation approach .....	72
5.1.3. Decision-making process associated to geothermal energy projects.....	73
5.2. Identification and definition of influencing criteria related to investments in EGS energy projects.....	77
5.2.1. Overview of many influencing factors on EGS implementation and integration .....	77
5.2.2. Criteria selecting method – the Delphi method .....	82
5.3. Method for standardized evaluation of defined influencing criteria .....	84
5.3.1. Grading thresholds for defined influencing criteria.....	86
5.3.1.1. Permeability.....	87
5.3.1.2. Porosity.....	88
5.3.1.3. Reservoir type.....	90
5.3.1.4. Reservoir volume.....	90
5.3.1.5. Reservoir temperature .....	91
5.3.1.6. Reservoir depth.....	92
5.3.1.7. Fluid heat capacity.....	94
5.3.1.8. Capacity factor.....	95
5.3.1.9. Deployment duration .....	96
5.3.1.10. Proximity to the grid.....	97
5.3.1.11. Global efficiency .....	99
5.3.1.12. Wellhead temperature.....	100
5.3.1.13. Flow rate.....	101
5.3.1.14. Injection temperature.....	102
5.3.1.15. Levelized cost of energy (LCOe) .....	104
5.3.1.16. Net present value (Equivalent annual annuity) .....	106
5.3.1.17. Capital costs.....	107

5.3.1.18.	Operation and maintenance costs (O&M costs).....	109
5.3.1.19.	Discounted payback period .....	110
5.3.1.20.	Support schemes .....	111
5.3.1.21.	Job creation.....	112
5.3.1.22.	Social acceptability.....	113
5.3.1.23.	Land use.....	113
5.3.1.24.	Noise.....	114
5.3.1.25.	Avoided CO <sub>2</sub> emissions.....	114
5.3.1.26.	Protected areas.....	118
5.3.1.27.	Potential seismicity.....	119
5.3.1.28.	Conflict with other subsurface uses.....	122
5.3.2.	Case study - results .....	124
5.3.2.1.	Scenario Heat.....	126
5.3.2.2.	Scenario Electricity .....	126
5.3.2.3.	Discussion.....	127
5.3.2.4.	Sensitivity analysis of LCOE for ‘Scenario Electricity’ .....	133
5.4.	Integrated MCDM Methodology.....	136
5.4.1.	Weighting method – Analytic Hierarchy Process (AHP).....	138
5.4.1.1.	Primary functions of AHP method.....	140
5.4.1.2.	Principles and axioms of AHP method .....	140
5.4.1.3.	AHP method workflow.....	143
5.4.1.4.	Case study.....	148
5.4.1.4.1.	AHP hierarchical structure .....	149
5.4.1.4.2.	Results (combined) and discussion.....	151
5.4.1.4.3.	Detailed analysis of results by stakeholder group .....	159
5.4.1.4.4.	Detailed analysis by expertise background of respondents ..	164
5.4.2.	Ranking method – VIKOR.....	167
5.4.2.1.	Background of VIKOR method.....	168
5.4.2.2.	VIKOR method workflow .....	169
5.4.2.3.	Case study.....	170
5.4.2.3.1.	Results .....	173
5.4.2.3.2.	Detailed analysis of results by stakeholder group .....	174
5.4.2.3.3.	Detailed analysis of results by expertise background of respondents.....	176
6	EVALUATION MODEL.....	179
6.1.	Preamble.....	179
6.2.	Development process.....	181
6.2.1.	Approach and concept for evaluation model development .....	181

6.2.1.1. Geothermal project depiction .....	185
6.2.2. MATLAB software.....	186
6.3. Project sizing – geothermal energy utilization modes.....	189
6.3.1. Reservoir productivity decline.....	190
6.3.2. Only heat production mode .....	191
6.3.2.1. Heat production calculation.....	192
6.3.2.2. Heat exchanger area calculation.....	195
6.3.3. Only electricity production mode .....	197
6.3.3.1. ORC installed capacity .....	199
6.3.3.2. Electricity production calculation.....	205
6.3.4. CHP production mode in series configuration .....	206
6.3.4.1. Energy production .....	208
6.3.5. CHP production mode in parallel configuration.....	209
6.3.5.1. Energy production .....	211
6.4. Financial analysis .....	216
6.4.1. Capital costs.....	218
6.4.1.1. Permitting costs correlations .....	219
6.4.1.2. Exploration costs correlations .....	220
6.4.1.3. Drilling costs correlations.....	221
6.4.1.4. Pumping systems costs correlations .....	222
6.4.1.5. Power plant equipment costs correlations .....	223
6.4.1.6. Power grid connection conditions and costs .....	227
6.4.1.7. Heating network connection costs.....	230
6.4.2. Operating and maintenance costs (O&M) .....	231
6.4.2.1. Annual labour costs .....	232
6.4.2.2. Annual wellfield maintenance costs.....	233
6.4.2.3. Annual power plant maintenance costs .....	233
6.4.3. Incentives.....	233
6.4.4. Calculation of levelized cost of energy .....	234
6.4.5. Financial profitability .....	236
6.4.5.1. NPV and IRR on investment .....	236
6.4.5.2. NPV and IRR on capital .....	237
6.4.6. Financial sustainability .....	238
6.5. Internal databases .....	238
6.6. Decision-support tool – a standalone application.....	240
6.6.1. GUI – main window .....	240
6.6.2. Scenario definition.....	241
6.6.3. Gathering all relevant input data via sub-applications .....	242

6.6.4. Preparing data and executing financial analysis of the project .....	245
6.6.4.1. Performance metrics results .....	246
6.6.4.2. Economic metrics results.....	247
6.6.5. MCDM analysis.....	249
6.6.6. Oil-to-Water conversion methodology .....	250
6.7. Testing of the evaluation model and decision-support tool.....	251
6.7.1. Comparison of different geothermal energy utilization options at the same geothermal site.....	252
6.7.1.1. Chosen site general information.....	253
6.7.1.2. Analysis methodology .....	253
6.7.1.3. Electricity generation scenario .....	255
6.7.1.3.1. Analysis of results.....	258
6.7.1.4. District heating scenario .....	261
6.7.1.4.1. Analysis of results.....	264
6.7.1.5. CHP scenario .....	267
6.7.1.5.1. Analysis of results.....	269
6.7.2. Comparison of development of EGS project at different geothermal sites....	272
6.7.2.1. Chosen sites' general information .....	274
6.7.2.2. Analysis methodology .....	275
6.7.2.3. Heat production scenario .....	280
6.7.2.3.1. Analysis of results.....	281
6.7.2.4. Electricity generation scenario .....	283
6.7.2.4.1. Analysis of results.....	285
6.7.2.5. CHP scenario .....	287
6.7.2.5.1. Analysis of results.....	288
6.7.2.6. MCDM analysis results .....	290
7 CONCLUSIONS AND FUTURE DEVELOPMENT .....	293
BIBLIOGRAPHY .....	297
APPENDIX A.....	315
A1. AHP supplementary data.....	315
Biography.....	329
Full list of publications .....	331
Journal publications.....	331
Conference publications .....	333
Životopis .....	335

## INTRODUCTION

THE INTRODUCTION CHAPTER provides the background and the motivation behind the research conducted within the scope of this thesis. First, the development of Enhanced Geothermal Systems (EGS) is explained in terms of enabling the exploitation of vast geothermal potential on a wider geographical and temperature scale. Afterward, the multi-criteria decision-making (MCDM) process is shortly introduced, especially related to the investments in geothermal energy utilization projects which leads to the motivation for development of and evaluation model for a comprehensive assessment of EGS projects. Thereafter, the objective of the thesis is presented alongside with the original contribution of the thesis which can be divided into three main parts. Each part of the scientific contribution is shortly described. This chapter is concluded with brief outline of the thesis, providing short description of each chapter.

### 1.1.BACKGROUND AND MOTIVATION

Geothermal energy is a ubiquitous renewable energy source. However, currently only a small fraction of available geothermal potential is used for electricity generation, or to provide heat for commercial, industrial, and residential sectors. Namely, huge potential is present at high depths, i.e., in deep geothermal systems, whose development is associated with high technical and economic risks at the exploration stage as much as large upfront costs related to well-drilling and potential reservoir stimulation.

Existing technology for exploiting the geothermal capacity is commercially applicable for exploitation of conventional systems, i.e., hydrothermal systems. In contrast to these technologies, the systems that require technical enhancement through hydraulic, thermal, or chemical stimulation methods or advanced well configurations, are lately defined as Enhanced Geothermal Systems (EGS). This definition is not only related to low permeability conductive petrothermal systems, but also to low productivity convective hydrothermal systems that require technical enhancement in order to increase the productivity of the system [1]. The EGS concept consists of creating a fracture system in the targeted geological formation used for the injected geothermal fluid circulation. Namely, the EGS power cycle requires continuous water injection through injection well. The fluid then circulates through

created pathways where it is heated and then brought back to the surface using a second, production well. At the surface, the heat is usually extracted in the binary cycle to generate electricity or is used for direct heat applications.

The geothermal energy market is predicted to grow, and it is expected that research and development trends in exploration, drilling and fracturing processes will continuously be adapted from the oil and gas industry. Despite the growing interest in the utilization and development EGS for geothermal energy extraction, it is important to note that the EGS technology has not yet reached a level of maturity that allows it to compete on a commercial scale with other renewable resources like wind and solar power. Despite the fact that EGS technology has been developed over the past 40 years in several countries [2], [3], almost all 18 significant EGS pilot power plants [3], need to be jointly founded by governments and/or other state related entities. In other words, a growing interest in the applications of the enhanced systems and medium-to-low temperature geothermal resources can be observed in the last decades with an increased attention shown to the possibilities of developing EGS in last five years, especially in countries like USA, Iceland, Britain, Germany, China, Portugal, and the Netherlands [4], but often a reference frame in this field does not exist. Different expertise backgrounds and actors with different points of view are involved in the design and optimization of geothermal projects. Namely, decision making in geothermal projects requires consideration of geological, technical, economic, environmental, and societal impacts. Therefore, this process is often very complex and requires evaluation of numerous different criteria while simultaneously satisfying preferences of involved actors with different points of view. When considering geothermal project those actors may include group of individuals, administration authorities on local or regional level, local communities, academic institutions, environmental groups, and governmental bodies that through their evaluation systems and priorities have interests at stake and indirectly or directly influence the decision-making process.

The decision-making associated to geothermal energy presents multidimensional problem that encompasses complex interaction between socio-environmental, techno-economic, and geophysical factors. Based on literature review, identified problems and solutions could be classified into four homogeneous problem classes. The problem classes include source selection; geothermal potential; location selection; and technologies performance. In [5], various technical characteristics, resource availability, socio-economic, environmental, political, legal and organizational aspects were incorporated in the Analytic Hierarchy Process (AHP) model for evaluating and prioritizing different power plants, including geothermal. In

[6], a comparative analysis of ranking renewable energy sources for electricity in Taiwan using four different multi-criteria decision-making (MCDM) methods was presented. The geothermal energy resulted as fifth best option and additionally it was demonstrated that each MCDM method has its advantages and disadvantages, and neither method is dominating other methods. Geothermal resource potential areas are mostly assessed using different GIS-based models and methods [7]–[12] based on main geological and geophysical data. Furthermore, theoretical, technical, and economic potential of EGS systems is assessed on a global scale in [13] and in Europe in [14], [15].

Determining optimal position and location for geothermal plant installation is a crucial step that precedes the technical development of the project. Possible EGS locations have been investigated on both global [16], [17] and regional/local [18], [19] scale. Effectiveness of an EGS power plant depends on the suitability of an area to geothermal energy extraction/production, which is a complex and unknown combination of many geological, environmental, and societal factors. Additionally, as indicated in [20], siting EGS in rural and urban areas involves trading off benefits of sold heat, avoided CO<sub>2</sub> emissions, and induced seismicity risk.

Technology selection and performance assessment are essential for an investment to be economically feasible. The study [21] proposed a selection matrix to choose between two different technologies, the traditional doublet and wellbore heat exchanger, in order to convert a hydrocarbons fields into a geothermal one for direct usage of heat. The two proposed technologies are compared based on the defined set of nine indexes, which include technological indexes, environmental indexes, and cost indexes. Each index is, based on the defined thresholds for each index, evaluated with a value between 0 and 1, with 0 being unfavourable and 1 highly favourable. An updated version of this selection matrix was proposed in [22] aiming to provide an evaluation instrument of two different geothermal plants, as well as to highlight dependence of the results on the weight that the decision maker assigns to each index. This decision making matrix served as basis and was expanded in [23] to provide wider applicability, in other words to enable assessment of the geothermal potential of mature hydrocarbon fields in more broader context.

Based on the literature, it can be observed that different approaches can be applied when considering decision-making process in scope of investment in EGS projects and geothermal energy in general. However, characteristic to the surveyed approaches is that they concentrate exclusively on geological and geophysical criteria [8]–[13], [15], [18], [19], [24] exclusively on technological criteria [25], exclusively on environmental criteria [26], [27], or some

combination of techno-economic [28], environmental [29] and societal criteria [20]–[22], [30]. In [14], [31] geological, but also techno-economic criteria have been considered, and some environmental and societal criteria can be found in [23].

## 1.2. OBJECTIVE OF THE THESIS AND ORIGINAL CONTRIBUTION

This research has three main objectives. The first objective was to investigate and evaluate the main influencing factors that need to be analysed when modelling technical, economic, and environmental assessments of enhanced geothermal systems. The second objective was the development of an integrated multi-criteria decision-making methodology that will allow potential investors to conduct preliminary comparative analysis of EGS technology application at different potential locations. The third objective was the development of the evaluation model for selection of the best solution for the utilisation of available geothermal potential and integration of the EGS into the heating and power systems.

The research hypotheses are:

- Standardized evaluation of influencing criteria when investing in geothermal energy projects, with emphasis on enhanced geothermal systems, can enable preliminary identification of project potential and cost-effectiveness as well as comparison of several potential projects, and
- Potential and profitability of investments in geothermal energy projects, with emphasis on enhanced geothermal systems, is conditioned by geological and economic factors, societal and environmental factors as well as the subjective perspective of investors.

The original scientific contribution of the thesis consists of three parts and each part is briefly elaborated in the following text:

- (1) Method for standardized evaluation of influencing criteria related to investments in enhanced geothermal system energy projects.

The first part of the contribution presents the method for evaluation of criteria that were identified and defined to have significant influence on investments in enhanced geothermal system energy projects. The influencing criteria cover all important aspects when investing in EGS projects: geological setting, technology, economy/finance, environmental, and societal impact. Additionally, some criteria are quantitatively, and others qualitatively defined. Therefore, the method provides



standardized process for criteria evaluation independent from the nature of a certain criteria.

- (2) An integrated weighting and ranking multi-criteria decision-making methodology for the evaluation and comparison of different options for the transformation of geothermal energy into electricity and heat.

The second part of the contribution consists of integrated multi-criteria decision-making methodology for evaluation of single project option and/or comparison of different options for geothermal energy transformation into useful energy and comparison of different locations for geothermal energy exploitation. Namely, the defined influencing criteria are often conflicting, and therefore, to obtain the best solution from a set of alternatives (project options) it is necessary to apply different decision-making methods. Therefore, the proposed methodology combines weighting method Analytic Hierarchy Process (AHP) and ranking method *Više Kriterijumska Optimizacija I Kompromisno Rešenje* (VIKOR) to obtain and present the best solution for a set of alternatives.

- (3) Model for the evaluation and comparison of different geothermal sites, regarding electricity and heat production, based on multi-criteria decision-making.

Commercial exploitation of geothermal energy from low- to medium-temperature, and low-porosity and low-permeable geothermal sources is still at its rudiments mainly because of investment in such projects are complex and highly site specific. The developed evaluation model aims to assist the decision-makers when assessing the potential investments in geothermal energy utilization projects, emphasizing EGS projects. Consequently, the developed evaluation model could increase the visibility of such projects and increase the understanding of potential benefits, which could lead to higher penetration of EGS, as well as other geothermal projects, into the existing market.

### 1.3. OUTLINE OF THE THESIS

This thesis is organized into seven chapters. Each chapter begins with a short abstract which serves as a brief chapter summary. Afterwards, the reader is gradually introduced with the topic of each chapter in a section called preamble. Hereafter, the outline of this thesis with each chapter 's brief summary content is as following:

- Ch 2 This chapter serves as an introductory exploration into the field of geothermal energy as a sustainable and promising energy source. It starts with advantages and disadvantages of geothermal energy, followed by description of main utilization options of geothermal energy (heat production for heating purposes, electricity generation, and combined power and heat production (CHP)). Afterward, the EGS concept is explained, which enables exploitation of huge geothermal potential which is not exploitable by conventional geothermal techniques and models. Additionally, worldwide EGS projects are briefly summarized and barriers and challenges of large scale EGS implementation into existing market are identified in the last Section of this chapter.
- Ch 3 This chapter provides an overview of existing models and software packages for assessment of EGS projects, mainly in terms of techno-economic evaluation. Those existing models and tools are briefly described in chronological order of their development stages and appearance in the public domain. The chapter is concluded with a comparative analysis of these tools.
- Ch 4 This chapter serves as an in-depth exploration into a specialized branch of Operations Research models. This branch encompasses multi-criteria decision-making (MCDM) methods, which are instrumental in the process of decision-making. Decision-making itself is the intricate process of identifying and selecting the most suitable solution among various alternatives, taking into account a multitude of factors and the expectations of the involved decision-makers. Four main stages of MCDM process are identified and described. In each stage of the MCDM process, different MCDM method can be used. Therefore, a comprehensive overview of criteria selection methods, weighting methods, and ranking methods is provided. To offer as clear as possible understanding, the chapter concludes with a tabular comparison of the most frequently used MCDM methods.
- Ch 5 This chapter presents developed integrated multi-criteria decision-making (MCDM) methodology. This methodology comprises three core components: a method for the standardized evaluation of influential criteria (factors that significantly impact decisions when investing in EGS projects); the Analytic Hierarchy Process (AHP) method utilized for weighting; and the VIKOR method employed for ranking. The chapter initiates by explaining the process of criteria selection, outlining a comprehensive set of twenty-eight influential criteria.

Subsequently, it delves into the method for the standardized evaluation of these criteria, encompassing a uniform grading system for each criterion. Finally, the chapter provides an in-depth description of the integrated weighting and ranking method, culminating in the presentation of the outcomes derived from the implemented methodology.

- Ch 6 This chapter presents a comprehensive overview of the evaluation model specifically developed for assessing Enhanced Geothermal System (EGS) projects. The primary aim of this model is to facilitate the comparative analysis of various scenarios related to EGS projects. This includes the examination of different geothermal energy utilization options within specific geothermal sites, as well as the comparison of distinct geothermal sites with regard to the same utilization option. The chapter delineates the model's development process, elucidates the modelling approach that was adopted, and provides detailed descriptions of the evaluation model constituent components. Furthermore, it introduces a decision-support tool, manifested as a standalone application characterized by its user-friendly graphical user interface. The chapter also showcases the practical application of the model in comparing various geothermal energy utilization options within specific sites and in assessing different geothermal sites for the same utilization option. The outcomes derived from these analyses are presented comprehensively in scope of this chapter.
- Ch 7 This chapter provides conclusion of this thesis and gives a summary of presented scientific contribution. Additionally, some insights are given for further upgrade and development of the evaluation model.



## **GEOHERMAL SYSTEMS**

THIS CHAPTER provides an introductory exploration into the field of geothermal energy as a sustainable energy source. It opens by delving into the advantages and disadvantages associated with geothermal energy. Notably, geothermal energy offers diverse applications, broadly categorized into three primary groups: direct utilization for heating purposes; electricity generation; and the combined production of heat and power (CHP). While the global potential for geothermal energy is vast, its effective exploitation has often been constrained by economic and technical limitations and limited to exploitation mainly by means of traditional hydrothermal systems. This chapter introduces a groundbreaking technology known as Enhanced Geothermal Systems (EGS), which has significantly expanded the scope for harnessing geothermal potential across a wider geographic and temperature range. The EGS concept is explained herein. Moreover, this chapter undertakes a systematic review of EGS projects worldwide, drawing from publicly available information. It is important to note that the majority of these projects have been primarily pilot endeavours, often funded by various governmental or institutional sources. Commercially operating EGS projects remain relatively rare in practice. The chapter aims to present the current state-of-the-art in EGS projects globally, offering informative insights associated to strategies for achieving higher levels of EGS implementation. In the final section (Section 2.4.4), the chapter delves into the barriers and challenges associated with the implementation and penetration of EGS into existing market. These challenges encompass institutional, regulatory, technological, and financial dimensions, collectively shaping the landscape of EGS adaptation.

### **2.1. PREAMBLE**

The growing concern around rising energy costs, the dependence on fossil fuels, and the environmental impact of energy supply makes it necessary to find economical and environment-friendly energy alternatives. Renewable energy technologies have experienced a breakthrough in recent decades and a rising number of countries have been complying with the decarbonization targets agreed to in the Paris Agreement, as well as setting pledges to

reach net-zero emissions by mid-century. Overall renewable energy capacity additions rose by almost 13% to nearly 340 GW in 2022 [32]. The largest share in newly installed power capacities around the world is covered by solar and wind power plants, with net additions of nearly 220 GW and 74 GW, respectively [32].

Besides those two renewable sources, geothermal energy also represents large untapped renewable potential with rather low environmental impact, especially regarding greenhouse gases emissions. However, geothermal energy in electricity generation has grown at a modest rate of around 3.5% annually, reaching a total installed capacity of approximately 15.96 gigawatts electric (GWe) in 2021. As a result, geothermal energy still accounts for a mere 0.5% of renewables-based installed capacity for electricity generation, and heating and cooling, globally [33].

## 2.2. GEOTHERMAL ENERGY

Generally, geothermal energy is the thermal energy stored in the Earth's crust. This thermal energy originates from radioactive decay of minerals and from solar energy absorbed at the Earth surface. The Earth has a layered internal structure (Figure 2.1) with a solid core of high-density materials, an iron-nickel alloy surrounded by an outer core of the same material in a low-viscosity state. A thick internally layered, viscous magnesium silicate mantle encloses the core. The surface zone of the planet is build-up of a thin rigid crust, whose composition differs between continents and oceans [34]. The lithosphere is the rigid lid of the planet that is subdivided into a series of mobile plates that move individually as a result of pull and drag forces exerted by the convective motion of the mantle. The lithospheric mantle is separated from the crust by the petrographic MOHO layer and consists of the same rock types as the mantle as a whole. The mantle creates distinct thermal regimes at the Earth surface resulting from upwelling and subsiding hot mantel material and from the mechanical and thermal response of the lithosphere. Extending lithosphere creates rift and graben structures typically with a pronounced thermal response at the surface [34].

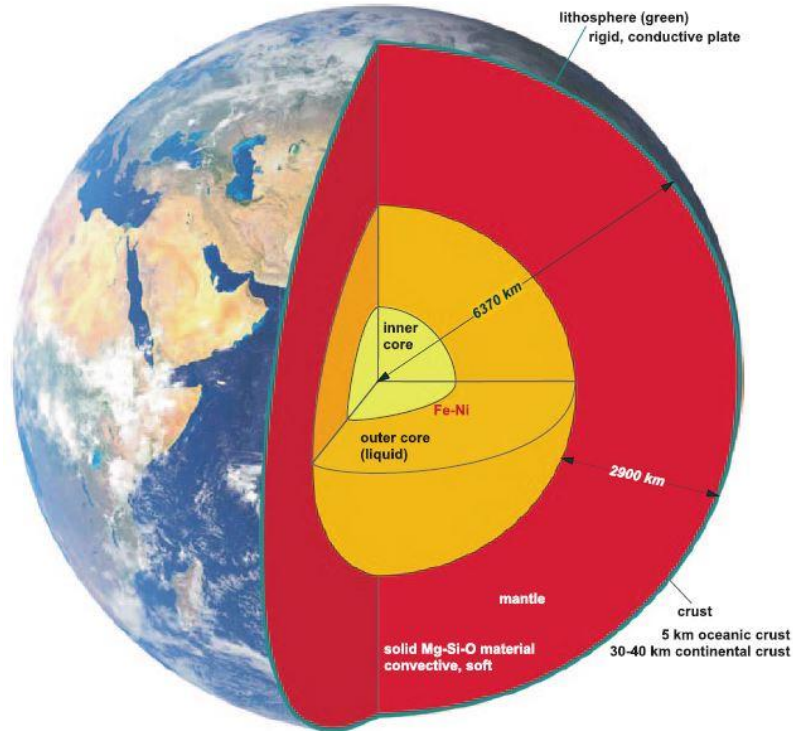

Figure 2.1. Internal structure of the Earth (source: [34])

The geothermal resource base consists of thermal energy stored in the Earth's crust to a prescribed depth—usually taken to be about 10 km, which is accessible using currently available drilling technologies. The average temperature at the Earth's surface is 14 °C, at the core-mantle boundary temperature is around 3,000 °C. This temperature difference ( $\Delta T$ ) between the surface and the interior is the driving force for heat flow, which tries to eliminate  $\Delta T$ . The process is known as so-called Fourier conduction. Heat is continuously transported from the hot Earth interior to the colder surface. The terrestrial heat flow is the amount of energy (J) transferred through a unit surface area of 1 m<sup>2</sup> per unit time (s) and is referred to as heat flow density ( $q$ ). In its general form, the Fourier equation is:

$$q = -\lambda \cdot \nabla T, \quad (2.1)$$

where  $\lambda$  is a material constant (explained below). The general form in Equation (2.1) can be rewritten for the case of one dimensional and constant temperature gradient as:

$$q = -\lambda \cdot \Delta T / \Delta z, \quad (2.2)$$

where  $\Delta T / \Delta z$  is a constant temperature gradient in vertical ( $z$ ) direction.

On one hand, the planet loses heat due to heat transfer from the interior to the surface. On the other hand, the planet gains some energy by capturing solar radiation. The average global surface heat flow density is about  $65 \times 10^{-3}$  W/m<sup>2</sup> (65 mW/m<sup>2</sup>). The measured surface heat flow density has several contributions. Only a small part, i.e., 30% of it is related to the

Fourier heat flow from core and mantle as described above. The remaining 70% is caused by the heat generated by the decay of radioactive elements in the crust, mostly in the continental “granitic” crust. Specifically, uranium ( $^{238}\text{U}$ ,  $^{235}\text{U}$ ), thorium ( $^{232}\text{Th}$ ) and potassium ( $^{40}\text{K}$ ) in the continental crust produce  $\sim 900 \text{ EJ/a}$  ( $9 \times 10^{20} \text{ J/a}$ ). Together with the contribution of the interior of  $\sim 3 \times 10^{20} \text{ J/a}$ , the planet releases  $1.2 \times 10^{21} \text{ J/a}$  ( $1.2 \text{ ZJ/a}$ ) thermal energy to the space. Most of this thermal energy is restored in the crust continuously. Additionally, the crust is very differently composed, and its thickness differs considerably. Continental crust is typically thick, granitic, and rich in radioactive elements, while oceanic crust is generally thin, basaltic, and poor in radioactive elements [34].

Surface heat flow density  $q$  ( $\text{W/m}^2$ ) composed of the heat flow from the interior and the heat production in the crust varies within a surprisingly narrow range of 40–120  $\text{mW/m}^2$ . The global average of 65  $\text{mW/m}^2$  corresponds to an average temperature increase in the upper part of the Earth’s crust of about 3 °C per 100 m depth increase. Departures from this average value are designated to heat flow anomalies or thermal anomalies. Negative anomalies, smaller than average, are related to old continental shields, deep sedimentary basins, and oceanic crust away from the spreading ridges. Positive anomalies, that are higher than normal gradients, are the prime targets and the major interest of geothermal exploration. Extreme heat flow anomalies are related to volcanic fields and to mid ocean ridges [34].

The estimated total thermal energy above mean surface temperature to a depth of 10 km is  $1.3 \times 10^{27} \text{ J}$ , equivalent to burning  $3 \times 10^{17}$  barrels of oil [35]. Since the global energy consumptions for all types of energy, is equivalent to use of about 100 million barrels of oil per day, the Earth’s energy to a depth of 10 km, could theoretically supply all of mankind’s energy needs for six million years. Therefore, the geothermal energy resources of the planet are truly enormous and omnipresent. However, geothermal energy resources are also characterized by geologic settings, intrinsic properties, and viability for commercial utilization. Therefore, the “geothermal resource base” can be subdivided as shown in [36]. This sub-division is illustrated through a simplified McKelvey diagram (Figure 2.2) in which the degree of geologic assurance regarding resources is set along the horizontal axis and the economic/ technological feasibility (often related to depth) is set along the vertical axis. Both identified and undiscovered systems are considered in this sub-division and following definitions are presented. The “geothermal resource base” represents total available thermal energy in the Earth’s crust beneath a specific area, measured from the local mean annual temperature. The “geothermal resource” is that fraction of the resource base at depths shallow enough to be tapped by drilling at some reasonable future time. Similarly, the “geothermal



reserve” is the identified portion of the resource that can be recovered economically and legally at the present time using existing technology [36].

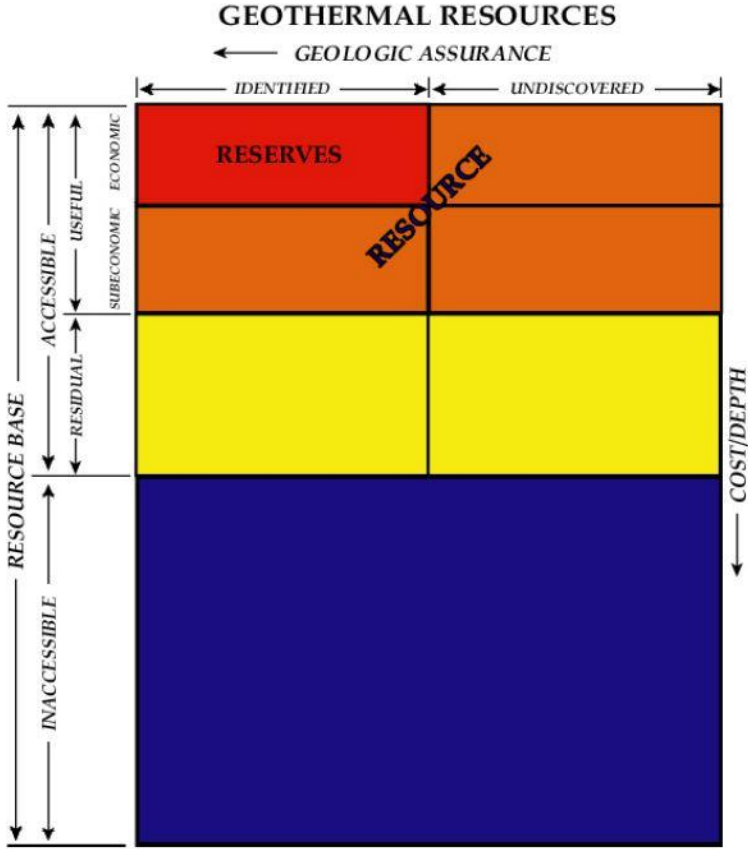

Figure 2.2. McKelvey diagram representing geothermal resource and reserve terminology in the context of geologic assurance and economic viability (source: [36])

2.2.1. Geothermal resource types

Geothermal resources are distributed throughout the Earth’s crust with the largest energy concentration associated with hydrothermal systems in volcanic regions at crustal plate boundaries. However, exploitable geothermal resources are found in most countries worldwide, either as warm groundwater in sedimentary formations or in deep circulation systems in fractured crystalline rocks. Shallow thermal energy exploitable with ground-source heat-pumps is available worldwide. Furthermore, in the last decades attempts are underway at developing enhanced geothermal systems (EGS) in places where limited permeability prevents natural hydrothermal activity.

When talking about geothermal resources definitions and classifications, basic definitions that are commonly used are [37]:

- Geothermal field – is a geographical definition which usually indicates an area of geothermal activity at the earth’s surface or if no surface activity takes place this

term may be used to indicate the area at the surface corresponding to the geothermal reservoir below it.

- Geothermal system – defines the hydrological system as a whole, including recharge zone, and all subsurface parts and the outflow of the system.
- Geothermal reservoir - indicates the hot and permeable part of a geothermal system that may be directly exploited.

Definition and classification of geothermal resources and systems differs and they are classified on the basis of different aspects such as reservoir temperature and enthalpy, physical state, their nature and geological setting [38], or accessibility and discovery status as shown in Figure 2.2. It should be pointed out that the common classification is not to be found in the geothermal literature, even though the one based on the enthalpy is very often used. The classification based on the reservoir temperature, enthalpy and physical state is shown in Table 2.1.

Table 2.1. Classification of geothermal resources based on temperature, enthalpy and physical state (source: [37])

<p><b>Low temperature (LT)</b> - resources with reservoir temperature at 1 km depth below 150°C. Often characterised by hot or boiling springs.</p>	<p><b>Low enthalpy</b> - with reservoir fluid enthalpy less than 800 kJ/kg, corresponding to temperatures less than 190°C</p>	<p><b>Liquid-dominated</b> - reservoirs with the water temperature at, or below, the boiling point at the prevailing pressure and the water phase controls the pressure in the reservoir. Some steam may be present.</p>
<p><b>Medium temperature (MT)</b></p>		<p><b>Two-phase</b> - reservoirs where steam and water co-exist, and the temperature and pressure follow the boiling point curve.</p>
<p><b>High temperature (HT)</b> - resources with reservoir temperature at 1 km depth above 200°C. Characterised by fumaroles, steam vents, mud pools and highly altered ground.</p>	<p><b>High enthalpy</b> - with reservoir fluid enthalpy greater than 800 kJ/kg</p>	<p><b>Vapour-dominated</b> - reservoirs where temperature is at, or above, the boiling point at the prevailing pressure and the steam phase controls the pressure in the reservoir. Some liquid water may be present.</p>

Additionally, the classification based on the geological setting includes classification groups as shown in Table 2.2 [37].

Table 2.2. Classification of geothermal resources based on their nature and geological setting (source: [37])

<b>Volcanic systems</b>	Associated with volcanic activity. The heat sources for such systems are hot intrusions or magma. Permeable fractures and fault zones mostly control the flow of water in volcanic systems.
<b>Fracture-controlled convective systems</b>	The heat source is the hot crust at depth in tectonically active areas, with above average heat-flow. Here the geothermal water has circulated to considerable depth (> 1 km), through mostly vertical fractures, to extract the heat from the rocks.
<b>Sedimentary systems</b>	Produce higher temperature resources than the surrounding formations due to their low thermal conductivity or high heat flow or both, producing temperature gradients >30°C/km. These systems are conductive in nature rather than convective. Some convective systems can however be embedded in sedimentary rocks.
<b>Geo-pressured systems</b>	These systems occur in basin environments where deeply buried fluids contained in permeable sedimentary rocks are warmed in a normal or enhanced geothermal gradient by their great burial depth [35]. The source of energy available from this type of resource consists of: (i) heat, (ii) mechanical energy; and (iii) methane.
<b>Hot dry rock (HDR) or Enhanced Geothermal Systems (EGS)</b>	Are defined as heat stored in rocks within about 10 km of the surface from which energy cannot be economically extracted by natural hot water or steam [35], i.e. they cannot be exploited in a conventional manner. Such systems will mostly be used through production/reinjection doublets. This type of resource is thoroughly described in Section 2.4.
<b>Shallow resources</b>	Near-surface resources of thermal energy to depths of about 150 m (to maximum 400 m) and 20-25°C [34].

### 2.2.2. Heat transport and thermal properties

Thermal energy in the earth, i.e. geothermal heat can be transported by two main mechanisms: (i) by heat conduction through the rock formations and (ii) by a moving fluid, a mechanism referred to as advection. Additionally, these fluids are consisted mostly of water with varying amounts of dissolved salts; typically, in their natural *in situ* state, they are present as a liquid phase but sometimes may consist of a saturated, liquid-vapor mixture or superheated steam vapor phase. Conductive heat flow can be described by the empirical transport equation as  $q = -\lambda \cdot \nabla T$  (Fourier law), expressed in Equation (2.1). It expresses that the heat flux (Watt per unit area of cross section) is caused by a temperature gradient  $\Delta T$  between different parts of a geologic system and that it is proportional to a material property  $\lambda$  called thermal conductivity [W/mK]. Thermal conductivity  $\lambda$  depicts the ability of rocks to transport heat and it varies considerably between various rock types (Table 2.3). Additionally, measured thermal conductivities for the same rock type may vary over wide ranges. That happens due to variations in the modal composition of rocks, different degrees of compaction, cementation or alteration, but also due to anisotropy caused by layering and other structures of the rocks. Crystalline basement rocks such as granites and gneisses conduct heat 2-3 times better than unconsolidated material (e.g. gravel, sand) [34].

For a given temperature gradient, the thermal conductivity ( $\lambda$ ) controls the supply of thermal energy. On the other hand, the heat capacity ( $C$ ) is a parameter of the rock that represents the amount of heat that can be stored in the subsurface. It is the amount of heat  $\Delta Q$  (thermal energy J) that is taken up or given off by a rock upon a temperature change  $\Delta T$  of one Kelvin as shown in Equation (2.3):

$$C = \Delta Q / \Delta T \quad (2.3)$$

Additionally, the specific heat capacity ( $c$ ) of rocks [J/kgK] is the heat capacity per mass unit. It represents the amount of the heat  $\Delta Q$  that is up per mass ( $m$ ) of rock per temperature increase  $\Delta T$ :

$$c = \Delta Q / (m \cdot \Delta T) \quad (2.4)$$

The thermal conductivity and heat capacity depend on pressure and temperature. Both parameters decrease with lower depths in the crust. Consequently, for a specific material the temperature rises as bigger depth is reached.

Table 2.3. Thermal conductivity and specific heat capacity of various materials (rocks and fluids) for 25 °C and 1 bar conditions (source: [34])

Rocks/fluids	Thermal conductivity $\lambda$ [WmK]	Specific heat capacity [kJ/kgK]
Gravel, dry sand	0.3 – 0.8	0.50 – 0.59
Gravel, wet sand	1.7 – 5.0	0.85 – 1.90
Clay	0.9 – 2.3	0.80 – 2.30
Limestone	2.5 – 4.0	0.80 – 1.00
Dolomite	1.6 – 5.5	0.92 – 1.06
Marble	1.6 – 4.0	0.86 – 0.92
Sandstone	1.3 – 5.1	0.82 – 1.00
Shale	0.6 – 0.4	0.82 – 1.18
Granite	2.1 – 4.1	0.75 – 1.22
Gneiss	1.9 – 4.0	0.75 – 0.9
Basalt	1.3 – 2.3	0.72 – 1.00
Quartzite	3.6 – 6.6	0.78 – 0.92
Rocksalt	5.4	0.84
Air	0.02	1.0054
Water	0.59	4.12

The heat flow density ( $q$ ) and thermal conductivity ( $\lambda$ ) reflect the temperature distribution at a depth. The temperature gradient is the temperature increase per depth increment (grad  $T$  or  $\Delta T$ ) at a specified depth. Equation (2.5) shows that  $T$  at a given depth (for constant one-dimensional gradients) is determined by the heat flow density and the thermal conductivity:

$$\Delta T / \Delta z = q / \lambda \quad (2.5)$$

Temperature gradients, heat flow density and hence the temperature distribution in the subsurface is not uniform. If the deviation from average values is significant, the features are called positive or negative temperature (thermal) anomalies. There are numerous geologic

causes of positive thermal anomalies including active volcanism and upwelling hot deep waters in hydrothermal systems. Therefore, traditionally, positive anomalies areas are prime targets for geothermal projects due to fact that their exploration and development require smaller drilling depth.

### 2.2.3. Permeability and porosity

Permeability and porosity are most significant physical properties of the reservoir rock.

The permeability of continental crust is defined by the capacity of the geological medium (rock) to transmit fluid. It represents a critical geological parameter for the definition of geothermal reservoir because it influences both the heat and the mass transfer.

Porosity is a measure of the void spaces in a material, i.e., rock structure. In other words, it is the ratio of pore volume to the total volume of the rock. Sedimentary rocks such as limestone, sandstone, or conglomerate are generally porous and can store large quantities of fluids within their pore network. They constitute natural reservoirs in the crust for all kind of fluids.

A schematic in Figure 2.3 shows the difference between permeability and porosity features of the rock.

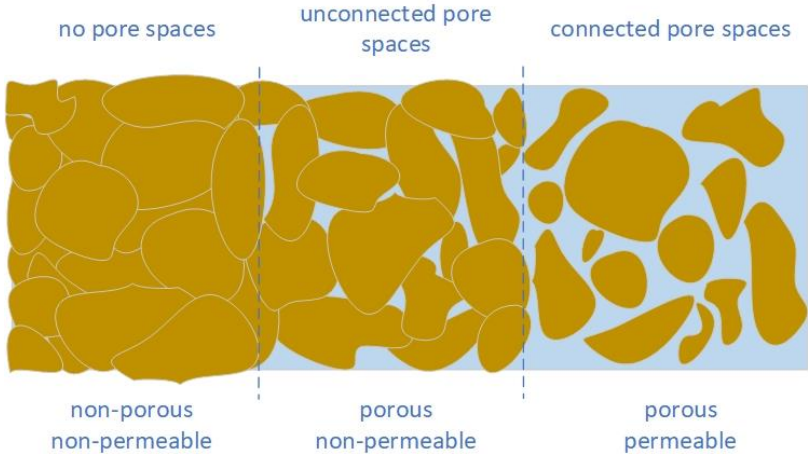

Figure 2.3. Different degrees of permeability and porosity of rocks

When talking about fractured reservoirs, either natural or stimulated, dual permeability and porosity models are often used because they present complex and multi-scale systems composed of matrix and fractures. Namely, in fractured rocks there is a presence of dual entities, i.e., the network of fractures or cracks and the unfractured background. Typically, porosity and permeability are separately defined for fractures and matrix continuum, giving rise to the so-called dual porosity/dual permeability models. In the most general formulation,

both media have nonzero porosity and permeability and fluids can flow between the fracture systems and the matrix as well as between adjacent blocks of the unfractured rock [39].

The fracture permeability is linked to the discontinuities that are present within the rock along which fluid circulation is possible. This type of permeability is generally well developed in crystalline massifs. The geomechanical and reservoir properties of both fractures and rock matrix can vary widely, and one must recognize and account for these properties on a case-by-case basis. In general, enhancement of permeability is usually attributed to the fracture networks while the matrix is associated with storage capacity. Figure 2.4 shows the comparison between matrix permeability and fracture permeability for natural shale core depending on the pore diameter and fracture aperture [40].

Fracture porosity contributes only a few percent to the total porosity.

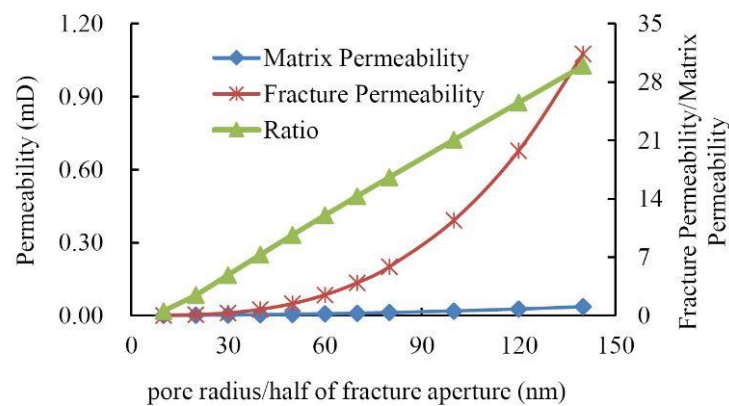

Figure 2.4. A comparison between matrix and fracture permeability for natural shale core (source: [40])

### 2.3. APPLICATIONS OF GEOTHERMAL ENERGY

Geothermal energy, as a heat from the interior of the Earth, has been utilized by mankind from the early stages of its existence. Hot springs and hot pools have been used for bathing and health treatment, but also for cooking or heating. The resource has also been used for producing salts from hot brines. Nowadays, apart from utilization of ‘hot water’, i.e., geothermal energy in balneological and agricultural purposes, it is used for space cooling and heating purposes, and in many industrial processes.

Utilization of thermal water for energy conversion started in the second half of the 19<sup>th</sup> century which was in high correlation with rapid developments in the field of thermodynamics. Knowledges in thermodynamics supported efficient conversion of energy from hot steam, first in mechanical energy and then into electrical energy with the help of turbines and generators. The first installed geothermal power plant in the world was the Larderello plant which went into operation in 1913 with installed capacity of 250 kW. In 2015

the power plant capacity was increased to 15 MW and was driven by saturated steam. The installed capacity of the Larderello power plant was increased gradually through the years and nowadays it is formed of 34 power plants with total installed capacity of 800 MW [41].

Generally, exploitation of geothermal energy can be divided in two main groups: deep geothermal systems exploitation; and shallow geothermal systems exploitation (Figure 2.5).

Shallow geothermal systems extract the thermal energy (heat) from the uppermost layer of the earth crust. Commonly, a depth of about 150 m is of interest which may extend to a maximum 400 m. Typical systems include: ground heat collectors, borehole heat exchangers, boreholes into groundwater, and geothermal energy piles [34]. The exploitation is indirect and requires conversion with e.g., heat pumps.

Deep geothermal system methods are employed at depth of 400 m and below. However, deep geothermal low-enthalpy systems in the proper and real sense are those at depth more than 1,000 m and temperatures above 60 °C. However, one needs to keep in mind that in high-enthalpy fields high temperature fluids can be produced from boreholes in the range of hundreds of meters rather than thousands of meters as in the low-enthalpy deep geothermal fields [34]. Deep geothermal energy systems exploit geothermal energy by means of deep boreholes, and for some direct usages, the extracted heat can be used directly without further transformation.

Deep geothermal energy utilization is of interest in the scope of this thesis. Therefore, the applications of deep geothermal energy are explained in the next Sub-sections and for shallow geothermal energy the reader is advised to consider other sources.

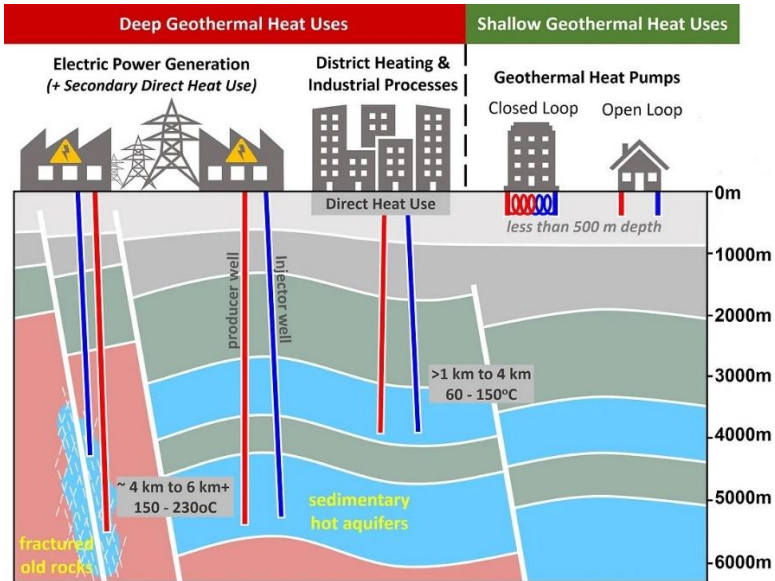

Figure 2.5. General classification of geothermal energy usages - deep geothermal energy utilization and shallow geothermal energy utilization (source: [42])

There are two major ways of geothermal energy utilization: direct utilization, and indirect utilization (Table 2.4).

Table 2.4. Two major ways of geothermal energy utilization

Direct utilization	Indirect utilization
Aquaculture (fish farming and raceway heating)	Space heating and cooling (including district heating systems)
Agriculture (greenhouse heating, crop drying, heating of buildings housing livestock)	Electricity generation
Balneology (tourism, health)	Industrial purposes (e.g., mineral extraction)

Generally, the temperatures of a geothermal fluid required for direct utilization applications are lower than those for economic electricity generation. However, there have been advances in electricity generation from low-temperature (>70°C) geothermal sources, but this application is yet to be commercially proven and established. The ranges of geothermal fluid temperatures for different utilization options are shown in modified Lindal diagram (Figure 2.6).

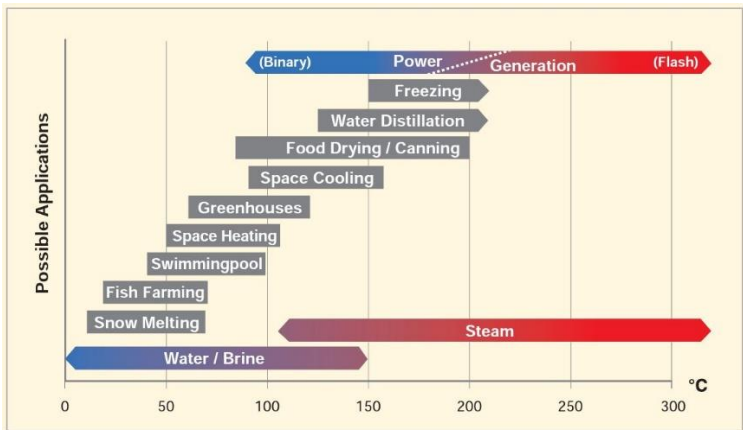

Figure 2.6. The modified Lindal diagram for geothermal energy applications (source: [43])

### 2.3.1. Direct usage

Balneological application of geothermal energy is one of the main uses for centuries. In countries like China, Iceland, Japan, New Zealand, North America, Turkey and other areas geothermal water has been used for bathing and cooking purpose for over 1,000 of years. The Romans believed that geothermal water has therapeutic effect and used it therefore for treatments of many health conditions. The largest reported annual energy uses for bathing and swimming are from China, Japan, Turkey, Brazil, and Mexico. Additionally, 53 countries are using geothermal energy for bathing and swimming purposes [44].

Greenhouse heating is nowadays one of the most common direct applications of geothermal energy utilization which basically is used to maintain the climate (predominantly



humidity and temperature) necessary for growing different vegetables and other plants. Depending upon the heating demand of greenhouses the temperature of water supplied ranges from 40 - 100 (115) °C. The water is spread by the means of steel pipes which are placed under the soil, on the soil or on benches, between the plant rows or suspended in the greenhouse space. All over the world more than 1,000 glasshouses and soft plastic covered greenhouses use geothermal energy as the heat source [45]. In 2020, a total of 32 countries used greenhouse heating, with the leading countries in annual energy use (TJ/year) being Turkey, China, Netherlands, Russia and Hungary, accounting for about 83% of the world's total [44].

Under agricultural drying applications the geothermal energy has been used to dry vegetables, fruits crops and other cereals. Fifteen countries use geothermal energy for agricultural drying [44] among which China, France, Hungary and United States are the largest users.

Space and district heating are among the most successful geothermal direct applications in countries with cold climate and available geothermal resources. Geothermal space heating, including individual heating and district heating is used in 29 countries worldwide. The leaders in district heating in terms of both capacity and annual energy use are China, Iceland, Turkey, France and Germany, whereas in the individual space heating sector in installed capacity ( $MW_{th}$ ) the leaders are Turkey, Russia, Japan, United States, and Hungary [44]. For space heating the open loop or closed loop systems can be used. In open loop, which is a single pipe system, the geothermal water is used directly, and the used water is reinjected or discharged to waste. In closed loop, which is a double pipe system, the heat exchangers are commonly used. Namely, the heat from the geothermal brine is transferred in the heat exchanger to the secondary fluid which is then used for space/district heating. Preferred inlet water temperatures are in the range between 60 - 90 °C, and common outlet (return) water temperatures are 25 - 40 °C. Furthermore, the population density and distance between the geothermal field and the market (heat demand centres) is important for the economy of the system.

Industrial uses of geothermal energy include drying (e.g., wood), process heating (preheating of boiler water), distillation, chemical extraction, CO<sub>2</sub> production, etc. These operations tend to be large and have high energy consumption, often operating year-round. Industrial applications tend to have high load factors (0.4 – 0.7) which reduces the unit cost of energy. In total 14 countries the geothermal energy is applied for these purposes [44].

### 2.3.2. Electricity generation

Electrical power can be produced with high efficiency directly from steam turbines where steam is produced from high enthalpy reservoirs (in high enthalpy geothermal fields). High brine temperatures of more than 200 °C are required for the necessary steam pressure using water as heat transfer material. Producing electrical power from low enthalpy reservoirs is only possible with heat transfer substances with higher vapor pressure. In other words, in such conditions the binary cycle power plants are used for electricity generation. Organic Rankine Cycle (ORC) plants use e.g., pentane and Kalina cycle plants ammonia-water mixtures as heat transfer substances. The electrical efficiency of such plants varies between 10 and 15% depending on transfer material and operating temperature. The electricity generation form closed binary-loop low-enthalpy systems, such as ORC or Kalina, is a relatively new technology which is being developed and installed in R&D projects all around the world in the last decades.

Organic Rankine Cycle plants work with an organic fluid which has a relatively low boiling temperature. The vapor phase of this fluid passes through a turbine, thereby driving a generator which consequently generates electricity. Kalina installations use an ammonia-water mixture as a heat transfer fluid. The non-isothermal boiling of two-component fluid is a characteristic process of fluid mixtures. On the other hand, steam power plants require a superheated steam at turbine inlet in order to avoid the risk of having a too low steam quality in last expansion stages. On the contrary, the organic fluids remain superheated at turbine outlet due to a positive slope of saturated vapor curve; therefore, for ORC plants the superheating is not strictly necessary. When compared to conventional steam power plants, ORC systems are in general easier to manage. Furthermore, for small size plants, in addition to a higher efficiency in exploiting medium-low heat sources, ORCs are more competitive compared to conventional steam cycles.

Today, with nearly 15 GW of installed capacity of geothermal power plants, there are several energy conversion technologies commercially available at various stages of maturity. Geothermal power plants can be categorized in three main groups depending on the fluid temperature, pressures, and chemistry:

- Condensing power plants (dry steam, single or double flash systems);
- Back-pressure turbines; and
- Binary cycle power plants.

Dry steam power plants (Figure 2.7) were the first type of geothermal power plants built and put in commercial operation. They use the steam from the vapour-dominated geothermal reservoir coming from the production well. The steam is brought directly to the turbine where it expands and consequently steers the generator which produces electricity. The condenser can either be a direct-contact or surface type (shell-and-tube). Dry-steam geothermal plants have very low potential impact on the environment. The geofluid consists of only steam so there is no mineral-laden brine to dispose of.

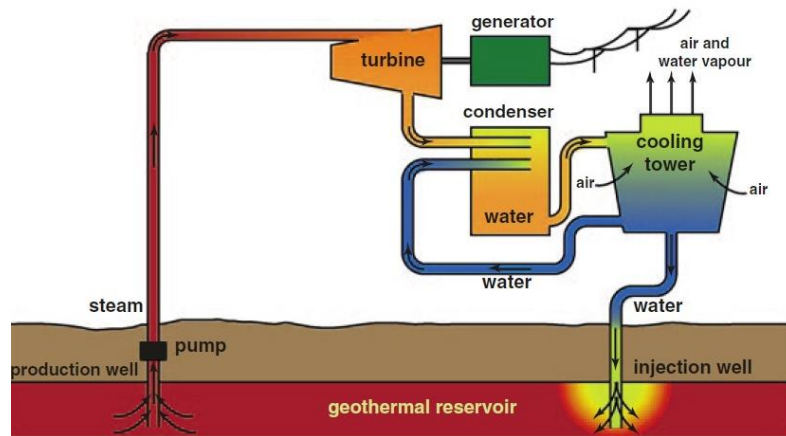

Figure 2.7. Dry steam geothermal power plant (source: [34])

Flash steam power plants (Figure 2.8 shows single flash power plant) are the most common type of geothermal power plants, especially single flash power plants. The steam is separated from the water in the separator, and directed through the pipes to the turbine where it gets expanded. This drives the generator, and the electricity is produced. The steam is condensed after the turbine, creating a partial vacuum, and thereby maximizing the power generated by the turbine-generator unit. The steam is usually condensed either in a direct contact with the condenser, or a heat exchanger type condenser. In a direct contact condenser, the cooling water from the cooling tower is sprayed onto and mixes with the steam. The condensed steam then forms part of the cooling water circuit, and a substantial portion is subsequently evaporated and dispersed into the atmosphere through the cooling tower. Excess cooling water, called blow down, is often disposed of in shallow injection wells. As an alternative to direct contact condensers shell and tube type condensers are sometimes used. In this type of plant, the condensed steam does not come into contact with the cooling water and is disposed of in injection wells [46]. The double-flash steam power plant is an improvement on the single-flash design that can produce 15 - 20% more power output, compared to single-flash, for the same geothermal fluid conditions [47]. The power plant is more complex, more costly, and requires more maintenance, but the extra power output often justifies the installation of

such design. In double flash power plant, the separated steam is expanded in high- and then in low-pressure turbine. The rest of the process is the same as described above.

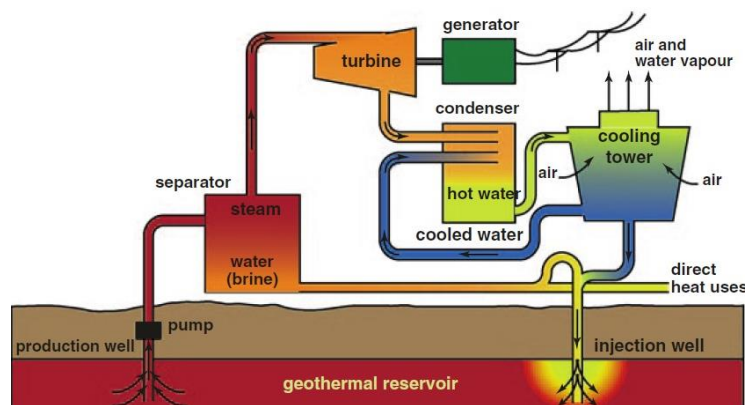

Figure 2.8. Single flash steam geothermal power plant (source: [34])

To produce electricity from low-enthalpy resources with geothermal brine temperatures between 90 – 150 °C (with significant efforts lately to produce electricity even from 60 – 70 °C) the binary cycle power plants are used (Figure 2.9). Namely, the lower the resource temperature the worse the problem becomes for flash technology. At such low temperatures it is unlikely that the wells will flow spontaneously, and if they do, there is a strong likelihood of calcium carbonate scaling in the wells. Binary cycle geothermal power plants are the closest in thermodynamic principle to conventional fossil or nuclear plants in that the working fluid undergoes an actual closed cycle. The working fluid (secondary loop), chosen for its appropriate thermodynamic properties, receives heat from the geothermal fluid (primary loop) coming from production well(s) into the heat exchanger, evaporates, expands in turbine, condenses, and is returned to the evaporator by means of a feed pump. The working fluid must be selected based on constraints related the thermodynamic properties of the fluid as well as considerations of health, safety, and environmental impact. The geothermal fluid is everywhere kept at the pressure above its flash point to prevent the breakout of steam and non-condensable gases that could lead to calcite scaling in the piping. Additionally, the geothermal fluid temperature must not drop to the point where silica scaling could become an issue in the piping and injection wells. The condenser is either water cooling tower or air-cooling condenser. The geothermal fluid is reinjected back into the reservoir through injection well(s).

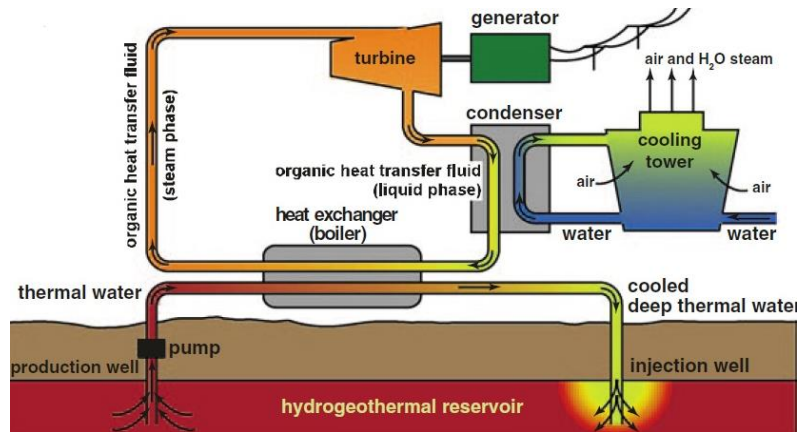

Figure 2.9. Binary cycle geothermal power plant (source: [34])

### 2.3.3. Combined heat and power production (CHP)

Combined heat and power (CHP) power plants increase the net efficiency by combining the direct usage of heat and electricity generation, which in turn improves the power plant economics. Due to lower working fluid temperatures in geothermal power plants, this becomes an interesting option since it can increase the low thermodynamic efficiency of the energy conversion process. Due to the high drilling costs of deep-geothermal power plants (up to 70% of the investment costs), the overall plant efficiency, and hence the plant economics, might be increased by the combined production of electricity and useful heat.

Two main configurations of CHP geothermal power plant can be defined, series (Figure 2.10 (a)) and parallel configuration (Figure 2.10 (b)), respectively.

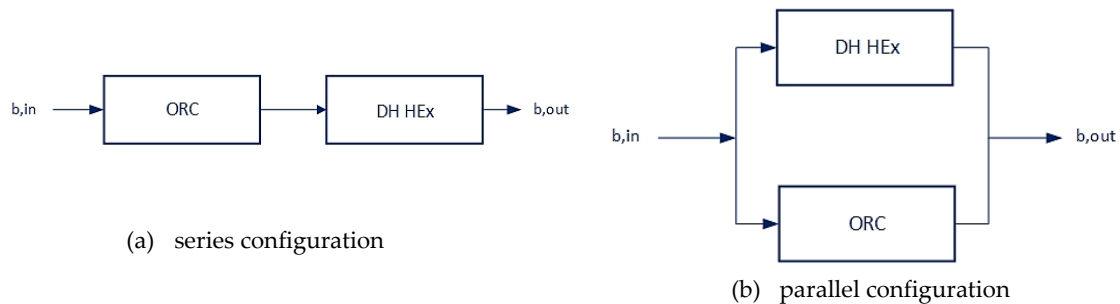

Figure 2.10. Series (a) and parallel (b) CHP configurations

In the series configuration, the high temperature geothermal brine ( $b,in$  in the Figure 2.10) coming from the production well(s) delivers heat first to the binary power plant (e.g. ORC unit) and subsequently to the direct usage unit (e.g. district heating (DH) heat exchanger (Hex) as depicted in Figure 2.10) at lower temperature. Afterward, it is reinjected ( $b,out$  in the Figure 2.10) into the reservoir through the injection well(s).

In parallel configuration, heat is delivered to both direct usage unit and binary power plant at high temperature ( $b,in$  in the Figure 2.10), however, at different flow rates. Namely, the

total geothermal brine flow is firstly divided into two branches for each end usage (heat production and electricity generation) and after the heat has been transferred the geothermal brines at lower temperatures from the two branches mixes (*b,out* in the Figure 2.10) and is reinjected into the reservoir via injection well(s).

Whether the parallel or the series configuration is the most appropriate depends on the temperature levels of the direct usage system. In general, the parallel configuration has the best performance for high direct usage temperatures, whereas the series configuration performs better for low direct usage temperatures [48].

## 2.4. DEFINING ENHANCED GEOTHERMAL SYSTEMS (EGS)

Geothermal energy is a ubiquitous renewable energy source. However, currently only a small fraction of geothermal potential is used for electricity generation, or to provide heat for commercial, industrial, and residential sectors. Namely, huge potential is present at high depths, i.e., in deep geothermal systems, whose development is associated with high technical and economic risks at the exploration stage as much as large upfront costs related to well-drilling and potential reservoir stimulation.

Existing technology for exploiting the geothermal capacity is commercially applicable for exploitation of conventional systems, i.e., hydrothermal systems. In contrast to these technologies, the systems that require technical enhancement through hydraulic, thermal, or chemical stimulation methods or advanced well configurations, are lately defined as enhanced geothermal systems (EGS). This definition is not related only to low permeability conductive petrothermal systems, but also to low productivity convective hydrothermal systems that require technical enhancement in order to increase the productivity of the system [1].

The EGS concept consists of creating a fracture system in the targeted geological formation used for the injected geothermal fluid circulation. Namely, the EGS facility cycle requires continuous water injection through injection well. The fluid then circulates through created pathways where it is heated and then brought back to the surface using a second, production well. At the surface, the heat is extracted in the binary cycle to generate electricity or is used for direct heat applications.

The comparison between conventional hydrothermal systems and enhanced geothermal systems is shown in Figure 2.11. Namely, electricity generation has conventionally been associated with the search of large reserves of hydrothermal resources. Hydrothermal resources present the reservoirs containing fluids which can be extracted and used for

conversion of geothermal energy into electricity (and/or heat). Such reservoirs must firstly be located (often such resources are accompanied by surface manifestations such as hot springs, mud pots, etc.), and examined to determine whether they contain sufficient fluid for the operational phase to be viable. In this regard, such geothermal resources are similar to the oil reserves exploitation, because the reservoir can only be exploited until there is sufficient geothermal fluid contained in it, i.e., a limited period of time. Furthermore, five features are essential to establish a commercially viable hydrothermal geothermal resource [47]:

- A large enough heat source;
- A permeable reservoir;
- A supply of water;
- An overlying layer of impervious rock; and
- A reliable recharge mechanism.

If any one of the five above listed features is lacking, the geothermal field will generally not be worth exploiting. Namely, without a large heat source, temperatures of geothermal fluid will be relatively low, i.e., the thermal energy of the system will be insufficient to support exploitation long enough to make it economic. Without sufficient permeability in the formation, the fluid will not be able to move readily through it, that is, it will not be able to remove much of the stored thermal energy in the rock. Moreover, low permeability will cause poor well flow or may prevent any production from the reservoir. Without fluid in the system there is no heat transfer medium, and the thermal energy of the rock formation will remain in the reservoir. Without an impermeable cap rock, the geofluids will easily escape to the surface appearing as numerous thermal manifestations and the pressure in the formation will quickly dissipate. And lastly, without a reliable and adequate recharge to the reservoir, the geofluid will eventually become depleted when it supplies a power plant.

In cases where the large heat source exists but there is insufficient or no fluid to act as a heat transfer medium, or the permeability is not sufficient to support commercial development of the resource the reservoir can be created and ‘enhanced’ by different stimulation techniques and in that way the EGS is developed. Such systems then enable exploitation of non-hydrothermal resources. Namely, an injection well is drilled into the hot formation to a depth corresponding to the promising zone. Cold water is injected under high pressure to open existing fractures or create new ones (Figure 2.11). Once the formation reaches a state of sufficient volume and permeability, another well (or wells) is (are) drilled to intercept the newly formed ‘reservoir’. Ideally, a closed loop is thus created whereby cold water is pumped

down the injection well and returned to the surface through the production well after passing through the hot, artificially fractured formation [47].

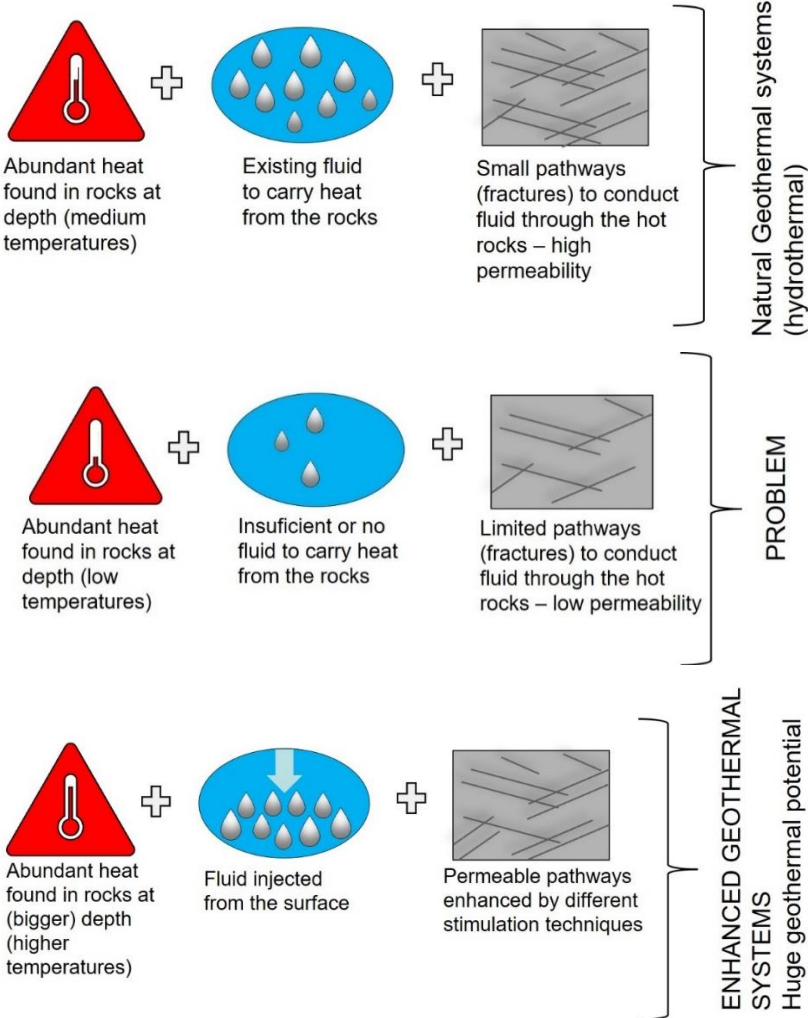

Figure 2.11. Comparison of conventional hydrothermal systems and enhanced geothermal systems

Even though there is a significant increase of interest for geothermal energy exploitation and utilization, and research and development of EGS projects, the EGS technology is not yet mature enough to be commercially competitive with other renewable resources such as wind and solar. As stated in [49] the most compelling achievements would be the demonstration of a functional petrothermal EGS plant with the successful formation of a large fractured heat exchanger at depth and possible demonstration of new drilling technology that would permit significant reductions in drilling costs. Other expected actions include performance improvements in exploration, downhole instrumentation, geotechnical computation and simulation and incremental cost reductions in many areas [49].



### 2.4.1. EGS potential

Whenever there is a need to quantitatively express the amount of not yet developed geothermal energy, the word “potential” can be used. Considering renewable energy, it is customary to refer to different potential categories. According to [50] there is a clear distinction between five categories of potential (Figure 2.12). The *theoretical potential* describes the physically usable energy supply (for geothermal: heat in place). Due to technical, structural, and administrative limitations only small fraction of the theoretical potential can actually be used. This fraction of theoretical potential that can be used with currently available technologies is called *technical potential*. Since this potential depends mainly on technical boundary conditions it is less subject to temporal variations than the economic potential. The *economic potential* describes the time and location dependent fraction of the technical potential that can be economically utilized within the considered energy system. Several economic boundary conditions exist, e.g., oil price change, changing taxations, feed-in-tariffs, etc. The *sustainable potential* is a fraction of the economic potential. It describes the fraction that can be utilised by applying sustainable production levels. The *developable potential* describes the fraction of the sustainable potential that can be developed under realistic conditions (regulations, environmental restrictions). These categories of geothermal potential have been used to create the protocol for estimating and mapping the EGS potential [51].

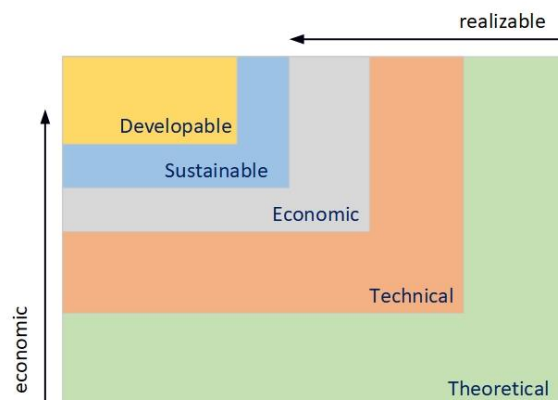

Figure 2.12. Potential definition for renewable energy including geothermal energy (modified after [50])

Using the protocol [51], the global estimate of enhanced geothermal systems potential has been made in [13]. Theoretical, technical, optimal economic, and sustainable potential of EGS has been demonstrated. To evaluate this EGS potential the world was clustered into a regular gridding interval of 1 degree by 1 degree. Once the input data are gathered, the temperature at depth maps are constructed. Then, the available heat for each depth interval in each gridded

cell are computed. Next, the theoretical and technical EGS potentials are estimated. Finally, the optimum depth is identified, and the respective optimal potential based on the given data is obtained. The optimum depth is determined by finding the first cell at each depth interval with temperature  $\geq 150^{\circ}\text{C}$  (intervals of  $50^{\circ}\text{C}$ ). Ultimately, there is a minimum LCOE at which all the EGS components are at their optimal points. In the most optimistic scenario and without considering any constraints, such as cost and water stress, the global exploitable EGS potential is found to be about  $200 \text{ TW}_e$ , or  $480 \times 10^6 \text{ TWh}_{th}$ . The global optimal economic EGS potential in terms of power capacity is found to be around 6 and  $108 \text{ TW}_e$  for the cost years 2030 and 2050, respectively. The sustainable potential of EGS is approximately  $256 \text{ GW}_e$  in 2050, accounting for just 0.2% of the technical potential globally.

As an extension of the protocol [51], an approach for resources assessment of Europe was provided in [14]. The resource base for EGS in Europe was quantified and economically constrained, applying a discounted cash-flow model to different techno-economic scenarios for future EGS in 2020, 2030, and 2050. From theoretical capacity which presents the amount of thermal energy physically present in the reservoir rocks of a certain area, the theoretical potential is calculated. This potential describes the amount of capacity that can be converted from theoretical capacity within the economic lifetime using a conversion efficiency. The part of the theoretical potential that can be exploited with currently available technology using a recovery factor is called technical potential. The economic potential describes the part of the technical potential that can be commercially exploited for a range of economic conditions. First the subsurface temperature model of onshore Europe was constructed. With the modelled subsurface temperatures and future technical and economic scenarios, the technical potential and minimum levelized cost of energy (LCOE) are calculated for each grid cell of the temperature model. Cutoff values of  $200 \text{ €/MWh}$  in 2020,  $150 \text{ €/MWh}$  in 2030, and  $100 \text{ €/MWh}$  in 2050 are imposed to the calculated LCOE values in each grid cell to limit the technical potential, resulting in an economic potential for Europe of  $19 \text{ GW}_e$  in 2020,  $22 \text{ GW}_e$  in 2030, and  $522 \text{ GW}_e$  in 2050 [14].

Another assessment of EGS potential in Europe is provided in [15]. Namely, estimation and comparison of the technical and sustainable potentials of EGS in Europe as a whole and in each one of the considered countries were carried out for the depth between 3 km and 10 km, as it is reasonable to consider that the temperatures above  $150^{\circ}\text{C}$  at depths less than 3 km are not likely to be found. The EGS technical potential for Europe is as high as  $6,560 \text{ GW}_e$ ; and the EGS sustainable potential for Europe is as high as  $35 \text{ GW}_e$ .

## 2.4.2. Development of an EGS power plant

There are three main phases of a development of an EGS power plant and those include: finding the suitable site; creating the reservoir; and operating the reservoir. Each of the phases presents unique challenge for the developers and with increase of the maturity of this technology and transfer of the knowledge from oil and gas industry these challenges could be successfully overpassed in time.

### 2.4.2.1. *Finding a site*

First step for any geothermal project is the exploration phase in which a suitable site is determined. However, the lack of experiment in developing EGS power plants presents an ongoing problem in determining what ‘suitable’ exactly means. The suitability assessment must either be based on the knowledge of the site and its surroundings, i.e., on existing databases, or on developed preliminary geological, geochemical, and numerical studies in case of lack of the databases. The depth to which the wells must be drilled is a fundamental point for financial reasons [52].

The next step is to drill the exploratory well to measure and/or confirm properties of the reservoir *a priori*. This well, however, may not necessarily form a part of the EGS reservoir later. It is essential to drill to the centre of the rock considered for the potential reservoir so that data can be obtained on its physical and chemical properties. Small fractures are then created by hydraulic fracking to determine the surface tension on the spot. These tests must also be done to determine the fluid that can flow through the rock so that the estimates of its permeability and the potential productivity of the reservoir can be drawn up.

### 2.4.2.2. *Creating a reservoir*

Once the preliminary characterisation of the reservoir has been completed, the developing of initial injection well can start. This initial injection well will be used to stimulate the reservoir bedrock. The basic purpose of the stimulation process is to create the pathways required for fluid to flow efficiently from the injection well(s) to the production well(s). These pathways need to allow fluid to pass through at the lowest possible pressure to facilitate the operation of the reservoir and save costs.

Different stimulation concepts have been applied to enhance the productivity of geothermal reservoir. Three main stimulation techniques are: chemical; thermal; and hydraulic stimulation. The hydraulic stimulation has the potential to improve the field up to several hundreds of meters away from the borehole (well), whereas the chemical and thermal

stimulation techniques improve the near-wellbore region up to a distance of a few tens of meters. Additionally, the procedures of hydraulic fracture stimulations are well known in the hydrocarbon industry. However, the application for geothermal reservoirs requires a technique that is able to produce considerable higher amounts of fluids than the ones required for production of hydrocarbon reservoirs [53].

Once the initial volume of the rock has been stimulated by creating the new fractures and/or enlarging the old fractures, a production well can be drilled to begin the circulation of the fluid. The production well must be drilled at the right distance from the injection well to prevent the premature prolongation of colder front from the injection reservoir which could lead to the overall decrease in reservoir productivity. Drilled well(s) can be vertical, directional, or horizontal. The vertical and directional drilling are the key technologies for the exploration and exploitation geothermal resources in deep formations. Wells which aim at a target directly below its surface location are considered to be vertical wells. Directional drilling is the process of drilling a well which is to follow a prescribed traverse and intersect a specific objective. The objective is called a target and is usually an enclosed area in a horizontal plane, the target also could be a circular area at the top of a producing zone [54]. Horizontal and high-angle drilling operations generally are similar to the directional drilling but more complex due to higher build rates and drift angles, longer tangent and horizontal sections. Horizontal drilling is the process of drilling a well from the surface to a subsurface location just above the target geothermal reservoir.

#### *2.4.2.3. Operating the reservoir*

When operating an EGS reservoir, the object is to maintain the hot fluid output ratio throughout the useful lifetime for which the plant is designed. Following challenges of sustainable EGS plant and reservoir operation must be ensured during the lifetime of the project: heat extraction must be optimised; a suitable production rate must be maintained; fluid loss must be prevented; and losses in heat and/or electricity production must be minimised. All these parameters must be monitored and managed accordingly for a successful management of an EGS reservoir and power plant.

The reservoir can be exploited using various production systems: doublet system, multi-well system or even deep borehole heat exchanger (DBHE). Doublet systems consists of production and reinjection well and is simpler and cheaper compared to multi-well system. However, multi-well system provides more flexibility in creation of network of several reinjection and production wells which can reduce the pressure and minimize the seismic

hazard that may arise from the exploitation of geothermal reservoir (very important aspect of EGS projects, especially from societal point of view). DBHE are generally coaxial pipes installed in deep boreholes and has become an alternative approach to utilize geothermal energy. The principle of DBHE is to install a coaxial pipe into a deep borehole to inject cold water into the outer pipe and extract hot water from the inner pipe, forming a closed-loop system [55].

2.4.3. EGS projects worldwide

Despite the fact that EGS technology has been developed over the past 40 years in several countries [2], [3], almost all 18 significant EGS power plants reviewed in [3], need(ed) to be jointly founded by governments and/or other state related entities. In other words, a growing interest in the applications of the enhanced geothermal systems and medium-to-low temperature geothermal resources can be observed in the last decades with an increased attention dedicated to the possibilities of developing EGS in last five years, especially in countries like USA, Iceland, Britain, Germany, China, Portugal, and the Netherlands [4], but often a reference frame in this field does not exist. The barriers and challenges for establishing EGS utilization plans are described in more detail in the next Section 2.4.4.

In [56] a systematic review of past and present EGS projects has been done. In total 31 EGS project were classified by country, reservoir type, depth, reservoir, wellhead temperature, stimulation methods, induced seismicity and radioactivity, plant capacity, flow rate, and current status. This review presents the exhaustive information about EGS projects that are: (i) still under development (R&D and commercial) and not generating electricity; (ii) ongoing EGS projects (R&D and commercial) generating electricity; (iii) concluded experimental EGS projects (without electricity generation); and (iv) abandoned or on hold EGS projects due to various issues. The Table 2.5 shows above-mentioned categories of reviewed EGS projects in terms of number of projects under each category.

Table 2.5. EGS projects worldwide (summarized according to [56])

<b>Category of EGS projects</b>	<b>Number of projects</b>
Still under development (R&D and commercial) and not generating electricity	8
Ongoing EGS projects (R&D and commercial) generating electricity	14
Concluded experimental EGS projects (without electricity generation)	6
Abandoned or on hold EGS projects due to various problems	3

The first EGS project in the world was Fenton Hill in the United States, where the first experiments started in 1973. The Fenton Hill project was developed by Los Alamos National

Laboratory (LANL). The task included the creation of a reservoir in granite with a temperature of 300 °C at a depth of 4.4 km and the testing of a 60kWe binary cycle power generation system that operated at low and medium temperatures. However, the project was terminated due to the inability to reach the expected capacity [3].

The EGS project in Soultz-sous-Forêts in France was the first operating commercial-scale EGS power plant in the world. The project started in 1989 and had three R&D research phases. Since more than 25 years, scientists from universities and industry spent their effort at Soultz-sous-Forêts to build the first EGS power plant, which came into commercial operation in 2009 [57]. Important outcome of the Soultz EGS project, which is an artificially fractured reservoir, is successful operation as a commercial-scale geothermal power plant. The site characteristics, such as the natural fissures and their connectivity, are the primary driving factors for the success of this EGS project.

As illustrated in Figure 2.13 most of the European EGS projects' reservoir temperatures (bottomhole temperature) are lower than 165°C (with exception of Lardarello and Bouillante). The average reservoir temperatures of EGS projects in America, Australia and Asia are higher compared to the European ones, although the well depths are comparable. Only 25 projects are listed in Figure 2.13, because the remaining 6 projects (St. Gallen, Fjällbacka, Falkenberg, The Southeast Geysers, Basel and Bad Urach) have no publicly available data regarding reservoir temperatures. Furthermore, the relationship shown in Figure 2.14 demonstrates that most EGS projects are operated at brine flow rates lower than 40 l/s. Only 20 projects are displayed in Figure 2.14, other 11 projects (Genesys Hannover, Insheim, Mauerstetten, Newberry, Coso, Berlín, Falkenberg, The Southeast Geysers, Basel, Bad Urach and St. Gallen) are excluded because of the lack of the publicly available data on brine flow rates.

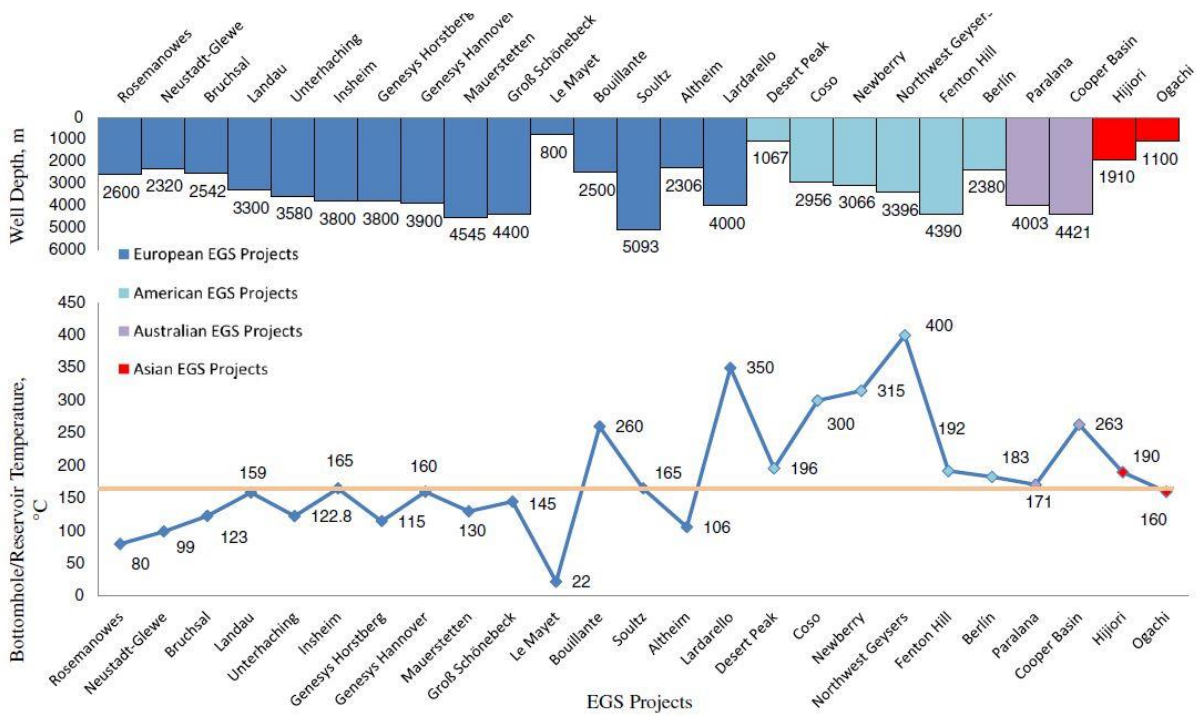

Figure 2.13. Worldwide EGS projects' reservoir temperature and depth (source: [56])

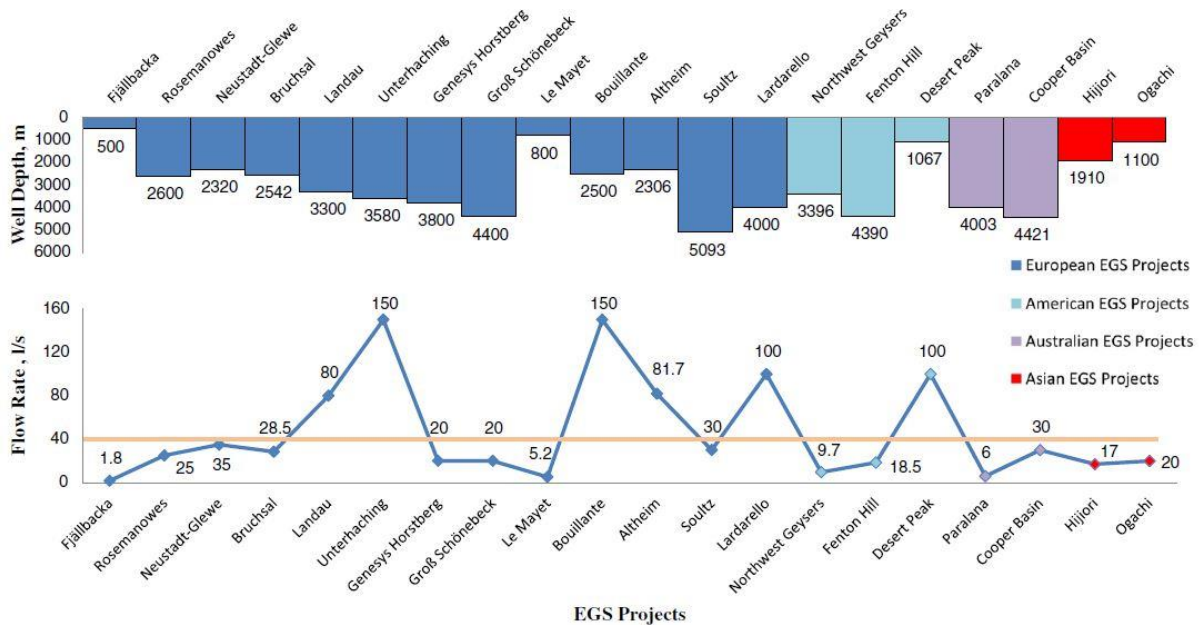

Figure 2.14. Worldwide EGS projects' flow rate and depth (source: [56])

The installed electrical and thermal capacities of EGS projects are summarized in Figure 2.15. Since EGS is still a developing concept, the database contains only 14 projects carried out with electricity generation [56].

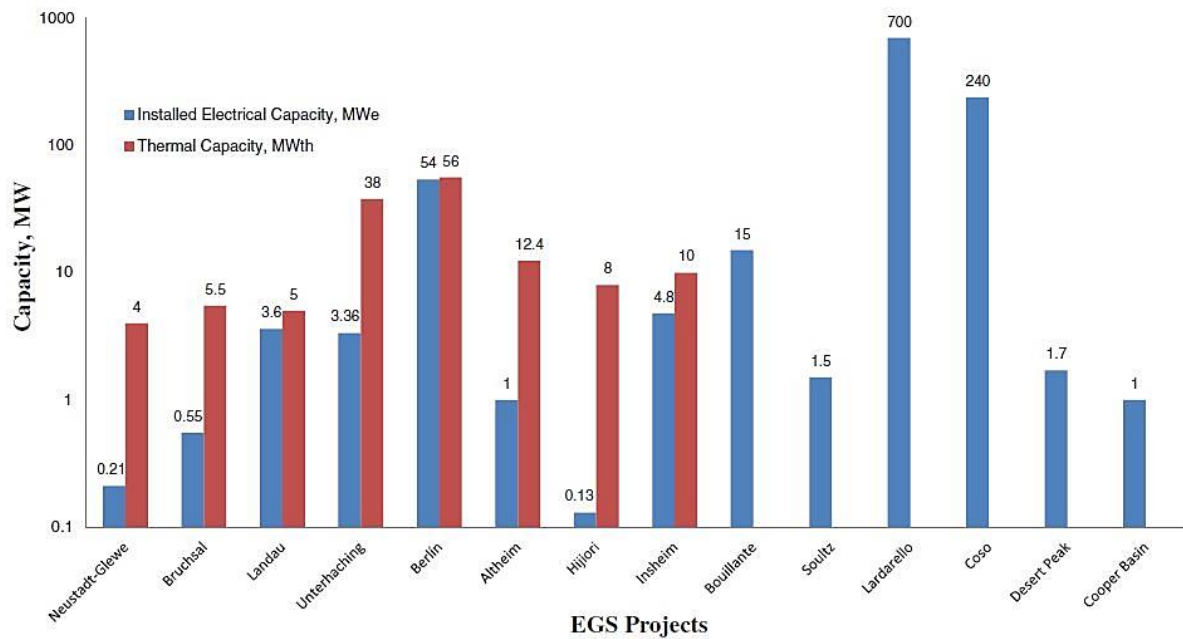

Figure 2.15. Installed electrical and thermal capacity of worldwide EGS projects (source: [56])

Along with the ongoing debate over the definition of EGS, it has also been reported that the output of EGS projects is far lower than the theoretical expectation [56].

As seen in Section 2.4.1. there are many publications on noticeable numbers about EGS potential, however from the extensive reviews shown in [2], [56], [58], [59] it is obvious that the EGS is still on the learning curve and far from the commercial implementation of this technology. Additionally, it can be concluded that the ‘typical’ EGS system does not exist mainly because there are several possible and significantly different geological, petrophysical, thermal, hydraulic, and geomechanical environments where high temperature resources can be tapped underground.

The learning process and learning curve must continue based on research and development, further technology advances and significantly more financial and political incentives and subsidies. To gain political support, the overall awareness of geothermal energy benefits, including EGS, must be risen and to gain public acceptance communities should be provided with regular, understandable, transparent and realistic information about EGS activities.

#### 2.4.4. Barriers and challenges for establishing enhanced geothermal energy utilization plan

Interestingly, different definitions of EGS have been proposed over the years, covering thereat broad variety of rock types, depth ranges, temperature ranges, reservoir permeability and porosity levels, type of stimulation techniques involved, etc. (Table 2.6). It is clear that



the universal definition of EGS is lacking in the geothermal community which may present the potential obstacle for the implementation of tailored subsidy programmes for such plants and projects.

Table 2.6. Definitions of EGS in the public domain

Source	Definition
[60]	The Massachusetts Institute of Technology (MIT) led an interdisciplinary panel which defined EGS as <i>‘engineered reservoirs that have been created to extract economical amounts of heat from low permeability and/or porosity geothermal resources. For this assessment, this definition has been adapted to include all geothermal resources that are currently not in commercial production and require stimulation or enhancement. EGS would exclude high-grade hydrothermal but include conduction dominated, low permeability resources in sedimentary and basement formations, as well as geopressured, magma and low grade, unproductive hydrothermal resources. Co-produced hot water from oil and gas production is included as an unconventional EGS resource type that could be developed in the short term and possibly provide a first step to more classical EGS exploitation’</i>
[61]	The Australian Geothermal Reporting Code Committee (AGRCC) considered EGS as <i>‘a body of rock containing useful energy, the recoverability of which has been increased by artificial means such as fracturing’</i>
[62]	Williams et al. defined the EGS as <i>‘EGS comprise the portion of a geothermal resource for which a measurable increase in production over its natural state is or can be attained through mechanical, thermal, and/or chemical stimulation of the reservoir rock. In this definition, there are no restrictions on temperature, rock type or pre-existing geothermal exploitation’</i>
[63]	The Bundesministerium für Umwelt, Naturschutz und Reaktorsicherheit (BMU) defines enhanced geothermal systems as creating or enhancing a heat exchanger in deep and low permeable hot rocks using stimulation methods. Following BMU's definition, EGS embraces not only HDR but also deep heat mining, hot wet rock, hot fractured rock, stimulated geothermal systems, and stimulated hydrothermal systems.

The barriers for establishing geothermal energy plans, including EGS can be categorized in four five groups institutional, regulatory, technological, financial, and others.

Potential barriers are listed in Table 2.7 [64]. To overcome those barriers and challenges different strategies could and should be implemented. According to [64] these include: (i) establishing policy and government responsibility, (ii) providing economic incentives and prices supports, (iii) internalizing externalities, public acceptance and investor mobilization, (iv) developing and localizing key technologies and industries, and (v) geothermal leasing.

Table 2.7. Potential barriers for establishing EGS energy plans (modified according to: [64])

<b>Category</b>	<b>Barriers</b>
Institutional	<ul style="list-style-type: none"> <li>▪ Local authorities' unawareness of geothermal energy system benefits</li> <li>▪ Land suitability and availability</li> <li>▪ Cumbersome tender process</li> </ul>
Regulatory	<ul style="list-style-type: none"> <li>▪ Policy and legal issues</li> <li>▪ Complicated legal and regulatory bureaucracy</li> <li>▪ Unclear regulations in environment impact assessment</li> <li>▪ Incompatibility and conflict between regulations and acts</li> </ul>
Technological	<ul style="list-style-type: none"> <li>▪ Lack of expertise within community/city government</li> <li>▪ Lack of exploration data</li> <li>▪ Lack of own technologies for drilling</li> <li>▪ Complexity of project and technology/high risk undertaking</li> </ul>
Financial	<ul style="list-style-type: none"> <li>▪ No economic feasibility – high upfront costs</li> <li>▪ High price for water use</li> </ul>
Others	<ul style="list-style-type: none"> <li>▪ Low public acceptance and awareness</li> <li>▪ Lack of partnership with stakeholders/private investors</li> <li>▪ Tender arrangement</li> <li>▪ Resistance to change (<i>status quo</i>)</li> </ul>

In this context, the evaluation model developed and presented in this thesis could potentially contribute to some of barrier's removal. Namely, the developed model and featured decision-making methodology could enable the increase of awareness of the benefits of geothermal energy, with emphasis on EGS. Additionally, it could provide support in educational purposes of future engineers and decision- and policymakers. Furthermore, it aims to provide a standardized evaluation method of EGS projects which considers site-specificity of such projects enabling therefore comparison of various projects in terms of geothermal energy application options and geothermal project sites.

## **AN OVERVIEW OF EXISTING TECHNO-ECONOMIC EVALUATION MODELS AND SOFTWARE PACKAGES (TOOLS)**

THIS CHAPTER offers a comprehensive overview of available evaluation models and software tools designed for the assessment of Enhanced Geothermal Systems (EGS). This topic has gained significant importance over the years, with the initial development of such models dating back to the late 1980s. The period from 2006 to 2018 witnessed a prolific phase during which several models and software packages were created to address the technical performance and cost considerations of EGS. Throughout this chapter, these existing models and software packages are presented, providing insights into their chronological development. Moreover, the chapter is concluded with a comparative analysis of these tools, aiming to highlight their respective strengths and weaknesses.

### **3.1. PREAMBLE**

One of the first financial estimates considering electricity production systems from hot dry rock (HDR) were conducted in [65]. This and other related research and project models date back to the Fenton Hill Hot Dry Rock project at Los Alamos National Laboratory (LANL) in the 1970s. This project resulted in the techno-economic HDR model in 1987. In the late 1980s this model was updated to HDRec and in 1990 to MIT-HDR (Massachusetts Institute of Technology) described in detail in [66] and used in [67] for comparison of the results of several published economic assessments where the breakeven electricity price was calculated as a function of gradient for four different technology cases. The results of the model are most accurate and reliable for plants between 25 MWe and 100 MWe installed capacity range since this was the range upon which most of the built-in cost correlations are based [67]. HDRec is a cost-benefit analysis program for geothermal projects that combines economic aspects with the technical characteristics of the surface installations and the hydrogeological and thermal properties of the subsurface [68]. Up to that point in time, the model and its upgrades were written in Fortran 77 programming language. This software was eventually rewritten using

Java language. At that point, the software package EURONAUT emerged in Europe [2]. EURONAUT is implemented on the basis of the studies conducted at the EGS power plant in Soultz-sous-Forêts. The root of the program is economic estimation via discounted cash flows and all other calculations are performed in separate modules, which can be linked together by interfaces. The modules can be changed or rearranged simply by mouse-clicks [52].

Considering again the LANL effort to make the MIT-HDR model more accessible to the general geothermal community, a Windows user interface was developed [69] in 2000 known as ‘EGS Modeling for Windows’. In 2006 this Windows version of the model became upgraded and officially known as MIT-EGS model and was used in the [60]. Around the same time, from 2004 till 2006, the Geothermal Electricity Technology Evaluation Model (GETEM) was originally developed, focusing on developing representative power generation from hydrothermal resources using either flash steam or air-cooled binary-cycle plants [60]. Initial development resumed in 2008 with the emphasis on characterizing generation costs from EGS resources. Additional updates and further development took place between 2011 and 2015 when the model’s depiction of project development was aligned with [43]. As described in [60] and [70], GETEM is a macro-model, an Excel-based tool that estimates the levelized cost of geothermal power plants in a commercial context [71]. Its development was funded by the U.S. Department of Energy Geothermal Technology Program. Furthermore, from 2012 to 2014 the MIT-EGS model was extensively modified which resulted in GEOthermal energy for Production of Heat and electricity Economically Simulated (GEOPHIRES) v1.0 [72], [73]. Numerous simulation examples are included in these papers, as much as in [74] and [75]. Later, during 2017-2018, other upgrades were implemented and GEOPHIRES v2.0 was developed [76]. Major upgrades in v2.0 are the updated cost correlations, more user flexibility in wellfield configuration and time-stepping, an enhanced wellbore simulator, the option to import external reservoir output data (e.g., from measurements), direct coupling to the stand-alone reservoir simulator TOUGH2, and conversion of the source code from FORTRAN to Python, thereby making the tool open-source.

Around the same time when GETEM was originally developed in the USA, the project funded by the European Commission, named Enhanced Geothermal Innovative Network for Europe (ENGINE), gathered experts from 16 European and 3 non-European countries. The 3 years’ work on the project has been synthesized in [77], presenting an overview of the investigation, exploration, and exploitation of unconventional geothermal reservoirs (UGR) and Enhanced Geothermal Systems (EGS) taking into account economic and socio-

environmental impacts. As part of the ENGINE, techno-economic performance assessment model for deep geothermal projects has been developed. This quantitative model has been developed as a simple techno-economic performance tool in Excel and based on analytical models developed for EGS [78], including a heat stored volumetric approach suggested by National Entity for Electricity (ENEL). These models have also been implemented in a dedicated decision support system (Engine DSS), using best practices for asset evaluation from the oil and gas industry.

Another techno-economic model designed to facilitate decision making for users involved in the renewable energy industry is The System Advisor Model developed by the National Renewable Energy Laboratory (NREL), described in details in [79]. The SAM was originally developed in 2005 and firstly used for the system-based analysis of solar technology improvements. However, since 2007 two new versions have been released each year, and since 2013 one new version per year, adding new technologies and financing options. SAM’s geothermal power block model is either based on the GETEM model or on the more sophisticated algorithm based on physical principles using the power block model developed for SAM's physical parabolic trough model.

As part of the GeoElec project that lasted from 2011 to 2013, a software for financial pre-feasibility studies was developed [80].

The chronological stages of development of each aforementioned assessment tool and software package are depicted in Figure 3.1.

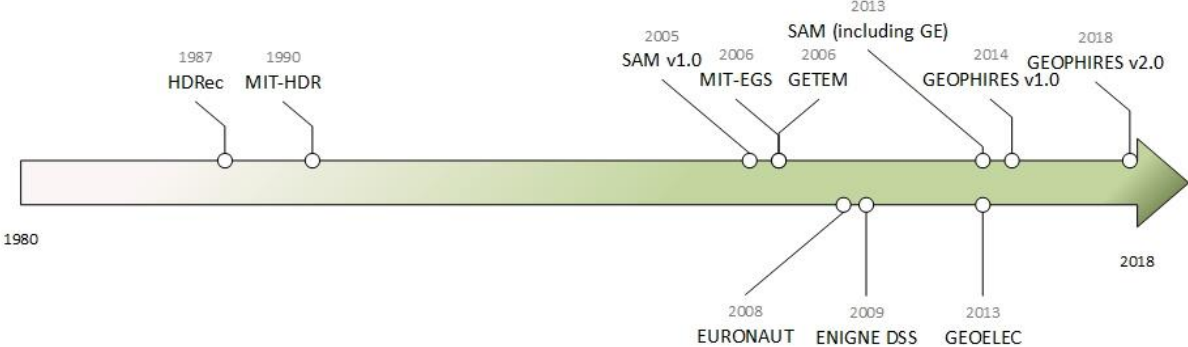

Figure 3.1. Timeline of development of models and software packages

### 3.1.1.1. GEOPHIRES

The first version GEOPHIRES v1.0 was built in the period from 2012 - 2014 upon the MIT-EGS model used for the extensive report “The Future of Geothermal Energy” [60]. The report represented a comprehensive assessment of enhanced or engineered geothermal systems and was carried out by an 18-member panel assembled by the Massachusetts Institute of

Technology (MIT) to evaluate the potential of geothermal energy becoming a major energy source for the United States.

The upgrade from the MIT-EGS included: (1) possibility of evaluation of direct-use heat and combined heat and power production (CHP) in addition to electricity generation; (2) inclusion of a standard discounted cash flow economic model besides a fixed annual charge rate model (FCR), and a BICYCLE model; (3) the option to specify thermal drawdown with an annual percentage temperature decline besides the parallel fractures model, the 1-D linear heat sweep model and the  $m/A$  thermal drawdown parameter model; (4) the simulation of production and injection wellbore heat transmission using Ramey's model (Ramey, 1962); (5) updated drilling and surface plant costs; and (6) the conversion of the GUI programming language from Visual Basic 6 into the .NET framework environment [72]. The new model GEOPHIRES could be used either as stand-alone program or as a subroutine to be prompted from another broader user-developed program, e.g., MATLAB. Furthermore, GEOPHIRES has the option to either simulate an EGS reservoir and power plant for given parameters, or to optimize their design, operating parameters and drilling depth to yield minimum levelized cost. Using the set of 96 input parameters GEOPHIRES v1.0 first simulated the production wellhead temperature over the lifetime of the plant, then calculated the annual generation of the end-use, and finally, combined with the capital and O&M costs, estimated the levelized costs of electricity and/or heat. The model was written primarily in FORTRAN 90, with some legacy parts of the code in FORTRAN 77. The GUI was implemented in VB 9.0 under the .NET Framework 3.5. Back then, GEOPHIRES v1.0 was only available for the Microsoft Windows platform.

To address the liabilities, as well as to update the cost correlations, improve code readability, and add several new modelling features, a new version (v2.0) has been developed during the period from 2017 – 2018. The upgrades include converting the source code from FORTRAN to Python, making the tool open-source, updating the built-in cost correlations, enhancing the wellbore simulator, and directly coupling it to the external reservoir simulator TOUGH2 [81]. This GEOPHIRES v2.0 is distributed as open source under the permissive MIT license. GEOPHIRES v2.0 has been designed to be a flexible, user-friendly, and robust computer tool for assessing technical and/or economic performance of a geothermal system with a wide possible level of simulation detail. By relying on built-in correlations and default values, a basic simulation can be performed with limited knowledge on subsurface, surface plant, and financing conditions [81]. Additionally, more-experienced users can perform a more in-depth analysis, or hard coding in a specific surface plant application.

### 3.1.2. GETEM

The Geothermal Technologies Office (GTO) uses the Geothermal Electricity Technology Evaluation Model (GETEM) to understand the performance and cost of energy technologies that GTO seeks to improve. The model helps GTO to determine which proposed research, development, and deployment (RD&D) programs and projects might offer the most efficient improvement when based on taxpayer funding [82].

GETEM is an Excel-based tool for estimating the levelized cost of energy for pre-defined or user defined geothermal scenarios. It is a detailed model of the estimated performance and costs of currently available U.S. geothermal power systems. It can be used to analyse and evaluate the state of existing technologies and estimate the cost of certain technologies 5–20 years in the future, given the direction of potential RD&D projects.

Electricity generation is the sole geothermal use considered by GETEM. The model does not provide assessment capabilities for geothermal heating and cooling technologies. It can evaluate a hydrothermal or an enhanced geothermal system resource type, and then either a flash-steam or air-cooled binary power plant based on specific resource parameters. GETEM does not evaluate generation costs for water-cooled binary plants or air-cooled flash plants.

A discounted cash flow (DCF) methodology is used to determine the LCOE. Additionally, the estimates of the LCOE for power generation do not consider incentives that may be available for renewable power generation.

The estimates of power generation over the life of the project are based on the premise that the resource temperature declines with time, while the geothermal flow rate remains constant.

The latest 2016 version is an update of the previous 2012 Beta Version of the GETEM tool, which focuses on the use of an enhanced geothermal resource with an air-cooled binary power plant. Prior to this work, GTO did not have specific predefined scenarios for assessing the impact of technology on generation costs. As part of the interviews with industry, information was solicited to validate or revise, as necessary, model inputs to account for the variability in resource quality (temperature and productivity) and resource depth. On the basis of this information GTO developed specific EGS and hydrothermal resource scenarios that are the basis for evaluating the impact of recent and future technology advances on generation costs.

One issue with the earliest versions of the model was the use of fixed values in the calculations that could not be changed and were not always apparent to users. When development work resumed in 2008, these fixed values became model inputs. This practice

continued through the work done by the LCOE analysis team. When work by this analysis team was completed, there were around 240 inputs to the model, making GETEM intimidating to use if one lacked sufficient experience and expertise to provide representative inputs for all elements of the geothermal project development. To facilitate the broader use, default inputs were developed based on the work done by the LCOE analysis team and subsequent validation efforts. At present, GETEM defaults to a specific set of inputs that are based on the specified resource type, temperature, and depth. Of these defaults, 113 can be revised by the user. These inputs were selected for possible revision based on sensitivity analyses done for both EGS and hydrothermal scenarios to identify those inputs having the greatest impact on the LCOE.

### 3.1.3. EURONAUT

The main focus of this software was the ability for continuous adaptation and growth in modular arrangement. Only the economic approach of discounted cash flows (DCF) was set as a kind of root to the software. All other calculations are performed in separate modules, which can be linked together by various interfaces [52]. The modules can be altered or rearranged simply by click of the mouse, and the modular nature of the software makes it easier to introduce changes in its development, improving and implementing results from other programs. All elements of the EGS system are implemented in modules and not in the EURONAUT software itself. As a side effect, the EURONAUT software is not limited to EGS calculations only but can handle any kind of economic evaluation. Payments evolving during the entire lifetime phases of the project: the investments, the operating costs, the revenues and the dismantling costs are applied to the evaluation. The EGS system is wrapped into modules resulting in a “tree-like” structure. Calculating the cash flows for all modules and for the whole lifetime cycle, the financial characteristics of the project are determined. The main results are the econometric project indicators such as: the net present value (NPV), the return on investment (ROI) and the prime costs [52].

Based on the experience which was gained at Soultz-sous-Forêts, EURONAUT set up two structures. The first one is a simplified two well (doublet) system where all properties are dependent of the reservoir depth: mainly the temperature of the fluid for heat extraction, the drilling costs and the permeability of the rocks. As a result, the depth dependent effective costs for running a plant are determined. The second one is a module for multi-well system, such as the actual situation of the EGS plant at Soultz-sous-Forêts with the individual features of all four existing and operating wells GPK1, GPK2, GPK3 and GPK4.



#### 3.1.4. GEOELEC

In order to increase confidence and boost investigations into new geothermal projects, this software has been designed for project developers and public authorities that are investigating the potential of new geothermal power plants. Project costs, the financing model and business plan can now be pre-checked and validated using this simple tool. Specifically, users can check Internal Rate of Return (IRR), Net Present Value (NPV), payback time, levelized cost of electricity production (LCOE), profit and loss, balance sheet, and cash flow associated to the project [80]. This software can be used with all three geothermal electricity generation technologies: conventional geothermal (hydrothermal, high temperature) with dry steam and flash steam turbines; low temperature hydrothermal geothermal with binary turbines (ORC and Kalina Cycle); and Enhanced Geothermal Systems (EGS).

#### 3.1.5. ENGINE

Excel-based techno-economic performance assessment tool (enginePA.xls) and dedicated decision support system (EGS-DSS) were developed as part of the ENGINE (Enhanced Geothermal Innovative Network for Europe) project using best practices for asset evaluation from oil and gas industry.

The project was a coordination action supported by the 6th Research and Development framework of the European Union. Its main objective was to coordinate research and development initiatives for Enhanced Geothermal Systems from resource investigation to exploitation through socio-economics impacts assessment.

Therefore, a simple techno-economic performance tool in Excel (enginePA.xls) was developed to quantitatively understand the economic impact of key technical and economic parameters in EGS at different phases in the workflow, from exploration to production, [78]. The quantitative model is based on two different physical analytical models developed for EGS used to describe the energy extracted from the reservoir. The first one is a streamline fluid flow approach for porous aquifers and fractures [68], and second one a heat stored approach based on a recovery factors for the so-called heat in place in the reservoir suggested by ENEL (courtesy R. Bertani). Additionally, the Excel model is designed for a multiple doublet approach with a fluid circulation in a subsurface reservoir. The construction of this model is separated in 4 main groups of parameters: basin and reservoir properties, underground development, surface development, commercial aspects and financial aspects. The Excel calculation spreadsheet provides basic insight into the way the calculations are

performed and allows the user instant access to the sensitivity of his model outcomes to changes in the input parameters. The spreadsheet can be easily modified and extended for project-specific calculation models.

With the EGS-DSS, probabilistic calculations can be quickly performed, and users can evaluate their decision trees and perform advanced sensitivity analysis for each branch. In addition to generating Excel spreadsheets, the EGS Decision Support System (EGS DSS) can perform probabilistic (Monte Carlo) simulations. The model parameters are subdivided into the same model components as for the Excel spreadsheet. Each of these parameters can be defined as a distribution. This approach allows consideration of natural uncertainties and decision trees to evaluate sensitivities and different scenarios. Doing so the performance of geothermal systems can be evaluated by investigating sensitivities of the performance due to both natural uncertainties beyond control (e.g. flow characteristics, subsurface temperatures), engineering options (bore layout and surface facilities options) and economic uncertainties (e.g. electricity price, tax regimes) [83].

### 3.1.6. SAM

The System Advisor Model (SAM) is a free techno-economic software model that facilitates decision-making for subjects involved in the renewable energy industry. SAM can model many types of renewable energy systems including geothermal power generation from the year 2013. The Geothermal Power model represents a power plant that uses heat from below the surface of the ground to drive a steam electric power generation plant [79].

SAM's geothermal power model is based on the U.S. Department of Energy's Geothermal Electricity Technology Evaluation Model (GETEM). The model calculates the annual and lifetime power output of a utility-scale geothermal power plant, the levelized cost of energy and other economic metrics for the plant. SAM analyses the plant's performance over its lifetime, assuming that changes in the resource and power output occur monthly over a period of years.

## 3.2. COMPARISON OF AVAILABLE TECHNO-ECONOMIC MODELS AND SOFTWARE PACKAGES

Above mentioned software packages and models have been used in some of the most influential projects or institutions [84]–[87], as much as in many types of research [60], [52], [73]. Comparison of some fundamental parameters between the tools is shown in Table 3.1. It

is indicative that, while GEOPHIRES can model various end-use options (electricity, direct-use heat, cogeneration), MIT-EGS, GETEM, EURONAUT, ENGINE, GEOELEC, and SAM only model electricity generation. Moreover, only ENGINE, EURONAUT, and GEOELEC are completely applicable to the European markets, since they have been developed as part of the EU projects and research [84], [85], and all the other tools have been developed by American institutions [86]–[88], and for the purposes of geothermal projects and research in the USA. Furthermore, aside from being simulation models, MIT-EGS, GEOPHIRES and GETEM allow the user to use the model in an optimization mode, delivering the optimum output result for inserted set of input parameters. Although the models allow the installed capacity to be of any size, most of the models suggest the optimal ranges of installed capacity. Namely, the results inside those ranges are the most accurate and reliable, since the built-in cost correlations have been made according to the expert's knowledge, past experiences and project examples.

As for the economic indices, the most used economic metrics in the literature [28], [89], [90] and reviewed models are the levelized cost of electricity (LCOE) or heat (LCOH), followed by the net present value (NPV) and internal rate of return (IRR). Moreover, almost all reviewed models and software packages use either integrated default cost correlations to calculate total capital costs and total annual operation and maintenance (O&M) costs, or user-defined costs for each phase of the project, and power plant equipment. However, it is noticeable that among input parameters, the parameters related to the subsurface (e.g., resource characteristics, reservoir model etc.) make the majority and are extensively modelled, while surface technical parameters, i.e., technology and power plant specifications, are less detailed. An indisputable example is the grid connection cost and the related conditions that should be satisfied. Namely, this parameter could play a crucial role in the realization of some geothermal projects, and only GETEM, ENGINE and SAM have this parameter somehow included in the calculations. By default, transmission lines costs are not included in calculations of LCOE in the GETEM model, but with some modifications of the model, they could eventually be considered. Further, ENGINE model uses a simplified approximation of capital expenditures (CAPEX) for connection to the grid as a distance to the grid multiplied by the specific costs per kilometre. SAM, however, can include those costs only as part of the surface equipment installation costs. Several factors which could notably affect the LCOE and/or LCOH are not taken into account in the GEOPHIRES [8]. These include, among others: permitting and federal leases, subsidies and tax incentives, learning effects in drilling, and the costs of transmission lines or pipelines to the end consumer.

Only GEOPHIRES and enginePA.xls are open-source, allowing other researches to expand upon the tool. All other tools and software packages are either protected (if Excel-based) or do not provide the backend code to provide the information on how they are modelled.

Table 3.1. Comparison of currently available models and software packages for techno-economic assessment of EGS projects

<b>Tool name</b>	MIT-EGS	GEOPHIRES	GETEM	EURONAUT	ENGINE	GEOELEC	SAM
<b>Tool type</b>	Software	Software	Excel	Software	Excel Software	Excel	Software
<b>Number of input parameters</b>	50	92 (96)	113 (240)	54	72	10	123 (145)
<b>End use option</b>							
Electricity generation	✓	✓	✓	✓	✓	✓	✓
Direct heat usage		✓					
CHP		✓					
<b>Temperature range [°C]</b>	160-260	50-400	200-325 75-200	N/A	> 85	120-170	75-200
<b>Power plant type</b>	Flash Binary (ORC)	Flash Binary (ORC)	Flash Binary (ORC)	Binary (ORC)	Binary (ORC)	Binary (ORC or Kalina)	Flash Binary (ORC)
<b>Best installed capacity range (cost correlations) [MWe]</b>	25-100	> 10	> 10 > 3	N/A	N/A	N/A	> 10 > 3
<b>Economic outputs</b>							
LCOE	✓	✓	✓	✓		✓	✓
NPV		(✓)*		✓	✓	✓	✓
IRR		(✓)*			✓	✓	✓
Payback period		(✓)*			✓	✓	✓
Return on investment				✓			
Cash flow			✓		✓	✓	✓
Profit and loss		✓	✓	✓	✓	✓	✓
Total capital cost	✓	✓	✓	✓	✓		✓
Total annual O&M cost		✓	✓	✓	✓		✓
<b>Simulation model</b>	✓	✓	✓	✓	✓	✓	✓
<b>Optimization model</b>	✓	✓	✓				
<b>Applicable to the European markets</b>	✓/✗	✓/✗	✓/✗	✓	✓	✓	✓/✗
<b>Connection to grid</b>			✓/✗**		✓/✗***		✓/✗****
<b>Open source</b>		✓			✓		

\*Only with code modification it would be possible to calculate those parameters  
\*\*Possible to set transmission lines costs, but not included in calculations of LCOE by default  
\*\*\*CAPEX for connection to grid calculated distance multiplied by cost per km  
\*\*\*\*Only as part of the surface equipment installation costs

## MULTI-CRITERIA DECISION-MAKING

THE MULTI-CRITERIA DECISION-MAKING CHAPTER provides the theory on a branch of a general class Operations Research models called multi-criteria decision-making methods. Decision-making is the process of identifying and choosing between alternatives to find the best solution based on different factors and considering the decision-makers' expectations. Every decision is made within a decision environment, which is defined as the collection of information, alternatives, values, and preferences available at the time when the decision must be made. The difficulty in decision-making process is that it is usually very complex and requires simultaneous evaluation of different influencing factors and assessment of complex mix of involved subjects' preferences. Namely, in most of the cases, different groups of decision-makers with different expectations and level of expertise are involved in the process. To facilitate this type of analysis, a group of tools referred to as multi-criteria decision-making methods gained importance due to the need to have a formalized method to assist decision-making in situations involving multiple, often conflicting, criteria. The multi-criteria decision-making (MCDM) process typically unfolds through several key stages, which can be delineated as follows: 1) criteria identification and selection; 2) determination of criteria weights; 3) determination of the ranking of possible alternatives; 4) aggregation of the results of preference ranking order (if applicable). Throughout each of these stages, various methods and techniques can be employed to facilitate the decision-making process. Therefore, in this Chapter mainly used criteria selecting methods, weighting methods, and ranking methods are summarized and described. The Chapter is concluded with tabular comparison of mostly used MCDM methods.

### 4.1. PREAMBLE

Multi-criteria decision-making (MCDM) is a branch of a general class of Operational Research (OP) models [93], [94], which deal with finding the optimal results among complex scenarios considering various indicators, conflicting objects and criteria. The MCDM is further divided into two groups multi-objective decision making (MODM) and multi-attribute decision making (MADM) based on a number of alternatives under consideration [95].

These methodologies have same characteristics related to conflict among criteria, incommensurable units and difficulties in design/selection of alternatives. The main difference between the two groups of methods is the number of alternatives under evaluation. MADM methods are designed for selecting discrete number of alternatives while MODM are suitable for evaluation of continuous alternatives for which we predefine constraints in the form of vectors of decision variables [91]. In MODM (also known as multi objective programming or a vector optimisation/maximisation /minimization problem) the alternatives are not predetermined but a set of objective functions are optimized considering the constraints while degrading the performance of one or more objectives [92]. Namely, MODM focuses on continuous decision spaces. It is an optimization problem with no direct and specific alternative chosen as a solution, rather the feasible region (where the alternatives are situated) is considered as solution to the decision-making problem [93]. Additionally, criteria are goals and attribute are implicit and while there is no clear goal and option, the limitations are clear, and decision-makers have high level of interaction. On the other hand, MADM concentrates on discrete problems. Here, goals, attributes (that are criteria) and options (alternatives) are clear, however the limitations are unclear and the interaction between decision-makers is somewhat limited. In MADM, characteristics that are inherent are covered leading to consideration of fewer number of alternatives and thus evaluation becomes difficult as prioritizing becomes more difficult. The final result is decided by comparing various alternatives with respect to each attributes considered [91].

There are different methods developed to solve multi-criteria decision problems and the various classification ways (apart from the general base classification mentioned in the text above) of existing methods are to be found in public domain based on diverse characteristics. One way it to classify them according to the type of the data they use [94]. Based on that, three distinctive categories of MCDM methods exist, *deterministic*, *stochastic*, and *fuzzy methods*. However, there may be situations which involve combinations of all three of the categories. Additionally, the methods can be classified according to the number of decision makers (DM) involved in the decision process. Hence, there are *single* decision maker MCDM methods and *group* decision making MCMD methods. The methods can also be classified based on the type of decision model they apply. Namely, the developed models are as per designer perspective [91]. It can be a direct or indirect approach. In direct approach the assignment of priorities or weights are being done because of inputs from the beneficiary, society or acquaintance based on the survey. In a direct method, all possible criteria are separated in components and assigned weights as per previous similar problems, judgement of

DM based on experience, etc. Such methods can be classified into *outranking methods*, *utility-based methods*, and *other miscellaneous methods* [95]. Furthermore, MCDM methods can be classified based on the levels of information on the decision-making environment, and the relevant feature of that information [96]. That classification includes *dominance methods*, *maximin and minimax*, *maximax*, *conjunctive or disjunctive methods*, *lexicographic or elimination by aspect*, *weighting or scaling methods*, and *mathematical programming models which use various types of weights for the decision variables*. Dominance methods can either be probabilistic or deterministic. They require the least information about the decision-making environment and indicate an alternative is dominated if there is another alternative that is superior in one or more attributes with the remaining attributes equal. If some information exists about the decision-making environment, specifically the attitudes of decision makers towards levels of risk associated with an outcome, then maximin and minimax, or maximax methods can be used. In order to implement conjunctive and disjunctive methods, a hierarchy of needs has to be identified and levels of sufficiency defined for and agreed upon by the decision-making group. Conjunctive methods require that all attributes of the policy alternatives under consideration must have a minimum acceptable level; while disjunctive methods require that only one attribute of the candidate alternatives must be above an acceptable level. Therefore, conjunctive methods differ from disjunctive methods by the number of minimum standards that must be met. These methods are also often referred as outranking methods. A number of methods use sequential or successive elimination of policy alternatives based upon pair-wise comparison of their attributes [96]. Lexicographic methods compare alternatives on the basis of their most important attribute, where elimination by aspects, compares one attribute of the candidate alternatives at a time without ranking importance. Scoring or weighting methods are “compensatory” methods that allow for the evaluation of trade-offs between the attributes of candidate alternatives. Attributes are grouped and each group is assigned with specific weight that very often represents a partial contribution to the overall score based on the importance of the group of attributes to the decision maker. Most widely used types of MCDM methods are those that employ mathematical programming models. Mathematical programming methods generate from many possible alternatives a small subset of non-dominated alternatives whose trade-offs can then be studied. The decision variables included in a single objective or multiple objective function(s) usually represent the distances from a goal established for each objective. In [97] different MCMD methods have been reviewed and classified according to different stages of multi-criteria decision-making for sustainable energy, i.e., criteria selection, criteria

weighting, evaluation (ranking of alternatives), and final aggregation. When evaluating a system (goal) of the decision-making problem there are numerous criteria that could be characterized as having an influence on the goal. Furthermore, there may be repeatability and different levels of relevancy in the criteria system. Therefore, it is important that some rational methods are applied to select the “major” criteria distinguishing thereby the main and secondary important influencing criteria. Some of the often-used selection criteria are shown in Figure 4.1. After the criteria selection stage, it is necessary to determine each criteria’s relative impact in the decision-making problem. Namely, generally, not all identified criteria have same relative importance in the decision-making problem, i.e. some influence the solution space more than others. At this stage, some of the weighting methods are used, which are explained in more detail in Section 4.4. Assigned weights to each criterion represent the relative importance of each criterion and different weights influence directly the decision-making result of alternatives. Once the criteria have been associated with weights, the determination of preference orders of alternatives can be carried out. In other words, different MCDM methods can be employed to obtain the ranking order of the criteria. Usually, the decision-making problem ends with this stage when a DM selects the best alternative based on the ranking after the calculation in a selected MCDM method. However, sometimes the credibility of DM is verified so that the results of the ranking orders are computed with a few MCDM methods. Consequently, the application of various MCDM methods to obtain the ranking order of alternatives may yield different result (preference ranking order). Since it would be hard and inefficient to determine which ranking methods is the best and most suitable to solve the ranking problem, the ranking results are necessarily aggregated again the best ranking order of alternatives is selected.

The general stages of the MCDM process can be divided as (i) criteria identification and selection, (ii) determination of criteria weights, (iii) determination of the ranking of possible alternatives, and in some cases, not always (iv) aggregation of the results of preference ranking order (Figure 4.1). In each stage of the MCDM process different methods could be used, as explained in the text above and some of the methods used in each stage related to the sustainable energy decision-making are depicted in Figure 4.1.



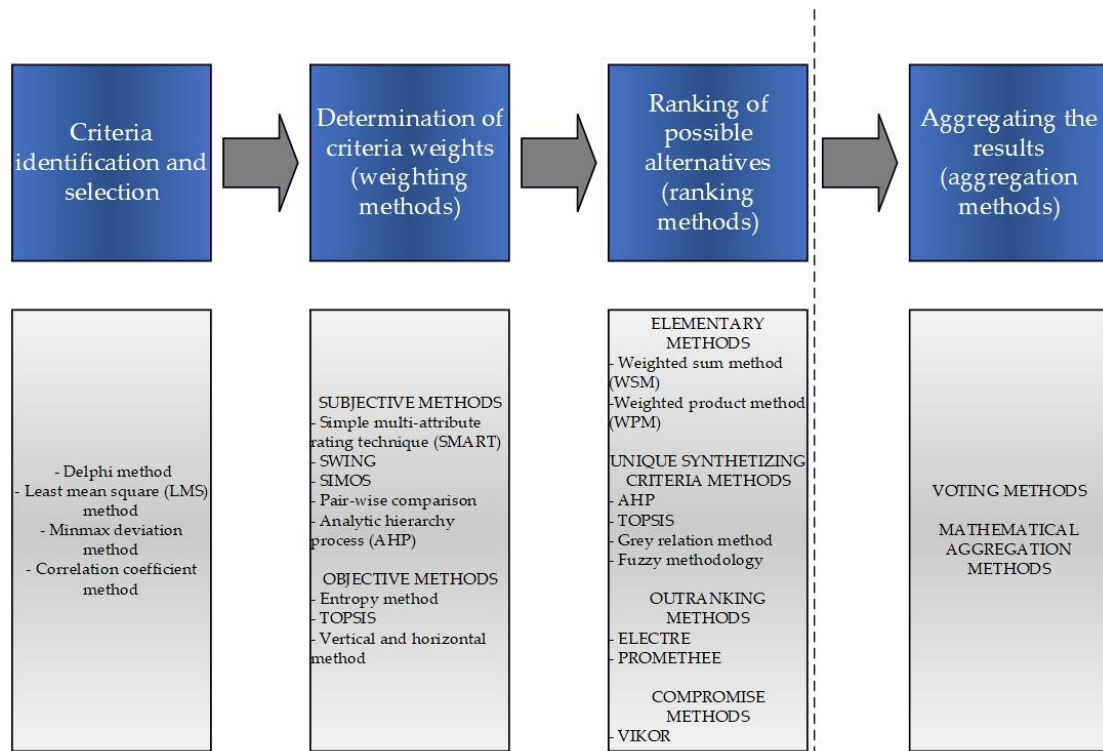

Figure 4.1. General stages of MCDM process (depicted according to the review done in [97])

## 4.2. GENERAL APPROACH

When making a decision, decision-makers (DM) tend to choose the optimal solution. However, an optimal solution exists only in case of one single criterion; in real decision-making processes, almost any decision involves some conflicts or dissatisfaction. The key starting point of MCDM lies in attempting to represent often impalpable goals in terms of a number of different individual criterion. As a matter of fact, there are two main issues correlated to the multi-criteria problem: how to measure what is known as impalpable, and how to combine their measurements to produce an overall preference or ranking; and finally, how to use it to make a decision with the best available mathematics [98]. After the definition of the system with the objectives to be met, i.e. the goal, all the criteria affecting the system is to be found based on these objectives. The process continues with seeking of alternative systems. Alternatives to the system represent the different choices of action available to the decision-maker. Usually, the set of alternatives is assumed to be finite, ranging from several to hundreds [94]. All the possible criteria are separated, and weights are assigned to each of the criteria, representing the relative importance of each criterion in the decision-making process. The assignment of the weights is based on the existing know-how, i.e. the judgement of decision-maker based on their experience. Thus, this decision-making procedure remains a bit controversial, as objectives can lead to different solutions at different times based on the

priority of criteria set by the decision-makers. Moreover, the MCDM processes are commonly very complex due to the involvement of a set of criteria from different areas (technical, institutional, social, environmental etc.). After the definition of criteria and alternatives, and the assignment of the weights, the MCDM method is selected to rank the alternatives. Namely, particular multi-criteria problem can be approached by different methods based on the defined functions and objectives. Based on the definitions and information from Section 4.1 and 4.2, the general structure of the described MCDM process is illustrated in Figure 4.2.

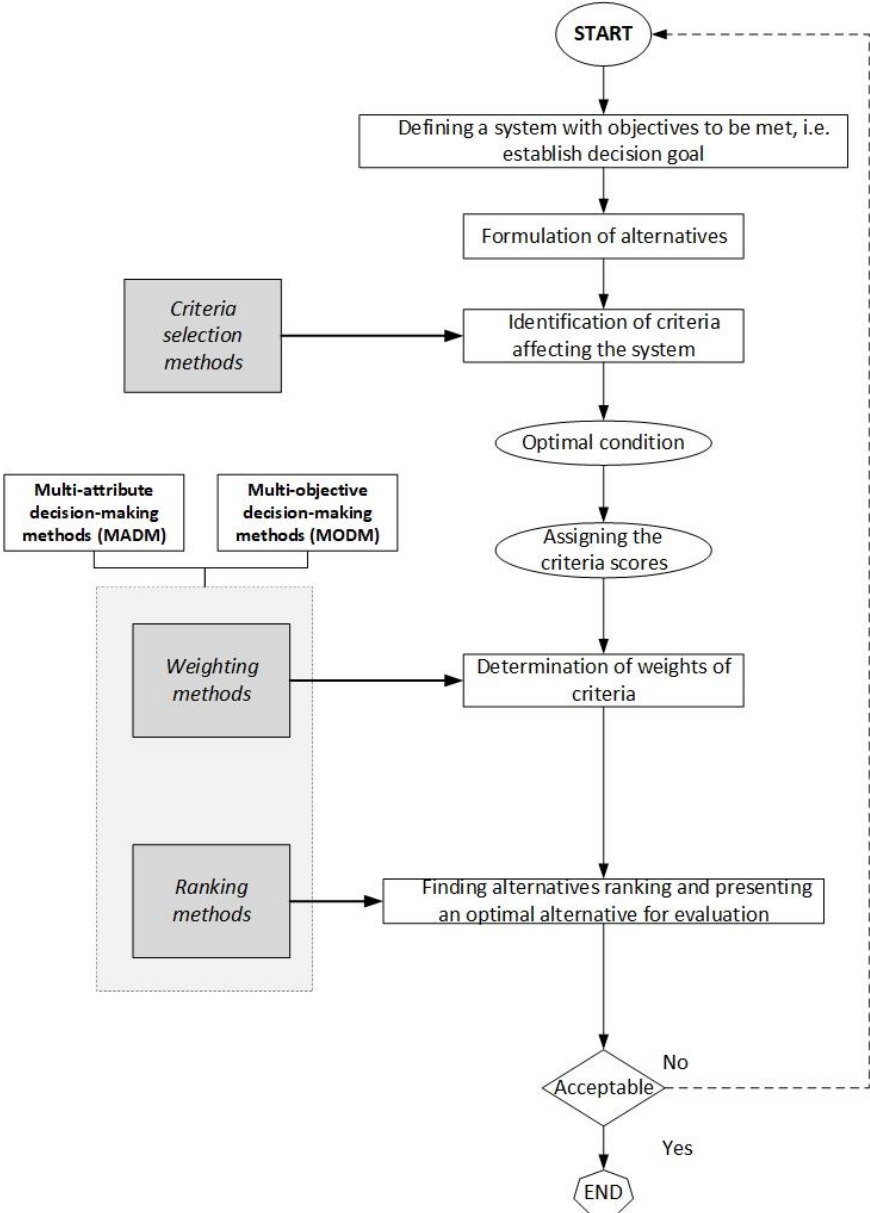

Figure 4.2. General structure of MCDM process

Diversity of MCDM analysis framework offers multiple approaches, from simple methods, requiring very little information to quite sophisticated and complex methods based on mathematical programming techniques, requiring broad information on each criterion

including also the preferences of the DM. Nonetheless, all multi-criteria problems have common characteristics [96]:

- a finite number of alternatives, which can be prioritized and ranked;
- numbers of criterion which depend on the nature of the problem;
- sets of units specific to the measurement of each criterion;
- potential for characterization of the relative importance of each criterion, and
- a matrix format, where columns indicate criterions considered in a given problem and rows list of competing policy alternatives.

#### 4.2.1. Basic notation

In this section the basic notation for MCDM is introduced. Let  $A$  be the finite set of  $m$  alternatives (actions, scenarios, cases, options, etc.) that must be ranked in order to obtain the best solution of decision-making problem represented by  $A = \{a_1, a_2, \dots, a_m\}$ . The alternatives are evaluated according to certain criteria. This set of criteria,  $F$ , consists of  $n$  of criteria that can have different domains, and may represent a cost (which is desirable to minimize) or a benefit (desirable to maximize) and it represented by  $F = \{f_1, f_2, \dots, f_n\}$ . Therefore, for example, alternatives  $a_1$  and  $a_2$  are  $n$ -dimensional vectors:

$$\mathbf{a}_1 = \{a_1^1, a_1^2, \dots, a_1^n\}, \quad \mathbf{a}_2 = \{a_2^1, a_2^2, \dots, a_2^n\}, \quad (4.1)$$

where  $n$  is the number of selected criteria.

Each  $i$ -th alternative ( $i = 1, 2, \dots, m$ ) assumes for the  $j$ -th criterion ( $j = 1, 2, \dots, n$ ) the actual value  $f_{ij}$ . The values of the  $j$ -th criterion for the  $m$  alternatives can be collected in a  $m$ -dimensional vector as:

$$\mathbf{f}_j = \{a_{1j}, a_{2j}, \dots, a_{mj}\} \quad (4.2)$$

Each criterion then can be weighted to take into account the different importance of the criteria in the decision-making problem. The weight vector is  $n$ -dimensional vector defined as:

$$\mathbf{w} = \{w_1, w_2, \dots, w_n\} \quad (4.3)$$

Following constraints are applied for the weight vector:

$$0 \leq w_j \leq 1, \quad (4.4)$$

$$\sum_{j=1}^n w_j = 1, \quad (4.5)$$

$$j = 1, 2, \dots, n \quad (4.6)$$

Without loss of generality, it is supposed that the criteria are defined in increasing sense, that is the DM prefers large to smaller values for each  $f_j$ .

The original decision matrix is represented as follows:

$$X = [x_{ij}]_{m \times n} = \begin{bmatrix} x_{11} & \cdots & x_{1n} \\ \vdots & \ddots & \vdots \\ x_{m1} & \cdots & x_{mn} \end{bmatrix}, \quad (4.7)$$

where  $x_{ij}$  is a real number and denotes the result of scheme  $a_i$  for criteria  $f_j$ .

According to the definition above, the definition of the MADM problem can be expressed as combining the original decision matrix  $X$  and the weight vector  $w_j$  of each criterion and evaluating the best solution in the solution set  $A$ .

A ranking function  $R$  is a function associates each alternative  $m$  with its rank, i.e. its position within the  $m$ -dimensional set of alternatives. It can be assumed that the best alternative has rank 1 and the worst alternative the rank  $m$ . Given a vector  $\mathbf{x}$  of  $m$  values, a ranking function  $R$  can be defined as:

$$R(\mathbf{x}): R^m \rightarrow r \in R, \quad 1 \leq r \leq m \quad (4.8)$$

The value produced by a ranking function is an integer if no object with the same rank is found, but it is a real value if the average ranking is calculated for objects having the same rank [98]. Therefore, a ranking function associates to the  $i$ -th alternative value  $x_i$  a ranking value  $r_i$  with respect to the  $m$  values as:

$$R(x_i | \mathbf{x}) = r_i, \quad 1 \leq r_i \leq m \quad (4.9)$$

Hence, the term  $r_{ij}$  indicates the rank of the  $i$ -th alternative for the  $j$ -th criterion.

### 4.3. CRITERIA SELECTING METHODS

Criteria selection is the first stage of the MCDM process, as depicted also in Figure 4.1. Generally, the following principles should be obeyed to select the main influencing criteria used in decision-making [97]:

1) *Systematic principle*

The criteria system should fully reflect the essential characteristic and the whole performance of the decision-making problem systems.

2) *Consistency principle*

The criteria system should be consistent with the decision-making objective.

3) *Measurability principle*

The criteria should be measurable in quantitative value or qualitatively expressed.

4) *Comparability principle*

The decision-making result is more rational if the comparability of the is more obvious. Furthermore, the criteria should be normalized to compare or operate directly when there are both benefit and cost criteria.

These principles are not always easy to follow. Some decision-making problems represent heavy task in terms of selecting and defining the set of main influencing criteria. Therefore, some of the most used methods for criteria selecting are briefly described in the following text.

#### 4.3.1. Delphi method

The Delphi method is a interactive and systematic method which relies on consensual agreement of a panel of independent experts. The principle of this method lies on the premise that forecasts from a structured group of experts are more accurate than those from unstructured groups or individuals [99]. The carefully selected experts answer questionnaires for criteria selection to evaluate energy systems in two or more rounds. After each round, the summaries of the experts' selection from the previous round as well as the reasons they provided for their judgments are fed back to the experts. Hence, the experts can adjust their answers from the previous round. During this process, the range of the criteria usually decreases, and the group converges to the "major" criteria. The process stops when the pre-defined stop criterion has been reached (e.g., number of rounds, achievement of consensus among the group, etc.)

#### 4.3.2. Least mean square (LMS) method

The principle of LMS method is that one criteria contributes less importance to results and it can be ignored when its performances of alternatives are almost same or near although the criteria is vital in evaluation [97].

$$s_j = \sqrt{\frac{1}{m} \sum_{i=1}^m (x_{ij} - \bar{x}_j)^2}, \quad (j = 1, 2, \dots, n), \quad (4.10)$$

$$\bar{x}_j = \frac{1}{m} \sum_{i=1}^m x_{ij}, \quad (4.11)$$

where  $x_{ij}$  is the  $i$ -th sample of  $j$ -th criteria ( $i = 1, 2, \dots, m$ ). If there exists  $k$  to make  $s_k = \min_{1 \leq j \leq n} \{s_j\}$  and  $s_k \approx 0$ , the  $k$  criteria that corresponds to  $s_k$  can be removed from the list.

#### 4.4. WEIGHTING METHODS

Weight is assigned to each criterion to indicate its relative importance in the decision-making problem. Generally, there are two main group of methods: (i) the equal weights and (ii) the rank-order weights. Both methods groups are equally applied as seen from the literature available in public domain.

In equal weights method the criteria weight is defined as:

$$w_i = \frac{1}{n}, \quad i = 1, 2, \dots, n \quad (4.12)$$

This method requires minimum knowledge of the decision maker's priorities and minimal input from the decision maker. However, it has often been criticized for not considering relative importance among criteria. Therefore, the rank-order weighting methods emerged.

In rank-order weighting methods the criteria weights are distributed as:

$$w_1 \geq w_2 \geq \dots \geq w_n \geq 0 \quad (4.13)$$

$$\sum_{i=1}^n w_i = 1 \quad (4.14)$$

The rank-order weighting methods can be classified into three categories [97]: subjective weighting methods, objective weighting methods, and combination weighting methods.

Criteria weights obtained with the subjective weighting methods depend only on the preference of decision-makers, not on the quantitative measured data of the related project. In contrary, the objective weights are obtained by mathematical methods based on the analysis of the initial data. The subjective weighting methods explain the evaluation clearly while the objectivity ones are relatively weak. Additionally, the judgments of decision-makers sometimes absolutely depend on their knowledge or information. Hence, the criteria weights' errors in some extents are unavoidable. Some of the basic and most representative weighting methods are summarized in Table 4.1. Additionally, only the most representative and mostly used methods are briefly described in the following Sub-Sections 4.4.1 and 4.4.2. Others can be found in other respective literature.

Table 4.1. Basic weighting methods in MCDM process

Category	Weighting method
Equal weights	-
Rank-order weights	
Subjective weighting	Simple multi-attribut rating technique (SMART)
	SMARTER
	Pair-wise comparison
	Analytic Hierarchy Process (AHP)
	Least-square method
	Eigenvector method
Objective weighting	Least mean square method (LMS)
	Entropy method
	Technique for order preference by similarity to ideal solution (TOPSIS) method
	Vertical and horizontal method
Combination weighting	Multiplication synthesis
	Additive synthesis

#### 4.4.1. Subjective weighting methods

In the SMART method the participants (decision-makers) are asked to rank the importance of the changes in the criteria from the worst criteria levels to the best levels. Then, 10 points is assigned to the least important criteria, and increasing number of points (with no upper limit) are assigned to the other criteria to address their importance relative to the least important criteria. The weights are calculated by normalizing the sum of the points to one. SMARTER is an improvement of the existing SMART method [100]. The idea of the improved version is to use the centroid method so that the weight of  $i$ -th ranked criteria is:

$$w_i = \frac{1}{n} \sum_{k=1}^n \frac{1}{k}, \quad (4.15)$$

where  $n$  is the number of criteria.

In the pair-wise comparison method, participants are presented a worksheet and are asked to compare the importance of two criteria at a time. Then the relative importance is scored. The scales can be various. The results are consolidated by adding up the scores obtained by each criterion when preferred to the criteria it is compared with. The results are then normalized to a total of 1. This weighting method provides a framework for comparing each criterion against all others and helps to show the difference in importance between criteria. However, it does not allow to check the consistency of participants' preferences, especially, their transitivity.

The Analytic Hierarchy Process (AHP) method is based on the pair-wise comparison method for determining the weights for each criterion [101]. In this process, the decision

maker carries out simple pairwise comparison judgments and based on the constructed matrix of pairwise comparison, criteria weights can be calculated. The degree of consistency achieved in the pair-wise comparison is measured by a consistency ratio indicating whether the comparison made is sound. The AHP method is described thoroughly in CHAPTER 5, Section 5.4.1.

#### 4.4.2. Objective weighting methods

The objective weighting method elicits the criteria weights using the measurement data and information and reflects the difference degree [97].

One of the used objective weighting methods is entropy method. The entropy shows how much the criteria reflects the information of system and what is the extent of the uncertainty of criteria. A vector of  $x_j = (x_{1j}, x_{2j}, \dots, x_{mj})$  characterizes the set  $X$  in terms of the of  $j$ -th criteria defined as following:

$$X_j = \sum_{i=1}^m x_{ij} \quad , j = 1, 2, \dots, n \quad (4.16)$$

Hence, the decision-making problem can be formalized into matrix as shown in Equation (4.7). In the entropy weighting technique, the entropy-based difference of the  $j$ -th attribute (criterion) between alternatives is viewed as the foundation to determine the weight of attributes. When the difference of two alternatives about the  $j$ -th attribute is small, then this attribute does not provide sufficient information to rank or distinguish the two alternatives [102]. Therefore, the less is the difference, the smaller is the weight. The normalized entropy measure of  $j$ -th criterion is expressed then as:

$$e_j = -\frac{1}{\ln m} \sum_{i=1}^m \frac{x_{ij}}{X_j} \ln \frac{x_{ij}}{X_j} \quad , j = 1, 2, \dots, n \quad (4.16)$$

And the weight can be calculated as follows:

$$w_j = \frac{1 - e_j}{\sum_{j=1}^n (1 - e_j)} \quad (4.17)$$

The Technique for Order Preference by Similarity to Ideal Solution (TOPSIS) is based upon the concept that the chosen alternative should have the shortest distance from the ideal solution and the farthest from the negative-ideal solution [103] in geometrical sense. The weighted distance between alternative  $A_i$  and the ideal solution  $A^*$  is defined as follows:



$$h_i = \sum_{j=1}^n w_j^2 (x_{ij} - x_j^*)^2 \quad (4.18)$$

The following optimal model is solved, and the weights can be elicited:

$$\left. \begin{aligned} \min \sum_{i=1}^m h_i &= \sum_{i=1}^m \sum_{j=1}^n w_j^2 (x_{ij} - x_j^*)^2 \\ \text{s. t. } \sum_{j=1}^n w_j &= 1, \quad w_j \geq 0 \end{aligned} \right\} \quad (4.19)$$

#### 4.4.3. Combination weighting methods

The methods have two basic combinations the multiplication synthesis and additive synthesis. The principle of multiplication synthesis is expressed as:

$$w_j = \frac{w_{1j} \cdot w_{2j}}{\sum_{j=1}^n w_{1j} \cdot w_{2j}}, \quad (4.20)$$

where  $w_{1j}$  and  $w_{2j}$  are subjective and objective weights, and  $w_j$  the combination weight of the  $j$ -th criterion.

The principle of additive synthesis is expressed as:

$$w_j = k \cdot w_{1j} + (1 - k) \cdot w_{2j}, \quad k \geq 0, \quad (4.21)$$

where  $k$  is the linear combination coefficient.

## 4.5. RANKING METHODS

Once the weights of the criteria have been determined and calculated, the determination of the preference orders of alternatives can be done. Different MCDM methods can be used to get this ranking order of the alternatives. The ranking methods can be classified in four main categories elementary, unique synthesizing, outranking and other methods. Main MCDM ranking methods found in literature are summarized in Table 4.2.

Table 4.2. Most common MCDM methods used for ranking of the criteria (summarized based on [97])

Category	MCDM (ranking) method
Elementary	Weighted sum method (WSM)
	Weighted product method (WPM)
Unique synthesizing	Analytic Hierarchy Process (AHP)
	Multi-attribute utility theory (MAUT)
	Fuzzy set methodology
Outranking	Elimination and Choice Expressing Reality (ELECTRE)
	Preference Ranking Organization Method for Enrichment Evaluation (PROMETHEE)
Other	Više Kriterijumska Optimizacija Kompromisno Rešenje (VIKOR)

#### 4.5.1. Elementary methods

Weighted sum method (WSM) is very commonly used approach, especially in decision-making processes for sustainable energy systems. The score, i.e., final grade of an  $i$ -th alternative  $S_i$  is calculated as:

$$S_i = \sum_{j=1}^n w_j \cdot x_{ij} \quad , \quad i = 1, 2, \dots, m \quad (4.22)$$

Where  $w_j$  is the weight associated with the  $j$ -th criterion (using one of the above-mentioned weighting criteria), and  $x_{ij}$  is the performance of  $i$ -th alternative on  $j$ -th criterion. The resulting cardinal scores for each alternative can be used to rank, screen, or choose an alternative. The best alternative is the one whose score is the maximum.

Similar to the WSM method is the weighted product method (WPM). However, instead of addition there is a multiplication in the calculation of the final score of an alternative. Therefore, the score of an  $i$ -th alternative  $S_i$  is calculated as:

$$S_i = \prod_{j=1}^n w_j \cdot x_{ij} \quad , \quad i = 1, 2, \dots, m \quad (4.22)$$

Naturally, the alternative having the maximum score is the best scheme. Because of the exponent property, this method requires all ratings be greater than 1. to meet this requirement. Alternative scores obtained by the weighted product method do not have a numerical upper bound.

#### 4.5.2. Unique synthesizing criteria methods

Analytic Hierarchy Process (AHP) is widely used ranking method in various domains such as social, economic, industrial, and energy systems. The method calculates ratio-scaled

importance of alternatives via pair-wise comparison of evaluation criteria and alternatives. It basically involves decomposing a complex decision problem into a hierarchical structure with the goal at the top of the hierarchy, and the decision alternatives at the bottom of the hierarchy with different levels of criteria and sub-criteria in between. As shown in Section 4.4.1. the AHP method is commonly used to obtain weight of the criteria. After obtaining the weights, each performance at the given level is then multiplied with its weight and then the weighted performances are summed to get the score at a higher level. The procedure is repeated upward for each hierarchy, until the top of the hierarchy is reached. The overall weights with respect to goal for each decision alternative is then obtained. The alternative with the highest score is the best alternative. The AHP method is described in more details in CHAPTER 5, Section 5.4.1.

TOPSIS as a weighting method is described in Section 4.4.1. Like the AHP method, it can also be used as a ranking method in the third stage of the MCDM process (as depicted in Table 4.1) The principle of TOPSIS is simple in terms that the selected best alternative should have the shortest distance from the positive ideal solution in geometrical sense while it has the longest distance from the negative solution. The method assumes that each criteria has a monotonically increasing or decreasing utility. Therefore, it makes it easy to locate the ideal and negative ideal solutions. The positive distance between alternative  $A_i$  and the ideal solution  $A^*$  is defined as:

$$s_i^+ = \sqrt{\sum_{j=1}^n (x_{ij} - x_j^+)^2}, \quad i = 1, 2, \dots, m, \quad (4.23)$$

where  $x_j^+$  is the  $j$ -th criterion's performance of the ideal solution  $A^*$ .

The negative distance is calculated as:

$$s_i^- = \sqrt{\sum_{j=1}^n (x_{ij} - x_j^-)^2}, \quad i = 1, 2, \dots, m, \quad (4.24)$$

where  $x_j^-$  is the  $j$ -th criterion's performance of the negative ideal solution  $A^-$ .

Finally, the relative closeness degree of  $A_i$  and  $A^*$  is defined as:

$$r_i = \frac{s_i^-}{s_i^- + s_i^+} \quad (4.25)$$

The best alternative is one that has the maximum closeness degree and has the shortest distance to the ideal solution.

Multi-attribute utility theory (MAUT) is a systematic method for identifying and analysing several variables to provide a common basis for decision making. It attempts to maximize a decision maker's utility or preference presented by a function that maps an object measured on an absolute scale into the decision maker's utility or value relations. Therefore, a key step in this method is characterizing a multi attribute utility function [104]. To do this it is necessary to identify single attribute utility functions and their weights. It is assumed that the utility functions are monotonic and that sometimes the decision-makers are risk averse. Formulating a multi attribute utility function provides the possibility of computing each alternative's final value.

The classic MCDM methods generally assume that all criteria and their respective weights are expressed in crisp values. However, due to the availability and uncertainty of information as well as the vagueness of human feelings and recognition it can sometime be difficult to provide exact numerical values to the criteria. Hence, the weights of the criteria can be expressed in linguistic terms by the decision makers. These linguistic evaluations are transformed into fuzzy numbers and using those fuzzy numbers instead of real numbers [105]. Considering the fuzziness provides less risky decisions.

#### 4.5.3. Outranking methods

The foundation of the outranking methods is the construction and the exploitation of an outranking relation [106]. An outranking relation is a binary relation  $S$  defined on the set of alternatives  $A$  such that for any pair of alternatives  $(A_i, A_k) \in A \times A$ :  $A_i S A_k$  if, given what is known about the preferences of the decision maker, the quality of the evaluations of the alternatives and the nature of the problem under consideration, there are sufficient arguments to state that the alternative  $A_i$  is at least as good as the alternative  $A_k$ , while at the same time no strong reason exists to refuse this statement [97].

Elimination and Choice Expressing Reality (ELECTRE) method proposed in 1966 [107]. The method underwent several updates. Hence, up to now, ELECTRE includes ELECTRE I, II, III, IV, TRI, and some improved ELECTRE methods. For most ELECTRE methods, there are two main stages: (i) the construction of the outranking relations and (ii) the exploitation of these relations to get the final ranking of the alternative. Different ELECTRE methods differ in how they define the outranking relations between alternatives and how they apply these relations to get the final ranking of the alternatives. ELECTRE methods use concordance,

discordance indexes and threshold values to analyse the outranking relations among the alternatives. The concordance index for a pair of alternatives  $A_i$  and  $A_k$  measures the strength of the hypothesis that alternative  $A_i$  is at least as good as alternative  $A_k$ . There are no unique measures of concordance. In ELECTRE II for example, the concordance index  $C(A_i, A_k)$  for each pair of alternatives  $(A_i, A_k)$  is defined as follows:

$$C(A_i, A_k) = \frac{\sum_{j \in Q(A_i, A_k)} w_j}{\sum_{j=1}^n w_j}, \quad (4.26)$$

where  $Q(A_i, A_k)$  is the set of criteria for which  $A_i$  is at least as good as  $A_k$  and  $w_j$  is the weight of the  $j$ -th criterion. The discordance index  $D(A_i, A_k)$  is defined as follows:

$$D(A_i, A_k) = \frac{\max_{j \in Q^-(A_i, A_k)} |x_{A_i, j} - x_{A_k, j}|}{\max_{j=1}^n |x_{A_i, j} - x_{A_k, j}|}, \quad (4.27)$$

where  $Q^-(A_i, A_k)$  is the set of criteria for which  $A_i$  is worse than  $A_k$ ,  $x_{A_i, j}$  and  $x_{A_k, j}$  represent the performances of alternatives  $A_i$  and  $A_k$  for the  $j$ -th criterion, and  $n$  is the number of criteria. The formula can be only used when the scores for different criteria are comparable. After computing the concordance and discordance indices for each pair of alternatives, the graphs for strong and weak relationship can be painted respectively by comparing these indices with the threshold values. Then these graphs are employed to determine the descending and ascending order of alternatives [97]. Accounting for the intersection of the descending and ascending orders, the final order of the alternatives can be determined.

Preference Ranking Organization Method for Enrichment Evaluation (PROMETHEE) uses the outranking principle to rank the alternatives but is also characterized with ease of use and decreased complexity. Compared to ELECTRE the indifference and preference thresholds are considered constant which is a simplification but also restriction [108]. The principle is the construction, and the exploitation of a valued outranking relation  $\pi$ , also called a preference index. Two complete preorders can be obtained by ranking the alternatives according to their incoming flow and their outgoing flow. The intersection of these two preorders yields the partial preorder of PROMETHEE I method where incomparability is allowed. The ranking of the alternatives according to their net flow yields the complete preorder of PROMETHEE II. The method uses the pair-wise comparison of alternatives to rank them with respect to a number of criteria. PROMETHEE introduces the preference functions to measure the difference between two alternatives for any criteria, which is different from ELECTRE method which only pays attention to the preference level between alternatives when ranking them. Six general preference functions are identified to cover most

of the cases [97], [98]: usual criterion, quasi-criterion, criterion with linear preference, level-criterion, criterion with linear preference, and Gaussian criterion. Multi-criteria preference index for a pair of alternatives  $A_i$  and  $A_k$  is defined as:

$$\pi(A_i, A_k) = \frac{\sum_{j=1}^n w_j \cdot p_j(A_i, A_k)}{\sum_{j=1}^n w_j}, \quad (4.28)$$

where  $p_j(A_i, A_k)$  represents the preference function for alternatives  $A_i$  and  $A_k$ . Now, the incoming flow (Equation 4.28) and outgoing flow (Equation 4.29) are calculated as:

$$\phi^+(A_i) = \sum_{k=1}^m \pi(A_i, A_k) \quad (4.28)$$

$$\phi^-(A_i) = \sum_{k=1}^m \pi(A_k, A_i) \quad (4.29)$$

$$k = 1, 2, \dots, m \quad (4.30)$$

Where  $m$  is the number of possible alternatives. In PROMETHEE methods, the higher the leaving flow and the lower the entering flow, the better the alternative [109]. Finally, the net flow is equal to the difference of incoming flow and outgoing flow:

$$\phi(A_i) = \phi^+(A_i) - \phi^-(A_i) \quad (4.31)$$

The outgoing and ingoing flows induce the following preorders on alternatives  $(A_k, A_i) \in A$ :

$$\begin{cases} A_i P^+ A_k & \text{iff } \phi^+(A_i) > \phi^+(A_k) \\ A_i I^+ A_k & \text{iff } \phi^+(A_i) = \phi^+(A_k) \end{cases} \quad (4.32)$$

$$\begin{cases} A_i P^- A_k & \text{iff } \phi^-(A_i) < \phi^-(A_k) \\ A_i I^- A_k & \text{iff } \phi^-(A_i) = \phi^-(A_k) \end{cases} \quad (4.33)$$

Where  $P$  and  $I$  represent preference and indifference, respectively. Furthermore, after obtaining all net flows of alternatives, the alternative having maximum net flow is considered as the best.

#### 4.5.4. Other methods

Multiple criteria decision making (MCDM) is frequently used to deal with conflict problems. Furthermore, practical problems are often characterized by several non-commensurable and conflicting (competing) criteria, and there may be no solution satisfying all criteria simultaneously. Therefore, using MCDM, a compromise solution for a problem with conflicting criteria can be determined, which can help the decision makers to improve the problems for achieving the final decision. Yu (1973) and Zeleny (1982) proposed the foundation for compromise solutions. The compromise solution is a feasible solution closest

to the ideal/aspired level, compromise meaning an agreement established by mutual concessions.

The Više Kriterijumska Optimizacija Kompromisno Rešenje (VIKOR) is one of the compromise methods developed by [110]. The VIKOR method provides the maximum group utility for the majority and minimum of an individual regret for the opponent. It introduced the multi-criteria ranking index based on the particular measure of closeness to the ideal solution [109]. Furthermore, this method does not depend on the evaluation unit of a criterion function. It focuses on ranking, improving, and selecting from a set of alternatives in the presence of conflicting criteria to help the decision makers to relax the trade-offs for reaching the aspired levels [111]. Detailed description of VIKOR method is provided in CHAPTER 5, Section 5.4.2.

#### 4.6. COMPARISON OF MOST COMMONLY USED MCDM METHODS

Mostly used MCDM methods in terms of weighting and ranking of the criteria and alternatives that represent a certain complex MCDM problem are presented in Sections 4.4 and 4.5. Some of them are used more than others due to simplicity in procedure or specificities that can sufficiently enough deal with specific MCDM problems. However, no single MCDM model can be ranked as best or worst. Every method has its own strengths and weaknesses depending upon its application in all the consequence and objectives of planning. Some of the strengths and weaknesses of most frequently used MCDM methods (available in public domain) are shown in Table 4.3 and Table 4.4.

Table 4.3. Mostly used MCDM methods and their strengths and weaknesses (summarized based on [91])

Method	Strengths	Weaknesses
WSM	<ol style="list-style-type: none"> <li>1. Simple computation.</li> <li>2. Suitable for single dimension problems.</li> </ol>	<ol style="list-style-type: none"> <li>1. Only a basic estimate of one's tendency function.</li> <li>2. Not able to integrate multiple preferences.</li> </ol>
WPM	<ol style="list-style-type: none"> <li>1. Labelled to solve decision problems involving criteria of same type.</li> <li>2. Uses relative values and hence eliminates the problem of homogeneity.</li> </ol>	<ol style="list-style-type: none"> <li>1. Leads to undesirable results as it prioritises or deprioritises the alternative far from average.</li> </ol>
AHP	<ol style="list-style-type: none"> <li>1. It is adaptable.</li> <li>2. Ease of use as it does not involve complex mathematics.</li> <li>3. Based on hierarchical structure and thus each criterion can be better focussed and transparent.</li> </ol>	<ol style="list-style-type: none"> <li>1. Interdependency between objectives and alternatives leads to hazardous results.</li> <li>2. Demands data collected based on experience.</li> <li>3. Involvement of more decision maker can make the problem more complicate while assigning weights.</li> </ol>
TOPSIS	<ol style="list-style-type: none"> <li>1. Uses fundamental ranking.</li> <li>2. Makes full use of allocated information.</li> <li>3. The information need not be independent.</li> </ol>	<ol style="list-style-type: none"> <li>1. Basically, it works based on Euclidian distance and so doesn't consider any difference between negative and positive values.</li> <li>2. The attribute values should be monotonically increasing or decreasing.</li> </ol>

Table 4.4. Mostly used MCDM methods and their strengths and weaknesses (summarized based on [91]) (*continued*)

<b>Method</b>	<b>Strengths</b>	<b>Weaknesses</b>
MAUT	<ol style="list-style-type: none"> <li>1. Accounts for any difference in any criteria.</li> <li>2. Simultaneously computes preference order for all alternatives.</li> <li>3. Dynamically updates value changes due to any impact.</li> </ol>	<ol style="list-style-type: none"> <li>1. Difficult to have precise input from decision maker.</li> <li>2. Outcome of the decision criteria is uncertain.</li> </ol>
ELECTRE	<ol style="list-style-type: none"> <li>1. Deals with both quantitative and qualitative features of criteria.</li> <li>2. Deals with heterogeneous scales.</li> <li>3. Final results are validated with reasons.</li> </ol>	<ol style="list-style-type: none"> <li>1. Less versatile.</li> <li>2. Demands good understanding of objective specially when dealing with quantitative features.</li> </ol>
PROMETHEE	<ol style="list-style-type: none"> <li>1. Deals with qualitative and quantitative and qualitative information.</li> <li>2. Incorporates uncertain and fuzzy information.</li> <li>3. Involves group level decision.</li> </ol>	<ol style="list-style-type: none"> <li>1. Doesn't structure the objective properly.</li> <li>2. Depends on the decision maker to assign weight.</li> <li>3. Complicated and therefore the users are limited to experts.</li> </ol>
VIKOR	<ol style="list-style-type: none"> <li>1. Generally, an updated version of TOPSIS.</li> <li>2. Calculates ration of positive and negative ideal solution thereby removing the impact.</li> </ol>	<ol style="list-style-type: none"> <li>1 Difficulty when conflicting situation arises.</li> <li>2 Need of modification while dealing with some concise data as it becomes difficult to model a real time model.</li> </ol>



## MCDM METHODOLOGY

THIS CHAPTER presents the developed integrated multi-criteria decision-making (MCDM) methodology. Fundamentally, in each decision-making process there are influencing criteria (factors) that have impact on the decision. Therefore, it is crucial to identify and define the influencing criteria related to the investments in the EGS energy projects in the first stage of methodology development. Based on the extensive literature review and expertise gained, presented also in this Chapter, the main criteria have been identified and selected using the Delphi method as criteria selecting method. Each of identified criteria is defined separately. Some of the criteria are quantitative and some qualitative in nature. Furthermore, each criterion is measured in different units. Consequently, to be able to evaluate EGS projects on a larger scale and in a unified way, the method for standardized evaluation of defined influencing criteria was developed. Additionally, not all criteria have the same impact on the overall goal of the decision-making problem. Therefore, after grading of all criteria, the relative importance of each criterion in decision-making needs to be associated with each criterion, i.e., certain weights need to be assigned to each criterion. This reflects decision-makers preferences and is therefore greatly dependant on the background expertise and employment position of the decision-maker. Additionally, aside from different criteria which are used to deconstruct complex decision-making problem, there are always various possible alternatives to achieve the goal of the decision-making problem. Among those alternatives there is a gradation in terms of optimality. In other words, a certain ranking order of possible alternatives exists. Based on this, an integrated MCDM methodology was developed and presented in this Chapter which includes method for standardized grading of each criterion (Section 5.3) and integrated weighting and ranking method (Section 5.4).

### 5.1. PREAMBLE

Energy planning using multi-criteria analysis has attracted the attention of decision makers for a long time. The methods can provide solutions to increasing complex energy management problems. Traditional single criteria decision making is normally aimed at maximization of benefits with minimization of costs. During 1970s, energy planning was mainly focused on energy models which aimed at exploring the energy-economy relationship established in

energy sector. Single criteria approach for identifying the most efficient energy supply options at a low cost was popular. Additionally, MCDM research in the 1970's emphasized the theoretical foundations of multi-objective mathematical programming and the development of procedures and algorithms for solving such problems - especially multiple objective linear programming problems and discrete problems. Many ideas originated from the theory of mathematical programming. The algorithms were programmed for mainframe computers (often in FORTRAN) and were used mainly for illustrative purposes. The models of energy systems were often of a prototypical nature, lacked user-friendly interfaces (appealing visuals) [112]. In the 1980s, the above-mentioned decision framework has been slightly modified due to increasing awareness about environmental impact. The need to include environmental and societal impacts and considerations in energy planning resulted in the increasing use of multi-criteria approaches [113]. Hence, the role of different actors in decision-making became important. Therefore, the number of different MCDM methods has been growing ever since the 1960s/1970s because the spectrum of applications of MCDM methods has been constantly expanding. Namely, a decision-maker is required to choose among quantifiable or non-quantifiable and multiple criteria. The objectives are usually conflicting and therefore, the solution is highly dependent on the preferences of the decision-maker and a certain level of compromise is required. In most of the cases, different groups of decision-makers are involved in the process. Each group brings along different criteria and points of view, which must be resolved within a framework of mutual understanding and compromise.

Energy related projects, especially renewable energy sources (RES) projects (which includes geothermal energy projects and EGS), involves numerous issues and uncertainties during phase of planning of their commission. For example, it is hard to accomplish balanced techno-socio-economic evaluation due to many conflicting criteria and their interactions. Therefore, in practice, rational decision making in energy projects is usually very difficult and complex. In this context multi-criteria decision analysis (MCDA) can be of great importance. It represents operational evaluation and decision support approach suitable for addressing complex problems featuring high uncertainty, conflicting objectives, different forms of data and information, and multi-interests from user perspectives.

There are some practical requirements for an MCDM method to be used in RES projects planning and assessment. They include [95]:

- The ease of use;
- The ability to support a large number of decision makers;

- The capacity to handle many criteria and alternatives;
- The ability to handle inaccurate or uncertain criteria (e.g., in RES projects, some of the information required is rather qualitative and other is just uncertain);
- Reasonable requirements on time and money; and
- The direct interpretation of parameters.

It is very difficult for any technique to satisfy concurrently all the previously discussed requirements. Nevertheless, the large number of decision-makers, alternatives, and criteria in public (renewable) energy and environmental problems is usually the norm. The ease of use is also an important attribute for an MCDM method to be used in RES decision making. Decision-makers who are going to use the method are sometimes not experts with knowledge required for comprehensive analysis of the decision-making problem related to the RES project planning and developing. They may feel being manipulated by a “black box” methodology when they are unable to understand the way that the used methods operate.

#### 5.1.1. Criteria in energy projects planning

As seen in the available literature, energy planning is widely being evaluated by means of technical, economic, environmental, and institutional indicators/criteria, using various MCDM methods. MCDM analysis is being used in variety of energy issues including energy planning and selection [114]–[119], energy exploitation [120], [121], energy resource allocation [122]–[125], energy policy [96], [126], [127], and others [128].

According to the author in [129], in order for the indicators to be useful in the decision-making process, they have to contain some essential features, listed in Table 5.1.

Table 5.1. Important features of the indicators/criteria (summarized according to [129])

<b>Distinguishing features of indicators</b>	<b>Remarks</b>
Simple to understand and apply	No method will be used in practice unless the potential user feels comfortable and can understand the structure of the method as well as each indicator included.
Transparent and inter-subjective	The underlying data have to be easily available and realistically traceable, as well as the definition of the indicators.
Robust	The indicators shall be formulated clearly enough to be replicable in their application.
Comprehensive	The predefined set of indicators need to cover all major aspects of sustainable development.
Fair	The indicators have to be fair in respect of comparing projects in different areas.

The commonly used criteria to evaluate the energy supply systems is in the literature are mainly divided into four aspects: technical, economic, environmental, and societal criteria as shown in Table 5.2.

Table 5.2. The typical evaluation criteria of the energy system (summarized according to [97])

<b>Aspects</b>	<b>Criterion</b>
Technical	Efficiency
	Exergy efficiency
	Primary energy ratio
	Maturity
	Others
Economic	Investment cost
	Operation and maintenance cost
	Fuel cost
	Net present value (NPV)
	Payback period
Environmental	Others
	CO <sub>2</sub> emission
	Particles emission
	Land use
	Noise
Societal	Others
	Social acceptability
	Job creation
	Social benefits
	Others

5.1.2. Geothermal energy (EGS) projects evaluation approach

Geothermal projects, especially EGS projects present complex investments. Namely, EGS projects are highly site specific. When assessing the potential geothermal project, either as a greenfield or brownfield project, with respect to the sustainability, different aspects should be considered. The sustainability of the geothermal project deals with three main aspects: technology feasibility; environmental and societal impact; and economic feasibility. Therefore, a multidisciplinary approach in assessing sustainable geothermal project is needed. This approach needs to consider subsurface phenomena related to the reservoir and above surface phenomena related to technology used, among which are the extraction technology, power plant type and geothermal brine gathering system, end users’ specific needs for heat or electricity or both, and environment which is in close relationship with end-users. All these aspects highly influence the economics of such projects in terms of capital costs and operating and maintenance (O&M) costs (Figure 5.1).

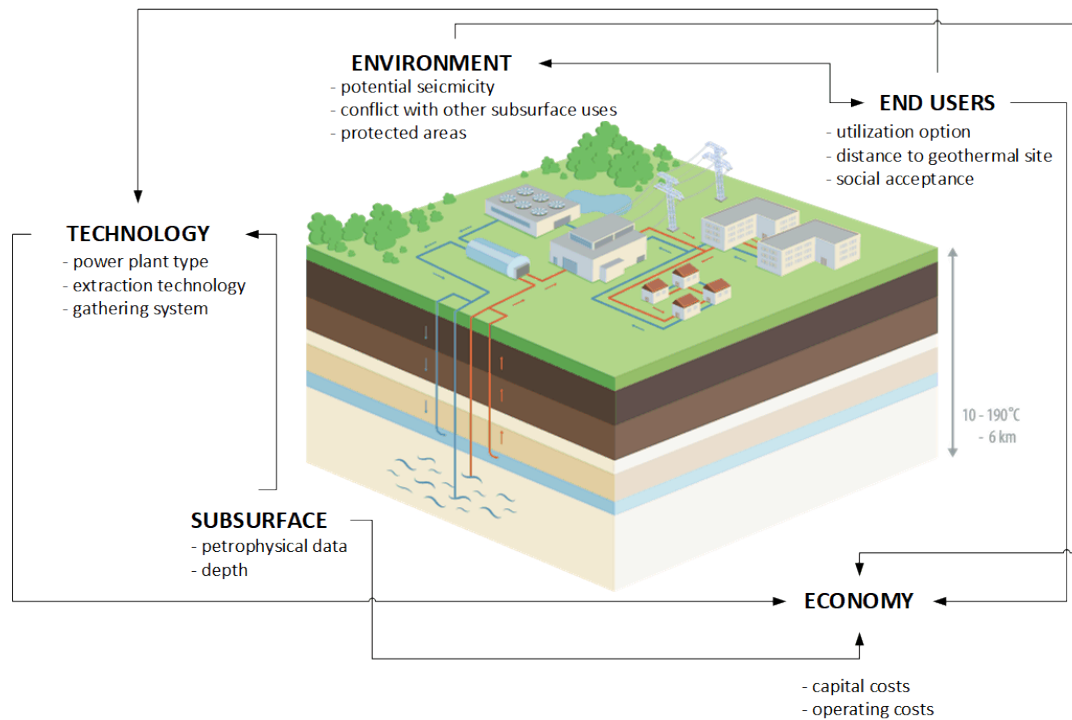

Figure 5.1. Geothermal project assessment aspects

Due to the multi-dimensionality of the sustainable energy projects and complexity of socio-environmental-economic systems, as shown also in Figure 5.1, the multi-criteria decision making (MCDM) methods have become increasingly popular in decision-making processes related to sustainable energy. Particularly, the EGS project related decision making must take into account complex and holistic set of influencing phenomena including technical, economic, geological, societal and environmental impacts.

### 5.1.3. Decision-making process associated to geothermal energy projects

Decision making in geothermal energy projects requires consideration of geological, technical, economic, environmental, and societal impacts (as shown in Figure 5.1). This is often a very complex process that is susceptible to different preferences of involved actors with different points of view. When considering geothermal project those actors may include group of individuals, administration authorities on local or regional level, local communities, academic institutions, environmental groups, and governmental bodies that through their evaluation systems and priorities have interests at stake and indirectly or directly influence the decision-making process. Consequently, they are altering the way in which the final decision regarding EGS project will be made. In that regard, geothermal energy projects are faced with low public awareness of the possibilities and advantages of geothermal energy usage in both power and heating/cooling sectors. All these aspects somehow dictate the decision-making

process which encompasses complex interaction between techno-economic, socio-environmental, and geophysical factors.

The decision-making around geothermal energy projects presents multidimensional problem that encompasses complex interaction between socio-environmental, techno-economic, and geophysical factors. After literature review, presented problems and solutions could be classified into four homogeneous problem classes as shown in Table 5.3. Those that did not fit into any of four problem classes are characterized as ‘other’. The problem classes include source selection, geothermal potential, location selection, and technologies performance. Namely, various studies have been conducted to select best renewable energy source for the region of the study, and geothermal energy is compared to other sources. In [5] various technical characteristics, resource availability, socio-economic, environmental, political, legal and organizational aspects were incorporated in the Analytic Hierarchy Process (AHP) model for evaluating and prioritizing different power plants, including geothermal. In [6] a comparative analysis of ranking renewable energy sources for electricity generation in Taiwan, using four different multi-criteria decision-making (MCDM) methods, was presented. The geothermal energy resulted as fifth best option and additionally it was demonstrated that each MCDM method has its advantages and disadvantages, and neither method is dominating other methods. Geothermal resource potential areas are mostly assessed using different GIS-based models and methods [7]–[12] based on main geological and geophysical data such as fault distribution, Bouguer gravity anomaly, temperatures at different depths, etc. Theoretical, technical, and economic potential of EGS systems globally [13] and in Europe [14], [15], and of combined heat and power production from hydrothermal geothermal resources in Germany [31], were also studied. The study in [24] investigated five geothermal resource target areas in the Sonyuan region of China considering only geothermal evaluation indicators that are directly related to geothermal resources, omitting thereby evaluation indicators such as land use or environmental impact.

Determining the exact position where geothermal plant will be installed is an important step that precedes the technical development phase of the project. Possible EGS plant locations have been investigated on both global [16], [17] and regional/local [18], [19] scale. Effectiveness of an EGS power plant depends on the suitability of an area to geothermal energy extraction and conversion, which is a complex and unknown combination of many geological, environmental, and societal factors. Additionally, as indicated in [20], siting EGS in rural and urban areas involves trading off benefits of sold heat, avoided CO<sub>2</sub> emissions, and induced seismicity risk. Namely, in remote areas the induced seismicity risk is minimal, but

EGS heat cannot be purposefully used for residential district heating. On the other hand, in urban areas, the heat can be sold, but EGS project poses higher risk of induced seismicity.

Technology selection and geothermal facility performance assessment are essential for an investment to be successful. Additionally, to bypass exploration and drilling risks, the co-production and retrofitting of mature and abandoned oil wells presents a direction worth further research [130]. The study in [25] aimed at demonstrating potential of UK's mature hydrocarbon fields to provide geothermal energy from co-produced water. ORC systems showed significant potential, without interfering with the oil production process, but also direct heating and combined heat and power production scenarios were potentially viable options. The study in [21] proposed a selection matrix to choose between two different technologies, the traditional doublet and wellbore heat exchanger, in order to convert a hydrocarbons fields into a geothermal one for direct usage of heat. The two proposed technologies are compared based on the defined set of nine indexes, which include technological indexes, environmental indexes, and cost indexes. Each index is, based on the defined thresholds for each index, evaluated with a value between 1 and 0, with 0 being unfavourable and 1 highly favourable. An updated version of this selection matrix was proposed in [22] aiming to provide an evaluation instrument of two different geothermal plants, as well as to highlight dependence of the results on the weights that the decision maker assigns to each index. This decision making matrix served as basis and was expanded in [23] to provide wider applicability, in other words to enable assessment of the geothermal potential of mature hydrocarbon fields in more broader context.

Some revised papers do not fit into the problem classes above, such as [28] where the Ex-Ante and Post-Ante criteria are used to evaluate the economic performance of the system based on the Net Present Value (NPV), Levelized Cost of Heat (LCOH), and Expected Monetary Value (EMV). As demonstrated, the presented techno-economic model enables a comprehensive understanding of the interactions between economic and technical uncertainties. In this category also fall the papers that apply Life-Cycle Assessment (LCA) methods. In [26] a comprehensive LCA on geothermal power production from EGS low-temperature reservoirs was performed and the results indicate that the environmental impacts are highly influenced by the geological conditions that can be obtained at a specific geothermal site. The study in [27] quantifies and analyses life cycle greenhouse gas (GHG) emissions from five different scenarios, that are developed respecting LCA methodology, comprising a heat production plant, power plants and cogeneration plants. Moreover, in [30] a societal multi-criteria evaluation is proposed aiming to explore the different legitimate

perspectives of the actors involved. The criteria reflect economic considerations, societal aspects and environmental concerns. Additionally, sustainable energy planning is crucial. The work presented in [29] proposes a new decision-support framework that takes into account all three pillars of sustainable development: environment, economics and society. The indicators used in the MCDM analysis belongs to the mentioned groups and was firstly preformed assuming equal importance for all the sustainability indicators. Additionally, the choice of the most sustainable options was discussed related to the change in assumed importance or priority of sustainable indicators.

Table 5.3. Identified problem classes encountered in literature survey

<b>Problem class</b>	<b>Definition</b>	<b>References</b>	<b>Addressed with methodology proposed in the thesis</b>
Source selection	Decision-making process that focuses on selecting a better energy source or a mix of sources	[5], [6]	no
Geothermal potential	Decision-making that aims to evaluate the geothermal potential	GIS-based [7]–[12] other [13]–[15], [24], [31]	yes
Location	Decision-making process that aims to select better location of energy generation from a source	[16]–[20]	yes
Technologies performance	Decision-making that aims to select the better technology	[21]–[23], [25]	yes
Other	-	[26]–[30]	yes

Based on the literature, it can be observed that various approaches can be applied when considering decision-making process in scope of investment in EGS projects and geothermal energy in general. However, conclusion related to the surveyed approaches is that they either concentrate on geological and geophysical criteria [8]–[13], [15], [18], [19], [24], or on technological criteria [25], or on environmental criteria [26], [27], or some combination of techno-economic [28], environmental [29] and societal criteria [20]–[22], [30]. Considering geological but also techno-economic [14], [31], and some environmental and societal criteria is found in [23]. However, to this thesis author’s knowledge, no methodology considering main influencing factors from all five main criteria group (geological, technological, economic, environmental, and societal) has been proposed and studied.



## 5.2. IDENTIFICATION AND DEFINITION OF INFLUENCING CRITERIA RELATED TO INVESTMENTS IN EGS ENERGY PROJECTS

To generate electricity and/or heat energy from the geothermal heat energy, it is necessary to find a proper location where the favourable conditions are present. When the location is determined, it should be tested and assessed for a long-term utilization. Various exploitation technologies differ based on the geothermal gradient, amount of fluid, reservoir temperature, pressure, the hot steam-water ratio, corrosion hazard, etc. Since the more abundant low-enthalpy sites and low-temperature and low-permeable bedrock represent 70% of European geothermal potential exploitable only by EGS technology, the next Section present an overview of various issues and influencing factors of EGS implementation and integration in existing power and heating systems, i.e., investment in EGS energy projects.

### 5.2.1. Overview of many influencing factors on EGS implementation and integration

To conduct a more comprehensive examination of subsurface conditions, geophysical exploration and investigation can be employed for the measurement of physical properties. These measurements are sensitive to the temperature, fluid content of the rocks and rock structures that could influence the geothermal field. With these measurements on disposal, it is possible to determine very important parameters enabling better determination of the geothermal system. The parameters whose high values indicate a promising condition of the subsurface are geothermal gradient and thermal conductivity [131]. Except for these two factors, there are multiple others which could indicate a promising location for installing EGS facility. Comprehensive lists of identified influencing factors related to the investment in EGS energy projects are listed in Table 5.4 and Table 5.5. It should be stressed out that most of these influencing factors have already established and well tested practical measurement and gathering methods, but for the sake of comprehensives all identified influencing factors are listed in the tables. The influencing factors are categorized in two main groups: surface and subsurface which are afterwards separated into sub-groups. The sub-groups are reservoir properties, geothermal fluid, working fluid features, the environmental impacts, socio-economic influences, technological characteristics, and legislative framework. Additionally, the factors are divided into *parameters* (non-bold) and *variables* (in bold). Parameters are assumed to be fixed for specific location while variables are those factors that can be by specific solutions and technologies used during development phase, and also during operational phase of an EGS project.

Reservoir and geothermal fluid properties groups contain all important factors that in some extent influence the potential site development. The starting point of any geothermal project is to determine the properties of the potential reservoir to which the production and injection wells would be drilled. The main reservoir properties are: the existence of fractures and faults, existence of aquifers and aquitards, geothermal gradient, permeability, porosity, density, thermal conductivity, etc. Based on the data gathered for those reservoir rock properties, it is decided whether the targeted reservoir represent a satisfying probability for the usage and later production, or that it should be enhanced by applying different stimulation techniques, or, in worst case, it presents too extensive investment which rules it out of considerations. Namely, the upfront costs of greenfield geothermal projects are substantially high (e.g., drilling requires around 15% of the total investment costs to be spent upfront, with no certainty of return). This could be omitted by using abandoned or mature oil and gas fields [21], [23], [25], [130], [132]–[134]. Such fields with existing subsurface infrastructure represent a good solution even if the enhancement techniques must be applied because they can provide yearlong production data.

Geothermal fluid flow is caused by the pressure gradient, i.e., the pressure difference between reservoir and the dynamic flowing pressure. However, in cases when natural flow is not sufficient for the heat extraction, the injection pumps are installed in the injection wells (e.g., electric submersible pumps, ESP) or at the surface. Geothermal fluid, as a main part of the EGS, is a carrier of the subsurface/reservoir chemical content which can affect the technology and environment even in if small amount of ppm is present. For example, the fluid that contains a huge amount of H<sub>2</sub>S, chemical salt (NaCl) and silica (SiO<sub>2</sub>) can cause corrosion and precipitation and consequently cause severe damage to the pipelines and the entire geothermal fluid gathering system. Additionally, during the injection of geothermal fluid back into the reservoir, the pH should be controlled to support the corrosion inhibition as well as the iron content. If it comes to the nature releasing of the geothermal fluid, it could represent a risk for the surrounding flora and fauna. Furthermore, to protect borehole casing of the scaling and corrosion, inhibitors should be injected during exploitation phase.

Even though geothermal energy can be characterized as clean and sustainable energy source, the exploitation of geothermal fields can be associated with several environmental impacts. Namely, one of the most significant advantages of geothermal is its low carbon footprint. According to the International Energy Agency (IEA), geothermal energy produces less than 5% of the carbon dioxide that coal-fired power plants do per unit of electricity generated. However, the process of creating an artificial geothermal reservoir is associated

with various environmental challenges. The drilling required for EGS can lead to land degradation and habitat loss. Additionally, the high-pressure injection of water into the ground can trigger seismic activity, leading to what is known as induced seismicity. Furthermore, the groundwater contamination is one of the environmental risks because the water (i.e., geothermal fluid) being circulated through an EGS system is often mixed with chemicals to improve the heat-absorbing properties. During the operational phase of a geothermal power plant a noise impact study is performed for the selection of low-noise emission equipment, such as the air condenser, but also for proper positioning of the equipment on the power plant platform. Therefore, recommendations for sound insulation (for instance, anti-noise wall around the plant) to respect the noise regulations can be provided [135]. Despite these environmental challenges, the environmental impact can be minimized by careful site selection, proper regulations, and monitoring.

As presented in Chapter 2, Section 2.3.2 three main types of geothermal power plants are: dry steam, flash steam, and binary power plants. The first two use geothermal water/steam as a working fluid, and binary power plants use low boiling point working fluid [136]. The binary power plants are at the moment the only power plant types utilised in EGS projects. The heat from geothermal fluid (which circulates in the primary loop) is transferred to the working fluid (circulating in the secondary loop) via heat exchanger. However, the working fluid must meet two main requirements: it needs to have a low boiling temperature and a low latent heat for evaporation to accommodate for a low enthalpy/temperature of the primary fluid used in binary systems. Organic fluids, such as isobutene, cyclohexane, R134a, R245fa, etc. are a preferable choices for working fluids [137].

Technology is another aspect of geothermal projects. In other words, this comprises all power plant components that are used to produce and transmit heat and/or electricity, to pump the geothermal fluid, to transfer heat from primary to secondary loop, etc. Aside from the thermodynamic analysis, a comprehensive process should include an economic analysis or, at least, an analysis of the size and the technical feasibility of the main components (heat exchangers, turbomachines, pumps, etc.) [138]. Based on the estimated or calculated size of the heat exchangers and the turbine, the cost of the equipment can be also calculated. Furthermore, based on the estimated production and characteristic of the component the energy losses can be calculated. Consequently, the costs of operation and maintaining the power plant can be calculated.

According to [139] the societal acceptance is conditioned by the deviation from regular condition in the area and utility of the affected parties from the geothermal project. As

geothermal technologies are site-specific (the geology is different all over Europe and knowledge of the local conditions is essential) and capital-intensive, the needs regarding exploration, resource development, construction and O&M are covered by the local workforce. Although deep geothermal exploitation (including EGS) seems to have a high potential for sustainable energy generation in the long-term, especially the short term, effects such as induced seismicity and failures in communication may create anxieties and opposition among the directly and indirectly affected people that could hinder the further development and proliferation of this technology [140], [141]. Additionally, the societal acceptance level of EGS project is in high correlation with the fear of induced seismic events even though they are often not felt at the surface. Therefore, to increase the acceptance level of local community, different measures can and could be applied. These measures include: a) awareness and acceptance campaigns, b) opening up communication, c) translating commitments into action, d) third party multi-stakeholder monitoring, e) installation of environmental guarantee fund, f) resettlement, g) provision of benefits, h) protection of prior and ancestral rights, i) protection of patrimony, and j) advocacy for appropriate public policies [140].

Development of a geothermal energy projects requires also legal actions and obtaining different types of permits. Nevertheless, there are several requirements besides the legal ones to be satisfied, such as obtaining mining permits, environmental studies, and administrative and financial requirements. Additionally, it is important to account for the distance to the existing power grid in case of electricity generation and location of heating demand with heating network in case of heat production. Furthermore, if the water-cooling condenser is used in the binary power plant the distance to the water source is also important factor.

Table 5.4. Influencing factors in decision-making process related to investment in EGS (source: [142])

		<b>Reservoir</b>			
<b>SUBSURFACE</b>	<i>Main properties</i>		<i>Rock properties</i>		
	<ul style="list-style-type: none"> <li>• Geothermal gradient</li> <li>• Reliable and available geological data</li> <li>• Heat production rate of the reservoir – heat capacity and temperature</li> <li>• Seismic hazard</li> <li>• Exploration risk</li> <li>• Presence of abandoned gas and oil fields</li> </ul>		<ul style="list-style-type: none"> <li>• Porosity, <b>permeability</b>, electrical resistivity, density, seismic velocity, and activity</li> <li>• Thermal conductivity and diffusivity, streaming potential, stress shear modulus, heat capacity, compressibility</li> <li>• The existence of faults and fractures</li> <li>• The existence of aquifers and aquitards</li> <li>• Reservoir lifetime</li> </ul>		
	<b>Geothermal fluid</b>				
	<i>Hydrochemistry</i>		<i>Brine – rock interactions</i>		
<ul style="list-style-type: none"> <li>• Salinity, temperature, corrosion</li> <li>• Silica, carbonate scales</li> <li>• Mineral precipitation</li> <li>• Dissolution</li> <li>• Radioactivity (NORM)</li> <li>• pH</li> </ul>		<ul style="list-style-type: none"> <li>• Swelling of clay</li> <li>• Dynamic viscosity and fluid density</li> <li>• Dropping the brine temperature</li> <li>• <b>Circulation of the fluid (flow rate)</b></li> <li>• Solid particles</li> </ul>			
<b>SURFACE</b>	<b>Environment</b>				
	<i>Land use (surface disturbances)</i>			<i>Human health</i>	
	<ul style="list-style-type: none"> <li>• <b>Road connections</b>, air, flora, fauna</li> <li>• <b>Landscape protection</b></li> <li>• Subsidence</li> <li>• <b>Visual impact</b></li> <li>• <b>Waste heat</b></li> <li>• Lowering of the groundwater table</li> <li>• Fluid withdrawal</li> <li>• <b>Chemical and thermal pollution</b> – solid and liquid waste disposal to soil and water</li> </ul>			<ul style="list-style-type: none"> <li>• <b>Water pollution, crops influence</b></li> <li>• <b>Water use and consumption</b></li> <li>• Potable water supplies, underground water</li> <li>• Biological and thermal effects</li> <li>• <b>Protection of natural features, atmospheric emissions</b></li> </ul>	
	<b>Working fluid</b>				
	<i>Necessities</i>			<i>Impacts</i>	
	<ul style="list-style-type: none"> <li>• <b>Proximity of water source</b> (cooling)</li> <li>• <b>Size of the power plant</b></li> <li>• <b>Technological variant</b> (type of the fluid)</li> <li>• <b>Low boiling temperature</b></li> <li>• <b>Cooling mechanism</b></li> <li>• <b>Availability of alternative salt, sewage, or geothermal water</b></li> <li>• Thermal properties – density, specific heat, thermal conductivity, viscosity</li> <li>• <b>Power for fluid circulation</b></li> <li>• Saturation temperature/pressure</li> <li>• <b>Latent heat of evaporation</b></li> <li>• <b>Possibility for superheating</b></li> <li>• <b>Inlet and outlet turbine pressure</b></li> </ul>			<ul style="list-style-type: none"> <li>• <b>Impact on overall efficiency</b></li> <li>• <b>Boiling point and condensing film coefficients</b></li> <li>• <b>Flammability</b></li> <li>• <b>Environmental effects</b></li> <li>• <b>Toxicity</b></li> <li>• <b>Corrosion hazard</b></li> <li>• <b>Pollution</b></li> <li>• <b>Water losses</b></li> </ul>	
<b>Technology</b>					
<i>Economics</i>		<i>Efficiencies</i>	<i>Components</i>	<i>Reliability and durability</i>	
<ul style="list-style-type: none"> <li>• <b>Costs (capital and labour)</b></li> <li>• <b>Power plant size and type</b></li> <li>• <b>Connection to existing infrastructure</b></li> </ul>		<ul style="list-style-type: none"> <li>• <b>Heat loss from equipment</b></li> <li>• <b>Turbine, generator, heat exchanger, pumps efficiencies</b></li> <li>• <b>Fluid properties, resource type and temperature</b></li> </ul>	<ul style="list-style-type: none"> <li>• <b>Heat exchanger</b></li> <li>• <b>Turbine</b></li> <li>• <b>Condenser</b></li> <li>• <b>Grid access</b></li> </ul>	<ul style="list-style-type: none"> <li>• <b>Clogging</b></li> <li>• <b>Corrosion</b></li> <li>• <b>Equipment Reliability</b></li> </ul>	

Table 5.5. Influencing factors in decision-making process related to investment in EGS (source: [142]) (continued)

SURFACE	Social impact	
	Non-hazardous	Hazardous
	<ul style="list-style-type: none"> <li>• Cultural standards</li> <li>• Education</li> <li>• Employment</li> <li>• The questionable success of the project</li> <li>• Possible usage (agricultural, tourism, waste communal water, etc.)</li> </ul>	<ul style="list-style-type: none"> <li>• Distance to the nearest settlement (community)</li> <li>• Fear</li> <li>• Radioactive impact</li> <li>• Social acceptability</li> <li>• Induced seismicity</li> <li>• Noise during construction and operation</li> </ul>
Legal framework		
<ul style="list-style-type: none"> <li>• Fees, licences</li> <li>• Mining, technological, economic, administrative, financial, environmental policy</li> <li>• Ownership and protection state</li> <li>• Paperwork duration</li> <li>• Permits duration – exploration and exploitation licenses</li> <li>• Political support</li> <li>• Distance from the electrical grid</li> <li>• Distance from district heating system</li> <li>• Distance from cooling water</li> </ul>		

### 5.2.2. Criteria selecting method – the Delphi method

Based on the extensive review of all potentially influencing factors that could affect potential EGS project development (from previous Section 5.2.1), the selection process of the main factors, i.e. criteria can be done. Namely, as explained in Chapter 4, Section 4.3. the first step in MCDM process is selection of main influencing criteria, since not all the factors summarized in Table 5.4 and Table 5.5 have the same impact significance on the overall investment in EGS project. Therefore, as the criteria selection method the Delphi method was used. The reason for using the Delphi method is its concept based on the ‘consortium’ of experts that based on their specific knowledge and expertise background come to a consensus on the set of the main criteria. Therefore, this group of experts consisted of experts with geological background but also experts with engineering background (covering the non-geological expertise spectrum). Hence, the equilibrium between ‘subsurface’ and ‘surface’ phenomena and factors could be reached.

The Delphi method consisted of five main steps (Figure 5.2):

- 1) Identification and selection of the experts;
- 2) Conduction of the first round of questionnaire survey;
- 3) Conduction of the second round of the questionnaire survey;
- 4) Conduction of the third round of the questionnaire survey; and
- 5) Integrating the experts’ opinions and reaching of the consensus.

Steps 3) and 4) are normally repeated until a consensus is reached on a particular topic. The decision-making group generally should not be too large, i.e., a minimum of five to a maximum of about 50 is golden rule. It is suggested that the Delphi method summarize expert

opinions on a range from 10-30 [143]. Therefore, in this thesis 12 experts participated in the Delphi method. The conducted Delphi method ended after three rounds of questionnaire surveys. The consensus was reached and the defined set of criteria consists of twenty-eight influencing criteria and thirty-four sub-criteria which are used to evaluate the main criteria in more details [144], [145]. The twenty-eight criteria are summarized in Table 5.6.

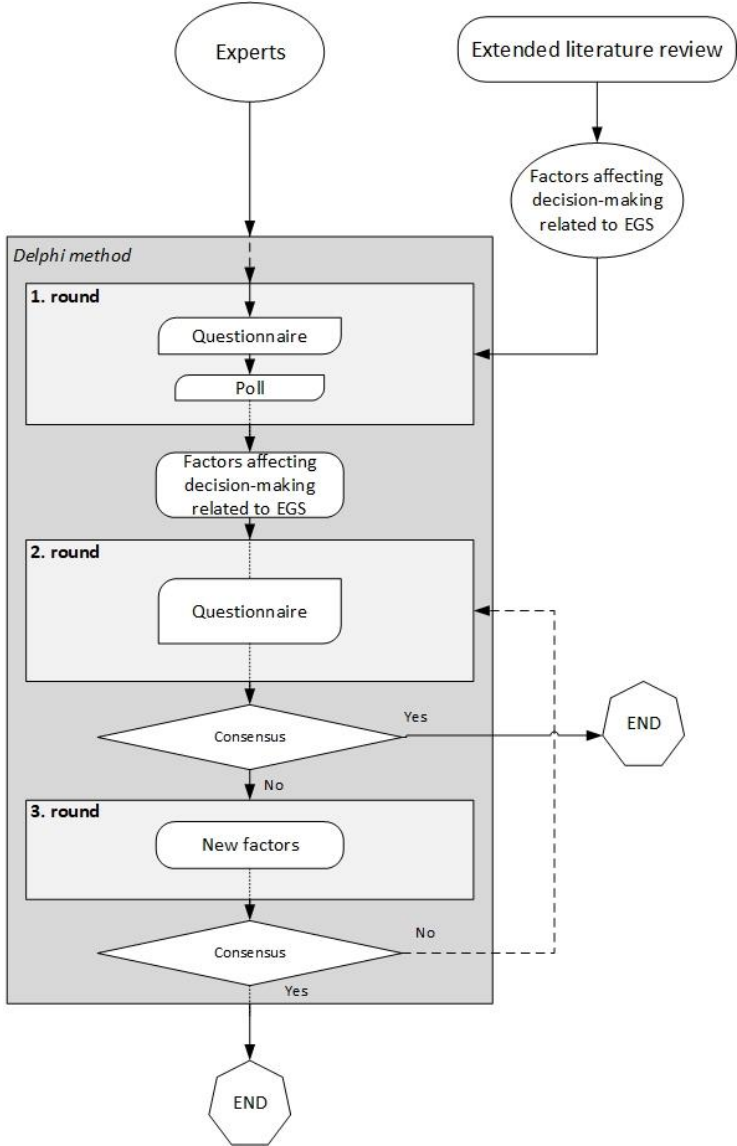

Figure 5.2. The Delphi method used in this thesis for criteria selection process

Table 5.6. Summarized twenty-eight criteria (influencing factors) (author's own work published in: [145])

<b>Criteria</b>			
Permeability	Capacity factor	LCOE/LCOH	Social acceptability
Porosity	Deployment duration	NPV (EAA)	Land use
Reservoir type	Proximity to the grid	Capital costs	Noise
Reservoir volume	Global efficiency	O&M costs	Avoided CO <sub>2</sub> emissions
Reservoir temperature	Wellhead temperature	Discounted payback period	Protected areas
Reservoir depth	Flow rate	Support schemes	Potential seismicity
Fluid heat capacity	Injection temperature	Job creation	Conflict with other subsurface uses

### 5.3. METHOD FOR STANDARDIZED EVALUATION OF DEFINED INFLUENCING CRITERIA

Once the main influencing criteria have been identified, the method for standardized evaluation of those criteria was developed. Namely, some of the identified criteria are quantitatively, and some qualitatively defined. Additionally, each criterion is expressed in different units and in different ranges of values. The EGS projects, as mentioned before, are also very site specific. Thus, the values of each criterion can significantly differ from site to site.

The method provides thresholds for each of twenty-eight criteria and thirty-four sub-criteria based on which a clear, objective, comprehensive, and understandable methodology for EGS criteria evaluation can be done [145].

As explained in Section 5.1.2. when considering assessment of geothermal energy utilization projects many different aspects should be considered. Namely, to assess feasibility of geothermal energy utilization at a candidate site, the extraction of geothermal heat, its conversion into heat or electric energy and transport to consumers should be considered. Moreover, this should also include economic aspects of the proposed application, covering costs of sub-surface activities, such as exploration, drilling and stimulation if needed, surface plant installation, maintenance and selling prices to potential end-users, etc. Additionally, societal and environmental impacts should be considered. One of the methods to include all relevant influencing factors is to establish the set of criteria. The defined set of criteria is then used as basis for integrated MCDM methodology presented in following Section 5.4.

In this method the performance,  $x_{ij}$ , of alternative  $i$  on criterion  $j$  is arbitrarily associated by numerical value ranging from 1 to 5,  $x_{ij} \in \{1,2,3,4,5\}$ , where higher value means better performance. Uniform distribution of the values is applied. Ranges are defined for each



criterion separately, based on the data from the literature as much as on knowledge of the experts involved in the criteria selection stage. The indices of performance values  $x_{ij}$  of all criteria are listed in Table 5.7.

The development of proposed method is summarized in a flow chart depicted in Figure 5.3. The set of criteria established in [144] represented a satisfying starting point for the development of a comprehensive framework to evaluate geothermal energy utilization projects on a global scale and in more detailed context. Additionally, literature review and real case studies survey enabled criteria selection. The included criteria are related to geological setting, technology, economy/finance, environment, and society. All criteria can therefore be grouped in one of the five categories as shown in Figure 5.4. Furthermore, to achieve higher level of detail, additional sub-criteria was defined for some criteria which is used for better description and consequently assessment of those criteria. Thresholds are defined for each sub-criterion and criterion based on the extensive literature review, authors expert knowledge, and real project case studies data. The defined set of criteria and corresponding thresholds are applied in the case study MCDM analysis presented in Section 5.3.2 where Weighted Decision Matrix (WDM) method is used to obtain overall project's (alternative) grade.

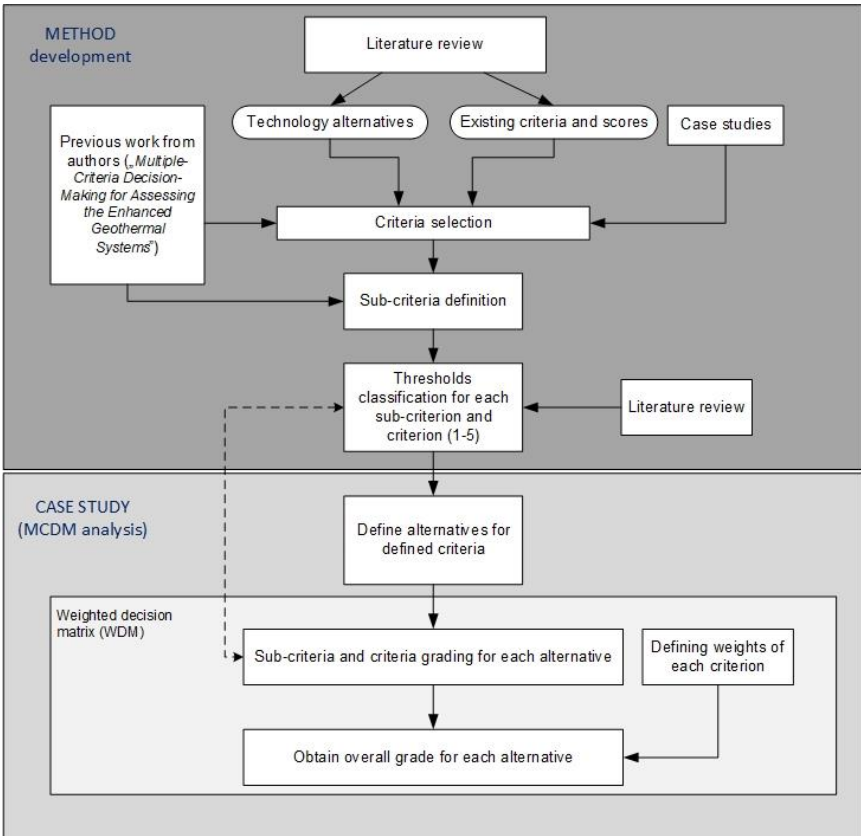

Figure 5.3. Scheme of the method developed in this Section 5.3. and the case study for verification

Geological setting	Technology	Economy/Finance	Society	Environment
Permeability Porosity Reservoir type Reservoir volume Reservoir temperature Reservoir depth Fluid heat capacity	Capacity factor Deployment duration Proximity to the grid Global efficiency Wellhead temperature Flow rate Injection temperature	LCOE/LCOH NPV (EAA) Capital costs O&M costs Discounted payback period Support schemes	Job creation Social acceptability	Land use Noise Avoided CO <sub>2</sub> emissions Protected areas Potential seismicity Conflict with other subsurface uses

Figure 5.4. All influencing criteria grouped in five main categories

Table 5.7. Performance value indices for all criteria

Parameter	Performance value
Permeability	$x_{i,1}$
Porosity	$x_{i,2}$
Reservoir type	$x_{i,3}$
Reservoir volume	$x_{i,4}$
Reservoir temperature	$x_{i,5}$
Reservoir depth	$x_{i,6}$
Fluid specific heat capacity	$x_{i,7}$
Capacity factor	$x_{i,8}$
Deployment duration	$x_{i,9}$
Proximity to the grid	$x_{i,10}$
Global efficiency	$x_{i,11}$
Wellhead temperature	$x_{i,12}$
Flow rate	$x_{i,13}$
Injection temperature	$x_{i,14}$
LCOE/LCOH	$x_{i,15}$
NPV (EAA)	$x_{i,16}$
Capital cost	$x_{i,17}$
O&M cost	$x_{i,18}$
Discounted payback period	$x_{i,19}$
Support schemes	$x_{i,20}$
Job creation	$x_{i,21}$
Social acceptability	$x_{i,22}$
Land use	$x_{i,23}$
Noise	$x_{i,24}$
Avoided CO <sub>2</sub> emissions	$x_{i,25}$
Protected area	$x_{i,26}$
Potential seismicity	$x_{i,27}$
Conflict with other subsurface uses	$x_{i,28}$

### 5.3.1. Grading thresholds for defined influencing criteria

Following from Sections 5.3.1.1. to Section 5.3.1.28 . are used to describe each criterion used in the developed method for standardized evaluation of criteria and to present the thresholds for both criteria and corresponding sub-criteria. First the criteria under geological setting criteria group are explained, then the technology criteria, following by the economy/finance criteria group, society group, and in the end the criteria from environmental group. The method was described and published comprehensively in [145].

### 5.3.1.1. Permeability

Beside the porosity, the permeability is the most significant physical property of the reservoir. However, when determining the effective reservoir, permeability is the more important factor because a reservoir rock can be porous without being permeable. The permeability of reservoirs with insufficient connectivity or aperture of its natural fracture network may be enhanced by hydraulic, chemical, or thermal stimulation. These commonly used stimulation techniques increase the productivity of the reservoir by either opening and connecting pre-existing, or by creating new fractures and hence an artificial underground heat exchanger. The ranges for this criterion are determined based on the systematic review of past and present deep geothermal systems, presented petrophysical properties of the reservoir [146], empirical data, and the study conducted in [147]. The dual permeability and dual porosity models are used for the interpretation of the fluid flow for stimulated and fractured petrothermal reservoirs. It is also assumed that the total porous system can be divided into two separate but interacting systems regarding the permeability and porosity [148]. This model assumes that the permeability within the fracture is larger than the matrix permeability since the matrix behaves as the local source to the fracture system and in that extent contributes to the fluid flow. The thresholds for evaluation of both permeability for low performance reservoirs and simulated and fractured systems (fracture system and matrix system permeability) are shown in Table 5.9.

. Namely, for low performance reservoirs, the total performance value  $x_{i,1}$  for permeability,  $\mu$ , is assessed according to the thresholds show in the first two rows of Table 5.9.

The total performance value  $x_{i,1}$  for permeability of the stimulated and fractured petrothermal reservoirs is evaluated by evaluating two sub-criteria of the dual permeability model: the fracture system permeability,  $\mu_f$ , and matrix system permeability,  $\mu_m$ . In this case the total performance value  $x_{i,1}$  for total permeability,  $\mu_{sum}$ , is calculated as the sum of performances of the two aforementioned sub-factors, which is calculated as the product of weight  $w_{i,j,z}$  of each sub-factor and its performance value  $x_{i,j,z}$ , shown in Table 5.8.

and according to Equation (5.1). The permeabilities  $\mu$ ,  $\mu_f$ , and  $\mu_m$  are measured in ( $m^2$ ) and the  $x_{i,1}$ , of alternative  $i$  for permeability criterion is evaluated with a numerical value from 1 to 5.

$$x_{i,1} = w_{i,1,1} \cdot x_{i,1,1} + w_{i,1,2} \cdot x_{i,1,2} \quad (5.1)$$

Table 5.8. Weight  $w_{i,j,z}$  of each sub-criterion for the permeability of stimulated and fractured petrothermal reservoirs

Sub-factor	Weight $w_{i,j,z}$
Fracture system permeability of stimulated and fractured petrothermal reservoirs	2
Matrix system permeability of stimulated and fractured petrothermal reservoirs	1

Table 5.9. Performance values  $x_{i,1}$  for permeability criterion

<b>Permeability of low performance reservoirs [m<sup>2</sup>]</b>	$\mu \leq 10^{-19}$	$10^{-19} < \mu \leq 10^{-18}$	$10^{-18} < \mu \leq 10^{-17}$	$10^{-17} < \mu \leq 10^{-16}$	$\mu > 10^{-16}$
$x_{i,1}$	1	2	3	4	5
<b>Fracture system permeability of stimulated and fractured petrothermal reservoirs [m<sup>2</sup>]</b>	$\mu_f \leq 10^{-17}$	$10^{-17} < \mu_f \leq 10^{-16}$	$10^{-16} < \mu_f \leq 10^{-15}$	$10^{-15} < \mu_f \leq 10^{-14}$	$\mu_f > 10^{-14}$
$x_{i,1,1}$	1	2	3	4	5
<b>Matrix system permeability of stimulated and fractured petrothermal reservoirs [m<sup>2</sup>]</b>	$\mu_m \leq 10^{-18}$	$10^{-18} < \mu_m \leq 10^{-17}$	$10^{-17} < \mu_m \leq 10^{-16}$	$10^{-16} < \mu_m \leq 10^{-15}$	$\mu_m > 10^{-15}$
$x_{i,1,2}$	1	2	3	4	5
<b>Permeability of stimulated and fractured petrothermal reservoirs [-]</b>	$3 < \mu_{sum} \leq 5,4$	$5,4 < \mu_{sum} \leq 7,8$	$7,8 < \mu_{sum} \leq 10,2$	$10,2 < \mu_{sum} \leq 12,6$	$12,6 < \mu_{sum} \leq 15$
$x_{i,1}$	1	2	3	4	5

### 5.3.1.2. Porosity

Porosity is the capacity of the reservoir rocks to contain or store fluids. Therefore, the porosity,  $\phi$ , is measured by the percentage of empty space that exists within a particular porous media. The thresholds for porosity criterion are defined to be best suitable for assessment of low-performance reservoirs, petrothermal systems where stimulation is usually needed (i.e., stimulated reservoirs), and fractured petrothermal reservoirs. For fractured petrothermal reservoirs and stimulated reservoirs the porosity is, like permeability, interpreted with dual-porosity model. The main assumption in the dual-porosity model is that the fracture system is the main driver of the fluid flow in the reservoirs and the matrix system acts as reservoir storage and a source to the fracture system, hence the porosity of the fracture system is greater than the matrix system [148]. The thresholds for performance value  $x_{i,2}$  of alternative  $i$  for the porosity criterion are shown in Table 5.11. Namely, for low performance

reservoirs, the total performance value,  $x_{i,2}$ , for porosity,  $\phi$ , is assessed according to the thresholds shown in the first two rows of Table 5.11. The total performance value  $x_{i,2}$  for porosity of fractured and stimulated petrothermal reservoirs is evaluated by assessing two sub-criteria of the dual porosity model: the fracture system porosity,  $\phi_f$ , and matrix system porosity,  $\phi_m$ . In this case the total performance value  $x_{i,2}$  for total porosity,  $\phi_{sum}$ , is calculated according to the Equation (5.2) as the sum of performances of the aforementioned sub-factors, which is calculated as the product of weight  $w_{i,2,z}$  of each sub-factor (Table 5.10) and its performance value  $x_{i,j,z}$ . The porosities  $\phi$ ,  $\phi_f$ , and  $\phi_m$  are measured in p.u.

$$x_{i,2} = w_{i,2,1} \cdot x_{i,2,1} + w_{i,2,2} \cdot x_{i,2,2} \quad (5.2)$$

Table 5.10. Weight  $w_{i,j,z}$  for each sub-criterion for the porosity of stimulated and fractured petrothermal reservoir

Sub-factor	Weight $w_{i,2,z}$
Fracture system porosity of stimulated and fractured petrothermal reservoirs	2
Matrix system porosity of stimulated and fractured petrothermal reservoirs	1

Table 5.11. Performance values  $x_{i,2}$  for porosity criterion

<b>Porosity of low performance reservoirs</b> [p.u.]	$\phi < 0.01$	$0.01 \leq \phi < 0.04$	$0.04 \leq \phi < 0.08$	$0.08 \leq \phi < 0.12$	$\phi \geq 0.12$
$x_{i,2}$	1	2	3	4	5
<b>Fracture system porosity of stimulated and fractured petrothermal reservoirs</b> [p.u.]	$\phi_f < 0.05$	$0.05 \leq \phi_f < 0.10$	$0.10 \leq \phi_f < 0.15$	$0.15 \leq \phi_f < 0.20$	$\phi_f \geq 0.20$
$x_{i,2,1}$	1	2	3	4	5
<b>Matrix system porosity of stimulated and fractured petrothermal reservoirs</b> [p.u.]	$\phi_m < 0.03$	$0.03 \leq \phi_m < 0.07$	$0.07 \leq \phi_m < 0.11$	$0.11 \leq \phi_m < 0.15$	$\phi_m \geq 0.15$
$x_{i,2,2}$	1	2	3	4	5
<b>Porosity of stimulated and fractured petrothermal reservoirs</b> [-]	$3 < \phi_{sum} \leq 5,4$	$5,4 < \phi_{sum} \leq 7,8$	$7,8 < \phi_{sum} \leq 10,2$	$10,2 < \phi_{sum} \leq 12,6$	$12,6 < \phi_{sum} \leq 15$
$x_{i,2}$	1	2	3	4	5

### 5.3.1.3. Reservoir type

The reservoirs are classified based on the overall reservoir productivity and sustainable utilization. Namely, to cover the major reservoir parameters the geothermal reservoirs are divided into three different groups. The first group are low-performance reservoirs where the geothermal potential is proven but the commercial production is disabled due to unfavourable geological setting (e.g., low permeability and porosity, impermeable layers, lower reservoir volume, etc.). According to [149], such reservoirs are mainly conduction-dominated with low to medium enthalpy due to a lack of convective fluid flow. Additionally, such reservoirs are mainly located in low-permeable rock such as crystalline rock, carbonates, and tight sandstone. For utilization of such reservoirs the stimulation techniques are required to enhance the naturally occurring geological setting. The second group represents stimulated reservoirs where the productivity of the reservoir was increased using one of the stimulation techniques (see Chapter 2, Section 2.4.2.2). The third group represents fractured petrothermal reservoirs that are characterized with favourable permeability and porosity, and no stimulation techniques are required for exploitation of such reservoirs. The fractured reservoirs are characterized by the fractured, fissured, faulted zones mainly in Paleozoic-Mesozoic carbonates and crystalline reservoirs located in active tectonic settings with the presence of high secondary porosity [150], and also in the active tectonic and volcanic zones where the reservoir temperature and the tectonic activity keep the fractures open for geothermal fluid flow and thus increasing the permeability [151]. The thresholds for the performance value  $x_{i,3}$  of alternative  $i$  on the reservoir type criterion for three main groups of reservoirs are shown in Table 5.12.

Table 5.12. Performance values  $x_{i,3}$  for reservoir type criterion

Reservoir type	<i>Low performance reservoirs</i>	<i>Stimulated reservoirs</i>	<i>Fractured petrothermal reservoirs</i>
$x_{i,3}$	1	3	5

### 5.3.1.4. Reservoir volume

Sustainable heat mining requires larger reservoir volumes, otherwise the resource could be exploited too quickly. In the early stages of exploration, the reservoir volume size is often represented based on assessments of reservoir thickness and area, but it should be taken with precaution since it represents an oversimplification of the actual reservoir geometry [145]. A minimum volume of 0.1 km<sup>3</sup> and above 1 km<sup>3</sup> for the highest grade was chosen based on an analysis of power generation from EGS conducted in [152]. The thresholds for the

performance value  $x_{i,4}$  of alternative  $i$  on the reservoir volume criterion denoted as  $V$  and measured in ( $\text{km}^3$ ) are defined as shown in Table 5.13.

Table 5.13. Performance values  $x_{i,4}$  for reservoir volume criterion

Reservoir volume [ $\text{km}^3$ ]	$V \leq 0.1$	$0.1 < V \leq 0.4$	$0.4 < V \leq 0.7$	$0.7 < V \leq 1$	$V > 1$
$x_{i,4}$	1	2	3	4	5

### 5.3.1.5. Reservoir temperature

The reservoir temperature is one of the most common criteria for classification of the geothermal resource based on the fact that it is relatively easy measurable and understandable. Additionally, this parameter is available for the decision-makers very early in the exploration phase. Depending on the temperature range, various applications of geothermal energy can be specified. This methodology focuses on low enthalpy resources, and according to the [153] and [154] many authors have classified low enthalpy geothermal resources differently and some of them have been shown in Table 5.14. Additionally, as mentioned previously, the Lindal diagram is usually used to show the ranges of reservoir temperature and the utilization of geothermal energy for those temperatures. Based on the classification of the low enthalpy geothermal systems in Table 5.14 and on fact that the developed method is mainly focused for the resources up to 160 °C the thresholds for the performance value  $x_{i,5}$  of alternative  $i$  for the reservoir temperature criterion  $T_{res}$  measured in (°C) are given in Table 5.15. The thresholds also reflect the modified Lindal diagram shown in Figure 5.5.

Table 5.14. Classification of low enthalpy geothermal resources

Reference	[155]	[153]	[156]	[157]	[158]	[159]
Temperature [°C]	< 90	< 125	< 100	≤ 150	≤ 190	< 190

Table 5.15. Performance values  $x_{i,5}$  for reservoir temperature criterion

Reservoir temperature [°C]					
<b>Direct utilization</b>					
<i>District heating</i> [160]	$T_{res} < 60$	$60 \leq T_{res} < 70$	$70 \leq T_{res} < 80$	$80 \leq T_{res} < 90$	$T_{res} \geq 90$
<i>Greenhouse heating</i>	$T_{res} < 40$	$40 \leq T_{res} < 60$	$60 \leq T_{res} < 80$	$80 \leq T_{res} < 100$	$T_{res} \geq 100$
<i>Agricultural drying</i> [161], [162]	$T_{res} < 60$	$60 \leq T_{res} < 75$	$75 \leq T_{res} < 90$	$90 \leq T_{res} < 105$	$T_{res} \geq 105$
<i>Balneology</i>	$T_{res} < 30$	$30 \leq T_{res} < 40$	$40 \leq T_{res} < 50$	$50 \leq T_{res} < 60$	$T_{res} \geq 60$
<i>Industrial uses</i> [163]	$T_{res} < 60$	$60 \leq T_{res} < 70$	$70 \leq T_{res} < 80$	$80 \leq T_{res} < 90$	$T_{res} \geq 90$
<b>Electricity generation</b> [144], [164], [165]	$T_{res} < 60$	$60 \leq T_{res} < 80$	$80 \leq T_{res} < 100$	$100 \leq T_{res} < 120$	$T_{res} \geq 120$
<b>CHP</b> [48], [166], [167]	$T_{res} < 70$	$70 \leq T_{res} < 90$	$90 \leq T_{res} < 110$	$110 \leq T_{res} < 130$	$T_{res} \geq 130$
$x_{i,5}$	1	2	3	4	5

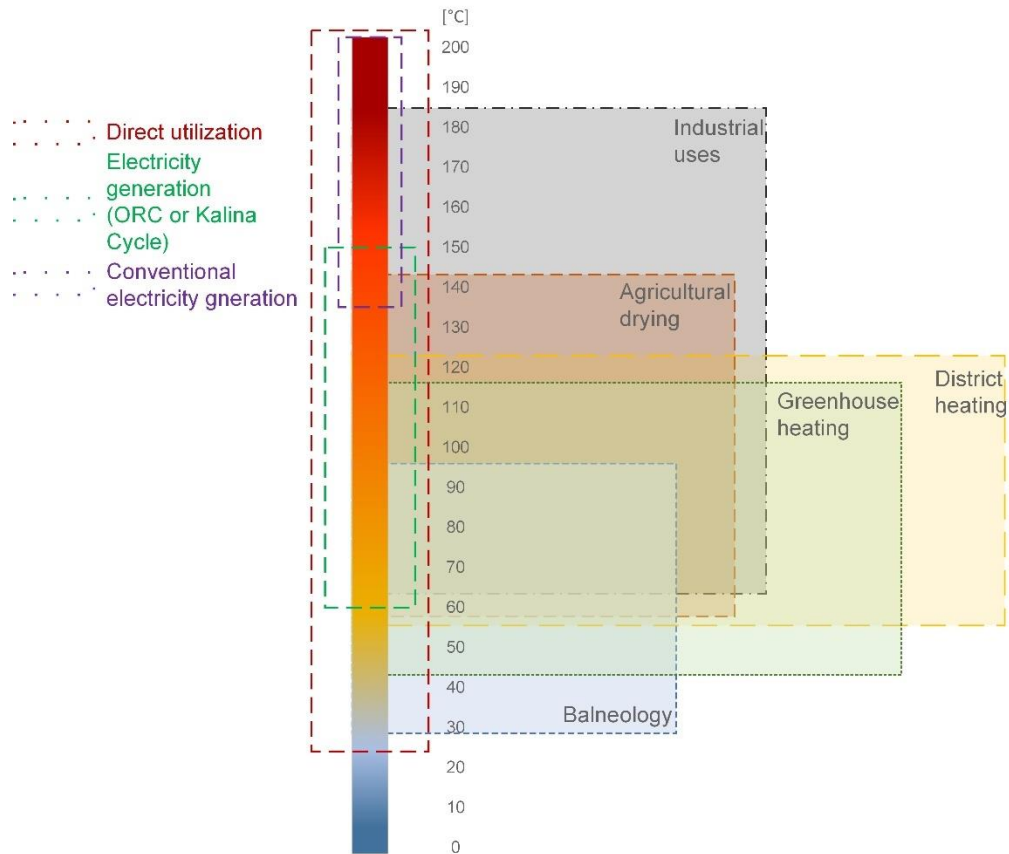

Figure 5.5. Modified Lindal diagram according to state of the art today (author's own work published in: [145])

### 5.3.1.6. Reservoir depth

The EGS technology has enabled deeper and previously inaccessible reservoirs and geological formations to become reachable and usable. Hence, it is increasing the potential of accessible geothermal energy and exploiting part of the geothermal potential that could not be exploited with conventional techniques. The reservoir depth represents a great challenge when considering deep geothermal energy utilization. The drilling time increases with the depth of drilled wells, which consequently increases the cost of a well and simultaneously the likelihood of equipment failures also increases, i.e. the risks related to the drilling are rising [168], [169]. Furthermore, while drilling to deeper layers, many different formations and rock types can be intersected which represents increased risk of geologically caused drilling problems. According to different studies [28], [72], [81], [170]–[173] the measured well depth is to be a reliable indicator of drilling costs. Therefore, the measured depth,  $MD$ , is considered as the first sub-factor when evaluating the reservoir depth criterion. The performance value  $x_{i,6,1}$  of this sub-factor is assessed with values from 1 to 5 as shown in Table 5.17.

Furthermore, to better reflect geological, physical, logistical, and economical aspects of drilling difficulties related to reaching the desired reservoir depth, the well direction and



bottom-hole diameter [174] are considered as sub-factors in this methodology. The classification of the well directions is made according to the information elaborated in Chapter 2, Section 2.4.2.2. Vertical drilling is generally considered less expensive because it represents the shortest drilling length. However, because of any geological hazards or even land restrictions at the surface, it is often difficult to access the targeted reservoir by drilling a vertical well. Additionally, according to [71] vertical wells cannot optimally exploit the geothermal resource because of the near-vertical orientation of fractures and faults, that are often present in EGS environments. Directional drilling has become more popular [175], however this is a more complex technology and there are many ways to drill a deviated hole which introduces additional risks. In this method vertical wells are considered those where well angle does not exceed  $10^\circ$  in respect to the vertical axis, directional where well angle reaches maximum angle of  $60^\circ$  in respect to the vertical axis, and horizontal where bottom-hole well angle is between  $60^\circ$  and  $90^\circ$  in respect to the vertical axis [145]. This is the second sub-factor, which performance value  $x_{i,6,2}$  is assessed with values from 1 to 5 as shown in Table 5.17.

The location of the production zone and flow rate requirements dictate the diameter at the bottom of the hole according to [169]. The rest of the well can be designed based on nominal pipe size and necessity for casing zones once this bottom diameter has been determined. Larger bottom-hole diameters require larger casing strings in sections above, and the number of casing intervals depends both on the geological complexity and on the depth of the well [174]. Therefore, the bottom-hole diameter directly influences the cost and together with the depth the complexity of drilling process [176], [177] and is considered also as third sub-factor. The performance value  $x_{i,6,3}$  of bottom hole diameter, *bhd*, sub-factor is assessed with values from 1 to 5 as shown in Table 5.17.

The contribution of each above-mentioned sub-factors to the overall performance  $x_{i,6}$  on alternative  $i$  for reservoir depth criterion is slightly different. Namely, the well depth (average, in case of series of wells within a wellfield) is accounted as the most important, following by the well direction and bottom-hole diameter as the equally influencing parameters (Table 5.16). As mentioned each sub-factor is evaluated based to the thresholds in Table 5.17, which are defined and modified from [178]. The total performance value  $x_{i,6}$  of alternative  $i$  for reservoir depth ( $rd_{sum}$ ) criterion is obtained as the sum of performances of sub-factors which are calculated as the product of weight  $w_{i,6,z}$  of each sub-factor and its performance value  $x_{i,6,z}$  as shown in Equation (5.3).

$$x_{i,6} = w_{i,6,1} \cdot x_{i,6,1} + w_{i,6,2} \cdot x_{i,6,2} + w_{i,6,3} \cdot x_{i,6,3} \quad (5.3)$$

Table 5.16. Weight  $w_{i,j,z}$  of each sub-factor in the reservoir depth criterion

Sub-factor	Weight $w_{i,6,z}$
Well depth	2
Well direction	1
Bottom-hole diameter	1

Table 5.17. Performance values  $x_{i,6}$  for reservoir depth criterion

<b>Well depth</b> [m]	$MD \geq 5,500$	$4,500 \leq MD < 5,500$	$3,500 \leq MD < 4,500$	$2,500 \leq MD < 3,500$	$MD < 2,500$
$x_{i,6,1}$	1	2	3	4	5
<b>Well direction</b> [-]	<i>horizontal</i>	-	<i>directional</i>	-	<i>vertical</i>
$x_{i,6,2}$	1	2	3	4	5
<b>Bottom-hole diameter<sup>1</sup></b> [cm]	$bhd > 31.12$	$24.45 < bhd \leq 31.12$	$21.59 < bhd \leq 24.45$	$17.78 < bhd \leq 21.59$	$bhd \leq 17.78$
$x_{i,6,3}$	1	2	3	4	5
<b>Reservoir depth</b> [-]	$4 \leq rd_{sum} < 7$	$7 \leq rd_{sum} < 10$	$10 \leq rd_{sum} < 13$	$13 \leq rd_{sum} < 16$	$16 \leq rd_{sum} \leq 20$
$x_{i,6}$	1	2	3	4	5

### 5.3.1.7. Fluid heat capacity

The fluid heat capacity criterion represents the specific heat capacity of produced geothermal fluid which varies with reservoir temperature and pressure, and the composition of the fluid itself. According to [179], the increase in brine salinity leads to the decrease in fluids enthalpy which is caused by the consequential decrease in specific heat capacity. Contrarily, the pressure drop along the wellbore is increased due to greater fluid density, which together results in higher operational costs and lower geothermal energy production. Due to the complex determination of specific heat capacity of geothermal fluid, in this method a simplified approach for defining this criterion using the NaCl equivalent concentration is proposed. Namely, a study conducted in [179], where the performance of the geothermal system with geothermal fluid is compared to system performance where it is assumed that the fluid is solely NaCl solution of equivalent salinity, concluded that the fluids with lower total dissolved solids (0-30 g/kg) and moderate-depth geothermal reservoirs with high sodium and/or potassium concentration ( $\text{NaCl} > 50\%$  TDS,  $\text{NaCl} + \text{KCl} > 60\%$  TDS) can be approximated with the pure NaCl solution for further calculations. The fluid temperature,  $T_f$ , and fluid concentration,  $conc$ , have therefore been taken into account as sub-factors and

arranged in thresholds with corresponding performance grade according to [180] (Table 5.18). Additionally, the fluid concentration performance grade,  $x_{i,7,1}$ , is multiplied by 2 to emphasize the influence on the specific heat capacity, while fluid temperature performance grade,  $x_{i,7,2}$ , is multiplied by 1, as shown in Equation (5.4). Therefore, the total performance value  $x_{i,7}$  of alternative  $i$  for fluid heat capacity criterion,  $c$ , is calculated as the sum of performances of sub-factors which are calculated as the product of weight  $w_{i,7,z}$  of each sub-factor (Table 5.19.) and its performance value  $x_{i,7,z}$  as shown in Equation (5.4).

$$x_{i,7} = w_{i,7,1} \cdot x_{i,7,1} + w_{i,7,2} \cdot x_{i,7,2} \quad (5.4)$$

Table 5.18. Weight  $w_{i,7,z}$  of each sub-factor in the fluid heat capacity criterion

Sub-factor	Weight $w_{i,7,z}$
Fluid concentration	2
Fluid temperature	1

Table 5.19. Performance values  $x_{i,7}$  for fluid heat capacity criterion

Fluid concentration [NaCl g/kg]	$conc \geq 160$	$160 > conc \geq 120$	$120 > conc \geq 80$	$80 > conc \geq 40$	$conc < 40$
$x_{i,7,1}$	1	2	3	4	5
Fluid Temperature [°C]	$T_f \leq 60$	$60 < T_f \leq 100$	$100 < T_f \leq 140$	$140 < T_f \leq 180$	$T_f > 180$
$x_{i,7,2}$	1	2	3	4	5
Fluid heat capacity [-]	$3 \leq c < 5,4$	$5,4 \leq c < 7,8$	$7,8 \leq c < 10,2$	$10,2 \leq c < 12,6$	$12,6 \leq c \leq 15$
$x_{i,7}$	1	2	3	4	5

### 5.3.1.8. Capacity factor

The capacity factor is a ration of the actually produced energy in a given period and the hypothetical maximum possible production during the same period. Depending on the utilization category (i.e. application), the capacity factor varies from 0.189 to 0.610 for direct heat utilization alternatives based on the average data from 2015-2020 [181], and from 0.7 to 0.98 for electricity generation [4]. To define the thresholds for direct heat utilization options the capacity factors,  $cf$ , of five-years' time span for various categories in the period from 1995 to 2020 were used [44], [181]. Thresholds for capacity factor,  $cf$ , for electricity generation have been determined based on the available data for capacity factors for individual power plants across the world, and based on the national geothermal generation capacity factors [4], [182]–[184]. The capacity factor can change seasonally in case of CHP

plants, which highly depends on the configuration of the CHP plants, geographical location of the plant, and direct heat utilization which can be characterized with high seasonality (district heating) or low seasonality (industrial use). The thresholds for capacity factor,  $cf$ , for CHP power plants are based on the published data for several operational CHP plants across the world [166], [185], [186]. The thresholds for each end use application for evaluation of the performance value  $x_{i,8}$  of alternative  $i$  for capacity factor criteria are shown in Table 5.20.

Table 5.20. Performance values  $x_{i,8}$  for capacity factor criteria

<b>Capacity factor [p.u.]</b>					
<b>Direct utilization</b>					
<i>District heating</i>	$cf < 0.37$	$0.37 \leq cf < 0.403$	$0.403 \leq cf < 0.436$	$0.436 \leq cf < 0.47$	$cf \geq 0.47$
<i>Greenhouse heating</i>	$cf < 0.455$	$0.455 \leq cf < 0.463$	$0.463 \leq cf < 0.471$	$0.471 \leq cf < 0.478$	$cf \geq 0.478$
<i>Agricultural drying</i>	$cf < 0.4$	$0.4 \leq cf < 0.444$	$0.444 \leq cf < 0.488$	$0.488 \leq cf < 0.532$	$cf \geq 0.532$
<i>Tourism</i>	$cf < 0.31$	$0.31 \leq cf < 0.419$	$0.419 \leq cf < 0.529$	$0.529 \leq cf < 0.637$	$cf \geq 0.637$
<i>Industrial uses</i>	$cf < 0.54$	$0.54 \leq cf < 0.597$	$0.597 \leq cf < 0.654$	$0.654 \leq cf < 0.712$	$cf \geq 0.712$
<b>Electricity generation</b>	$cf < 0.65$	$0.65 \leq cf < 0.7$	$0.7 \leq cf < 0.75$	$0.75 \leq cf < 0.8$	$cf \geq 0.8$
<b>CHP</b>	$cf < 0.1$	$0.1 \leq cf < 0.2$	$0.2 \leq cf < 0.3$	$0.3 \leq cf < 0.4$	$cf \geq 0.4$
$x_{i,8}$	1	2	3	4	5

#### 5.3.1.9. Deployment duration

Deployment duration is defined as the preparation time for the facility to be ready to generate electricity or produce heat or both. For the already developed geothermal fields this period includes construction and installation of a power plant. However, for the yet undeveloped geothermal fields it additionally includes permitting, exploration, drilling, and field development phases. According to the literature [43], [187] the construction phase of geothermal plants usually takes two to four years. Additionally, heating facilities are simpler in design compared to electricity generating power plants. Therefore, it can be assumed that they require less construction time, around two years. This criterion was used in several studies [188]–[193] and is expressed in years. The thresholds for evaluation of the performance value  $x_{i,9}$  of alternative  $i$  for deployment duration criterion (Table 5.21) have been determined according to the literature and are separated in two groups depending on type of the geothermal project that is under evaluation. Therefore, this method distinguishes already developed, and undeveloped geothermal fields. The thresholds for deployment duration,  $t_{dep}$ , are the used accordingly and as presented in Table 5.21.

Table 5.21. Performance values  $x_{i,9}$  for deployment duration criterion

Deployment duration [years]					
Undeveloped projects	$t_{dep} > 11$	$9 < t_{dep} \leq 11$	$7 < t_{dep} \leq 9$	$5 < t_{dep} \leq 7$	$t_{dep} \leq 5$
Developed projects	$t_{dep} > 4$	$3 < t_{dep} \leq 4$	$2 < t_{dep} \leq 3$	$1 < t_{dep} \leq 2$	$t_{dep} \leq 1$
$x_{i,9}$	1	2	3	4	5

### 5.3.1.10. Proximity to the grid

The distance between the geothermal power plant and the nearest power grid connection point is also influencing factor [144]. The costs of interconnection to an existing transmission/distribution infrastructure may impose certain challenges even if the potential geothermal project is near to transmission line or distribution network in case of electricity production, or near heat end users and heating network connection point in case of heat production.

For geothermal power plants, the interconnection costs are upfront costs paid by the developer to connect power plant to the existing power grid. Starting point of the interconnection process is a query to the utility/transmission line operator/distribution network operator to access the lines. This process provides developers a path with available capacity and estimates the interconnection costs which include engineering costs (for developer engineering drawings which are to be submitted with the interconnection request to utility), feasibility and grid connection study costs (paid by developer to utility or third party to conduct feasibility and grid connection analysis), and interconnection costs (costs to connect to the grid including transmission systems upgrade or distribution network upgrade costs which depends on the feasibility and grid connection studies) [145]. Costs related to the interconnection activities (transmission lines, distribution network upgrades, substations etc.) can vary considerably from project to project and are also very country specific. Therefore, to grade this sub-factor, a linguistic evaluation is proposed as shown in Table 5.22. The overall performance value,  $x_{i,10}$ , for only electricity generation option for proximity to the grid,  $prox_{grid}$ , is obtained as the sum of the grades for two sub-factors: distance to the nearest transmission line,  $x_{i,10,1}$ , and interconnection costs,  $x_{i,10,2}$ . The thresholds for the performances  $x_{i,10,z}$  of alternative  $i$  for proximity to the grid criterion,  $prox_{grid}$ , for only electricity generation are shown in Table 5.22.

Table 5.22. Performance values  $x_{i,10}$  for proximity to the grid criterion for electricity generation option

Distance to the nearest transmission line [km]	$d > 8$	$6 < d \leq 8$	$4 < d \leq 6$	$2 < d \leq 4$	$d \leq 2$
	1	2	3	4	5
$x_{i,10,1}$	1	2	3	4	5
<b>Interconnection costs</b>	Utility concludes that interconnection is not feasible and therefore not possible	Significant transmission system or distribution network costs (greater than 0.5 M€/MW) plus feasibility and engineering costs	Significant transmission system or distribution network costs (up to 0.5 M€/MW) plus feasibility and engineering costs	Minor transmission system costs plus feasibility and engineering costs	No interconnection system costs, only feasibility costs plus engineering cost
$x_{i,10,2}$	1	2	3	4	5
<b>Proximity to the grid</b> [-]	$prox_{grid} \leq 2$	$2 < prox_{grid} \leq 4$	$4 < prox_{grid} \leq 6$	$6 < prox_{grid} \leq 8$	$8 < prox_{grid} \leq 10$
$x_{i,10}$	1	2	3	4	5

Considering heat production facility there are also different sub-factors that affect the overall performance of heating system and consequently the economics of such geothermal project. Generally, the source of a geothermal fluid used in the direct applications is located at some distance from the end users. Therefore, a transmission pipeline is necessary to enable the transport of the geothermal fluid. The length of the pipeline (first sub-factor),  $l_{pipe}$ , impacts the investment and operational costs of such system. In general, the bigger the length, the higher the costs. However, some additional factors should be considered. Optimization of pipe diameter (second sub-factor),  $d_p$ , is also important for the economic viability of the whole system [194]. Additionally, the pipe diameter has also large impact on operational costs. Larger pipe diameters result in higher unit costs. The use of pre-insulated pipes in geothermal direct heating applications minimizes the heat losses during the transmission which represents one of the main losses of revenues, and therefore pipeline insulation status is additional sub-factor. Moreover, pipelines are installed either aboveground or underground, so pipeline installation position is also considered as sub-factor. Although the aboveground installation eliminates the conflicts with other buried utilities, they are more subject to damage and vandalism. Underground installations are aesthetically more appealing and safer for damage. Despite many advantages, but due to higher investment costs of the concrete tunnel, most of the underground installation are generally directly buried into the soil. The thresholds for the performances  $x_{i,j,z}$  of alternative  $i$ , on each sub-factor related to proximity to the grid criterion for only direct heat utilization processes are shown in Table 5.23. The overall performance value  $x_{i,10}$  for direct utilization options for proximity to the grid,

$prox_{grid}$ , is obtained as the sum of the sub-grades for length,  $x_{i,10,1}$ , pipe diameter,  $x_{i,10,2}$ , insulation,  $x_{i,10,3}$ , and installation,  $x_{i,10,4}$ .

Table 5.23. Performance value  $x_{i,10}$  for proximity to the grid criterion for direct utilization options

<b>Length</b> [km]	$12 < l_{pipe}$	$9 < l_{pipe} \leq 12$	$6 < l_{pipe} \leq 9$	$3 < l_{pipe} \leq 6$	$l_{pipe} \leq 3$
$x_{i,10,1}$	1	2	3	4	5
<b>Pipe diameter</b> [-]	$d_p > DN800$	$DN400 < d_p \leq DN800$	$DN200 < d_p \leq DN400$	$DN100 < d_p \leq DN200$	$d_p \leq DN100$
$x_{i,10,2}$	1	2	3	4	5
<b>Insulation</b> [-]	<i>uninsulated</i>	-	<i>insulated</i>	-	<i>pre-insulated</i>
$x_{i,10,3}$	1	2	3	4	5
<b>Installation</b> [-]	<i>aboveground</i>	-	<i>underground concrete tunnel</i>	-	<i>underground directly buried</i>
$x_{i,10,4}$	1	2	3	4	5
<b>Proximity to the grid</b> [-]	$prox_{grid} < 8$	$8 \leq prox_{grid} < 13$	$13 \leq prox_{grid} < 18$	$18 \leq prox_{grid} < 23$	$prox_{grid} \geq 23$
$x_{i,10}$	1	2	3	4	5

The overall performance value  $x_{i,10}$  of alternative  $i$  for proximity to the grid criterion for CHP production is calculated as the average value of grade for proximity to the grid for electricity generation and grade for proximity to the grid for direct heat utilization (Table 5.24).

Table 5.24. Performance values  $x_{i,10}$  for proximity to the grid criterion for CHP option

<b>Proximity to the grid</b> [-]	$prox_{grid} \leq 1$	$1 < prox_{grid} \leq 2$	$2 < prox_{grid} \leq 3$	$3 < prox_{grid} \leq 4$	$4 < prox_{grid} \leq 5$
$x_{i,10}$	1	2	3	4	5

### 5.3.1.11. Global efficiency

The supply of heat and/or electricity is directly related to not only geological setting and wellbore conditions but also to the performance of the geothermal facility in terms of conversion of the energy. Therefore, a global efficiency criterion was established to evaluate the multi-stage heat (energy) loss within the energy conversion cycle. The total heat loss can be addressed with coefficients for different stages of the conversion cycle resulting in an overall evaluation for plant conversion [23]. The coefficients are: i) heat loss due to Non-Condensable Gases (NCG) (Equation (5.5)); ii) the parasitic heat loss including well pumps, cooling tower, and condenser (Equation (5.6)); and iii) parasitic loss during the working fluid transport (Equation (5.7)).

$$\eta_{NCG} = 1 - 0.0059 \cdot C \quad (5.5)$$

$$\eta_{TPL} = 1 - P_{TPL}/P_{gross} \quad (5.6)$$

$$\eta_{pipe} = 1 - 0.003 \cdot L_p \quad (5.7)$$

In Equation (5.5),  $C$  (%) represents the estimate of NCG weight, because the presence of NCG impact negatively the operation of the turbine. In Equation (5.6),  $P_{TPL}$  is total parasitic load (MW) and  $P_{gross}$  gross is thermal power (MW<sub>t</sub>). In Equation (5.7),  $L_p$  (km) is the pipe length.

Global efficiency of the power plant is then calculated according to the Equations (5.8) – (5.10). Equation (5.8) is used to calculate the global efficiency  $\eta_{G(E)}$  (p.u.) in case of electricity generation; Equation (5.9) is used to calculate the global efficiency  $\eta_{G(DH)}$  (p.u.) of direct heat usage of heating power; Equation 5.10 is used for CHP global efficiency  $\eta_{G(CHP)}$  (p.u.) calculation:

$$\eta_{G(E)} = \eta_{max} \cdot \eta_{NCG} \cdot \eta_t \cdot \eta_g \cdot \eta_{TPL} \cdot \eta_{pipe} \quad (5.8)$$

$$\eta_{G(DH)} = \eta_{max} \cdot \eta_{pipe} \cdot \eta_{TPL} \quad (5.9)$$

$$\eta_{G(CHP)} = \eta_{max1} \cdot \eta_{NCG} \cdot \eta_t \cdot \eta_g \cdot \eta_{TPL} \cdot \eta_{pipe} \cdot \eta_{max2} \quad (5.10)$$

where  $\eta_{max1}$  represents the efficiency of conversion in ORC unit for electricity generation,  $\eta_{max2}$  is the efficiency of conversion of the remaining heat from the geothermal fluid for direct heat usage,  $\eta_t$  represents the turbine efficiency, and  $\eta_g$  is the efficiency of a generator.

The thresholds for the evaluation of the performance value  $x_{i,11}$  of alternative  $i$  for global efficiency criterion are shown in Table 5.25.

Table 5.25. Performance values  $x_{i,11}$  for the global efficiency criterion

Global efficiency [p.u.]	$\eta_G < 0.2$	$0.2 \leq \eta_G < 0.3$	$0.3 \leq \eta_G < 0.4$	$0.4 \leq \eta_G < 0.5$	$\eta_G \geq 0.5$
$x_{i,11}$	1	2	3	4	5

### 5.3.1.12. Wellhead temperature

Wellhead temperature represents the outlet temperature of the geothermal fluid at the wellhead and it is one of the main features of the geological site [21]. This temperature determines installed capacity, geothermal energy extraction technology, conversion efficiency, and consequently also influences costs and revenues. The main factors affecting the geothermal fluid temperature are production time, mass flow rate, geometry of wellbore,



annular filled material, thermal conductivity of cement, and geological conditions of surrounded formation [195]. In this method a simplified evaluation of wellhead temperature criterion was proposed since complex and extensive calculations, simulation scenarios and data are necessary to calculate the wellbore temperature. Namely, the value of this criterion is obtained as the ration of the wellhead temperature,  $T_H$  and reservoir temperature,  $T_{res}$ , thereby the wellhead temperature is evaluated by considering heat losses throughout wellbore. The wellhead temperature can either be estimated or calculated (in the case of geothermal project under development) or real measured data (in case of developed geothermal project, i.e., in case of an extension or upgrade of existing project). The thresholds for the evaluation of the performance value  $x_{i,12}$  of alternative  $i$  for wellhead temperature criterion are shown in Table 5.26.

Table 5.26. Performance values  $x_{i,12}$  for wellhead temperature criterion

Wellhead temperature [p.u.]	$\frac{T_H}{T_{res}} < 0.80$	$0.80 \leq \frac{T_H}{T_{res}} < 0.85$	$0.85 \leq \frac{T_H}{T_{res}} < 0.90$	$0.90 \leq \frac{T_H}{T_{res}} < 0.95$	$\frac{T_H}{T_{res}} \geq 0.95$
$x_{i,12}$	1	2	3	4	5

### 5.3.1.13. Flow rate

Parameters that impact the geothermal fluid flow performance are shown in Equation (5.11):

$$J = \frac{2 \cdot \pi \cdot k \cdot h}{B \cdot \mu \cdot (p_D + s)} (P_i - P_{wf}), \quad (5.11)$$

where  $k$  is the permeability of the rock ( $m^2$ ),  $h$  is formation thickness (m),  $B$  is the fluid formation volume factor ( $m^3/m^3$ ),  $\mu$  is the fluid viscosity ( $Pa \cdot s$ ),  $p_D$  is dimensionless pressure which is a function of dimensionless time and it depends on the flow model,  $s$  is the formation skin, and the  $(P_i - P_{wf})$  is the pressure difference (Pa) between the reservoir and the dynamic flowing pressure, that is the pressure gradient that causes the fluid flow [145].

To increase the fluid flow rate, it is necessary to lower the dynamic pressure. The pressure drawdown and fluid flow dependence are presented in [196] on the example of Svartsengi and Cerro Prieto geothermal fields where higher pressure drawdown resulted also in higher fluid flow rate.

In this method, empirical values of the pressure difference between reservoir pressure and dynamic pressure ( $dP$ ) are used to evaluate the performance  $x_{i,j}$  for alternative  $i$  for fluid flow rate criterion. Any value below the lower threshold presents a case that is unlikely to happen and any value above the upper threshold implies on a technologically unachievable

and economically unprofitable case. The thresholds to evaluate performance  $x_{i,13}$  of alternative  $i$  for flow rate criterion are showed in Table 5.27.

Table 5.27. Performance values  $x_{i,13}$  for fluid flow rate criterion

<b>Flow rate</b>					
<b>Pressure difference [MPa]</b>	$dP > 6$	$4.525 < dP \leq 6$	$3.05 < dP \leq 4.525$	$1.575 < dP \leq 3.05$	$0.1 < dP \leq 1.575$
$x_{i,13}$	1	2	3	4	5

#### 5.3.1.14. Injection temperature

Geothermal fluid reinjection is defined as returning of energy-depleted water (geothermal brine) back into the same hydraulically connected geothermal reservoir through a (re)injection well. Reinjection is nowadays considered as a highly important management strategy for any sustainable and environment-friendly geothermal site. The geothermal brine reinjection has many purposes as follows: the disposal of used wastewater that affects the environment; provision of additional recharge to geothermal reservoirs in order to prevent depletion; and to sustain the geothermal exploitation [197]. However, the reinjection wells should be placed far enough from the production wells to avoid thermal breakthrough which can cause several operational problems including: the power plant running below designed capacity; modification of field operations; and necessity of make-up water [198]. However, because every geothermal field contains unique geological setting and reservoir characteristics, it is hard to obtain the ‘optimum’ reinjection strategy [198]–[200].

There are several parameters related to the reinjection process that impact different aspects of a geothermal project. Namely, the results of an investigation performed on the lower geothermal reservoir in Soultz-sous-Forêts (i.e. 3.5 km to 5.4 km), showed that the fluid injection temperature had the strongest influence on the production temperature [201]. Furthermore, the injection pressure significantly impacts the cooling of the reservoir. Namely, lower injection temperature in interaction with lower injection pressure, yields maximum production temperature at the wellhead. Consequently, higher injection temperature in combination with higher injection pressure causes more rapid production wellhead temperature decline. This happens because the propagation of cold water is much slower under moderate and low pressure than under higher ones. However, if the reinjection is not managed properly, a high-pressure difference between the production and injection wells can induce early thermal breakthrough [145]. Well spacing is another frequently analysed influencing factor regarding heat extraction from an EGS [202]–[204]. A good reinjection

strategy requires the injection wells to be close enough to the production wells to provide pressure support, but far enough to prevent premature flooding by cold water, i.e. thermal breakthrough [199]. Nonetheless, it is important to note that while a wider spacing between wells tends to improve thermal performance by causing a slower decrease in production temperature and an increase in thermal breakthrough time [204], it also entails larger reservoir volumes, and conversely, smaller well spacing leads to reduced reservoir volumes [201]. Therefore, the well spacing must be optimized to achieve maximum possible reservoir size and production flow rate, and thus minimize the risk of early thermal breakthrough. This parameter is in the method evaluated using the qualitative terms since the well spacing is highly site specific. Additionally, scaling problems present technical obstacles if not managed properly. The geothermal fluid injected back into reservoir must not be cooled or depressurized to the extent that mineral precipitations (scales) will plug the reinjection pipelines, wells, and the pores and fractures in the target reinjection formation. Therefore, in this method it is proposed to evaluate this criterion by evaluating sub-criteria as following: (re)injection temperature, injection pressure, well spacing (distance between production and injection wells), and corrosion and scaling hazard. For this criterion to be applicable on a wide spectrum of geothermal projects and different end usages, the (re)injection temperature ( $T_{inj}$ ) ranges are defined in accordance with the reservoir temperature ( $T_{res}$ ). Overall evaluation of performance  $x_{i,14}$  of alternative  $i$  for injection temperature criterion is obtained as the sum,  $T_{inj,sum}$ , of the sub-grades  $x_{i,14,z}$  and the defined thresholds are shown in Table 5.28.

Regarding the open loop systems that discharge geothermal water at the surface instead of reinjecting it into the reservoir, the injection temperature criterion is evaluated using the maximum allowable water disposing temperature on surface (outlet brine temperature) that is legally prescribed for each country. The outlet brine temperature, i.e., the wastewater temperature has a direct impact on the various chemical and physical characteristics of water where it influences the development and growth of aquatic communities and other biological activity in terms of thermal pollution [205]. The evaluation of performance value  $x_{i,14}$  of alternative  $i$  for the injection temperature criterion, i.e., the outlet brine temperature ( $T_{out,b}$ ) is performed using the percentage of the maximum allowable water temperature for surface discharge ( $T_{max,a}$ ) defined for each country, as shown in Table 5.29.

Table 5.28. Performance values  $x_{i,14}$  for injection temperature criterion

<b>(Re)injection temperature</b> [°C]	$T_{inj} > \frac{3}{4} \cdot T_{res}$	$\frac{2}{3} \cdot T_{res} < T_{inj} \leq \frac{3}{4} \cdot T_{res}$	$\frac{1}{2} \cdot T_{res} < T_{inj} \leq \frac{2}{3} \cdot T_{res}$	$\frac{2}{5} \cdot T_{res} < T_{inj} \leq \frac{1}{2} \cdot T_{res}$	$T_{inj} \leq \frac{2}{5} \cdot T_{res}$
$x_{i,14,1}$	1	2	3	4	5
<b>Injection pressure</b> [-]	<i>high</i>	-	<i>moderate</i>	-	<i>low</i>
$x_{i,14,2}$	1	2	3	4	5
<b>Well spacing</b> [-]	<i>close</i>	-	<i>medium distant</i>	-	<i>distant</i>
$x_{i,14,3}$	1	2	3	4	5
<b>Scaling and corrosion hazard</b> [-]	<i>present</i>	-	<i>present but managed</i>	-	<i>not present</i>
$x_{i,14,4}$	1	2	3	4	5
<b>Injection temperature</b> [sum]	$4 \leq T_{inj,sum} < 7$	$7 \leq T_{inj,sum} < 10$	$10 \leq T_{inj,sum} < 13$	$13 \leq T_{inj,sum} < 16$	$16 \leq T_{inj,sum} \leq 20$
$x_{i,14}$	1	2	3	4	5

Table 5.29. Performance value  $x_{i,14}$  for an open loop system for outlet brine temperature (under injection temperature criterion)

<b>Outlet brine temperature</b> [°C]	$T_{out,b} \geq 0.8 \cdot T_{max,a}$	$0.8 \cdot T_{max,a} < T_{out,b} \leq 0.7 \cdot T_{max,a}$	$0.7 \cdot T_{max,a} < T_{out,b} \leq 0.6 \cdot T_{max,a}$	$0.6 \cdot T_{max,a} < T_{out,b} \leq 0.5 \cdot T_{max,a}$	$T_{out,b} < 0.5 \cdot T_{max,a}$
$x_{i,14}$	1	2	3	4	5

### 5.3.1.15. Levelized cost of energy (LCOe)

The average cost of energy related project over the lifetime of the project is commonly addressed by the levelized cost of energy (LCOe) [144]. Depending on the end usage application this LCOe is calculated as levelized cost of electricity (LCOE) in case when the electricity is generated (Equation (5.12)) or levelized cost of heat (LCOH) heat energy is produced (Equation (5.13)). In case of CHP production, depending on the user specified preferred main product both the LCOE and LCOH are calculated. Namely, the LCOE calculated according to Equation (5.14) is used if the main product is electricity, and the LCOH calculated according to Equation (5.15). is used if the main product is heat. It should be noted that when calculating the LCOE for a CHP plant, the revenues for heat sales must be deducted. Similarly, when calculating the LCOH for a CHP plant, the revenues for electricity sales must be deducted.

$$LCOE = \frac{\sum_{t=1}^T \frac{I_t - S_t}{(1+r)^t} + \sum_{t=1}^T \frac{OM_t \cdot (1-TR)}{(1+r)^t} - \sum_{t=1}^{TD} \frac{DEP_t \cdot TR}{(1+r)^t} - \frac{RV}{(1+r)^T}}{\sum_{t=1}^T \frac{EE_t}{(1+r)^t}} \quad (5.12)$$

$$LCOH = \frac{\sum_{t=1}^T \frac{I_t - S_t}{(1+r)^t} + \sum_{t=1}^T \frac{OM_t \cdot (1-TR)}{(1+r)^t} - \sum_{t=1}^{TD} \frac{DEP_t \cdot TR}{(1+r)^t} - \frac{RV}{(1+r)^T}}{\sum_{t=1}^T \frac{EH_t}{(1+r)^t}} \quad (5.13)$$

$$\begin{aligned} & LCOE(chp) \\ &= \frac{\sum_{t=1}^T \frac{I_t - S_t}{(1+r)^t} + \sum_{t=1}^T \frac{OM_t \cdot (1-TR)}{(1+r)^t} - \sum_{t=1}^{TS} \frac{RHS_t \cdot (1-TR)}{(1+r)^t} - \sum_{t=TS+1}^T \frac{RHM_t \cdot (1-TR)}{(1+r)^t} - \sum_{t=1}^{TD} \frac{DEP_t \cdot TR}{(1+r)^t} - \frac{RV}{(1+r)^T}}{\sum_{t=1}^T \frac{EE_t}{(1+r)^t}} \end{aligned} \quad (5.14)$$

$$\begin{aligned} & LCOH(chp) \\ &= \frac{\sum_{t=1}^T \frac{I_t - S_t}{(1+r)^t} + \sum_{t=1}^T \frac{OM_t \cdot (1-TR)}{(1+r)^t} - \sum_{t=1}^{TS} \frac{RES_t \cdot (1-TR)}{(1+r)^t} - \sum_{t=TS+1}^T \frac{REM_t \cdot (1-TR)}{(1+r)^t} - \sum_{t=1}^{TD} \frac{DEP_t \cdot TR}{(1+r)^t} - \frac{RV}{(1+r)^T}}{\sum_{t=1}^T \frac{EH_t}{(1+r)^t}} \end{aligned} \quad (5.15)$$

In the Equations 5.12 - 5.15,  $T$  represents the lifetime of the project,  $I_t$  annualized investment costs in year  $t$ ,  $S_t$  incentives or subsidies in year  $t$ ,  $r$  the nominal discount factor,  $OM_t$  operation and maintenance costs in year  $t$ ,  $TR$  effective tax rate,  $DEP_t$  depreciation in year  $t$ ,  $RV$  residual value in year  $t$ ,  $EE_t$  generated electricity in year  $t$ ,  $EH_t$  generated heat in year  $t$ , and  $TD$  duration of depreciation period. Additionally, for the case of CHP production mode, in the Equations 5.14 - 5.15. additional parameters are introduced. Namely,  $RHS_t$  represents revenues from subsidized heating power sales in year  $t$ ,  $RHM_t$  revenues from the market heating power sales in year  $t$ ,  $RES_t$  revenues from subsidized electricity sales in year  $t$ ,  $REM_t$  revenues from the market electricity sales in year  $t$ , and  $TS$  duration of subsidized price or electricity of heating power.

Performance value  $x_{i,15}$  of alternative  $i$  for the LCOe criterion is determined based on the  $LCOe/\bar{\pi}$  ratio measured in p.u., where  $\bar{\pi}$  represents the average market electricity price of electricity when LCOE is used, and average market price of natural gas when LCOH is used. Average market price of natural gas is used since neither International Energy Agency nor Eurostat collect the data of national average district heating prices in Europe. However, used data is similar to the calculated data from the methodology in [206] since there is a strong correlation of heating price to the fossil fuel prices because in many district heating systems the heat supply is still based on fossil fuels [145]. The thresholds for the performance values  $x_{i,15}$  are given in Table 5.30.

Table 5.30. Performance values  $x_{i,15}$  for LCOe criterion

Ratio [p.u.]	$1 \leq \frac{LCOe}{\bar{\pi}} < \infty$	$0.8 \leq \frac{LCOe}{\bar{\pi}} < 1$	$0.6 \leq \frac{LCOe}{\bar{\pi}} < 0.8$	$0.4 \leq \frac{LCOe}{\bar{\pi}} < 0.6$	$0 \leq \frac{LCOe}{\bar{\pi}} < 0.4$
$x_{i,15}$	1	2	3	4	5

### 5.3.1.16. Net present value (Equivalent annual annuity)

One of the primary figures of merit when evaluating financial attractiveness of a electricity generation project is the net present value (NPV) [97], [132], [207]–[210]. The NPV method is a valuable indicator because it considers the time value of money, and it is calculated as the sum of discounted after-tax cash flows throughout all the years of the project. Projects that yield positive NPV are attractive to potential investors. The NPV of each project is calculated according to the Equation (5.16):

$$NPV = \sum_{t=0}^T a_t \cdot S_{cf,t} = \frac{S_{cf,0}}{(1+r)^0} + \frac{S_{cf,1}}{(1+r)^1} + \dots + \frac{S_{cf,T}}{(1+r)^T} , \quad (5.16)$$

where  $S_{cf,t}$  represents the balance of cash flow (inflows minus outflows) at the time  $t$ ,  $a_t$  is the financial discount factor chosen for discount at the time  $t$  and  $r$  is the nominal discount factor.

However, for this criterion to be representative and applicable for different scenarios and alternatives it should be further modified in a way to be suitable to compare projects with unequal lifetimes. For this purpose, the equivalent annual annuity (EAA) approach is mostly used. It is an approach used in capital budgeting to choose between mutually exclusive projects with unequal useful lifetimes. In this method it is assumed that the projects are represented with annuities. Namely, the after the NPV is calculated (as shown in Equation 5.16) the annual cash flows are available. Those annual cash flows, when discounted at the relevant discount rate for the lifetime of the relevant project, are equal to the NPV of the project. Therefore, the EAA approach used in this criterion consist of three steps: i) calculation of NPV of each project (alternative) under consideration, ii) calculation of each project's EAA, and iii) each project's EAA is compared. The project with the highest EAA is considered as best option, i.e., project with higher EAA is more preferable. The EAA is calculated as shown in Equation (5.17).

$$EAA = \frac{NPV \cdot r}{1 - (1+r)^{-n}} , \quad (5.17)$$

where  $NPV$  is the calculated net present value (€),  $r$  is the discount rate for the period (%/100) and  $n$  is the number of periods (years).

In case of only one alternative, the performance values of NPV(EAA) criterion can be assessed with either 1, if the EAA is less than zero, or 5 if the EAA is greater than zero. If multiple alternatives are evaluated, the ranges thresholds are defined in ascending order. Namely, the alternative with the highest EAA is assessed with value 5, and other options in ascending order, i.e., alternative with second highest EAA is assessed with value 4 and in similar manner for all other alternatives. It is also assumed that not more than 5 projects are being compared, however, the methodology can be adapted for more than 5 projects if needed. Additionally, when comparing more alternatives, regardless of the number of the alternatives, if the project has EAA less than zero it is evaluated with value 1. The thresholds for performance values  $x_{i,16}$  of alternative  $i$  for NPV(EAA) criterion are given in Table 5.31.

Table 5.31. Performance values  $x_{i,16}$  for NPV(EAA) criterion

EAA					
[€]					
One option	$EAA < 0$	-	-	-	$EAA \geq 0$
More options	$EAA < EAA_{max4}$ or $EAA < 0$	$EAA_{max4} < EAA \leq EAA_{max3}$	$EAA_{max3} < EAA \leq EAA_{max2}$	$EAA_{max2} < EAA \leq EAA_{max1}$	$EAA = EAA_{max1}$
	$x_{i,16}$	1	2	3	4

### 5.3.1.17. Capital costs

The capital costs criterion is used to evaluate investment costs that occur in different phases of geothermal project. Namely, as described in [144], [174], geothermal project could generally be divided into eight phases with different duration. These eight key-development phases could be compressed into following phases: permitting, exploration, drilling, construction of power plant and operation phase. Moreover, capital, i.e. investment costs are related to first four phases and according to [53] and they mainly consist of costs for reservoir exploration, well drilling and completion, reservoir engineering measures, installation of the geothermal fluid loop, and construction of the plant on the surface for power and/or heat provision alongside with the grid connection costs.

Capital costs, i.e., capital expenditures (CAPEX), are usually measured and represented in euros or USD per installed kilo-watt (€/kW) [114], [115], [211]–[217]. The year-on-year variations in installed costs are quite significant since the market for geothermal power is relatively thin. In 2019, the global weighted average cost of installed capacity for power plants was 3,916 \$/kW, down from the 4,171 \$/kW recorded in 2018 but up from the 2,588

\$/kW reported in 2010 [217]. The thresholds to evaluate performance of alternative  $i$  for the capital costs criterion are determined based on the various sets of data. Data from International Renewable Energy Agency (IRENA) available in [216] include capital costs of different types technologies (binary, flash, direct steam, enhanced and hybrid) and capacities. However, based on this data solely it is not possible to distinguish which projects could be classified as deep geothermal projects. Therefore additional literature was used [20], [73], [218], [219]. Namely, data available in [73] includes capital costs estimations for three cases of resource grade (low-, medium-, and high-grade resource corresponding to a geothermal gradient of 30, 50, and 70 °C/km, respectively), in combination with three levels of technological maturity (today's, mid-term, and commercially mature technology corresponding to a productivity of 30, 50, and 70 kg/s per production well and thermal drawdown rate of 2%, 1.5%, and 1%). In [219] the authors stated that the EGS costs could not yet be assessed accurately due to the limited experience available which is mainly based on the pilot plants and projects. The cost range for the year 2030 is estimated to be between 6,600 and 20,000 \$/kW. In [220] the base year estimate of CAPEX for deep EGS binary plants is around 35,000 \$/kW and future year projection of CAPEX for such plants is approximated at 30,000 \$/kW.

Capital costs for direct heat use are significantly smaller than for the electricity generation. The direct heat use project costs have a wide range, depending upon specific use, temperature and required flow rate [221]. Estimated capital costs for geothermal district heating are between 1,500 €/kW<sub>th</sub> and 1,800 €/kW<sub>th</sub>, and for other direct geothermal uses between 500 €/kW<sub>th</sub> and 1,500 €/kW<sub>th</sub> [222].

The power plant capital costs for CHP plant consist of power plant part costs and direct heat use plant part costs. The surface direct heat use plant costs are in the literature not always specifically provided and they significantly differ in values [223].

Costs related to heating distribution network or power grid depend highly on the end-use application (industrial, district heating, agriculture, greenhouses etc.). Other capital costs related to exploration, drilling, reservoir stimulation etc., highly depend upon the starting point of the project, i.e., if the project is a greenfield or a brownfield project.

The thresholds for performance value  $x_{i,17}$  of alternative  $i$  for capital costs criterion (Table 5.32) are defined based on the above-mentioned literature sources and any future predictions found in public domain. The thresholds for capital costs,  $cc$ , for each end user option are shown in Table 5.32. The thresholds for CHP capital costs are defined as the capital costs of



electricity generation increased by 40% which represents the costs for surface direct-use heat plant (all other capital costs are included in the electricity generation capital costs).

Table 5.32. Performance values  $x_{i,17}$  for capital costs criterion

Capital costs [€/kW]					
<i>Electricity generation</i>	$cc > 20,000$	$10,000 < cc \leq 20,000$	$7,000 < cc \leq 10,000$	$5,000 < cc \leq 7,000$	$cc \leq 5,000$
<i>Direct usage</i>	$cc > 1,800$	$1,500 < cc \leq 1,800$	$1,200 < cc \leq 1,500$	$900 < cc \leq 1,200$	$cc \leq 900$
<i>CHP</i>	$cc > 28,000$	$14,000 < cc \leq 28,000$	$9,800 < cc \leq 14,000$	$7,000 < cc \leq 9,800$	$cc \leq 7,000$
$x_{i,17}$	1	2	3	4	5

### 5.3.1.18. Operation and maintenance costs (O&M costs)

Operation and maintenance costs (O&M) are another most used economic criteria [118], [214], [215], [224]–[228]. For geothermal energy projects, the estimates are based upon plant size and the type of energy conversion system used. Usually, the O&M costs are divided into fixed and variable O&M costs. Fixed O&M costs (€) are not connected to the amount of produced energy and variable O&M costs (€/kWh) are directly depended on the amount of produced energy. However, many reports integrate the fixed costs into variable costs, hence one value of O&M costs is expressed in €/kWh. Furthermore, when geothermal projects are assessed, the O&M costs usually include annual labour costs, annual power plant maintenance cost, wells/reservoir maintenance costs, gathering system maintenance costs, make-up water costs, and production pump maintenance and replacement costs. For O&M costs related to electricity generation from EGS, the authors in [89] used range of values typically observed in the geothermal industry, i.e. from 0.02 to 0.035 €/kWh. However, according to authors, the unit O&M costs of an EGS project should be somewhat less than of a conventional geothermal project due to more controlled and optimized production/injection operation, absence of make-up well drilling, and relatively small number of well workovers expected in an EGS operation. However, it is not uncommon that the O&M costs are taken also as percentage of capital costs. In [73] the O&M costs are conservatively taken as 5% of total capital cost per year. Therefore, since the O&M costs are influenced by many different parameters and they consist of different segments, the thresholds for O&M costs criterion in this method are defined based on the aforementioned literature sources. The thresholds for evaluation of performance value  $x_{i,18}$  of alternative  $i$  for O&M costs defined in Table 5.33 are defined as 3% of capital costs for each end usage mode. Additionally, an average capacity

factor of 90% is used for the electricity generation, 50% for direct heat usage, and 40% for CHP.

Table 5.33. Performance values  $x_{i,18}$  for O&M costs criterion

O&M costs					
[€/kWh]					
Electricity generation	O&M	$0.038 < O\&M$	$0.027 < O\&M$	$0.019 < O\&M$	O&M
	$> 0.076$	$\leq 0.076$	$\leq 0.038$	$\leq 0.027$	$\leq 0.019$
Direct usage	O&M	$0.010 < O\&M$	$0.008 < O\&M$	$0.006 < O\&M$	O&M
	$> 0.012$	$\leq 0.012$	$\leq 0.010$	$\leq 0.008$	$\leq 0.006$
CHP	O&M	$0.120 < O\&M$	$0.084 < O\&M$	$0.060 < O\&M$	O&M
	$> 0.240$	$\leq 0.240$	$\leq 0.120$	$\leq 0.084$	$\leq 0.060$
$x_{i,18}$	1	2	3	4	5

### 5.3.1.19. Discounted payback period

Another frequently used economic criterion is the discounted payback period (DPP) [97], [132], [193], [207], [211], [229], [230]. The DPP is recommended when significant uncertainties are present as it allows a quick assessment of the period during which an investor's capital is at risk [231]. The discounted payback period is derived from the equation for NPV [207]:

$$DPP = \frac{-\ln(1 - r \cdot \frac{S_0}{S_{cf}})}{\ln(1 + r)}, \quad (5.18)$$

where  $S_0$  represents the initial investment cost of implementing the system, usually considered to take place in year 0,  $S_{cf}$  is future periodic cash flow from energy production and  $r$  is the nominal discount factor.

However, the Equation (5.18) needs to be modified for the projects that do not generate even cash flows, as it is assumed in Equation (5.18). Therefore, for projects that generate inconsistent or uneven cash flows the following Equation (5.19) should be used:

$$DPP = t_l + \frac{\frac{|I_{t_l}^{cum}|}{(1+r)^{t_l}}}{\frac{I_{t_l+1}}{(1+r)^{t_l+1}}}, \quad (5.19)$$

where  $t_l$  represents the last year (period) with a negative discounted cumulative cash flow, i.e. number of years before full recovery,  $I_{t_l}^{cum}$  is absolute value of cumulative cash flow at the end of the year  $t_l$ ,  $I_{t_l+1}$  is cash flow during the year after  $t_l$ ,  $(1+r)^{t_l}$  and  $(1+r)^{t_l+1}$  are present value factors for year  $t_l$  and  $t_l + 1$ , respectively.

Investments with shorter payback periods are more appealing. In case of only one alternative being evaluated, the project is acceptable if the DPP is shorter than the project's lifetime or some fixed period. Therefore, in this method for this case the performance value for DPP criterion  $x_{i,19}$  can be assessed with values 1, if the DPP is longer than the economic lifetime of the project, 3 if the DPP is shorter than the economic lifetime of the project, and with 5 if the DPP is shorter than the half of the economic lifetime of the project. In multiple alternatives are evaluated (and consequently compared) the ranges thresholds are defined in ascending order. Namely, the alternative with the shortest DPP is assessed with value 5 ( $DPP_{best1}$ ), and other options in ascending order, i.e., alternative with second shortest DPP is assessed with value 4 and in similar manner for all other alternatives. It is also assumed that not more than 5 projects are being compared. However, the methodology can easily be adapted to extend possible comparison to more than 5 projects simultaneously. Additionally, when comparing more alternatives, regardless of the number of the alternatives, if the project's DPP is less than the economic lifetime of the project it is evaluated with value 1. The thresholds for performance value  $x_{i,19}$  of alternative  $i$  for DPP criterion are shown in Table 5.34.

Table 5.34. Performance values  $x_{i,19}$  for DPP criterion

Discounted payback period [years]					
<i>One option</i>	$DPP > econom. life$	-	$DPP < econom. life$	-	$DPP < \frac{1}{2} econom. life$
<i>More options</i>	$DPP > DPP_{best4}$ or $DPP > econom. life$	$DPP_{best3} < DPP$ $\leq DPP_{best4}$	$DPP_{best2} < DPP$ $\leq DPP_{best3}$	$DPP_{best1} < DPP$ $\leq DPP_{best2}$	$DPP = DPP_{best1}$
$x_{i,19}$	1	2	3	4	5

### 5.3.1.20. Support schemes

Geothermal projects are highly capital intensive and have great levels of uncertainties on the availability of the resource. As such they generally need public support to be economically viable, especially in the early project development stages. The progression on the EGS technology learning curve highly depends on public policies and different support schemes. However, as presented in Chapter 2, Section 2.4.4. there are still strong barriers and challenges in this regard. Support schemes should nonetheless be temporary and be phased out as the technology reaches full competitiveness [232]. The instruments and incentives to bring favourable conditions for geothermal development are RD&I support, investment grants, operational support schemes (e.g. Feed-in Tariff, Feed-in Premium, quota systems,

green certificates etc.), insurance schemes (i.e. geological risk coverage), and additional measures (i.e. tax exemptions, fiscal incentives etc.) [222], [232]. Many of abovementioned support schemes are available for electricity generation and/or direct heat use from geothermal energy, but they differ in the amount and the duration of the support, varying from country to country [232], [233]. With the progression of the geothermal market towards the maturity, it is possible that the support system and framework are to be totally relinquished to the market dynamics [234]. Still, at the early stages of market maturity, the role of public sector and support is crucial. To evaluate the performance value  $x_{i,20}$  of alternative  $i$  for support schemes criterion, linguistic terms are used as shown in Table 5.35.

Table 5.35. Performance values  $x_{i,20}$  for support schemes criterion

Support schemes	$x_{i,20}$
No available and applicable support schemes whatsoever.	1
Only RD&I support available.	2
Beside the RD&I support the operation support schemes are available.	3
Available investment grants, operational support schemes and RD&I support, but no insurance schemes.	4
Availability and applicability of all or most of the support schemes: RD&I support, investment grants, operational support schemes (e.g., Feed-in Tariff, Feed-in Premium, quota systems, green certificates etc.), insurance schemes (i.e., geological risk coverage), and any additional measures (i.e., tax exemptions, fiscal incentives etc.)	5

#### 5.3.1.21. Job creation

Geothermal projects have great impact on local communities as they are often built in proximity to the local energy needs. Therefore, the activities regarding exploration, resource development, power plant construction, and O&M are mainly covered by local workforce. Employment potential can be divided into direct, indirect and included employment effect and quantified in terms of full-time jobs/MW (FT) and person\*years of construction and manufacturing employment [144]. Total direct, indirect, and induced employment ratio is a ratio of the installed capacity,  $P_{inst.}$  (MW) and full-time jobs ( $e_{FT}$ ) calculated as defined in Equation (5.20). Additionally, Equation (5.21) represents construction and manufacturing employment (C&M) ( $e_{C\&M}$ ), where those jobs are expressed as full-time positions over one year (person\*year) as a function of installed capacity,  $P_{inst}$  in [MW]. However, those C&M jobs are spread over several years considering the development time frame for the new geothermal energy projects. The thresholds (Table 5.36) for total performance value  $x_{i,21}$  of alternative  $i$  for job creation criterion are in this method defined based on the calculated average ( $AV$ ) of grades associated to FT,  $x_{i,21,1}$ , and C&M sub-factors  $x_{i,21,2}$ .

$$FT\ jobs = \log_{1.068}(P_{inst.}) \quad (5.20)$$

$$C\&M \text{ jobs} = 22.4 \cdot P_{inst}. \quad (5.21)$$

Table 5.36. Performance values  $x_{i,21}$  for job creation criterion

<b>Employment FT</b> [ $\frac{dFT}{dP_{inst}}$ ]	$e_{FT} < 1$	$1 \leq e_{FT} < 1.5$	$1.5 \leq e_{FT} < 2$	$2 \leq e_{FT} < 4$	$e_{FT} \geq 4$
$x_{i,21,1}$	1	2	3	4	5
<b>Employment C&amp;M</b> [ $person \times year$ ]	$e_{C\&M} \leq 50$	$50 < e_{C\&M} \leq 150$	$150 < e_{C\&M} \leq 250$	$250 < e_{C\&M} \leq 350$	$e_{C\&M} > 350$
$x_{i,21,2}$	1	2	3	4	5
<b>Job creation</b>	$AV \leq 1$	$1 < AV \leq 2$	$2 < AV \leq 3$	$3 < AV \leq 4$	$4 < AV \leq 5$
$x_{i,21}$	1	2	3	4	5

### 5.3.1.22. Social acceptability

Social acceptability criterion is qualitative criterion that expresses the degree of acceptance of hypothetical realization of the project under review by the local community [191]–[193], [235]. The social acceptability level also highly depends on the size of the project and potential benefit of proposed geothermal project [236]–[240]. The thresholds for evaluation of performance value  $x_{i,22}$  of alternative  $i$  for social acceptability criterion are shown in Table 5.37. Since this criterion is qualitative criterion, the thresholds are expressed in linguistical terms.

Table 5.37. Performance values  $x_{i,22}$  for social acceptability criterion

<b>Social acceptability</b>	$x_{i,22}$
Lack of trust related to prior negative experiences with geothermal projects; NIMBY <sup>1</sup> syndrome.	1
Lack of education related to geothermal energy which brings scepticism about geothermal project. Highly unlikely that the project will be accepted.	2
Some concerns about the potential risks, but community is willing to consider geothermal project. However, the opinion of the population is divided.	3
Enough knowledge about geothermal project and the majority accepts the installation, however only small part of the community has direct benefits.	4
The majority is in favour of the installation since most of the local community has direct benefits from the geothermal project.	5

<sup>1</sup>NIMBY syndrome – „not in my back yard”; is a characterization of opposition by residents to proposed developments in their local area, as well as support for strict land use regulations.

### 5.3.1.23. Land use

Like other power plants, the geothermal power plants occupy certain area of the land. Geothermal power plants are typically constructed directly at the geothermal field site due to the challenges posed by expensive pipelines and the potential for substantial pressure and temperature reductions during the long-distance transportation of hot geothermal brine. Geothermal power plants occupy very small land area compared to other sources of

electricity, especially compared to other renewable energy sources [241]. The impact on the landscape in this method is measured as land use intensity ( $LUI$ ) for installed power in ( $m^2/kW$ ), and the ranges for evaluation of performance value  $x_{i,23}$  of alternative  $i$  for land use criterion was estimated according to [242] and shown in Table 5.38.

Table 5.38. Performance values  $x_{i,23}$  for land use criterion

Land use [ $m^2/kW$ ]	$LUI > 40$	$40 \geq LUI > 30$	$30 \geq LUI > 20$	$20 \geq LUI > 10$	$LUI \leq 10$
$x_{i,23}$	1	2	3	4	5

#### 5.3.1.24. Noise

The noise during a geothermal project can occur in different development stages such as exploration phase, drilling phase, and operational phase. Drilling involves usage of large size mud pumps, compressors, hydraulic pumps and generators, and the drilling operations are usually carried out on a 24-hour basis. Therefore, the noise during the night in the drilling phase represent an notable impact but is usually not an issue for the distances from the facility above more than 500-700 m. The noise impact during routine operation is mainly caused by cooling towers and power transformers, and typical acceptable levels are 71-83 dB at 900 meters distance from the facility [38]. For the binary power plants, used in EGS project, the cooling towers (air-cooling condensers) can represent significant noise. Based on those levels the thresholds for evaluation of performance value  $x_{i,24}$  of alternative  $i$  for noise criterion were determined as shown in Table 5.39. The  $n_{dB}$  represent either measured or estimated noise level (dB) during the operational period of the geothermal power plant.

Table 5.39. Performance values  $x_{i,24}$  for noise criterion

Noise [dB]	$n_{dB} \geq 100$	$100 > n_{dB} \geq 90$	$90 > n_{dB} \geq 80$	$80 > n_{dB} \geq 70$	$n_{dB} < 70$
$x_{i,24}$	1	2	3	4	5

#### 5.3.1.25. Avoided $CO_2$ emissions

To evaluate the energy project sustainability aspects and its environmental impact, the  $CO_2$  emissions are an important criteria [26], [132], [209], [229], [243]–[246]. Additionally, the carbon dioxide equivalent ( $CO_2$ -eq.) indicates global warming, expressing the amount of carbon dioxide that causes the same global warming as some amount of another gas. Therefore, to evaluate one aspect of environmental impact of a geothermal (EGS) project, the avoided  $CO_2$  emissions criterion has been established. Namely, the criterion represents the  $CO_2$  emissions that have been avoided by energy generation from an EGS facility instead of

energy generation based on the reference electricity mix and reference heat mix. The reference electricity mix represents business-as-usual development until 2019, and reference heat mix is based on a mix of single combustion application [26]. The avoided CO<sub>2</sub>-equivalent emissions can be calculated according to the modified equation from [246]:

$$E_{CO_2} = \sum_{p=1}^{t_{op}} (\dot{E}_p \cdot e_{CO_2,elemix} + \dot{Q}_p \cdot e_{CO_2,heatmix}), \quad (5.22)$$

where  $t_{op}$  represents the duration of the operational phase of the plant,  $\dot{E}_p$  is the net electricity production by system at the operating conditions of period  $p$  (MWh<sub>e</sub>),  $\dot{Q}_p$  is the produced heat energy to cover heating requirement during period  $p$  (MWh<sub>th</sub>),  $e_{CO_2,elemix}$  and  $e_{CO_2,heatmix}$  are the specific CO<sub>2</sub> emissions of electricity or heat production from the reference electricity mix (kgCO<sub>2</sub>/MWh<sub>e</sub>) and for heating production from a heat mix (kgCO<sub>2</sub>/MWh<sub>th</sub>), respectively.

The default reference electricity and heat mix are country specific and based on the business-as-usual development until 2019 in each country. From Equation (5.22) it is obvious that the amount of avoided CO<sub>2</sub>-equivalent emissions is in correlation with the produced energy, fossil fuel mix and corresponding emission factors of fossil fuels. Since it is somewhat difficult to define the thresholds for the exact amount of avoided emissions (in kilograms or tons), the approach proposed in this method is to evaluate each of the parameters from the Equation (5.22). The overall grade for the avoided CO<sub>2</sub>-equivalent emissions criterion consists of grading the following sub-criteria: capacity factor, fossil fuel mix, and emission factor. Finally, based on the sum of those sub-grades the thresholds for this criterion are determined.

The capacity factor performance value  $x_{i,25,1}$  reflects the produced electricity, heat energy, or both in case of the CHP production plant. The higher the capacity factor, the better the grade since the production is closer to the maximum possible production for the installed capacity. The ranges for this sub-criterion are established in Section 5.3.1.8. and are here taken without further modifications.

Fossil fuel mix grade consists of grading the share of each fossil fuel (coal, oil, and natural gas,  $C_{share}$ ,  $O_{share}$ , and  $NG_{share}$ , respectively) and summing those grades into one ( $FF_{mix}$ ). The ranges are defined based on the fossil fuel share data for EU28 countries for different production modes (only electricity generation, only heat production, and CHP production).

The ranges for grading the fossil fuel mix are obtained to reflect the sum of grades for each fossil fuel [145].

Emission factor grade is the third part of the overall grade for this criterion. It consists of grading emission factors of each fossil fuel ( $C_{ef}$ ,  $O_{ef}$ , and  $NG_{ef}$ ) and summing those sub-grades ( $EF$ ). The ranges are defined based on the emission factors data for EU28 countries for different production modes [145]. Sub-criteria fossil fuel mix ( $x_{i,25,2}$ ) and emission factor ( $x_{i,25,3}$ ) are graded separately based on the grades for each fossil fuel share and emission factor as shown in Equation (5.23) and Equation (5.24):

$$x_{i,25,2} = x_{i,25,2,1} + x_{i,25,2,2} + x_{i,25,2,3} \quad (5.23)$$

$$x_{i,25,3} = x_{i,25,3,1} + x_{i,25,3,2} + x_{i,25,3,3} \quad (5.24)$$

The thresholds for evaluation of performance value  $x_{i,25}$  of alternative  $i$  for avoided CO<sub>2</sub> emissions for all three production alternatives are given in Table 5.40 (only electricity generation), Table 5.41(only heating power production), and Table 5.42 (CHP). The overall performance value  $x_{i,25}$  of alternative  $i$  for avoided CO<sub>2</sub> emissions criterion ( $CO_2$ ) is calculated as the sum of the performance values (grades) for each sub-criterion, i.e. capacity factor ( $x_{i,25,1}$ ), fossil fuel mix ( $x_{i,25,2}$ ) and emission factor ( $x_{i,25,3}$ ) as shown in Equation (5.25).

$$x_{i,25} = x_{i,25,1} + x_{i,25,2} + x_{i,25,3} \quad (5.25)$$

Table 5.40. Performance values  $x_{i,25}$  for avoided CO<sub>2</sub> emissions criterion for only electricity generation

<b>Capacity factor</b>	grade from the Capacity criterion (see Table 5.20.)				
$x_{i,25,1}$	1	2	3	4	5
<b>Fossil fuel mix</b>					
[p.u.]					
<i>Coal share</i>	$C_{share} \leq 0.13$	$0.13 < C_{share} \leq 0.34$	$0.34 < C_{share} \leq 0.57$	$0.57 < C_{share} \leq 0.85$	$C_{share} > 0.85$
$x_{i,25,2,1}$	1	2	3	4	5
<i>Oil share</i>	$O_{share} \leq 0.01$	$0.01 < O_{share} \leq 0.05$	$0.05 < O_{share} \leq 0.17$	$0.17 < O_{share} \leq 0.92$	$O_{share} > 0.92$
$x_{i,25,2,2}$	1	2	3	4	5
<i>Natural gas share</i>	$NG_{share} > 0.91$	$0.62 < NG_{share} \leq 0.91$	$0.31 < NG_{share} \leq 0.62$	$0.09 < NG_{share} \leq 0.31$	$NG_{share} \leq 0.09$
$x_{i,25,2,3}$	1	2	3	4	5
$FF_{mix}$	$3 \leq FF_{mix} < 5,4$	$5,4 \leq FF_{mix} < 7,8$	$7,8 \leq FF_{mix} < 10,2$	$10,2 \leq FF_{mix} < 12,6$	$12,6 \leq FF_{mix} \leq 15$
$x_{i,25,2}$	1	2	3	4	5



Table 5.40. (continued) Performance values  $x_{i,25}$  for avoided CO<sub>2</sub> emissions criterion for only electricity generation

<b>Emission factor</b>					
[gCO <sub>2</sub> /kWh]					
<i>Coal</i>	$C_{ef} \leq 998.72$	$998.72 < C_{ef} \leq 1048.40$	$1,048.40 < C_{ef} \leq 1072.98$	$1,072.98 < C_{ef} \leq 1266.61$	$C_{ef} > 1,266.61$
$x_{i,25,3,1}$	1	2	3	4	5
<i>Oil</i>	$O_{ef} \leq 676.70$	$676.70 < O_{ef} \leq 789.41$	$789.41 < O_{ef} \leq 901.02$	$901.02 < O_{ef} \leq 1,088.44$	$O_{ef} > 1,088.44$
$x_{i,25,3,2}$	1	2	3	4	5
<i>Natural gas</i>	$NG_{ef} \leq 318.15$	$318.15 < NG_{ef} \leq 334.06$	$334.06 < NG_{ef} \leq 344.46$	$344.46 < NG_{ef} \leq 380.36$	$NG_{ef} > 380.36$
$x_{i,25,3,3}$	1	2	3	4	5
<i>EF</i>	$3 \leq EF < 5,4$	$5,4 \leq EF < 7,8$	$7,8 \leq EF < 10,2$	$10,2 \leq EF < 12,6$	$12,6 \leq EF \leq 15$
$x_{i,25,3}$	1	2	3	4	5
<b>Avoided CO<sub>2</sub> emissions</b>	$3 \leq CO_2 < 5,4$	$5,4 \leq CO_2 < 7,8$	$7,8 \leq CO_2 < 10,2$	$10,2 \leq CO_2 < 12,6$	$12,6 \leq CO_2 \leq 15$
<b>[-]</b>					
$x_{i,25}$	1	2	3	4	5

Table 5.41. Performance values  $x_{i,25}$  for avoided CO<sub>2</sub> emissions criterion for only heat production

<b>Capacity factor</b>					
grade from the Capacity criterion (see Table 5.20.)					
$x_{i,25,1}$	1	2	3	4	5
<b>Fossil fuel mix</b>					
[p.u.]					
<i>Coal share</i>	$C_{share} \leq 0.04$	$0.04 < C_{share} \leq 0.19$	$0.19 < C_{share} \leq 0.36$	$0.36 < C_{share} \leq 0.70$	$C_{share} > 0.70$
$x_{i,25,2,1}$	1	2	3	4	5
<i>Oil share</i>	$O_{share} \leq 0.01$	$0.01 < O_{share} \leq 0.02$	$0.02 < O_{share} \leq 0.09$	$0.09 < O_{share} \leq 0.19$	$O_{share} > 0.19$
$x_{i,25,2,2}$	1	2	3	4	5
<i>Natural gas share</i>	$NG_{share} > 0.89$	$0.64 < NG_{share} \leq 0.89$	$0.35 < NG_{share} \leq 0.64$	$0.15 < NG_{share} \leq 0.35$	$NG_{share} \leq 0.15$
$x_{i,25,2,3}$	1	2	3	4	5
<i>FF<sub>mix</sub></i>	$3 \leq FF_{mix} < 5,4$	$5,4 \leq FF_{mix} < 7,8$	$7,8 \leq FF_{mix} < 10,2$	$10,2 \leq FF_{mix} < 12,6$	$12,6 \leq FF_{mix} \leq 15$
$x_{i,25,2}$	1	2	3	4	5
<b>Emission factor</b>					
[gCO <sub>2</sub> /kWh]					
<i>Coal</i>	$C_{ef} \leq 298.75$	$298.75 < C_{ef} \leq 447.91$	$447.91 < C_{ef} \leq 566.82$	$566.82 < C_{ef} \leq 665.90$	$C_{ef} > 665.90$
$x_{i,25,3,1}$	1	2	3	4	5
<i>Oil</i>	$O_{ef} \leq 349.49$	$349.49 < O_{ef} \leq 387.65$	$387.65 < O_{ef} \leq 430.60$	$430.60 < O_{ef} \leq 653.10$	$O_{ef} > 653.10$
$x_{i,25,3,2}$	1	2	3	4	5
<i>Natural gas</i>	$NG_{ef} \leq 221.81$	$221.81 < NG_{ef} \leq 228.05$	$228.05 < NG_{ef} \leq 231.12$	$231.12 < NG_{ef} \leq 239.30$	$NG_{ef} > 239.30$
$x_{i,25,3,3}$	1	2	3	4	5
<i>EF</i>	$3 \leq EF < 5,4$	$5,4 \leq EF < 7,8$	$7,8 \leq EF < 10,2$	$10,2 \leq EF < 12,6$	$12,6 \leq EF \leq 15$
$x_{i,25,3}$	1	2	3	4	5
<b>Avoided CO<sub>2</sub> emissions</b>	$3 \leq CO_2 < 5,4$	$5,4 \leq CO_2 < 7,8$	$7,8 \leq CO_2 < 10,2$	$10,2 \leq CO_2 < 12,6$	$12,6 \leq CO_2 \leq 15$
<b>[-]</b>					
$x_{i,25}$	1	2	3	4	5

Table 5.42. Performance values  $x_{i,25}$  for avoided CO<sub>2</sub> emissions criterion for CHP

<b>Capacity factor</b>	grade from the Capacity criterion (see Table 5.20.)				
$x_{i,25,1}$	1	2	3	4	5
<b>Fossil fuel mix</b>					
[p.u.]					
<i>Coal share</i>	$C_{share} \leq 0.05$	$0.05 < C_{share} \leq 0.28$	$0.28 < C_{share} \leq 0.56$	$0.56 < C_{share} \leq 0.83$	$C_{share} > 0.83$
$x_{i,25,2,1}$	1	2	3	4	5
<i>Oil share</i>	$O_{share} \leq 0.01$	$0.01 < O_{share} \leq 0.05$	$0.05 < O_{share} \leq 0.11$	$0.11 < O_{share} \leq 0.14$	$O_{share} > 0.14$
$x_{i,25,2,2}$	1	2	3	4	5
<i>Natural gas share</i>	$NG_{share} > 0.89$	$0.64 < NG_{share} \leq 0.89$	$0.37 < NG_{share} \leq 0.64$	$0.2 < NG_{share} \leq 0.37$	$NG_{share} \leq 0.2$
$x_{i,25,2,3}$	1	2	3	4	5
$FF_{mix}$	$3 \leq FF_{mix} < 5,4$	$5,4 \leq FF_{mix} < 7,8$	$7,8 \leq FF_{mix} < 10,2$	$10,2 \leq FF_{mix} < 12,6$	$12,6 \leq FF_{mix} \leq 15$
$x_{i,25,2}$	1	2	3	4	5
<b>Emission factor</b>					
[gCO <sub>2</sub> /kWh]					
<i>Coal</i>	$C_{ef} \leq 630.29$	$630.29 < C_{ef} \leq 968.29$	$968.29 < C_{ef} \leq 1,047.96$	$1,047.96 < C_{ef} \leq 1,221.16$	$C_{ef} > 1,221.16$
$x_{i,25,3,1}$	1	2	3	4	5
<i>Oil</i>	$O_{ef} \leq 556.04$	$556.04 < O_{ef} \leq 644.67$	$644.67 < O_{ef} \leq 763.19$	$763.19 < O_{ef} \leq 867.55$	$O_{ef} > 867.55$
$x_{i,25,3,2}$	1	2	3	4	5
<i>Natural gas</i>	$NG_{ef} \leq 285.66$	$285.66 < NG_{ef} \leq 299.88$	$299.88 < NG_{ef} \leq 322.96$	$322.96 < NG_{ef} \leq 368.30$	$NG_{ef} > 368.30$
$x_{i,25,3,3}$	1	2	3	4	5
<i>EF</i>	$3 \leq EF < 5,4$	$5,4 \leq EF < 7,8$	$7,8 \leq EF < 10,2$	$10,2 \leq EF < 12,6$	$12,6 \leq EF \leq 15$
$x_{i,25,3}$	1	2	3	4	5
<b>Avoided CO<sub>2</sub> emissions</b>					
[-]	$3 \leq CO_2 < 5,4$	$5,4 \leq CO_2 < 7,8$	$7,8 \leq CO_2 < 10,2$	$10,2 \leq CO_2 < 12,6$	$12,6 \leq CO_2 \leq 15$
$x_{i,25}$	1	2	3	4	5

### 5.3.1.26. Protected areas

Protected areas may include national parks, archaeological sites, natural reserves, military zones, forest areas, biological areas, areas of animal protection, and ancestral lands of indigenous communities. Allowed activities in or near protected areas are defined generally by national laws or local restrictions for each country. Namely, in various countries high geothermal potential is mostly located in the volcanic landscapes (e.g. Indonesia, Central America, etc.) [247]–[250] which parts are very often designated protected areas (national parks, protected forests, etc.). When considering EGS, geothermal potential is not limited to solely volcanically active regions. Therefore, the protected areas could possibly remain intact. However, the enhancement techniques could be seen as activities of higher risk and impact and the corresponding ‘safety’ distance to protected areas may be larger. Based on previously mentioned, and to facilitate a widespread use of this criterion for different potential locations, a uniform linguistic evaluation is proposed [145]. Therefore, a buffer zone is defined, and it

represents a specific radius or distance from different protected areas within which the activities are not or are partially allowed (Figure 5.6). There are no restrictions regarding any activities outside this buffer zone, which is usually measured differently for individual protected areas. Qualitative evaluation of performance value  $x_{i,26}$  of alternative  $i$  for protected areas criterion is translated into a qualitative scale as shown in Table 5.43.

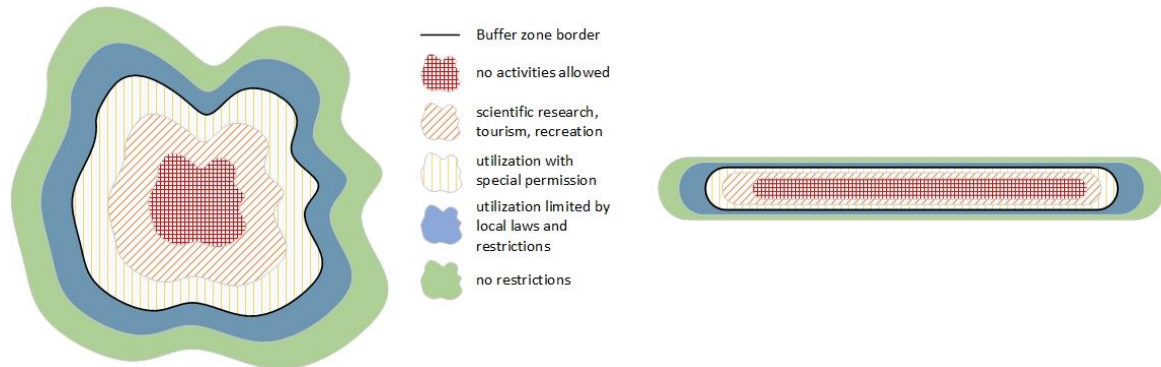

Figure 5.6. Buffer zone and the categorization used in Table 5.43. (published in: [145])

Table 5.43. Performance values  $x_{i,26}$  for protected areas criterion

Protected areas	$x_{i,26}$
Inside the buffer zone and no activities whatsoever are allowed.	1
Inside the buffer zone and only scientific research activities, tourism and recreation are allowed.	2
Inside the buffer zone but geothermal resources can be utilized and developed with special permission from authorities.	3
Outside the buffer zone, however the utilization is limited by local laws and restrictions.	4
Outside the buffer zone with no restrictions in place.	5

### 5.3.1.27. Potential seismicity

Development of an EGS system requires fluids pumping at high pressures to enhance permeability. However, this process is highly sensitive, because pumping too much water, or too fast, or in a critically stressed fault may create immoderate permeability which may, among other consequences, induce larger magnitude events, thereby increasing seismic hazard [251]. Increase in reinjection operations have been associated with increased induced seismicity, although the events are often of low energy ( $M_L < 2-3$ ) [144]. Additionally, aside from the induced seismicity, natural seismic activity near a producing geothermal system creates hazards for subsurface infrastructure, power plant surface infrastructure, and personnel. Therefore, in this method, both natural seismicity (i.e., natural seismic hazard) and induced seismicity (i.e., induced seismic hazard) are evaluated separately as sub-factors and then combined to present the evaluation of potential seismicity criterion.

Natural seismic hazard is evaluated based on evolution of additional three sub-factors which include: the peak ground acceleration (PGA), the ratio between maximum magnitude

occurred at or near the geothermal site ( $M_{max,occ}$ ) in the last 30 years and maximum possible magnitude predicted for that site ( $M_{max,pos}$ ); and the maximum possible magnitude predicted for a given site ( $M_{max,pos}$ ). Based on the approach in [252], to quantify the estimated local natural seismic hazard, which is based on an assessment for all of Europe that conforms to a single standard, the PGA in units of ‘g’ is used. The PGA value for a specific site describes the acceleration level on stiff soil that has a 10% probability of being exceeded in 50 years [145]. For the  $M_{max,occ}/M_{max,pos}$  ratio sub-criterion, the higher the ratio the better the grade because it is less unlikely that another high magnitude seismic event will appear during the lifetime of the power plant. For the maximum magnitude sub-factor, the higher the magnitude, the lower the grade since it means that the site is located in a highly seismic active area.

In this method, the assessment of potential seismicity criterion is slightly different for projects under development and developed project. Namely, the evaluation of natural seismic hazard is equal for both types of projects, but they differ in the evaluation of induced seismic hazard.

For projects under development the performance value  $x_{i,27,2}$  for induced seismic hazard is evaluated by calculating average of performance values of additional sub-factors. Those sub-factors are: estimated injected volume ( $m^3$ ); and qualitative sub-criterion ‘addressing the hazard’. The estimated fluid volume for the injection ( $V_{inj}$ ), when stimulating the reservoir, is crucial factor for the assessment of induced seismicity since the fluid volume is proportional to the magnitude of seismic events [253], [254]. The thresholds for performance value  $x_{i,27,2,1}$  for estimated injection volume sub-criterion are based on the database of real EGS sites where the seismic activity was also measured. Second sub-factor ‘addressing the hazard’ is related to the measures, protocols, surveys, monitoring, etc., that need to be or could be conducted in order to facilitate profitable deployment of EGS project by taking into account potential seismic events [255]. Higher performance value  $x_{i,27,2,2}$  for ‘addressing the hazard’ sub-factor is assigned to the projects with the most conducted actions and vice versa.

For developed projects the performance value  $x_{i,27,2}$  for induced seismic hazard is evaluated by calculating average of performance values of additional sub-factors. The sub-factors for such projects are: the number of seismic events that occurred during stimulation evaluated with the performance value  $x_{i,27,2,1}$ ; and number of seismic events that occurred during circulation evaluated with the performance value  $x_{i,27,2,2}$ . Both sub-factors are expressed qualitatively, however, the magnitude of occurred seismic events is the focused

parameter. In the [256], the authors found the correlation between the large-scale fluid injection and the seismic activity, and stated that the main cause of seismic induction is the increase in the fluid pressure. For the second sub-factor, the conducted circulation tests in [257] proved the existence of the correlation between the circulation of the fluid and seismicity, where the increased circulation flow caused the seismic events with greater magnitude.

Total performance value  $x_{i,27}$  for potential seismicity criterion denoted as  $ps$ , is obtained according to the Equation (5.26) as the weighted sum of performance values for natural seismic hazard,  $x_{i,27,1}$ , and induced seismic hazard,  $x_{i,27,2}$ , sub-criteria (Table 5.44). Namely, to emphasize the induced seismicity related to the EGS projects the average grade for induced seismic hazard sub-criterion is multiplied by 1.5. Thresholds for sub-factors ( $x_{i,27,1,1}$ ,  $x_{i,27,1,2}$ ,  $x_{i,27,1,3}$ ) of the natural seismic hazard are defined in Table 5.45 and Table 5.46 and are used to evaluate and obtain average ( $AV_n$ ) for both developed project and projects under development. To obtain the average for induced seismic hazard sub-criterion, grades for corresponding sub-factors ( $x_{i,27,2,1}$ ,  $x_{i,27,2,2}$ ) should be taken, and either  $AV_{i,d}$  (for developed projects) or  $AV_{i,ud}$  (for projects under development) should be calculated.

$$x_{i,27} = w_{i,27,1} \cdot x_{i,27,1} + w_{i,27,2} \cdot x_{i,27,2} \quad (5.26)$$

Table 5.44. Weight of each sub-criterion  $w_{i,27,z}$  in the potential seismicity criterion

Sub-criterion	Weight $w_{i,27,z}$
Natural seismic hazard	1
Induced seismic hazard	1.5

Table 5.45. Performance values for potential seismicity criterion for developed (running) projects (upscaling or extension) and projects under development

	PGA [%g]	$PGA \geq 32$	$24 \leq PGA < 32$	$16 \leq PGA < 24$	$8 \leq PGA < 16$	$PGA < 8$
Natural seismic hazard (developed and under development)	$x_{i,27,1,1}$	1	2	3	4	5
	$\frac{M_{max,occ}}{M_{max,pos}}$	$\frac{M_{max,occ}}{M_{max,pos}} < 0.2$	$0.2 \leq \frac{M_{max,occ}}{M_{max,pos}}$	$0.4 \leq \frac{M_{max,occ}}{M_{max,pos}}$	$0.6 \leq \frac{M_{max,occ}}{M_{max,pos}}$	$\frac{M_{max,occ}}{M_{max,pos}} \geq 0.8$
			$< 0.4$	$< 0.6$	$< 0.8$	
	$x_{i,27,1,2}$	1	2	3	4	5
	$M_{max,pos}$ [Richter]	$M_{max,pos} > 7$	$6.5 < M_{max,pos} \leq 7$	$6 < M_{max,pos} \leq 6.5$	$5.5 < M_{max,pos} \leq 6$	$M_{max,pos} \leq 5.5$
	$x_{i,27,1,3}$	1	2	3	4	5
	average	$AV_n \leq 1$	$1 < AV_n \leq 2$	$2 < AV_n \leq 3$	$3 < AV_n \leq 4$	$4 < AV_n \leq 5$
	$x_{i,27,1}$	1	2	3	4	5

Table 5.46. Performance values for potential seismicity criterion for developed (running) projects (upscaling or extension) and projects under development (*continued*)

						$x_{i,27,2,1}$
Induced seismic hazard (for developed projects)	<b>Seismic event occurred during stimulation</b>	<i>many events with <math>M_L &gt; 3</math></i>				1
		<i>couple events with <math>3 \leq M_L &lt; 4</math></i>				2
		<i>many events with <math>2 \leq M_L &lt; 3</math></i>				3
		<i>some events with <math>1 \leq M_L &lt; 2</math></i>				4
		<i>no events with <math>M_L &lt; 1</math></i>				5
						$x_{i,27,2,2}$
Induced seismic hazard (for projects under development)	<b>Seismic event occurred during circulation</b>	<i>many events with <math>M_L &gt; 3</math></i>				1
		<i>couple events with <math>3 \leq M_L &lt; 4</math></i>				2
		<i>many events with <math>2 \leq M_L &lt; 3</math></i>				3
		<i>some events with <math>1 \leq M_L &lt; 2</math></i>				4
		<i>no events with <math>M_L &lt; 1</math></i>				5
	<b>average</b>	$AV_{i,d} \leq 1$	$1 < AV_{i,d} \leq 2$	$2 < AV_{i,d} \leq 3$	$3 < AV_{i,d} \leq 4$	$4 < AV_{i,d} \leq 5$
	$x_{i,27,2}$	1	2	3	4	5
	<b>Estimated injection volume [m<sup>3</sup>]</b>	$V_{inj} > 10^8$	$10^8 \leq V_{inj} < 10^6$	$10^6 \leq V_{inj} < 10^4$	$10^2 \leq V_{inj} < 10^4$	$V_{inj} < 10^2$
	$x_{i,27,2,1}$	1	2	3	4	5
						$x_{i,27,2,2}$
Induced seismic hazard (for projects under development)	<b>Addressing the hazard [-]</b>	No preliminary screening, no implemented outreach to the local community, no established local seismic monitoring, no quantified hazard from natural seismic events, no quantified hazard from induced seismic events				1
		Preliminary screening, no implemented outreach to the local community, no established local seismic monitoring, no quantified hazard from natural seismic events, no quantified hazard from induced seismic events				2
		Preliminary screening, implemented outreach to the local community, no established local seismic monitoring, no quantified hazard from natural seismic events, no quantified hazard from induced seismic events				3
		Preliminary screening done, implemented outreach to the local community, established local seismic monitoring, no quantified hazard from natural seismic events or from induced seismic events				4
		Preliminary screening done, implemented outreach to the local community, established local seismic monitoring, quantified hazard from natural seismic events, quantified hazard from induced seismic events				5
	<b>average</b>	$AV_{i,ud} \leq 1$	$1 < AV_{i,ud} \leq 2$	$2 < AV_{i,ud} \leq 3$	$3 < AV_{i,ud} \leq 4$	$4 < AV_{i,ud} \leq 5$
	$x_{i,27,2}$	1	2	3	4	5
	<b>Potential seismicity [-]</b>	$ps \leq 2.5$	$2.5 < ps \leq 5$	$5 < ps \leq 7.5$	$7.5 < ps \leq 10$	$10 < ps \leq 12.5$
	$x_{i,27}$	1	2	3	4	5

### 5.3.1.28. Conflict with other subsurface uses

Subsurface resources include gas, oil, groundwater, saline aquifer minerals, and heat for geothermal use [258]. Hence, it is crucial to understand the potential range of the available

resources in the targeted area before the allocation of subsurface resources. This entails considering their sequential development and assessing their interdependencies when utilized concurrently [145]. The sustainable management of the subsurface is specific from region to region, country to country, etc. Therefore, a qualitative linguistic evaluation of the potential conflict with other subsurface uses is proposed in this method, to be able to generally cover the likelihood of concurrent and sequential uses of subsurface resources. A matrix aimed at facilitating the evaluation of the conflict with other subsurface uses was built with two axes. This is a similar approach as used for visual impact assessment in [30]. The horizontal axis represents the distance between existing/potential subsurface uses and vertical axis represents number of existing/potential subsurface uses. After this conflict is evaluated through a qualitative judgement, this qualitative evaluation is translated into a qualitative scale (Figure 5.7). Based on the data from [258], the thresholds for the performance value  $x_{i,28}$  of alternative  $i$  for conflict with other uses criterion are later shown in Table 5.47.

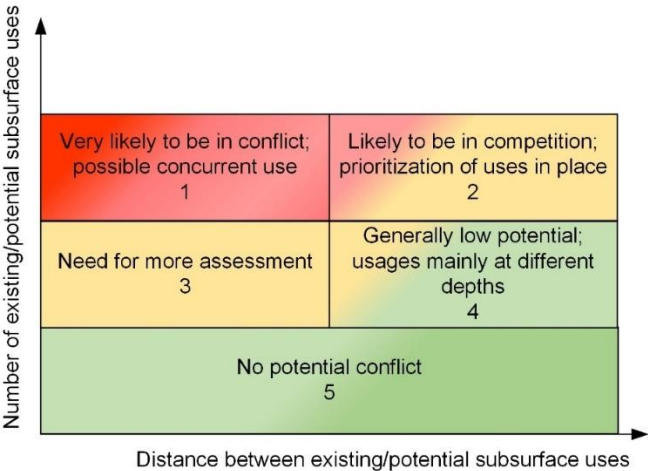

Figure 5.7. Evaluation matrix for conflict with other subsurface uses (published in: [145])

Table 5.47. Performance values  $x_{i,28}$  for conflict with other subsurface uses criterion

<b>Conflict with other subsurface uses</b>	$x_{i,28}$
Uses are very likely to be compatible. Moreover, the uses are concurrent and therefore the geothermal development might be characterized as low priority use.	1
Uses are likely to be in competition. Certain exploitation prioritization is applied.	2
There is a need for more assessment of potential conflict.	3
Generally low potential of conflict: usages are mainly at different depths.	4
No potential conflict.	5

### 5.3.2. Case study - results

The case study presented in this Section was formed as part of the study published in [145].

Formed case study included two different sites and both sites are currently used for heat production for industrial purposes and electricity generation, respectively. The geological context of both geothermal sites is similar; however, the characteristics of site terrains differ. These set of input parameters represent realistic geothermal sites. Furthermore, since the sites are located in similar geological setting, the case study brings more emphasis on the technology and economy/finance related criteria.

The case study was created to verify the proposed method for standardized evaluation of defined influencing criteria. The defined criteria and proposed method were used to estimate and compare the first scenario of heat production and second scenario of electricity generation. For a successful estimation and comparison, the values of each criterion for each site were entered, assessed, or calculated and for each value a corresponding grade was given according to the thresholds defined in Section 5.3.1. The input parameters exemplify the geothermal projects that could be found in reality. The main input parameters related to geological setting and power plant facility locations for both sites are shown in Table 5.48. Final evaluation of the chosen sites was calculated as average of all twenty-eight criteria creating thereby a solution of a decision-making problem that considers all influencing criteria equally important. The higher final grade represents the geothermal site with generally better performance regarding the geological settings, technology parameters, environmental and societal factors, and economic aspects and vice versa.

In the conducted analysis producer-injector doublet extraction technology was examined. Financial parameters used in the financial analysis are shown in Table 5.49. The same parameters are used for both production sites. The calculations of main techno-economic-environmental-societal parameters have been done by the means of the separate functional modules that have later been incorporated in a comprehensive evaluation model presented in Chapter 6. Main base case output parameters are presented in Table 5.50 for both geothermal sites and both production scenarios.



Table 5.48. Main input parameters for two selected geothermal sites

Parameter	Unit	Site 1	Site 2	
Permeability	matrix	$m^2$	$4.49 \cdot 10^{-16}$	$6.10 \cdot 10^{-16}$
	fracture	$m^2$	$5.52 \cdot 10^{-15}$	$5.52 \cdot 10^{-15}$
Porosity	matrix	p.u.	0.03	0.04
	fracture	p.u.	0.1	0.09
Reservoir type	-	stimulated	stimulated	
Reservoir volume	$km^3$	1	1	
Reservoir temperature	$^{\circ}C$	200	177	
Number of production wells	No.	1	1	
Number of injection wells	No.	2	1	
Production well depth (TVD)	m	4750	2708	
Production well direction	-	deviated (directional)	deviated (directional)	
Bottom-hole diameter	cm	21.59	21.59	
Wellhead temperature	$^{\circ}C$	148	168	
Injection temperature	$^{\circ}C$	70	85	
Flow rate	$m^3/s$	0.03	0.0875	
Fluid density	$kg/m^3$	990	970	
Specific heat capacity	$J/kg^{\circ}C$	3810	3820	
Corrosion and scaling hazard	-	present but managed	present but managed	
Distance to the power grid	km	0.4	1	
Distance to the heating network	km	0.3	15.3	
Project site area	-	rural	rural	
Project site terrain	-	hilly	flat	

Table 5.49. Financial parameters used in the case study

Parameter	Unit	Value
Effective tax rate	%	30
Inflation rate	%	2
Discount rate	%	5
Lifetime of the project	years	30

Table 5.50. Main output parameters - base case

Parameter	Unit	Site 1		Site 2	
		Scenario Heat	Scenario Electricity	Scenario Heat	Scenario Electricity
Installed capacity	MW	2.6	1.4	23.5	5.4
Produced energy (lifetime)	GWh	345.77	236.51	5,207.68	927.69
Avoided CO <sub>2</sub> emissions (lifetime)	tonnes CO <sub>2</sub> .eq	82,434	141,436	1,241,542	554,778
NPV	€	-949,678	-137,776	32,796,547	11,559,767
LCOE/LCOH	€/MWh	53.31	47.40	5.70	17.52

### 5.3.2.1. Scenario Heat

This scenario represents the heat production for Site 1 and Site 2 for greenhouse heating and industrial usage, respectively. The results of applying the defined set of criteria on two selected sites are shown in Table 5.51. Some of the data is taken as input and graded according to the thresholds, other data is firstly calculated by means of corresponding input parameters, and then graded according to the defined thresholds.

Table 5.51. Grading of each criterion of selected geothermal sites for 'Scenario Heat'

Parameter		Performance value	Site 1	Site 2
Geological setting	Permeability	$x_{i,1}$	3	3
	Porosity	$x_{i,2}$	3	3
	Reservoir type	$x_{i,3}$	3	3
	Reservoir volume	$x_{i,4}$	4	4
	Reservoir temperature	$x_{i,5}$	5	5
	Reservoir depth	$x_{i,6}$	3	4
	Fluid specific heat capacity	$x_{i,7}$	3	3
Technology	Capacity factor	$x_{i,8}$	5	5
	Deployment duration	$x_{i,9}$	5	5
	Proximity to the grid	$x_{i,10}$	5	4
	Global efficiency	$x_{i,11}$	5	5
	Wellhead temperature	$x_{i,12}$	1	5
	Flow rate	$x_{i,13}$	4	4
	Injection temperature	$x_{i,14}$	5	4
Economy/finance	LCOE/LCOH	$x_{i,15}$	3	5
	NPV (EAA)	$x_{i,16}$	1	5
	Capital cost	$x_{i,17}$	4	5
	O&M cost	$x_{i,18}$	2	4
	Discounted payback period	$x_{i,19}$	1	5
	Support schemes	$x_{i,20}$	2	2
Society	Job creation	$x_{i,21}$	4	3
	Social acceptability	$x_{i,22}$	4	4
Environment	Land use	$x_{i,23}$	5	5
	Noise	$x_{i,24}$	5	5
	Avoided CO <sub>2</sub> emissions	$x_{i,25}$	4	4
	Protected area	$x_{i,26}$	5	5
	Potential seismicity	$x_{i,27}$	4	4
	Conflict with other subsurface uses	$x_{i,28}$	5	5
<b>FINAL</b>			<b>3.6786</b>	<b>4.2143</b>

### 5.3.2.2. Scenario Electricity

This scenario represents electricity generation. The results of applying the defined set of criteria on two selected sites are shown Table 5.52. As in the scenario heat, some of the data is taken as input and graded according to the thresholds, other data is firstly calculated by

means of corresponding input parameters, and then graded according to the defined thresholds.

Table 5.52. Grading of each criterion of selected geothermal sites for electricity generation scenario

Parameter		Performance value	Site 1	Site 2
Geological setting	Permeability	$x_{i,1}$	3	3
	Porosity	$x_{i,2}$	3	3
	Reservoir type	$x_{i,3}$	3	3
	Reservoir volume	$x_{i,4}$	4	4
	Reservoir temperature	$x_{i,5}$	5	5
	Reservoir depth	$x_{i,6}$	3	4
	Fluid specific heat capacity	$x_{i,7}$	3	3
Technology	Capacity factor	$x_{i,8}$	3	2
	Deployment duration	$x_{i,9}$	5	5
	Proximity to the grid	$x_{i,10}$	5	4
	Global efficiency	$x_{i,11}$	1	1
	Wellhead temperature	$x_{i,12}$	1	5
	Flow rate	$x_{i,13}$	4	4
	Injection temperature	$x_{i,14}$	5	4
Economy/finance	LCOE/LCOH	$x_{i,15}$	2	5
	NPV (EAA)	$x_{i,16}$	1	5
	Capital cost	$x_{i,17}$	5	5
	O&M cost	$x_{i,18}$	3	3
	Discounted payback period	$x_{i,19}$	5	5
Society	Support schemes	$x_{i,20}$	4	4
	Job creation	$x_{i,21}$	3	3
	Social acceptability	$x_{i,22}$	4	4
Environment	Land use	$x_{i,23}$	5	5
	Noise	$x_{i,24}$	5	5
	Avoided CO <sub>2</sub> emissions	$x_{i,25}$	3	3
	Protected area	$x_{i,26}$	5	5
	Potential seismicity	$x_{i,27}$	4	4
	Conflict with other subsurface uses	$x_{i,28}$	5	5
FINAL			<b>3.6429</b>	<b>3.9643</b>

### 5.3.2.3. Discussion

Two scenarios for two different geothermal sites were observed and used to compare the results obtained with the proposed method. The two observed scenarios include only electricity generation and only heat production. Since exploration, drilling, and stimulation were already conducted at both geothermal sites, the scenarios were observed beginning with construction phase. Furthermore, since the observed sites are located in similar geological setting, the results mostly show how the technology and economy related criteria influence

the final grade. Additionally, the evaluation of the project greatly depends on the chosen weights assigned to the different criteria. In this case study, it is considered that each criterion has equal relative importance in decision making process, therefore the weights associated with each criterion are considered identical and are valued with unitary weight. However, it is important to accentuate that the weights assigned to each criterion can vary significantly depending on the DM's standpoint. Therefore, the results of the final evaluation of the geothermal energy project will vary according to DM's preferences and interests which are reflected in assigned weights.

From the results it is visible that several factors can impose significant constraints on development of an EGS project. Those factors among other include wellhead temperature, which is highly related to the reservoir depth, which also has a great impact on economics of the project. Additionally, especially when considering the 'Scenario Electricity' of only electricity generation, larger difference between production (wellhead) temperature and injection temperature, as much as higher flow rate lead to the higher potentially installed capacity of the power plant, and thereby the larger amount of generated electricity. Therefore, the Site 2 is evaluated with higher final grade (3.9643) than the Site 1 (3.6429) for the 'Scenario Electricity' (Table 5.52). From those results it can be concluded that, in most cases, higher wellhead temperatures are more suitable and economically viable for electricity generation. However, specific end-use demand may determine the final end-use application regardless of the results obtained by applying this methodology. Additionally, in charts depicted in Figure 5.8 and Figure 5.9, it can also be seen that the economic parameters (marked pink) are evaluated as very important criteria, which only highlights and confirms the fact that the geothermal projects, and EGS projects above everything, are highly capital intensive. Therefore, the feasibility of such projects, especially at the beginning of the lifetime highly depends on the support schemes that can improve economic feasibility of specific project. As it can be seen on charts, Site 2 obtained much better grades for two main economic parameters, NPV and LCOE, respectively, which in the end led to the higher final grade for Site 2. However, even though the Site 2 showed much higher grades for economic parameters, there is no significant difference between final grades (Table 5.52) which can be explained by the fact that each criterion was assigned with equal relative importance in decision-making.

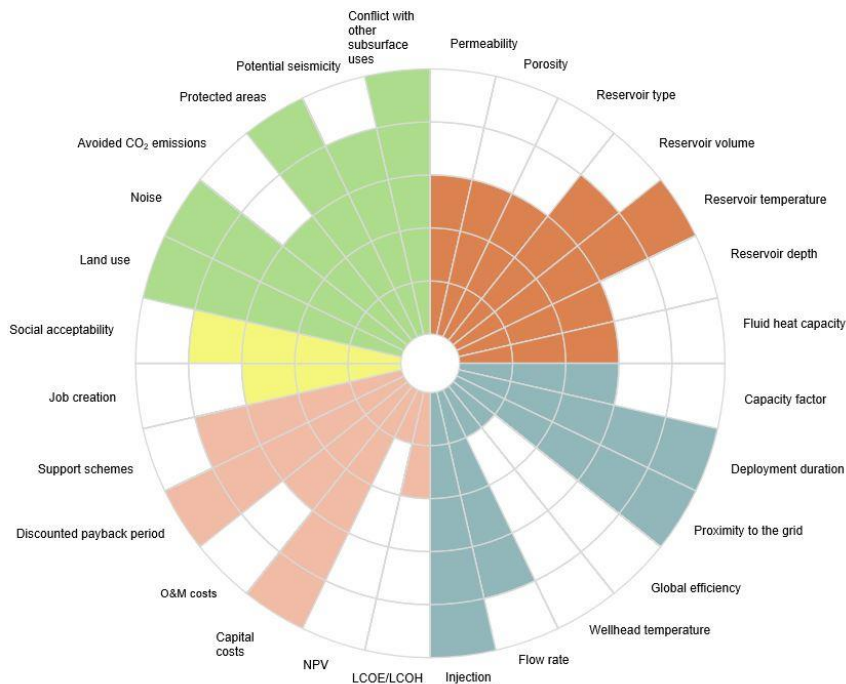

Figure 5.8. Criteria grade diagram for 'Scenario Electricity' - Site 1

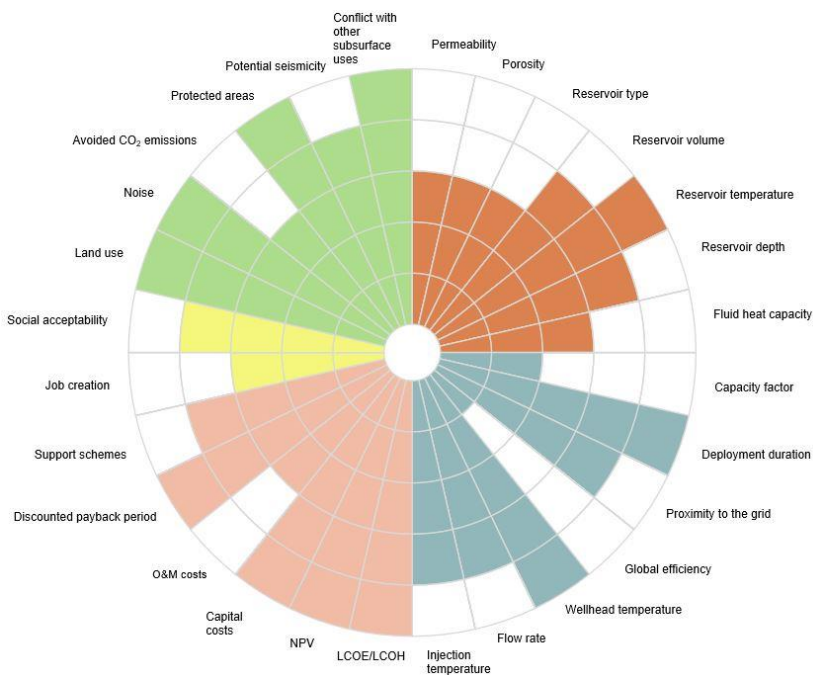

Figure 5.9. Criteria grade diagram for 'Scenario Electricity' - Site 2

Regarding the ‘Scenario Heat’ the difference between final grades for Site 1 and Site 2 is somewhat larger than for the ‘Scenario Electricity’. Namely, for direct heat usage at Site 1 the investment cost is such that the discounted payback period is not achieved till the end of the project lifetime period and consequently the NPV is negative. Furthermore, considering that subsidies in this case study are available for a short period of time, i.e., only for the first three years of heat production, the grades for economic group of criteria (marked pink in Figure 5.10.) are very low, which leads to significantly lower final grade for Site 1 (3.6787) in

comparison to Site 2 (4.2143). Site 2 has more favourable grades for the economy group of criteria since the installed capacity and consequently produced heat are significantly higher than in the case of Site 1 (Table 5.51). Additionally, the technology related criteria have more uniform higher scores for Site 2 than for Site 1.

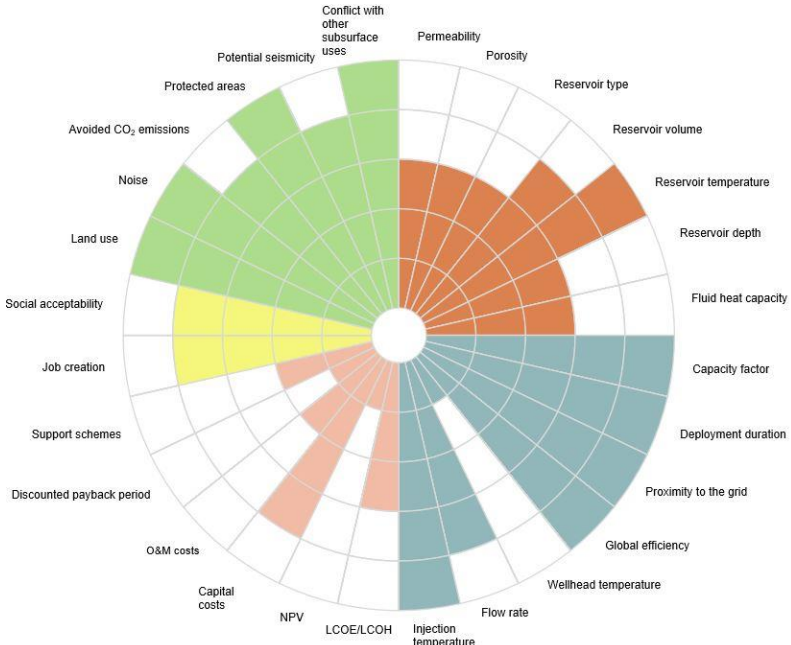

Figure 5.10. Criteria grade diagram for 'Scenario Heat' - Site 1

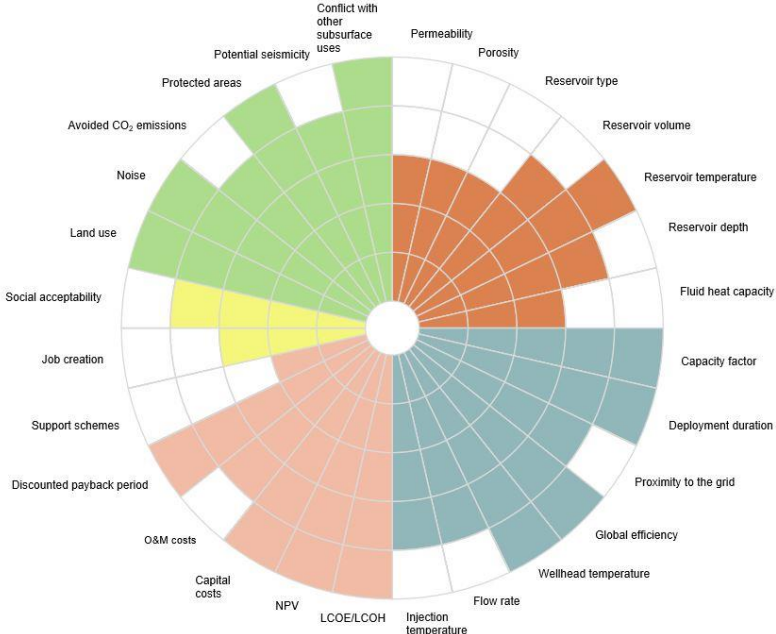

Figure 5.11. Criteria grade diagram for 'Scenario Heat' - Site 2

Societal and environmental impacts of selected EGS sites can be characterized as favourable for both scenarios. That is visible also from charts in Figure 5.8, Figure 5.9, Figure 5.10, and Figure 5.11. Societal impact is rather positive since the evaluated projects are small- to medium-size projects and represent therefore higher benefits than detriments for local

community. Namely, for both sites, and especially for Site 1 for ‘Scenario Heat’, the equilibrium between energy facility size and local impact and gains in terms of FT and C&M jobs is established. Regarding the environmental impact, the installed capacity of energy facility for both sites and both scenarios impose low land-use intensity. Additionally, in case of electricity generation, the air-cooled condensers are modelled and used which consequently decreases the additional surface water needs. The potential seismicity is for both sites assessed as very satisfactory, which generally leads to higher social acceptability of such projects. Namely, potential seismic events that occur during simulation and/or operational phase can lead to the viable project being abandoned and shut down.

Besides the geological factors, that have significant impact on the final grade of a specific geothermal site and project, the major role in distinguishing the final grade for the performance of each scenario had the economic parameters such as NPV, LCOE, and discounted payback period. Namely, those economic indicators are very often used when assessing the economic feasibility and profitability of a project. The cash flows throughout the project lifetime for the ‘Scenario Electricity’ are shown in Figure 5.12. and Figure 5.13. For ‘Scenario Electricity’ the discounted payback periods for Site 1 and Site 2, are 10.3 years and 8.2 years respectively. Therefore, this criterion is for both sites assessed with the highest grade because the discounted payback periods are less than half of the project lifetime. The NPV for the Site 1 resulted in negative value of -137,776 €, while the NPV for Site 2 was 11,559,767 €. Such values can be attributed mostly to the achieved revenues for both sites. Namely, the specific capital cost for Site 2 was calculated to be 3,494.16 €/kW, which is lower than that calculated for the Site 1, namely 4,709.03 €/kW. Additionally, the total operational and maintenance costs were estimated for both sites at 0.0379 €/kWh, as well as the power plant operating cost at 0.0290 €/kWh. However, the installed capacity at Site 2 is more than twice higher than for Site 1 (Table 5.50), which consequently yields more electricity generated and revenues obtained for sold energy. It can be concluded that the subsidy and its duration of 15 years also contributed to achieving the payback of the investment in less than a half of the project’s lifetime for both sites. The frequency replacement of the production pump is also shown in Figure 5.12 and Figure 5.13, which is projected in the negative peaks of total cash outflows each 6 years. Regarding the LCOE, the much higher amount of generated electricity at Site 2 has contributed to a lower LCOE value of 17.52 €/MWh in comparison to LCOE value of 47.40 €/MWh at the Site 1.

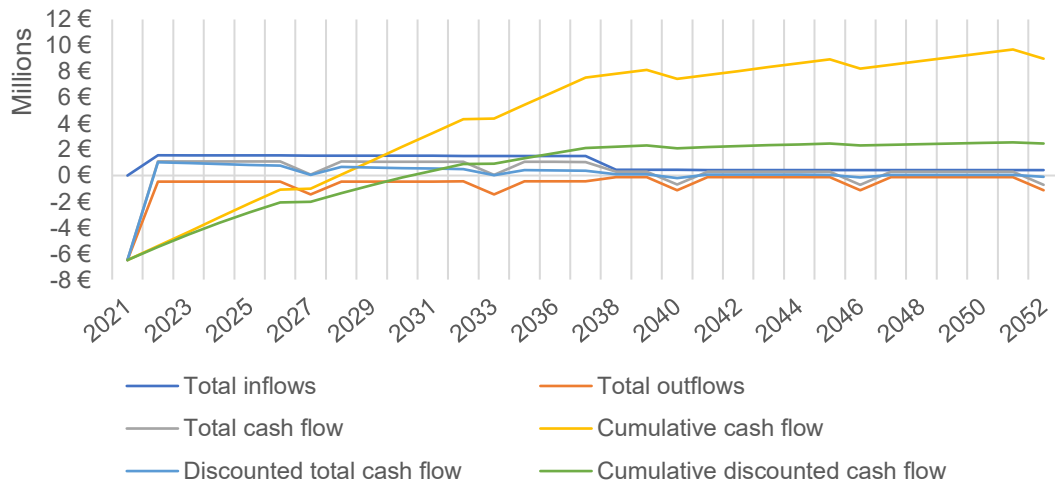

Figure 5.12. Cash flow for 'Scenario Electricity' - Site 1 (author's own work published in: [145])

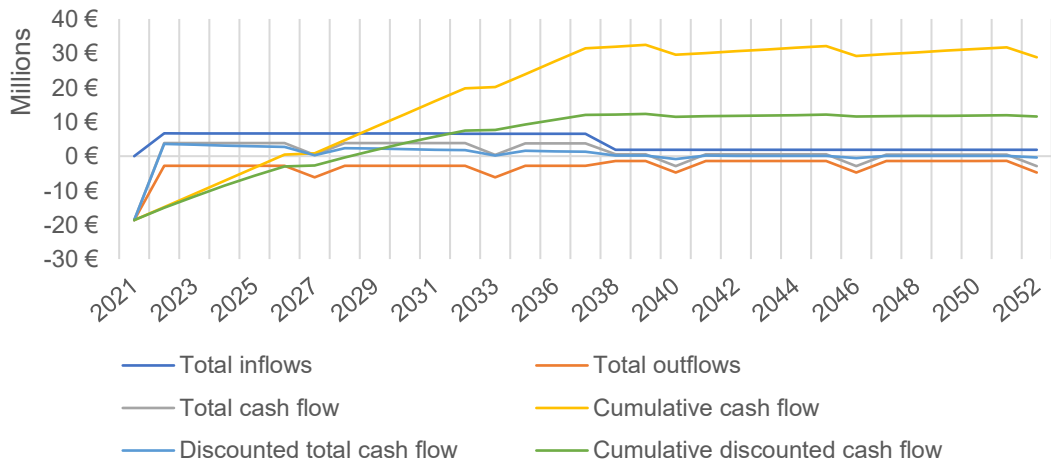

Figure 5.13. Cash flow for 'Scenario Electricity' - Site 2 (author's own work published in: [145])

The cash flows throughout the project lifetime for the 'Scenario Heat' are shown in Figure 5.14 and Figure 5.15. The discounted payback period for Site 1 in this scenario is longer than the lifetime of the project, which is very unfavourable, and therefore this criterion is graded with value 1 (Figure 5.14.). In contrast, the payback period for Site 2 is 3.1 years. The net present value was calculated at -949,679 € for the Site 1, and for Site 2 at 32,796,547 €. The high NPV value for Site 2 is directly associated to the fact that the installed capacity for Site 2 is almost ten times larger in comparison to Site 1. Consequently, higher volumes of heat are produced and sold, achieving thereby higher revenues which enables positive cash flows throughout the whole lifetime of the project after the construction of the energy facility (Figure 5.15). Total cash outflows consist of capital investment, operating and maintenance costs, and frequent production pump replacement each 6 years which can be seen as the negative peaks in total cash outflows curve. The operational and maintenance costs differentiated for the two sites, resulting in 0.0125 €/kWh for Site 1 and 0.0056 €/kWh for



Site 2. The facility operating costs were lower for the Site 2 (0.0023 €/kWh) in comparison to the Site 1 (0.0035 €/kWh). Regarding the LCOH, lower value was obtained for the Site 2 (5.70 €/MWh) in comparison to the Site 1 (53.31 €/MWh) where the installed capacity, i.e., the produced heat influenced the LCOH value the most because the specific capital costs for Site 1 and for Site 2 differ just slightly, 1,128,15 €/kW and 1,085.38 €/kW, respectively.

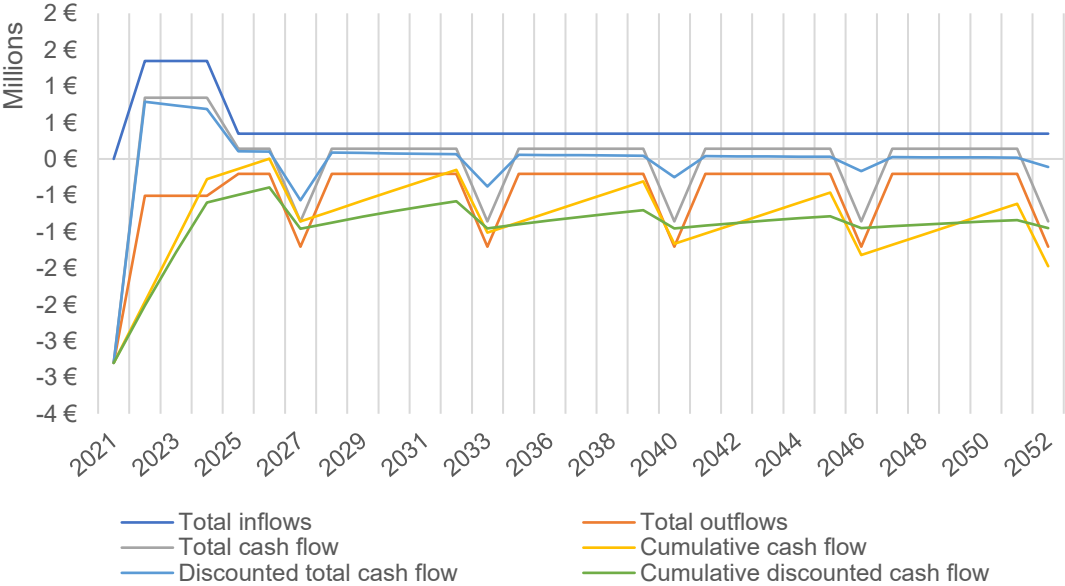

Figure 5.14. Cahs flow for 'Scenario Heat' - Site 1 (author’s own work published in: [145])

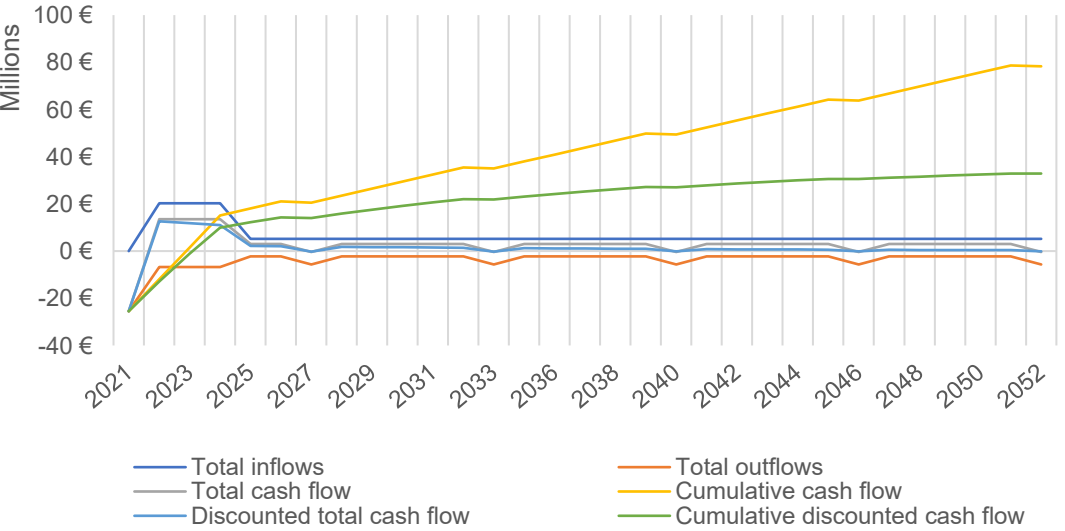

Figure 5.15. Cash flow for 'Scenario Heat' - Site 2 (author’s own work published in: [145])

5.3.2.4. Sensitivity analysis of LCOE for ‘Scenario Electricity’

Sensitivity analysis was conducted for both sites with the focus on independent variables (CAPEX, OPEX, discount rate, lifetime duration, subsidies, energy selling price, etc.) effect on the dependent variable, i.e., LCOE. This sensitivity analysis enables to distinct between

high-leverage variables, whose variations have significant impact on the dependent variables and low-leverage variables, whose variations have minimal impact.

High upfront costs present the biggest drawback considering investing in geothermal energy project and especially EGS projects. High upfront costs are mainly related with the drilling of the wells where for a conventional hydrothermal project drilling accounts for 30-40% of a project's CAPEX, whereas for EGS projects, where stimulation needs to be taken into account, the value is between 50-65% [233], reaching in some cases even 75%. High CAPEX elevates barriers for EGS technology to enter the market and stalls the development of this industry, whereas as many pilot sites as possible are crucial for validating and refining the concept. However, it should also be emphasized that the costs are highly site specific and dependable on the stage of the project development or extension. The CAPEX and OPEX values (Table 5.53) are for the purpose of this sensitivity analysis estimated based on the real data collected from the literature or by directly contacting some existing pilot EGS power plants. The CAPEX includes costs for all the phases of a geothermal project. Namely, it is foreseen that one doublet is drilled, and the stimulation of the reservoir is conducted. For 'Scenario Electricity' the ORC power plant is modelled. The CAPEX is represented with specific investment costs in €/kW for both sites and OPEX is for each site calculated as the sum of well field maintenance costs, power plant maintenance costs, labour costs and power plant operational costs.

Table 5.53. Economic parameters for base case for both sites for 'Scenario Electricity'

<b>Parameter</b>	<b>Unit</b>	<i>Site 1</i>	<i>Site 2</i>
CAPEX	€/kW	4,709.03	3,494.17
OPEX	€/kWh	0.0379	0.0379
Subsidies	€/kWh	0.17	0.17
Duration of subsidies	years	15	15
Energy selling price	€/MWh	70	70
Effective tax rate	%	30	30
Inflation rate	%	2	2
Discount rate	%	5	5
Lifetime of the project	years	31	31

The values of a base case shown in Table 5.22 were changed +/- 20% and the obtained input data for the sensitivity analysis for Site 1 and Site 2 are shown in Table 5.54 and Table 5.55, respectively.

Table 5.54. The change of main economic input parameters for Site 1

Parameter	Unit	Decrease	Base	Increase
CAPEX	€/kW	3,767.36	4,709.03	5,650.84
OPEX	€/kWh	0.0303	0.0379	0.0455
Subsidies	€/kWh	0.136	0.17	0.204
Duration of subsidies	years	12	15	18
Energy selling price	€/MWh	56	70	84
Effective tax rate	%	24	30	36
Inflation rate	%	1.6	2	2.4
Discount rate	%	4	5	6
Lifetime of the project	years	24	30	36

Table 5.55. The change of main economic input parameters for Site 2

Parameter	Unit	Decrease	Base	Increase
CAPEX	€/kW	2,795.34	3,494.17	4,192.99
OPEX	€/kWh	0.0303	0.0379	0.0455
Subsidies	€/kWh	0.136	0.17	0.204
Duration of subsidies	years	12	15	18
Energy selling price	€/MWh	56	70	84
Effective tax rate	%	24	30	36
Inflation rate	%	1.4	2	2.6
Discount rate	%	4	5	6
Lifetime of the project	years	24	30	36

Figure 5.16 represents sensitivity of calculated LCOE to variations in selected parameters for Site 1. The central value of the plot is the calculated LCOE for the base case scenario and is equal to 47.40 €/MWh. Figure 5.17. represents sensitivity of calculated LCOE to variations in selected parameters for Site 2. The central value, i.e., base case LCOE is equal to 17.52 €/MWh. The LCOE is most sensitive to the variation in the subsidies amount, followed by the variations in CAPEX and OPEX.

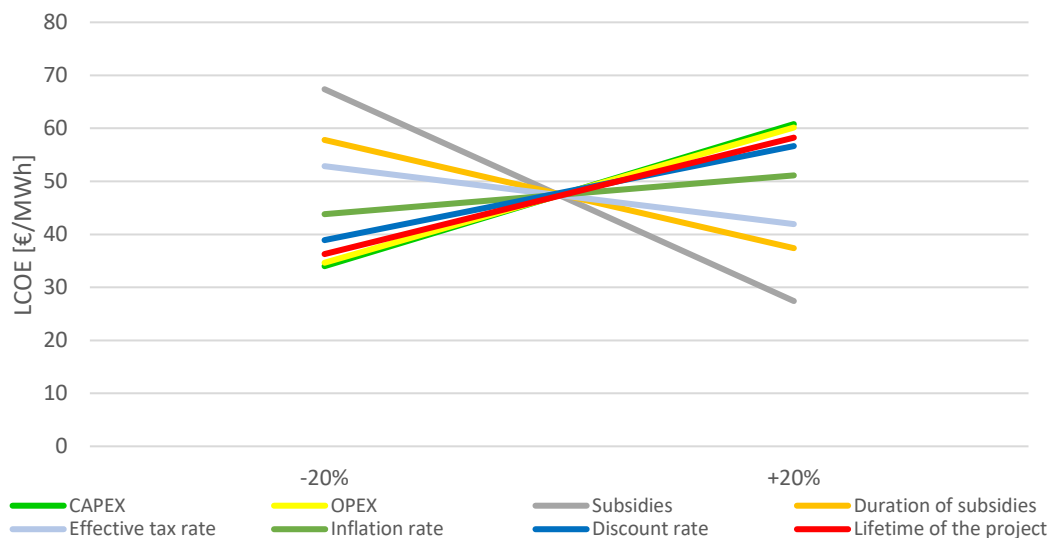

Figure 5.16. Sensitivity analysis plot showing changes of LCOE related to the changes (+/- 20%) of main economic input parameters – Site 1 (author's own work published in: [145])

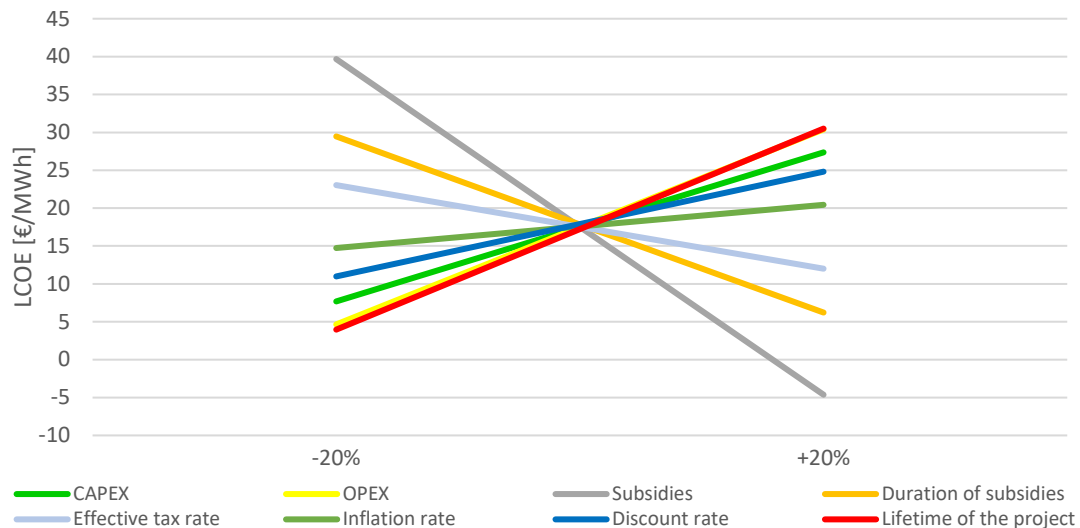

Figure 5.17. Sensitivity analysis plot showing changes of LCOE related to the changes (+/- 20%) of main economic input parameters – Site 2 (author's own work published in:[145])

#### 5.4. INTEGRATED MCDM METHODOLOGY

As introduced in Chapter 4, Section 4.1 the MCDM can be divided into two groups MODM and MADM. Methodology proposed in this thesis belongs to the MADM group. Namely, MADM is a process of making a preference decision by evaluating a finite number of pre-specified alternatives under multiple and usually conflicting criteria which are both quantitative and qualitative. Therefore, considering that the proposed methodology is used for evaluating geothermal energy projects, with the emphasis on EGS projects and comparing different utilization options at the same geothermal site or comparing different geothermal sites, it is assumed that finite number of alternatives (options) are considered. Assessment of alternatives with respect to each criterion and relative importance of criteria (or some information in that regard) are main inputs of MADM methods, while the output is evaluation of alternatives based on the criteria. MADM methods have the power of identifying the structure of complex decision-making problems and elucidating decision makers' preferences. These methods are also understandable and reliable for the decision makers, which was very important feature when developing the proposed methodology. Namely, this approach will contribute to more efficient EGS projects understanding and development, as well as increase of public awareness of such projects. Consequently, this could enable greater penetration of the EGS into the market boosting thereby the latest energy transition trends in terms of reaching decarbonisation targets and net-zero emissions by mid-century. From all the features mentioned above, the MADM methods are being used more and more by different analysts

and decision-makers. The main MADM process can be summarized as shown in Table 5.56. This process was applied in this thesis.

Table 5.56. Main steps in MADM (summarized according to: [104])

Stage	Step	Description
Problems' structure statement	Precise problem definition	Identifying the problem, studying system boundaries, presumptions, and stakeholders
	Identifying alternatives' requirements	Identifying minimum requirements that are expected from alternatives
	Setting goal(s)	Identifying conditions that are desired to be achieved
	Identifying alternatives	Identifying options that are not in contradiction with problem definition, have minimum expected requirements and are close to goal(s) as much as possible
Decision-making implementation	Identifying criteria	Identifying attributes that distinguish alternatives with respect to the goal(s)
	Selecting the appropriate decision-making method	Knowing main features of different methods and choosing the one that is compatible with the problem's presumptions and goals, DM's preference and the one having the maximum complementary features
	Expression of DM's preferences	Translation of DM's preferences into mathematical relations
	Using chosen MADM method for evaluation	Inputting the gathered data into the model and obtaining the outputs
	Implementing sensitivity analysis	Identifying the range in which the output data remains constant by varying the input data values

This section introduces the proposed integrated MCDM methodology with Analytic Hierarchy Process (AHP) method, and *VišeKriterijumska Optimizacija I Kompromisno Rešenje* (VIKOR) method. The AHP method is used as weighting method, i.e., used to assign the weights to each criterion (presented and thoroughly described in Section 5.3.). The VIKOR method is then used as ranking method, i.e., used to rank potential alternatives, either at the same geothermal site or at different geothermal sites.

The main motivation for applying the AHP in decision making process is that, considering the contingency of the outcome, the resulting criteria weights of the AHP would be more robust than any other method. This is mainly because the hierarchy structure of AHP makes the use of detailed information inherent in the nature of the problem. Additionally, the AHP is one of the most widely used MADM methods according to the literature [93]. In fact, its hierarchical structure, which is best suited with the structure of an MADM problem, makes it more appealing for a decision-making problem.

The VIKOR method provides the maximum group utility for the majority and minimum of an individual regret for the opponent. The VIKOR method was developed as a multicriteria decision making method to solve a discrete decision problem with non-commensurable and conflicting criteria [259]. This method focuses on ranking and selecting from a set of alternatives and determines compromise solutions for a problem with conflicting criteria, which can help decision makers to reach a final decision. Here, the compromise solution is a feasible solution which is the closest to the ideal, and a compromise means an agreement established by mutual concessions [111]. The VIKOR method has been applied in this integrated MCDM methodology for alternatives ranking due to the following reasons and advantages [111]:

- 1) Compromising is acceptable for conflict resolution;
- 2) The decision maker (DM) is willing to approve solution that is closest to the ideal;
- 3) There exists a linear relationship between each criterion's function and a decision maker's utility;
- 4) The criteria are conflicting and non-commensurable (different used units);
- 5) The alternatives are evaluated according to all established criteria (performance matrix); and
- 6) The DM's preference is expressed by weights, given, or simulated.

#### 5.4.1. Weighting method – Analytic Hierarchy Process (AHP)

The simplest form for structuring the decision problem is hierarchy. This structure enables decomposition of complex problem into sub-problem levels. By doing so, the factors influencing the goal of the decision problem are organized from general ones, at the top of the hierarchy, to more specific ones, at the lower levels of the hierarchy. The purpose of the structure is to make it to allow the importance assessment of elements within the same level or in relation to the upper-level neighbour. When constructing a hierarchy, it is necessary to include enough details to represent the problem thoroughly, but not too many details to lose sensitivity in regard to elements values variations. Arranging goals, attributes, issues, and stakeholders serves two purposes. It provides a broader picture of the complex relationships between elements in the assessment process. Also, it gives the decision maker an assessment of whether the elements of the same relative size are being compared.

Advantages of hierarchy structures are [260]:

- 1) Hierarchical representation of a system can be used to describe how changes in priority at upper levels affect the priority of elements in lower levels.

- 2) Provision of great detail of information on the structure and function of a system in the lower levels and provision of an overview of the actors and their purposes in the upper levels. Constraints on the elements in a level are best represented in the adjacent higher level to ensure that they are satisfied.
- 3) Natural systems assembled hierarchically, i.e., through modular construction and final assembly of modules, evolve much more efficiently than those assembled as a whole.
- 4) Main features are stability and flexibility; stability in terms that small changes have small effect on the whole structure, and flexibility in terms that additions to a well-structured hierarchy do not disrupt the performance.

The Analytic Hierarchy Process was developed by Thomas L. Saaty in the 1970s [261] and firstly described in details in [262]. The AHP has been based on several discoveries prior to the development of the method itself. Namely, the use of pair-wise comparisons, which is the essence of the AHP method, has been used before by psychologists [263]. The hierarchical structure of the criteria (influencing factors), which is a major feature of the AHP method, was for the first time proposed in 1966 [264]. The fundamental scale of relative importance from 1-9 is based on psychological observations [265].

The AHP method is one of the decision-making processes that decomposes a complex problem into sub-problem levels in a hierarchical order, consisting of several (usually three to four) levels. The highest (top level) level in this structure defines the main goal. It is succeeded by a second level encompassing the criteria which are the major factors controlling the goal. Similarly, the third hierarchy level consists of sub-criteria affecting each major criterion, and so on (Figure 5.18). AHP process has to be as comprehensive as possible, but not that comprehensive as to lose sensitivity to change in the elements [266].

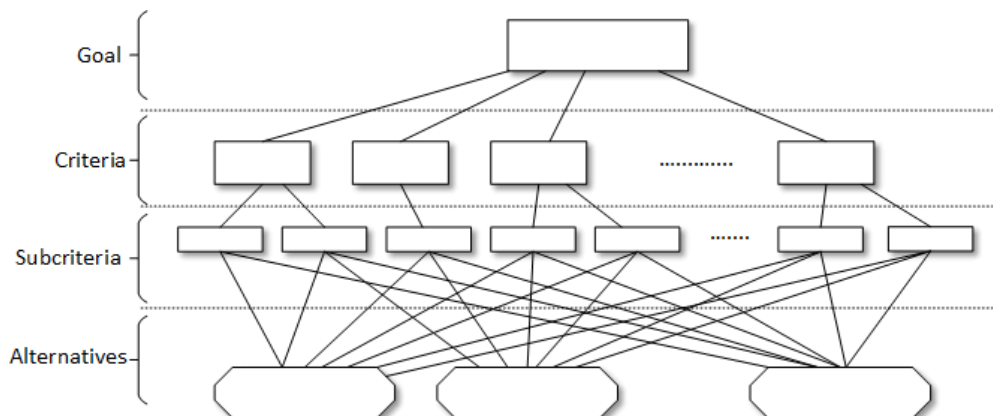

Figure 5.18. General four-level hierarchical structure in the AHP method (adapted from: [266])

#### *5.4.1.1. Primary functions of AHP method*

The AHP method has been used in a wide variety of applications which generally arises from three primary functions of AHP method. Those three functions are structuring complexity, measurement on a ratio scale, and synthesis.

With the AHP method, Saaty found a way to deal with complexity in term of structuring this complexity into homogenous clusters of factors organized in several levels. This approach is simple enough to be understood and practiced even by users with little to no formal training and experience in that regard.

Even though earlier decision-making methodologies relied on lower levels of measurement (ELECTRE using ordinal measurement and MAUT interval measurement), Saaty's mathematical background was the basis to propose the ratio scales which would most accurately measure the factors that comprised the hierarchy. Namely, the levels of measurement, ranging from lowest to highest are nominal, ordinal, interval, and ratio. Consequently, to keep a methodology as simple as possible, Saaty proposed using judgments of the ratios of each pair of factors in the hierarchy to derive (rather than assign) ratio scale measures. Any hierarchically structured methodology (like AHP and MAUT) must use ratio scale priorities for elements above the lowest level of the hierarchy. This is necessary because the priorities (or weights) of the elements at any level of the hierarchy are determined by multiplying the priorities of the elements in that level by the priorities of the parent element (from the upper level). Since the simple product of two interval level measures is mathematically meaningless, ratio scales are required for this multiplication [267].

Furthermore, while the first term in AHP method is 'analytic', which is a form of the word analysis meaning separating material or abstract entity into its constituent elements, the AHP method, apart from facilitating analysis, has the ability to provide help in measuring and synthesizing the multitude of factors in hierarchy.

#### *5.4.1.2. Principles and axioms of AHP method*

After presenting the three primary functions of AHP method, the three basic principles of AHP should also be mentioned: decomposition, comparative judgments, and hierarchic composition or synthesis of priorities [268]. The decomposition principle is applied to structure a complex problem into a hierarchy. The principle of comparative judgments is applied to construct pair-wise comparisons of all combinations of elements in a certain level with respect to the 'parent' in the upper level. These pair-wise comparisons are used to derive 'local' priorities (importance measurements) of the elements in a level with respect to their



‘parent’. The principle of synthesis of priorities is applied to multiply the local priorities of the elements by the ‘global’ priority of the ‘parent’ element producing global priorities throughout the hierarchy and then adding the global priorities for the lowest level elements which are usually the alternatives.

Every theory is based on axioms, whereas the simpler and fewer the axioms, the more general and applicable the theory. The AHP method was originally based on three axioms, and later the fourth axiom was added [269]–[271].

The AHP is founded on comparing elements (criteria, sub-criteria, alternatives) in pairs. Therefore, the focus is on scales that map pairs of elements into  $\mathbb{R}^+$  [271]. Such scales are called *fundamental* or *primitive*.

The finite set alternatives is denoted as  $\mathfrak{A}$ . Moreover, the finite set of criteria with respect to which alternatives are compared will be denoted as  $\mathfrak{C}$ . A criterion is considered as a primitive concept. When two elements  $A_i, A_j \in \mathfrak{A}$  are compared according to a criterion  $C \in \mathfrak{C}$  this represents performing binary comparison.

**Axiom 1:** (Reciprocal comparison) For all  $A_i, A_j \in \mathfrak{A}$  and  $C \in \mathfrak{C}$

$$P_C(A_i, A_j) = \frac{1}{P_C(A_j, A_i)} \quad (5.27)$$

Where the homomorphism  $P_C$  represent the intensity or strength of preference for one element over another. Additionally, for every  $A_i, A_j \in \mathfrak{A}$  and  $C \in \mathfrak{C}$  it holds that:

$$A_i \succ_C A_j \quad \text{if and only if } P_C(A_i, A_j) > 1, \quad (5.28)$$

$$A_i \sim_C A_j \quad \text{if and only if } P_C(A_i, A_j) = 1. \quad (5.29)$$

In other words, the decision maker must be able to make comparisons and state the strength of his preferences. The intensity of these preferences must satisfy the reciprocal condition: If element  $A_i$  is  $x$  times more preferred than  $A_j$ , then  $A_j$  is  $1/x$  times more preferred than  $A_i$ .

As mentioned, hierarchy is main feature of the AHP method. Let  $\mathfrak{S}$  be a finite partially ordered set with the largest element  $b \in \mathfrak{S}$ . The set  $\mathfrak{S}$  is said to be a hierarchy if it satisfies the following conditions:

- 1) There is a partition of  $\mathfrak{S}$  into sets that are called levels  $L_1, L_2, \dots, L_h$  where  $L_1 = \{b\}$
- 2)  $x \in L_k$  implies  $x^- \subseteq L_{k+1}$ , where  $x^- = \{y \text{ such that } x \succ y\}, k = 1, 2, \dots, h - 1$
- 3)  $x \in L_k$  implies  $x^+ \subseteq L_{k-1}$ , where  $x^+ = \{y \text{ such that } y \succ x\}, k = 1, 2, \dots, h$ ,

where  $x \in X$ ,  $X$  is a partially ordered set with binary relation  $\leq$  included in  $X^2$ . Additionally, for any relation  $x \leq y$  (to be read as  $y$  includes  $x$ ) the  $x < y$  is defined to mean that  $x \leq y$  and  $x \neq y$ . Furthermore,  $y$  is said to cover (dominate)  $x$  if  $x < y$  and there is no  $t$  such that  $x < t < y$ . Therefore, related to the aforementioned conditions the set  $x^-$  is bounded from above by  $x$ , whilst  $x^+$  is bounded from above by  $x$ . This is shown in Figure 5.19.

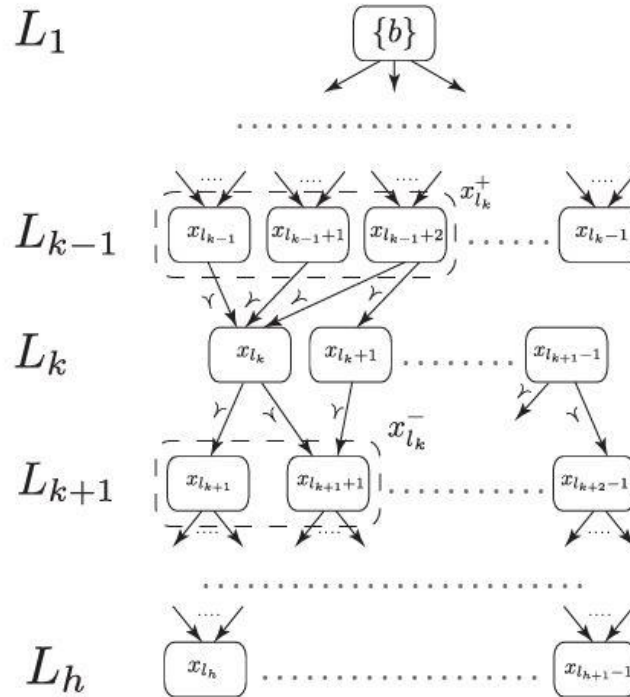

Figure 5.19. A hierarchical structure (source: [271])

Decomposition implies containment of the small elements by the large components or levels. Thus, the smaller elements depend on the outer parent elements to which they belong, which themselves fall in a large component of the hierarchy. The process of relating elements (e.g., alternatives) in one level of the hierarchy according to the elements of the next higher level (e.g., criteria) expresses the outer dependence of the lower elements on the higher elements [271]. In this way comparisons can be made between them. The steps are repeated upward in the hierarchy through each pair of adjacent levels to the top element, the focus or goal. The elements in a level may depend one on another with respect to a property in another level.

Let  $\mathfrak{A}$  be outer dependent on the set  $\mathfrak{S}$ . The elements in  $\mathfrak{A}$  are said to be *inner dependent* with respect to some  $C \in \mathfrak{S}$  if there exists  $A \in \mathfrak{A}$  so that  $\mathfrak{A}$  is outer dependent on  $A$ . Now, the second axiom can be defined.

**Axiom 2: (Independence)** When expressing preferences, criteria are assumed independent of the properties of the alternatives. Namely, let  $\mathfrak{S}$  be a hierarchy with levels  $L_1, L_2, \dots, L_h$ . For each  $L_k, k = 1, 2, \dots, h - 1$ .

1.  $L_{k+1}$  is outer dependent on  $L_k$ .
2.  $L_k$  is not outer dependent on  $L_{k+1}$ .
3.  $L_{k+1}$  is not inner dependent with respect to any  $x \in L_k$ .

Furthermore, given a positive real number  $\rho \geq 1$ , a nonempty set  $x^- \subseteq L_{k+1}$  is said to be  $\rho$ -homogenous with respect to  $x \in L_k$  if for every pair of elements  $y_1, y_2 \in x^-$  stands that  $1/\rho \leq P_x(y_1, y_2) \leq \rho$  [271]. Therefore, axiom three is defined as following.

**Axiom 3: (Homogeneity)** Given a hierarchy  $\mathfrak{H}$ ,  $x \in \mathfrak{H}$  and  $x \in L_k$ ,  $x^- \subseteq L_{k+1}$  is  $\rho$ -homogenous for  $k = 1, 2, \dots, h - 1$ .

Namely, homogeneity is essential for comparing similar things. Therefore, elements being compared should not differ by too much, otherwise there will be tendency for larger errors in judgment. When constructing a hierarchy of objectives, one should attempt to arrange elements in clusters (level) so that they do not differ by more than an order of magnitude in any cluster (level) [267].

Lastly, the fourth axiom represents expectations which are beliefs about the rank of alternatives derived from prior knowledge. Assume that a decision maker has a ranking, arrived at intuitively, of a finite set of alternatives  $\mathfrak{A}$  with respect to prior knowledge of criteria  $\mathfrak{J}$ . Furthermore, expectations are not only reflected in the structure of a decision and its completeness, but also in judgements and their redundancy to represent reality and inconsistency that should be improved with redundancy.

**Axiom 4: (Expectations)** Individuals who have reasons for their beliefs should make sure that their ideas are adequately represented for the outcome to match these expectations [267].

1. Completeness:  $\mathfrak{J} \subset \mathfrak{H} \setminus L_h$ , where  $\mathfrak{A} = L_h$ .
2. Rank: To preserve rank independently of what and how many other alternatives there may be. Alternatively, to allow rank to be influenced by the number and the measurements of alternatives that are added to or deleted from the set [271].

#### 5.4.1.3. AHP method workflow

Generally, the AHP method consists of four main steps:

1. Definition of the decision problem.
2. Structuring the hierarchy, i.e., by defining levels (as depicted in Figure 5.18 and Figure 5.19) hierarchical structure is constructed. Firstly, the goal of the decision problem must be defined, then the objectives from the broad perspective, through intermediate level (sub-criteria) to the lowest level, which usually represents alternatives.

3. Construction of a set of pair-wise comparison matrices to obtain priorities. Each element in an upper level is used to compare the elements in the level immediately below with respect to it.
4. Usage of the obtained priorities to weight the priorities in the level immediately below. This must be done for each element in the hierarchy. Then for each element in the level below its weighed values are added and its overall or global priority is obtained. This process of weighing and adding continues until the final priorities of the alternatives in the bottom most level are obtained.

The third step is a crucial step for determining weights for each element of the hierarchy. Namely, assuming  $n$  ordered comparison elements (i.e., criteria, subcriteria, or alternatives related to the criteria or subcriteria), a  $n \times n$  judgment matrix  $\mathbf{A}$  is defined (Equation (5.28)), in which each upper diagonal element  $a_{i,j} > 0$  is calculated by comparison of the  $i^{th}$  element with the  $j^{th}$  element [272]. According to axiom 1., it can be observed that the  $\mathbf{A}$  from Equation (5.30) has reciprocal properties as expressed in Equation (5.31). Therefore, the inferior triangular part of matrix  $\mathbf{A}$  is filled with the reciprocal values of the upper triangular part.

$$\mathbf{A} = \begin{bmatrix} 1 & a_{1,2} & \cdots & a_{1,n} \\ a_{2,1} & 1 & \cdots & a_{2,n} \\ \vdots & \vdots & \ddots & \vdots \\ a_{n,1} & a_{n,2} & \cdots & 1 \end{bmatrix} \quad (5.30)$$

$$a_{j,i} = \frac{1}{a_{i,j}} \quad (5.31)$$

According to [266], if  $a_{i,j}$  represents the importance of element  $i$  over element  $j$ ,  $a_{j,k}$  represents the importance of element  $j$  over element  $k$ , and  $a_{i,k}$  the importance of element  $i$  over element  $k$ , for a perfectly consistent judgment matrix  $\mathbf{A}$ , beside the expression in Equation (5.31), the following must be true:

$$a_{i,j} \cdot a_{j,k} = a_{i,k} \quad (5.32)$$

Additionally, the elements  $a_{i,j}$  of matrix  $\mathbf{A}$  are obtained by implementing the preference scale, i.e., fundamental scale. One of the strengths of the AHP method is the possibility to evaluate both quantitative and qualitative criteria and alternatives using the same preference scale. These scales can be numerical, verbal or graphical. According to [268] the ratio scales are the only possible measurement if the aggregate measurement is to be used, as in a weighted sum.

Additionally, the use of verbal scales is intuitively appealing, user-friendly, and more common in everyday life than numerical scales. However, to derive priorities, the verbal comparisons must be converted into numerical ones. In Saaty's AHP method the verbal comparisons are converted into integers from 1 to 9 as shown in Table 5.57. In theory, there is no reason to strictly follow this verbal gradation and numbers. Hence, several other numerical scales have been proposed in literature as presented in Table 5.58. However, among all the proposed scales, the linear scale with the integers 1 to 9 and their reciprocals has been used by far the most often in applications [273].

Table 5.57. Fundamental scale of relative importance (adapted from: [274])

Importance weight value, $a_{i,j}$	Value explanation
1	Two factors are equal in importance
2	1 <sup>st</sup> factor is equal to weakly more important compared to the 2 <sup>nd</sup> factor
3	1 <sup>st</sup> factor is weakly more important compared to the 2 <sup>nd</sup> factor
4	1 <sup>st</sup> factor is moderate to strongly more important compared to the 2 <sup>nd</sup> factor
5	1 <sup>st</sup> factor is strongly more important compared to the 2 <sup>nd</sup> factor
6	1 <sup>st</sup> factor is strong to very strongly more important compared to the 2 <sup>nd</sup> factor
7	1 <sup>st</sup> factor is very strongly more important compared to the 2 <sup>nd</sup> factor
8	1 <sup>st</sup> factor is very strongly to extremely more important compared to the 2 <sup>nd</sup> factor
9	1 <sup>st</sup> factor is extremely more important compared to the 2 <sup>nd</sup> factor
1/9, ..., 1/2	The reciprocal number expresses an opposite judgment

Table 5.58. Different scales for comparing two elements in the pairwise comparison matrix construction (for the comparison of A and B,  $c = a \cdot x$  indicates  $A = B$ ;  $c > 1$  indicates  $A > B$ ; when  $A < B$ , the reciprocal values  $1/c$  are used) (summarized according to: [273])

Scale type	Definition	Parameters	Reference
Linear	$c = a \cdot x$	$a > 0; x = \{1, 2, \dots, 9\}$	[262]
Power	$c = x^a$	$a > 1; x = \{1, 2, \dots, 9\}$	[275]
Geometric	$c = a^{x-1}$	$a > 1; x = \{1, 2, \dots, 9\}$ or $a > 0; x = \{1, 1.5, \dots, 4\}$ or another step	[276]
Logarithmic	$c = \log_a(x + (a - 1))$	$a > 1; x = \{1, 2, \dots, 9\}$	[277]
Root square	$c = \sqrt[a]{x}$	$a > 1; x = \{1, 2, \dots, 9\}$	[275]
Asymptotical	$\tanh^{-1}\left(\frac{\sqrt{3} \cdot (x - 1)}{14}\right)$	$x = \{1, 2, \dots, 9\}$	[278]
Inverse linear	$c = 9/(10 - x)$	$x = \{1, 2, \dots, 9\}$	[279]
Balanced	$c = w/(2 - w)$	$w = \{0.5, 0.55, 0.6 \dots, 0.9\}$	[280]

After all comparison (judgement) matrices have been constructed, the weights can be calculated using the following eigenvector problem:

$$\mathbf{A} \cdot \mathbf{w} = \lambda_{max} \cdot \mathbf{w}, \quad (5.33)$$

where  $\mathbf{w}$  is the priority vector ( $\mathbf{w} = [w_1, \dots, w_n]^T$ ) and  $\lambda_{max}$  is the judgement matrix  $A$  largest eigenvalue. Namely, the matrix  $\mathbf{A}$  and the statement in Equation (5.33) is true only and only if there exist positive numbers  $w_i > 0$ ,  $i = 1, \dots, n$ , such that the  $a_{i,j} = w_i/w_j$ . Moreover, in case that it is assumed that the matrix  $\mathbf{A}$  is consistent, it can be concluded that  $\lambda_{max} = n$ . However, if slightly inconsistencies are introduced, it stands that  $\lambda_{max} \neq n$ , and for a reciprocal matrix it is always  $\lambda_{max} \geq n$  [266], [274]. The matrices expressed in Equation (5.30) are obtained for each cluster in each level (criteria, sub-criteria, and alternatives). Furthermore, to calculate the weights from the comparison matrices, approximative formulations are used and this process can be explained in three main steps. The first step here is to normalize the elements of matrix  $\mathbf{A}$  using the Equation (5.34). Then the normalized matrix  $\mathbf{A}$  is obtained. The second step is to calculate the weights  $w_i$  as the average of the rows of the normalized matrix  $\mathbf{A}$ , as expressed in Equation (5.35).

$$x_{i,j} = \frac{a_{i,j}}{\sum_i a_{i,j}} \quad (5.34)$$

$$w_i = \frac{\sum_{j=1}^n x_{i,j}}{n} \quad (5.35)$$

The third step is to evaluate the obtained weights, i.e., the consistency of the comparison matrix needs to be checked. Poor judgement is reflected in increased inconsistency of the comparison matrix. To check the consistency of the comparison matrix, the largest eigenvalue is approximately calculated according to Equation (5.36). Namely, the simplest way to calculate  $\lambda_{max}$  when the normalized values of weights  $w_i$  are calculated is to sum each column of the comparison matrix and then multiply i) the sum of the first column by the value of the first element of the normalized priority vector  $\mathbf{w}$ , ii) the sum of the second column by the value of the second element and so on as shown in Equation (5.36). The final step is to add the resulting numbers [274].

$$\lambda_{max} = \sum_{i=1}^n \left[ \left( \sum_{j=1}^n a_{i,j} \right) \cdot w_i \right] \quad (5.36)$$

It can be observed that a small changes in  $a_{i,j}$  imply a small change in  $\lambda_{max}$ , therefore the deviation of the  $\lambda_{max}$  from  $n$  can be taken as a measure of consistency. This measure is called consistency ratio (CR) and it is defined as the ratio between consistency index (CI) and its expected value, a random index (RI) which is related to the number of attributes used in the

decision-making process. Therefore, after calculating the  $\lambda_{max}$  the CI is calculated using the Equation (5.37). Then the CR can be calculated using the Equation (5.38). The matrix **A** will be considered as an acceptable and appropriate presentation of consistency among chosen criteria if the CR value is less than 0.1, i.e. less the 10% [101] (for larger number of criteria, a bigger value of 0.15 can be used, as presented in [281]–[283]). If the CR is not within this range, the decision maker (user of the AHP methodology) should study the problem from the beginning and revise the comparison matrix, i.e., reconstruct it.

$$CI = \frac{\lambda_{max} - n}{n - 1} \quad (5.37)$$

$$CR = \frac{CI}{RI} \quad (5.38)$$

Various authors have computed and obtained different values of RI depending on the simulation method and the number of generated matrices involved in the process [284]. The RI values used in this thesis are based on the [285] and are shown in Table 5.59.

Table 5.59. Random consistency index (RI) (source: [285])

<b>n</b>	1	2	3	4	5	6	7	8	9	10	11	12	13	14	15
<b>RI</b>	0	0	0.49	0.82	1.03	1.16	1.25	1.31	1.36	1.39	1.42	1.44	1.46	1.48	1.49

Once all the comparison matrices have been checked for the consistency and they meet the conditions of consistency, meaning also the local weights calculated according to Equations (5.32) and (5.33) are acceptable and representative, the global weights can be calculated. Namely, elements in each level are mutually compared with respect to the element in the upper level that they are related to (their ‘parent’). Priorities,  $w_i$ , obtained from those comparisons are used to obtain local weights of elements in each level. This is done for every element [286], except for the first level that contains the goal. According to [274], the global weights are synthesized from the second level downwards. The weights of the associated criterion in the level above are multiplied and summed for each element in a level associated to the criteria group it affects.

Any complex situation that requires structuring, measurement, and and/or synthesis is a good candidate for AHP. However, AHP is rarely used in isolation. Rather, it is used along with, or in support of other methodologies. Therefore, in this integrated MCDM methodology the AHP method is used solely for weighting of the criteria.

#### 5.4.1.4. Case study

As mentioned, it is very important to emphasize that the preferences of each decision maker can highly influence the outcome of a decision-making process. Namely, even though the MCDM method provides standardized way of making a decision, a certain level of subjectivity is always expected and present. Therefore, this Section will provide detailed analysis of results of applying AHP method as weighting method in MCDM process.

The MCDM methodology (Figure 5.20) used in this case study consists of combining of method for standardized evaluation of defined influencing criteria with AHP method, including the weighted decision matrix (WDM) used to obtain the final grades for each scenario. The starting point was the definition of the influencing criteria described in Section 5.2.2, then each criterion was graded based on the method for standardized evaluation of defined influencing criteria described in Section 5.3.1. Afterward, the weights were assigned to each criterion based on their relative importance and applying the AHP method described in Section 5.4.1. In MCDM methodology proposed in this case study, i.e., analysis, the weighted sum method (WSM) was used to obtain the final assessment, i.e., final grade of each scenario presented in Section 5.3.2. Namely, the final project's grade  $X_k$ , of  $k^{\text{th}}$  EGS option based on all criteria is obtained by summarizing of all performance values,  $x_{kl}$ , of twenty-eight influencing factors, i.e., criteria, multiplied by associated weight calculated with the AHP method using Equation (5.39):

$$X_k = \sum_l^L x_{kl} \cdot w_l \quad (5.39)$$

$$x_{kl} \in \{1, 2, 3, 4, 5\},$$

where  $X_k$  is the cumulative performance of  $k^{\text{th}}$  EGS option,  $k \in K$ ,  $K$  is a cumulative number of EGS options, the  $w_l$  is weight of criterion  $l$ ,  $l \in L$ ,  $L$  represents a cumulative number of criterions.

The MCDM methodology was applied on the same dataset as presented and described in Section 5.3.2 (Table 5.48-Table 5.50). Namely, the MCDM methodology was applied to assess and to compare two scenarios for both sites, namely heat production and electricity generation scenarios.



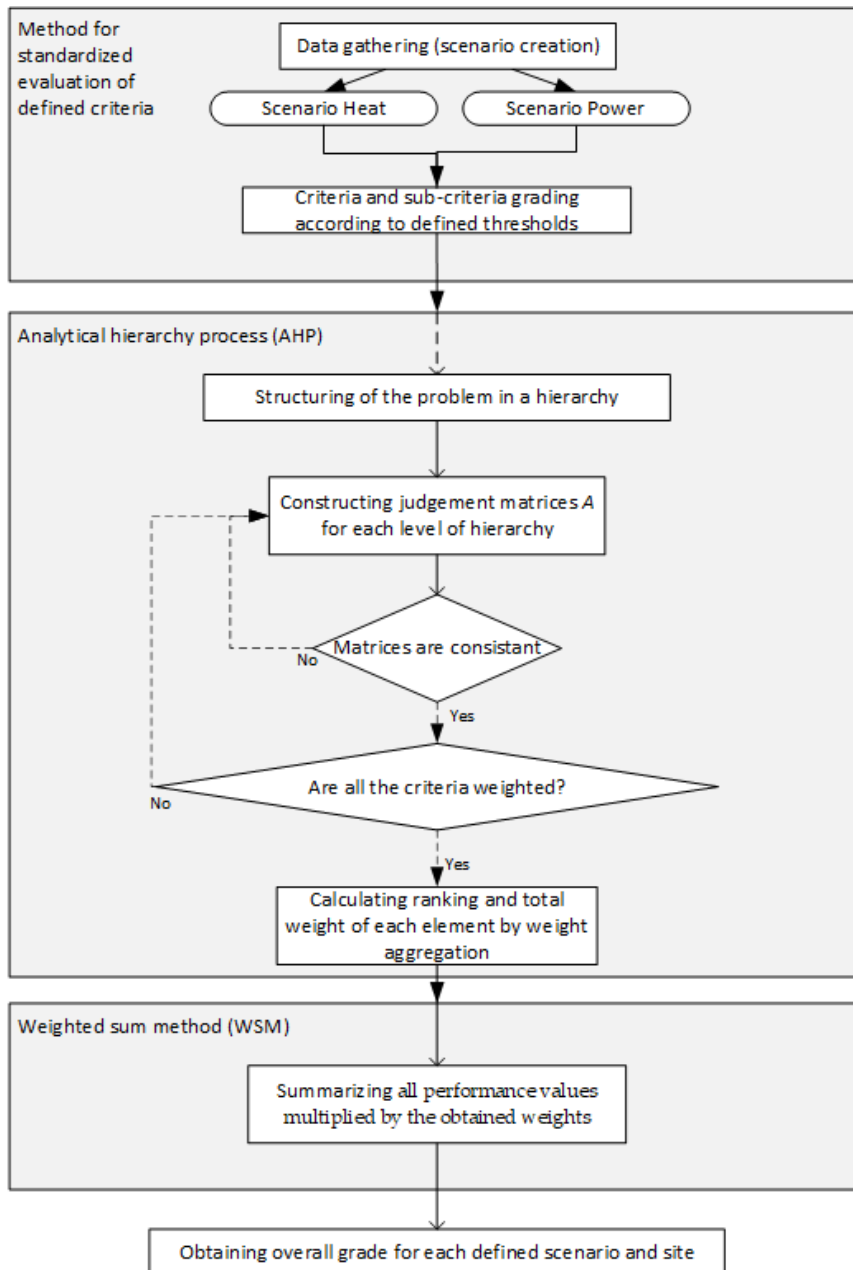

Figure 5.20. Scheme of MCDM methodology applied in the case study

#### 5.4.1.4.1. AHP hierarchical structure

Starting point of AHP method is to decompose the decision problem into a hierarchical structure (as depicted Figure 5.18). Therefore, in the first (top) level is the overall goal, i.e., selection of best utilization option of potential enhanced geothermal site. In the second level of hierarchy are five main criteria, i.e., five main groups of influencing criteria: geological setting, technology, economy/finance, society, and environment (as depicted in Figure 5.4). In the third level are twenty-eight criteria defined in Section 5.3, which are here labelled as ‘sub-criteria’ (Figure 5.21).

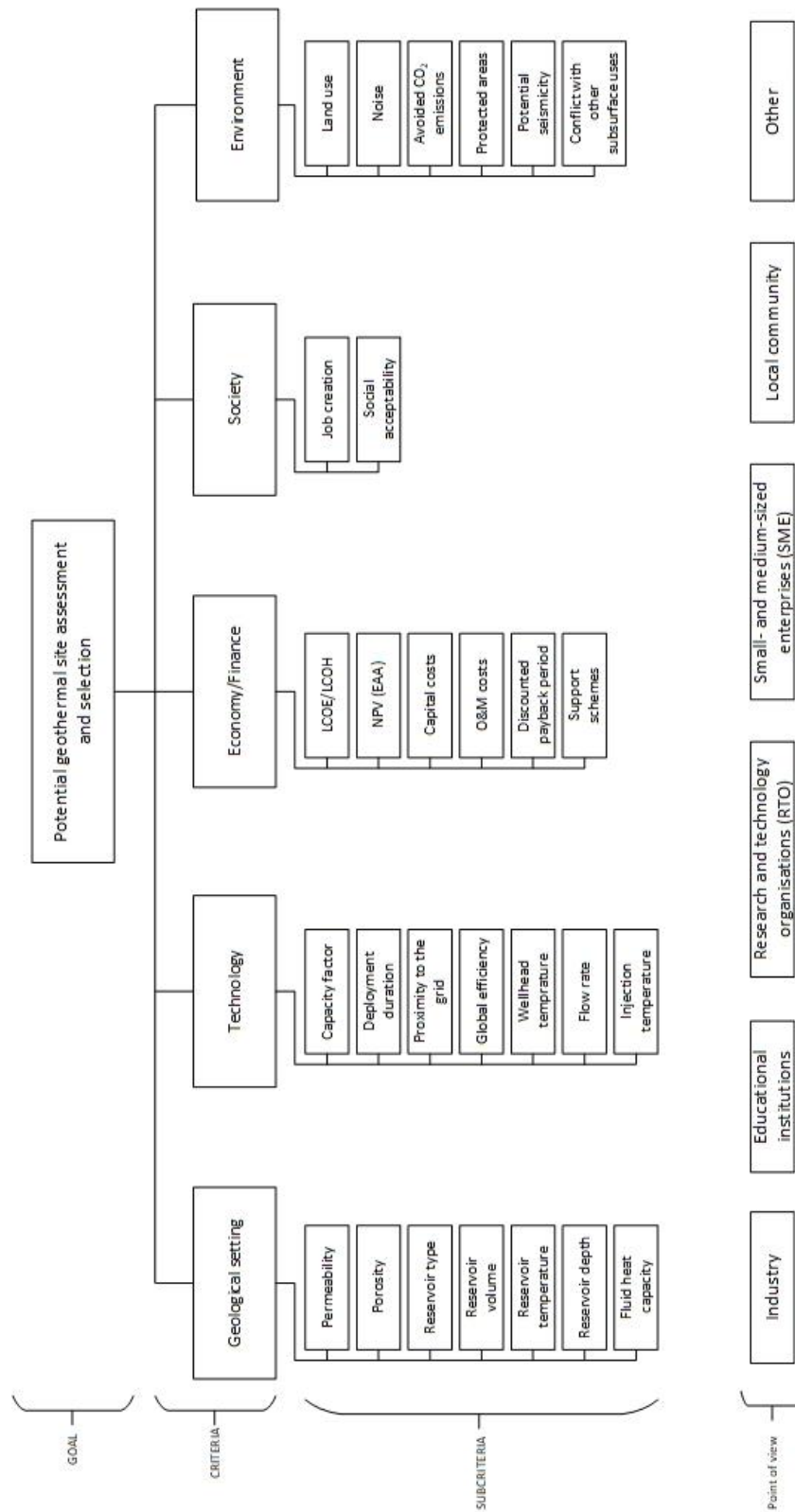

Figure 5.21. The hierarchical structure of the decision-making problem used in the case study

Furthermore, to calculate the weights of each influencing factor in the AHP method, a survey was conducted among six different categories of 38 experts in total, where each group

represented a specific point of view. The categories were determined according to the organization type that the experts work for or belong to: industry, educational institution, research and technology organization (RTO), small- and medium-sized enterprises (SME), local community and other. Some of the experts were also included in the process of the criteria and subcriteria definition and determination (Section 5.2.2). A weighted geometric mean was used in order to aggregate individual judgments into a single representative judgement related to specific group [286].

#### 5.4.1.4.2. Results (combined) and discussion

Based on the proposed AHP method described in Section 5.4.1.3, the Excel-based AHP survey was developed and distributed to the experts from six different categories. The purpose of the survey was to collect different results from various experts involved in geothermal energy projects planning, modelling, and development to see how the expertise background and different knowledge level of potential investors influence the final decision on investing in EGS energy utilization project.

The number of samples and the consistency passing ration of each category of respondents to the total number of samples are summarized in Table 5.60. The table also shows the consistency test results of the 38 respondents. In this case study, consistency ratio (CR) of 0.15 was applied. According to [287] CR value greatly depends on the size of the matrix. Additionally, CR depends also on the characteristics of the sample target group. According to [288] for expert individuals, CR is restricted to range between 0.10 and 0.15. According to the same reference, in the case of group responds that include non-expert responds, CR could be relaxed to 0.20. Three respondents did not achieve to pass the consistency ratio. Thus, the analysis results are based on the responses of the remaining 35 participants.

Additionally, the respondents were also grouped according to their professional background (Table 5.61). First group consist of respondents with geological background and second of respondents with engineering background, i.e., with no (or very little) geological background.

Table 5.60. Contribution of AHP respondents by organization

	Industry	Educational institution	Research and technology organisation (RTO)	Small- and medium-sized enterprises (SME)	Local community	Other	TOTAL
Number of respondents (persons)	4	10	7	14	1	2	38
Number of respondents with CR < 0.15	4	9	5	14	1	2	35
Consistency passing ratio (%)	100.00	90.00	71.43	100.00	100.00	100.00	92.11

Table 5.61. Contribution of AHP respondents by background

	Geological background/science	Engineering background (no geological background)	TOTAL
Number of respondents (persons)	23	15	38
Number of respondents with CR < 0.15	21	14	35
Consistency passing ratio (%)	91.30	93.33	92.11

Pair-wise comparison matrices were constructed for each level of hierarchy. The AHP process was applied to each matrix using the steps from Equation (5.28.) – Equation (5.36). Individual comparison matrices of each respondent were aggregated into a single representative matrix using a weighted geometric mean. The pair-wise comparison matrices associated to criteria and sub-criteria level for combined results and considering all category groups are shown in Appendix A (Table A.1-Table A.6). Moreover, normalized pair-wise comparison matrices are shown in Appendix A (Table A.7-Table A.12), where the consistency of each matrix is determined and checked and the local weight, i.e., priority vector is obtained for each hierarchy level.

The results for second level (criteria level) weights and local and global weights of the third level (sub-criteria level) for all groups as one group are shown in Table 5.62. Additionally, the ranking of all sub-criteria based on their global weights is presented. Global weights of sub-criteria were obtained by multiplying the local weight of sub-criteria in second level with corresponding local weight of criteria in first level.

When analysing the criteria level of hierarchy (Table 5.62), it is indicative that the geological setting criteria group (30.39%) was considered as the most important group, followed by economy/finance (23.33%), technology (17.83%), environment (15.80%), and society (12.66%) as least important. Higher weights were assigned to the criteria that directly affect the project profitability. Namely, geothermal projects and especially EGS projects have high upfront costs and are very capital-intensive projects. Moreover, the geological conditions

at specific geothermal site have high impact on the capital investments and the lifetime profitability of such projects. Therefore, the geological criteria setting showed the highest relative importance.

Table 5.62. Summarized local and global weights for each element in criteria and sub-criteria level of the hierarchy, and ranking of the elements in sub-criteria level

Criteria	Local weight	Subcriteria	Local weight	Global weight	Rank
Geological setting	0.30392	Permeability	0.2040	0.0620	3
		Porosity	0.1177	0.0358	12
		Reservoir type	0.0931	0.0283	20
		Reservoir volume	0.1316	0.0400	10
		Reservoir temperature	0.2185	0.0664	1
		Reservoir depth	0.1228	0.0373	11
		Fluid heat capacity	0.1124	0.0342	14
Technology	0.17825	Capacity factor	0.1610	0.0287	19
		Deployment duration	0.0851	0.0152	27
		Proximity to the grid	0.1284	0.0229	22
		Global efficiency	0.1893	0.0338	15
		Wellhead temperature	0.1536	0.0274	21
		Flow rate	0.1890	0.0337	16
		Injection temperature	0.0935	0.0167	25
Economy/Finance	0.23329	LCOE/LCOH	0.1484	0.0346	13
		NPV (EAA)	0.1752	0.0409	9
		Capital costs	0.1785	0.0416	8
		O&M costs	0.0880	0.0205	24
		Discounted payback period	0.1849	0.0431	6
		Support schemes	0.2251	0.0525	5
Society	0.12656	Job creation	0.4883	0.0618	4
		Social acceptability	0.5117	0.0648	2
Environment	0.15799	Land use	0.1000	0.0158	26
		Noise	0.0848	0.0134	28
		Avoided CO <sub>2</sub> emissions	0.2079	0.0328	17
		Protected areas	0.1947	0.0308	18
		Potential seismicity	0.2713	0.0429	7
		Conflict with other subsurface uses	0.1413	0.0223	23

In the geological setting group of criteria, the reservoir temperature was assigned with the highest relative importance (21.85%), followed by permeability (20.40%) as the second. The reservoir temperature determines the possible end-usage options as depicted and described in [145] and is relatively easy to measure and understand very early in the project. Namely, for higher reservoir temperatures the range of the end-usage options is wider which also

diversifies the risk of reaching the potential end-users and enables higher profits from that point of view. Permeability is considered as the second relative important sub-criterion in this criteria group which is because the natural permeability determines the extent of enhancement process. Namely, to improve the permeability of the fractured systems and thereby the productivity of the reservoir, low permeable rocks are artificially enhanced or engineered by different stimulation techniques, allowing thereby the fluid flow through newly created fractures, and capturing the heat of the rock and transferring it to the surface via production well system. Also related to the artificial creating of the reservoir are the third and the fourth relative important sub-criteria in this criteria group, reservoir volume (13.16%) and reservoir depth (12.28%) respectively. For sustainable deep geothermal energy exploitation, it is more beneficiary to have larger reservoir volumes which extends the reservoir's lifetime and avoids the premature exploitation of the resource. AS mentioned, EGS technology enables reaching deeper and previously inaccessible reservoirs and depths. However, reservoir depth represents great challenge for project developers because deeper wells are associated with longer drilling operations which increases the cost of the whole process and arises the risks related to the drilling operations. Reservoir porosity (11.77%), fluid heat capacity (11.24%) and reservoir type (9.31%) are the last three geological setting sub-criteria in terms of relative importance.

In the economy/finance criteria group, the support schemes were assigned with the highest relative importance (22.51%). This was predictable because the potential market for geothermal energy is still immature, and improvements, development, and demonstration of fully functional EGS plants are awaited. In this regard, the support schemes of any kind are still a necessity considering EGS projects economic profitability. Second most important sub-criterion under economy/finance criteria was the discounted payback period (18.49%), followed by the capital costs (17.85%) and NPV(EAA) (17.52%). From the investors point of view the projects with shorter payback periods are more appealing since the EGS projects are very capital intensive. Capital costs vary significantly since the geothermal projects are very site specific and the geothermal energy market is still relatively weak. Slightly less important showed to be the NPV(EAA) (17.52%), which is related to the profit maximization, and LCOE/LCOH (14.84%) related to the cost minimization. Least important are the O&M costs (8.8%), which was also predictable since they depend on installed capacity, i.e. are assumingly proportional to the energy production and follow an exponential decline with increasing plant capacity [289].

In the technology criteria group, the global efficiency (18.93%) and flow rate (18.90%) sub-criteria were associated with the highest relative importance. The flow rate together with

the wellhead temperature, ranked as the fourth influencing sub-criterion in this criteria group (15.36%) dictate the expected amount of extracted heat from the reservoir and used in the conversion process to generate electricity, produce heat or both. The capacity factor is ranked as third (16.10%) and generally reflects the produced energy. Higher capacity factor indicates that the actual produced energy in a given period is close to the maximum possible energy production. Proximity to the grid, either power grid or heating network, can impose significant barriers for the project to be implemented because of the high costs of connection. However, it is assumed that the geothermal plants are located rather near to the end-users. Therefore, the relative importance of this sub-criterion placed it in the fifth place (12.84%) in this criteria group. The two least important sub-criteria in this criteria group were injection temperature (9.35%) and deployment duration (8.51%). The injection temperature depends on the amount of produced energy and wellhead temperature. It is not considered as very important since it does not have huge influence in the overall conversion process compared to other sub-criteria, however, it is important in terms of long-term management strategy. The duration of each phase in the geothermal project usually does not vary to much from project to project, and it is therefore relatively easy to anticipate the overall duration of the project. However, some risks should be considered, especially in the drilling phase.

The biggest environmental impacts when assessing EGS projects are related to the well drilling and stimulation of the reservoir. From the results, the potential seismicity was associated with the highest relative importance in environmental group of criteria (27.13%) which implies that the potential investors, i.e., subjects involved in EGS projects are aware of the risks related to such projects based on the worldwide experience with the implementation of EGS projects. The avoided CO<sub>2</sub> emissions sub-criterion follows the potential seismicity as the second relative important sub-criterion (20.79%). The protected area sub-criterion is placed as third important (19.47%) because the geothermal potential is often located in protected areas (national parks, protected forests, etc.) or near restricted areas (rivers, roads, etc.). Other important issue when developing EGS projects is the potential conflict with other subsurface uses (14.13%). Therefore, prior to allocation of subsurface resource the range of potential available resources and potential uses in the targeted area must be known. Last two relative important sub-criteria are land use (10.00%) and noise (8.48%) which is expected because the geothermal power plants have small land use intensity and during operation the only noise sources are transformers and cooling fans.

Social acceptability (51.17%) and job creation (48.83%) showed almost equal relative importance with social acceptability being slightly more important. This is expected since social acceptance allows the creation of new jobs.

The results of the global weight for the sub-criteria level are shown in Figure 5.22. Reservoir temperature is regarded as the most influencing factor (6.64%) followed by, social acceptability (6.48%), permeability (6.20%) and job creation (6.18%). Two geological setting sub-criteria have also high global weights since the geological setting criteria was associated with the highest local weight. Social acceptability and job creation ranking is result of high local weights. Additionally, the question of societal acceptance of geothermal project, especially large ones, depends on the public opinion and perception of a new EGS project. Therefore, both of these sub-criteria are identified as highly important. In the top ten most important sub-criteria are also support schemes (5.25%), discounted payback period (4.31%), potential seismicity (4.29%), capital costs (4.16%), NPV(EAA) (4.09%), and reservoir volume (4.00%). As it can be seen, the economic criteria dominate the first third of the ranking of the most important sub-criteria which is expectable since geothermal projects are capital intensive and that the geothermal market, including EGS market is yet to experience full grow. The last five ranked sub-criteria include O&M costs (2.05%), injection temperature (1.67%), land use (1.58%), deployment duration (1.52%), and noise (1.34%). Hence, these results suggest that for adequate investment in EGS project many different aspects should be carefully considered, simultaneously considering the complex interactions between socio-environmental, techno-economic, and geological influencing factors.

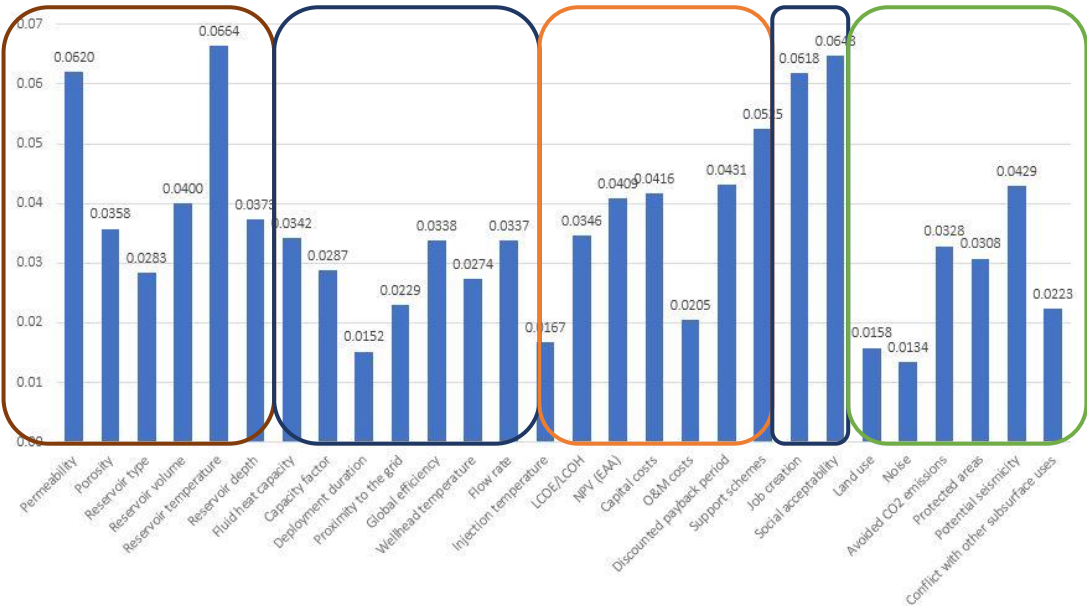

Figure 5.22. Results for the sub-criteria level - global weights (colour of the rectangles is associated with the criteria level: brown - geological setting criteria; blue - technology criteria; orange - economic criteria; blue - social criteria; green – environmental criteria)



After the AHP weights have been calculated and the grading of each criterion (which was done and presented in Section 5.3.1) for ‘Scenario Heat’ and ‘Scenario Electricity’ the final grade for each site and scenario can be calculated using the WSM method. The obtained results are shown in Table 5.63.

Table 5.63. Final grading of each site and each scenario when the AHP-WSM method is applied

	Parameter	Scenario Heat		Scenario Electricity	
		Site 1	Site 2	Site 1	Site 2
Geological setting	Permeability	0.1860	0.1860	0.1860	0.1860
	Porosity	0.1073	0.1073	0.1073	0.1073
	Reservoir type	0.0849	0.0849	0.0849	0.0849
	Reservoir volume	0.1600	0.1600	0.1600	0.1600
	Reservoir temperature	0.3320	0.3320	0.3320	0.3320
	Reservoir depth	0.1120	0.1493	0.1120	0.1493
Technology	Fluid specific heat capacity	0.1025	0.1025	0.1025	0.1025
	Capacity factor	0.1429	0.1429	0.0857	0.0571
	Deployment duration	0.0742	0.0742	0.0742	0.0742
	Proximity to the grid	0.1176	0.0941	0.1176	0.0941
	Global efficiency	0.1686	0.1686	0.0337	0.0337
	Wellhead temperature	0.0275	0.1375	0.0275	0.1375
Economy/ Finance	Flow rate	0.1334	0.1334	0.1334	0.1334
	Injection temperature	0.0836	0.0669	0.0836	0.0669
	LCOE/LCOH	0.1038	0.1730	0.0692	0.1730
	NPV (EAA)	0.0409	0.2043	0.0409	0.2043
	Capital cost	0.1665	0.2082	0.2082	0.2082
	O&M cost	0.0411	0.0821	0.0616	0.0616
Society	Discounted payback period	0.0431	0.2157	0.2157	0.2157
	Support schemes	0.1050	0.1050	0.2100	0.2100
	Job creation	0.2472	0.1854	0.1854	0.1854
Environment	Social acceptability	0.2590	0.2590	0.2590	0.2590
	Land use	0.0790	0.0790	0.0790	0.0790
	Noise	0.0670	0.0670	0.0670	0.0670
	Avoided CO2 emissions	0.1314	0.1314	0.0985	0.0985
	Protected area	0.1538	0.1538	0.1538	0.1538
	Potential seismicity	0.1714	0.1714	0.1714	0.1714
	Conflict with other subsurface uses	0.1116	0.1116	0.1116	0.1116
<b>FINAL GRADE</b>		<b>3.5534</b>	<b>4.0866</b>	<b>3.5718</b>	<b>3.9176</b>

The methodology can be used to compare different geothermal sites for the same scenario. For ‘Scenario Heat’, the Site 2 obtained higher final grade (4.0866) than Site 1 (3.5534). From the results it can be concluded that the wellhead temperature sub-criterion is more favourable for the Site 2, which is in close relationship with reservoir depth, that is also more favourable for the Site 2. As mentioned, since both geothermal sites are located in similar geological settings, the economic criteria group will have great influence in the final grade of the sites for a specific scenario. Therefore, since all economic criteria are more favourable for

the Site 2 than for Site 1 for the heat production scenario, the final grade is mostly dependent on these criteria. In ‘Scenario Electricity’ Site 2 obtained much higher grades for two main economic sub-criteria LCOE and NPV compared to Site 1. For this scenario larger difference between production (wellhead) temperature and injection temperature, as much as higher flow rate leads to the higher installed capacity potential, and thereby the larger amount of produced energy which consequently leads to better economics of the project.

The methodology can also be used to compare different scenarios at the same geothermal site. According to the results, when ‘Scenario Heat’ and ‘Scenario Electricity’ are compared for the Site 1, ‘Scenario Electricity’ is slightly more favourable with the final grade of 3.5718. The most influencing sub-criteria which lead to this result are economic sub-criteria: capital costs, O&M costs, discounted payback period, and support schemes (which have higher grade for the electricity generation scenario compared to the heat production scenario). This again confirms the importance of economic criteria group in the created case study. In the case of Site 2, ‘Scenario Heat’ is more favourable with the grade of 4.0866 compared to ‘Scenario Electricity’ grade of 3.9176. These results are derived from the fact that some technology related sub-criteria, such as capacity factor and global efficiency, and some economic sub-criteria, such as O&M costs, are associated with better grades.

If a comparison between results obtained in Section 5.3.2 and results obtained in this section is conducted, it can be concluded that by applying AHP method, the final grades for each site and scenario decrease (as shown in Figure 5.23). Namely, in the case study in Section 5.3.2 all the criteria are assumed to be equally important, i.e., assigned weights were equal to 1 for each criterion, whereas by applying AHP method, the importance of each criterion changes slightly or significantly. However, it is never equal to 1. Therefore, it can be concluded that by conducting the AHP, the final grades are reflecting better the decision makers’ preferences and can therefore also change the final decision. This is particularly observable for Site 1. Namely, in case when AHP is not used, the ‘Scenario Heat’ is assessed as better option (3.6786) compared to ‘Scenario Electricity’ (3.6429). In contrary, when the AHP method is applied the ‘Scenario Electricity’ is assessed as better option (3.578) compared to ‘Scenario Heat’ (3.5534).

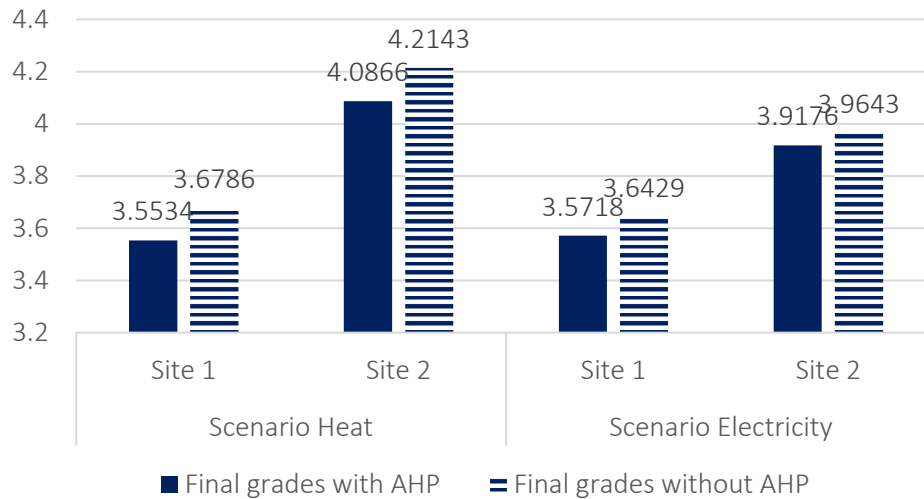

Figure 5.23. Comparison of final grades for both sites and scenarios – results with and without applying AHP method

#### 5.4.1.4.3. Detailed analysis of results by stakeholder group

Since there are various interested parties in the geothermal energy market it is important to analyse the different perspectives of stakeholders. Even though, the goal of investment in geothermal energy projects is common, individual stakeholders may see the relative importance of each sub-criterion differently. Therefore, considering this, the differences in perspective of various stakeholders can highly influence the decisions. The stakeholders include researchers (working in educational institutions or research and technology organisations) that are directly or indirectly related to policy establishment and regulatory framework, financial investors from industry or small-and-medium sized enterprises, who are the main players in the geothermal power market, as well as local community. The survey was analysed separately for each group of stakeholders. Figure 5.24 shows the criteria level relative importance for different stakeholder groups.

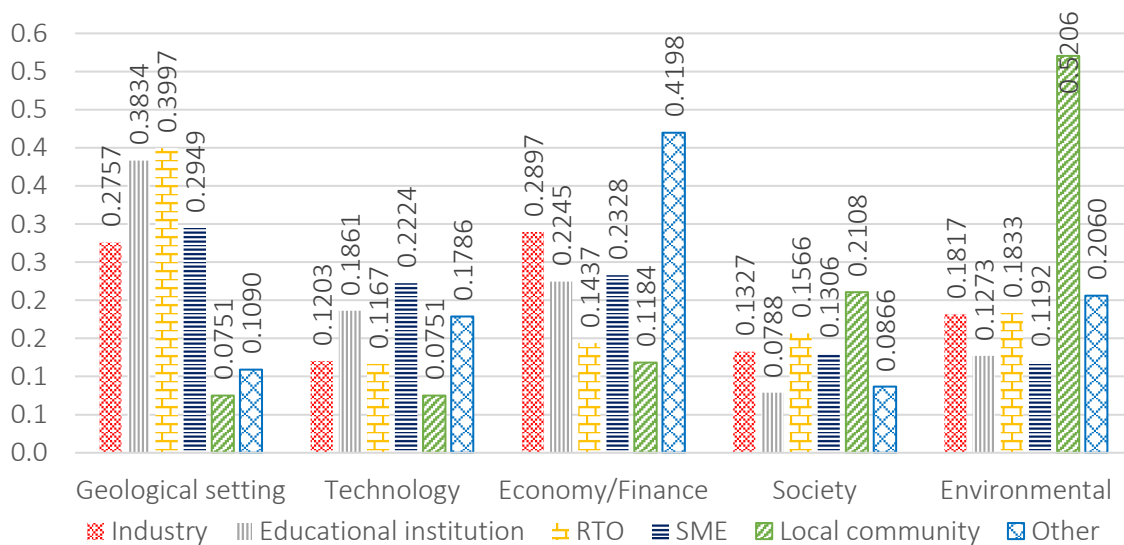

Figure 5.24. Analysis results for the criteria level for each stakeholder group

The geological setting criteria group was assigned with the highest weight for most of the stakeholder groups apart from local community group and couple participants that do not fit into any of the five defined stakeholder groups and are therefore labelled as ‘other’. This is expected because the geological setting criteria may be accounted as a basis for the future development of a geothermal project. For industry and ‘other’ stakeholders, the economy criteria showed the highest weights, 28.97% and 41.98%, respectively. Stakeholders from educational institutions and SME also weighted the economy criteria with high relative importance, positioning it on the second place with 22.45% and 23.28%, respectively (Table 5.64). It can also be observed that the educational institution group has almost same preferences as SME group considering the criteria level. Namely, both groups ranked geological setting criteria, economy/finance criteria, and technology criteria as first, second, and third, respectively. Difference is visible for fourth and fifth place, where educational institution group considers environment criteria more important than societal criteria. As expected, criteria groups that mostly reflect the local impact of a geothermal project, namely environment (52.06%) and society (21.08%), had the highest weights for local community stakeholder group. Namely, local community is mostly impacted by the geothermal project in terms of job creation and different impact on the local environment. The groups showed the biggest differences in weighting environment criteria since it widely ranges from the first to the last, depending on the stakeholder group (Table 5.64).

Table 5.64. Ranking of the elements in the criteria level for each stakeholder group and combined results (all respondents as one group)

	Industry	Educational institution	RTO	SME	Local community	Other	COMBINED RESULTS
Geological setting	2	1	1	1	5	4	1
Technology	5	3	5	3	4	3	4
Economy/Finance	1	2	4	2	3	1	2
Society	4	5	3	4	2	5	5
Environment	3	4	2	5	1	2	3

The difference in perspective among different stakeholder groups is even more noticeable when the sub-criteria level is analysed (Table 5.65). The stakeholders from local community group evaluate the sub-criteria from environment and society criteria groups with highest importance, ranking the first eight sub-criteria as follows: potential seismicity (19.58%), job creation (15.81%), conflict with other subsurface uses (11.97%), protected areas (8.71%), social acceptability (5.27%), avoided CO<sub>2</sub> emissions (5%), land use (3.4%), and noise (3.4%).

Stakeholders from industry are favouring the economic criteria, followed by society criteria, and geological setting criteria group. Namely, such companies usually carry out the

entire EGS development process from the initial investment stage to the operation of power plants. The discounted payback period was assigned with the highest importance (6.99%), followed by social acceptability (6.87%), LCOE/LCOH (6.79%), job creation (6.40%), and NPV(EAA) (6.09%). As it can also be observed, the weight distribution was more uniform for the industry stakeholder group compared to the local community. Namely, the relative importance of the first third of the ranked criteria ranges between 6.99% and 5.03%.

Small-and-medium scale enterprises stakeholders showed more heterogenous ranking, especially in the first third of the ranked sub-criteria. Social acceptability (6.82%) and job creation (6.24%) are ranked as first and third important sub-criteria. SME may operate locally or globally; however, their core business is highly influenced by the social aspects of EGS projects. This observation applies similarly also to other stakeholder groups. Second and fourth most important sub-criteria are from the geological setting criteria group. Reservoir temperature (6.27%) which directly influences the potentially produced energy and permeability (6.24%). The potential profit from produced energy is important for SME since they have relatively small budget. Therefore, the support schemes (5.57%) are also ranked high, as fifth most important sub-criterion.

Two stakeholder groups whose perspective is related to the research have more or less similar preferences for different sub-criteria. Both, educational institutions (11.6%) and research and technology organizations (RTO) (11.06%) put the highest importance for the society criteria group, social acceptability. Both stakeholder groups ranked the geological setting related sub-criteria very high with only difference in ranking reservoir type which is from the perspective of educational institutions ranked as the twenty-first important sub-criterion and from the perspective of RTO as sixth.

Detailed results for each criteria level group and each stakeholder group are shown in graphs in Appendix A (Figure A.1–Figure A.5). The graphs in Appendix A show the local weights of criteria from the perspective of each stakeholder group.

Table 5.65. Ranking for the sub-criteria level (according to global weights) for each stakeholder group and combined results (all respondents as one group) (for comparison)

	Industry	Educational institution	RTO	SME	Local community	Other	COMBINED RESULTS
<i>Permeability</i>	10	2	2	4	25	22	<b>3</b>
<i>Porosity</i>	17	5	4	19	26	23	<b>12</b>
<i>Reservoir type</i>	21	20	6	16	22	27	<b>20</b>
<i>Reservoir volume</i>	7	4	3	11	21	28	<b>10</b>
<i>Reservoir temperature</i>	9	1	5	2	12	11	<b>1</b>
<i>Reservoir depth</i>	6	14	19	10	11	20	<b>11</b>
<i>Fluid heat capacity</i>	19	8	11	17	14	19	<b>14</b>
<i>Capacity factor</i>	14	21	16	13	23	14	<b>19</b>
<i>Deployment duration</i>	27	27	28	21	28	26	<b>27</b>
<i>Proximity to the grid</i>	26	23	24	20	13	13	<b>22</b>
<i>Global efficiency</i>	23	16	17	9	15	7	<b>15</b>
<i>Wellhead temperature</i>	28	7	25	18	16	16	<b>21</b>
<i>Flow rate</i>	24	11	26	6	19	12	<b>16</b>
<i>Injection temperature</i>	18	22	27	26	24	21	<b>25</b>
<i>LCOE/LCOH</i>	3	17	12	15	20	15	<b>13</b>
<i>NPV (EAA)</i>	5	10	20	11	18	2	<b>9</b>
<i>Capital costs</i>	11	6	21	7	10	8	<b>8</b>
<i>O&amp;M costs</i>	15	24	18	24	27	17	<b>24</b>
<i>Discounted payback period</i>	1	15	15	8	17	4	<b>6</b>
<i>Support schemes</i>	20	3	14	5	7	1	<b>5</b>
<i>Job creation</i>	4	12	8	3	2	3	<b>4</b>
<i>Social acceptability</i>	2	9	1	1	5	24	<b>2</b>
<i>Land use</i>	25	26	23	27	8	18	<b>26</b>
<i>Noise</i>	16	28	22	28	9	25	<b>28</b>
<i>Avoided CO<sub>2</sub> emissions</i>	8	19	9	22	6	6	<b>17</b>
<i>Protected areas</i>	12	18	10	23	4	9	<b>18</b>
<i>Potential seismicity</i>	13	13	7	14	1	5	<b>7</b>
<i>Conflict with other subsurface uses</i>	22	25	13	25	3	10	<b>23</b>

Once the global weights of each element in the sub-criteria level were calculated for each stakeholder's group the final grade of each scenario and for each site was calculated. The obtained results and comparison between each stakeholder's group is shown Figure 5.25.

If the methodology is used to compare two geothermal sites for the same scenario, the results show that for all stakeholder groups Site 2 is the better option, i.e., optimal for the developed case study (Table 5.66). More differences are observed in final results for the comparison of different scenarios for both geothermal sites. Namely, for Site 1 stakeholder groups industry, educational institution, and other assessed the 'Scenario Electricity' as a better option. Stakeholder groups RTO, SME and local community assessed the 'Scenario Heat' as better option for the Site 1. For Site 2, all stakeholder groups assessed the 'Scenario Heat' to be the better option.

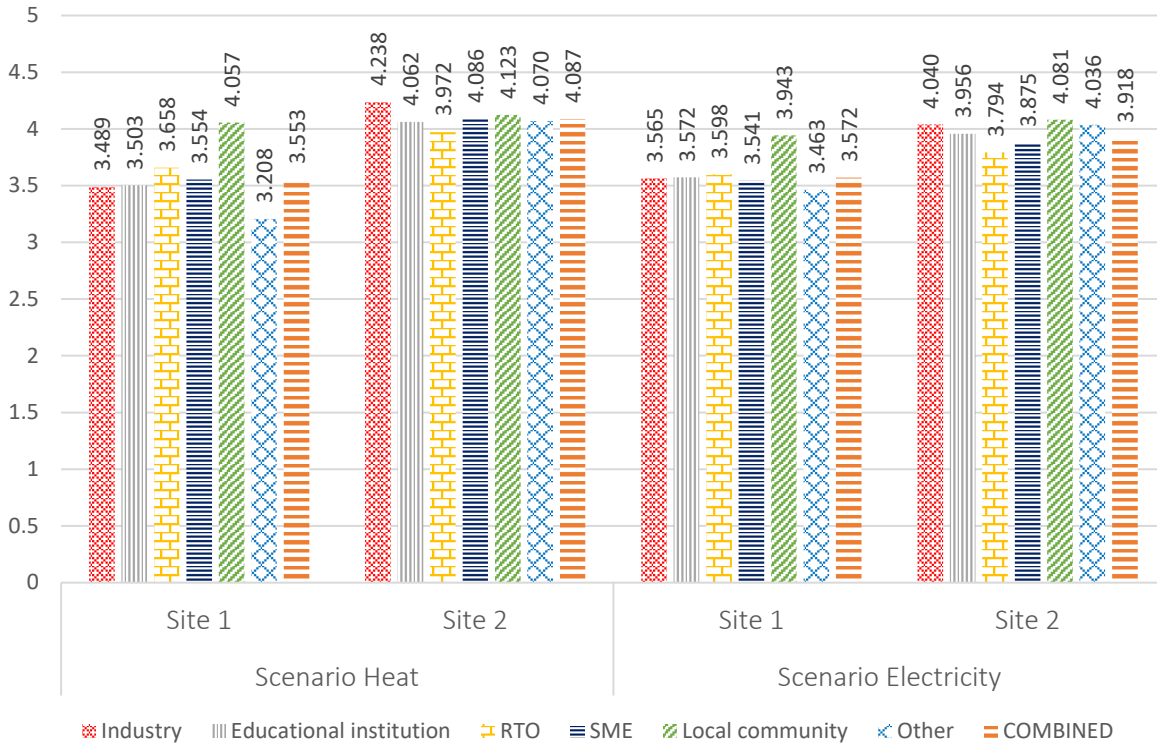

Figure 5.25. Finale grades for each stakeholder's group for 'Scenario Heat' and 'Scenario Electricity' for both sites

Table 5.66. Results for: i) comparison of geothermal sites for the same scenario and ii) comparison of different scenarios at the same geothermal site (for each stakeholder's group and combined)

	Scenario Heat	Scenario Electricity	Site 1	Site 2
Industry	Site 2	Site 2	Scenario Electricity	Scenario Heat
Educational institution	Site 2	Site 2	Scenario Electricity	Scenario Heat
RTO	Site 2	Site 2	Scenario Heat	Scenario Heat
SME	Site 2	Site 2	Scenario Heat	Scenario Heat
Local community	Site 2	Site 2	Scenario Heat	Scenario Heat
Other	Site 2	Site 2	Scenario Electricity	Scenario Heat
COMBINED	Site 2	Site 2	Scenario Electricity	Scenario Heat

#### 5.4.1.4.4. Detailed analysis by expertise background of respondents

Apart from different point of view depending on the stakeholder's group, a professional background of each involved actor also influences their preferences. The preferences are not only influenced by the development strategy and goals of the organizations where the respondents are employed at, but a significant part of the decision and preferences is influenced the level of the geological background and expertise of the respondent. Therefore, in this Section, the results of the groups with geological background (expertise) and without geological background are analysed. The group with geological background consists of geologists, geophysics, rock physics, hydrogeologists, reservoir engineers, geoscientists, and petroleum engineers. Participants of this group are not all strictly related to geology, however, all of them have some knowledge about geology related topics. In the group without geological background belong material engineers, project managers, power system engineers, process engineers, heat engineers, energy traders and planners, electrical engineers, and site engineers including RES project developers.

When analysing the criteria level, both groups associated similar importance to the criteria groups: geological setting criteria in the first place, followed by economy/finance criteria, technology criteria, environment, and society at the last place (Table 5.67). However, when analysing the weights themselves, the differences can be noted (Figure 5.26). Namely, group with geological background assigned weights of 33.63%, and 20.94%, and the group without geological background 28.86% and 27.14% to geological setting criteria and to economic/finance criteria, respectively. Additionally, considering most of the respondents from the group with no geological background are process, mechanical or power system engineers, this group assigned higher weight to technology criteria (19.28%) compared to the group with geological background (17.27%).

Figure 5.27. depicts the comparison of the results of the sub-criteria level for both groups. It can be observed that the group with geological background assigned higher importance to most of the geological criteria, compared to the group with no geological background. For the group with geological background, the most important sub-criterion is permeability (7.88%). In contrast, for the group without geological background, the support scheme sub-criterion was assigned with the highest relative importance (7.36%). This sub-criterion showed also the biggest divergence in assigned weights for the two groups, because the group with geological background assigned the importance of 3.66%.



Table 5.67. Ranking for the criteria level for each group of different background

	Geological background	No geological background
Geological setting	1	1
Technology	3	3
Economy/Finance	2	2
Society	5	5
Environment	4	4

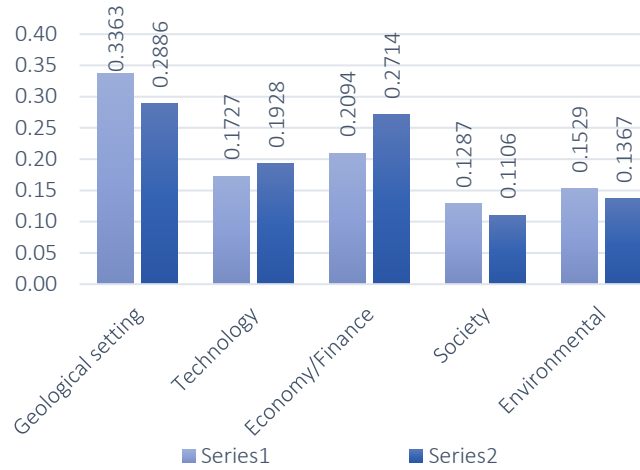

Figure 5.26. Analysis results for the first level for each group (with and with no geological background)

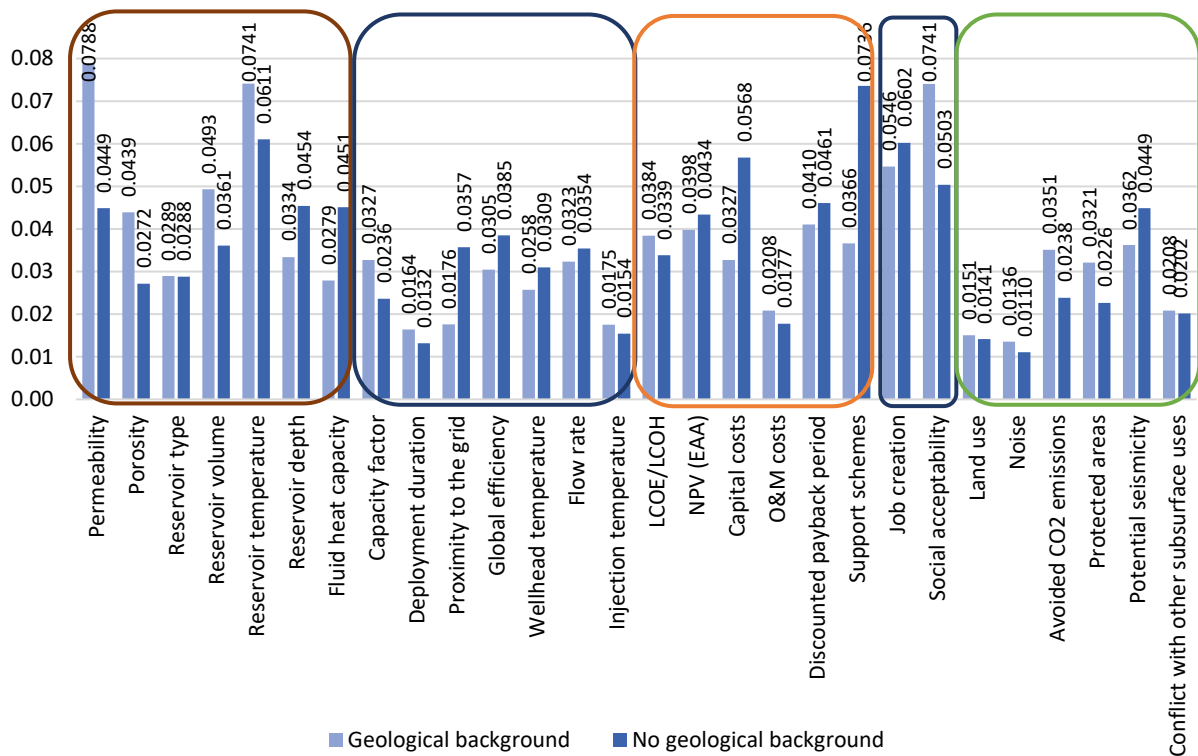

Figure 5.27. Results for the sub-criteria level - global weights for both groups (colour of rectangle is correspondent to the following group of criteria: brown – geological setting criteria; blue – technology criteria; orange – economic criteria; dark blue – social criteria; green – environmental criteria)

The ranking of the criteria in the sub-criteria level is shown in Table 5.68. It can be observed that the most dominant sub-criteria differ for both groups with permeability being the most dominant sub-criterion for the group with geological background and support schemes for the group without geological background. Considering that most of the experts in the group without geological background are to some extent involved in renewable energy projects development, it is clear that some sort of financial support for such projects, especially at the initial stages is of biggest importance from their perspective and experience. The consensus about the ranking of the sub-criteria is achieved for reservoir temperature, which was ranked

second for both groups, and for sub-criteria placed in the last third of the ranking such as reservoir type, deployment duration, O&M costs, land use, noise, and conflict with other subsurface usages sub-criteria.

Detailed results for each criteria level group and each group are shown in graphs in Appendix A (Figure A.6–Figure A.10). The graphs in Appendix A showing the local weights of sub-criteria from the perspective of each group.

Table 5.68. Ranking for the sub-criteria level (according to global weights) for group and combined results (all respondents as one group) (for comparison)

	<b>Geological background</b>	<b>No geological background</b>	<b>COMBINED RESULTS</b>
<i>Permeability</i>	1	9	3
<i>Porosity</i>	6	19	12
<i>Reservoir type</i>	19	18	20
<i>Reservoir volume</i>	5	13	10
<i>Reservoir temperature</i>	2	2	1
<i>Reservoir depth</i>	13	7	11
<i>Fluid heat capacity</i>	20	8	14
<i>Capacity factor</i>	14	21	19
<i>Deployment duration</i>	26	27	27
<i>Proximity to the grid</i>	24	14	22
<i>Global efficiency</i>	18	12	15
<i>Wellhead temperature</i>	21	17	21
<i>Flow rate</i>	16	15	16
<i>Injection temperature</i>	25	25	25
<i>LCOE/LCOH</i>	9	16	13
<i>NPV (EAA)</i>	8	11	9
<i>Capital costs</i>	15	4	8
<i>O&amp;M costs</i>	23	24	24
<i>Discounted payback period</i>	7	6	6
<i>Support schemes</i>	10	1	5
<i>Job creation</i>	4	3	4
<i>Social acceptability</i>	3	5	2
<i>Land use</i>	27	26	26
<i>Noise</i>	28	28	28
<i>Avoided CO<sub>2</sub> emissions</i>	12	20	17
<i>Protected areas</i>	17	22	18
<i>Potential seismicity</i>	11	10	7
<i>Conflict with other subsurface uses</i>	22	23	23

Once the global weights of each element in the sub-criteria level were calculated for both groups, the final grade of each scenario and for each site was calculated. The obtained results and comparison between each stakeholder’s group is shown Figure 5.28.

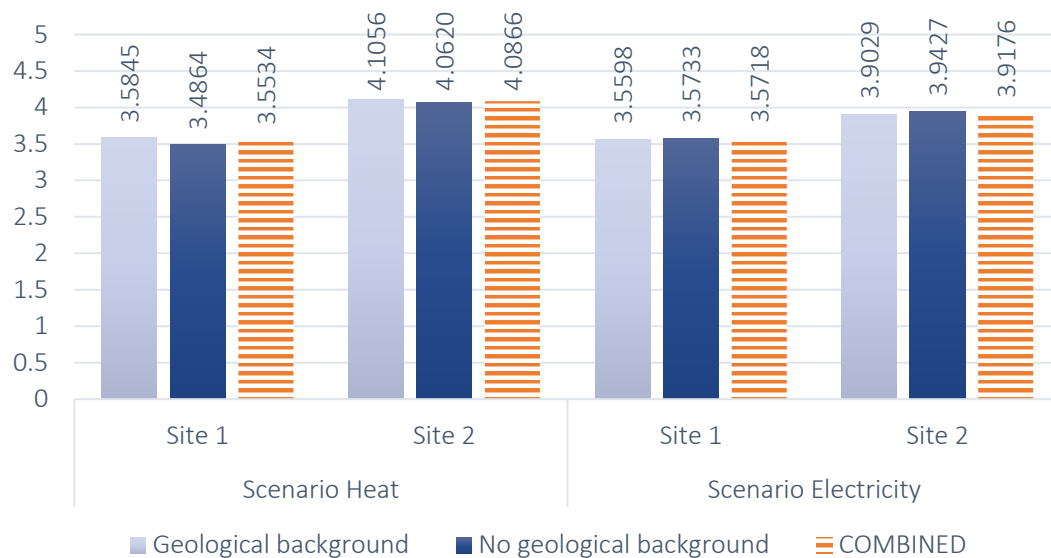

Figure 5.28. Finale grades for each group for 'Scenario Heat' and 'Scenario Power' for both sites

If the methodology is used to compare two geothermal sites for the same scenario, the results show that for both groups Site 2 is the better option, i.e., optimal for the developed case study (Table 5.69). For the comparison of different scenarios for both geothermal sites the group with geological background assessed the 'Scenario Heat' as a better option for Site 1. The group without geological background assessed the 'Scenario Electricity' as a better option for the Site 1. For Site 2, both groups assessed the 'Scenario Heat' to be the better option.

Table 5.69. Results for: i) comparison of geothermal sites for the same scenario and ii) comparison of different scenarios at the same geothermal site (for both groups and combined)

	Scenario Heat	Scenario Electricity	Site 1	Site 2
Geological background	Site 2	Site 2	Scenario Heat	Scenario Heat
No geological background	Site 2	Site 2	Scenario Electricity	Scenario Heat
COMBINED	Site 2	Site 2	Scenario Electricity	Scenario Heat

#### 5.4.2. Ranking method – VIKOR

In the decision-making process, the decision maker tends to choose the alternative that satisfies the best all criteria assumed to have an influence on the decision. Generally, to achieve such goal is hard, therefore a sound compromise solution needs to be found. In this regard, the Multi-Criteria Optimization and Compromise Solution (*VIšekriterijumska Optimizacija I Kompromisno Rešenje*, VIKOR) was developed for multi-criteria optimization of complex systems [110].

VIKOR method is based on the compromise programming of MDCM, and it was introduced as a technique applicable within multi attribute decision-making (MADM). It was developed to solve MCDM problems with non-commensurable (different units) and

conflicting criteria, presenting the compromise solution which can help DM to reach a final decision. The compromise solution is a feasible solution that is closest to the ideal, and compromise means an agreement established by mutual concession [111]. The obtained optimized solution provides the maximum group utility of the majority and the minimum individual regret of the opponent.

Namely, the VIKOR method was developed to solve the following problem:

$$mco_j\{(f_{ij}(A_j), j = 1, \dots, J), i = 1, \dots, n\}, \quad (5.40)$$

where  $J$  is the number of feasible alternatives,  $A_j = \{x_1, x_2, \dots, x_n\}$  is the  $j^{th}$  alternative obtained with certain values of system variables  $x$ ,  $f_{ij}$  is the value of  $i^{th}$  criterion function for the alternative  $A_j$ ,  $n$  denotes the number of criteria, and  $mco$  denotes the operator of multi-criteria decision-making process for selecting the best (compromise) alternative in multi-criteria sense.

#### 5.4.2.1. Background of VIKOR method

Generally, the VIKOR method is based on the multicriteria measure for compromise ranking developed from the  $L_p$ -metric (Equation 5.41) which is used in the compromise programming method [290], [291].

$$L_{p,j} = \left\{ \sum_{i=1}^n [w_i(f_i^* - f_{ij}) / (f_i^* - f_i^-)]^p \right\}^{1/p} \quad (5.41)$$

$$1 \leq p \leq \infty ; j = 1, 2, \dots, J, \quad (5.42)$$

where  $f_i^*$  represents the best and  $f_i^-$  the worst values of all criterion functions,  $i = 1, 2, \dots, n$ . Within the VIKOR method the  $L_{1,j}$  (Equation 5.43) and  $L_{\infty,j}$  (Equation 5.44) are used to formulate ranking measure. The solution obtained by  $\min_j S_j$  is with a maximum group utility (“majority” rule), and the solution obtained by  $\min_j R_j$  is with a minimum individual regret of the “opponent” [259].

The compromise solution  $F^c$  is a feasible solution that is the “closest” to the ideal solution  $F^*$ , and compromise is an agreement established by mutual concessions represented by  $\Delta f_i = f_i^* - f_i^c$ , for  $i = 1, 2, \dots, n$  (as illustrated in Figure 5.29 for  $n = 2$ ).

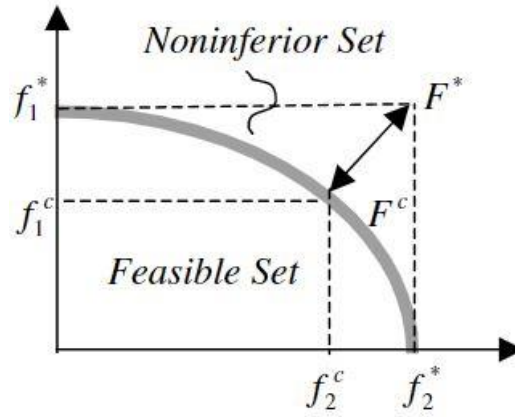

Figure 5.29. Ideal and compromise solutions (source: [259])

#### 5.4.2.2. VIKOR method workflow

The compromise ranking algorithm VIKOR consists of following steps:

1. Determining the best  $f_i^*$  and worst  $f_i^-$  values of all criteria,  $i = 1, 2, \dots, n$ .

$$f_i^* = \max_j f_{ij}, \quad f_i^- = \min_j f_{ij} \quad \text{if the } i^{\text{th}} \text{ function represents a benefit;}$$

$$f_i^* = \min_j f_{ij}, \quad f_i^- = \max_j f_{ij} \quad \text{if the } i^{\text{th}} \text{ function represents a cost.}$$

2. Computing the values  $L_{1,j}$  and  $L_{\infty,j}$  which are usually noted as  $S_j$  and  $R_j$ , respectively. Where  $j = 1, 2, \dots, J$ . In following equations  $w_i$  are the weights of criteria, expressing the decision maker's preference as the relative importance of each criterion.

$$S_j = \sum_{i=1}^n w_i (f_i^* - f_{ij}) / (f_i^* - f_i^-) \quad (5.43)$$

$$R_j = \max_i [w_i (f_i^* - f_{ij}) / (f_i^* - f_i^-)] , \quad (5.44)$$

where  $S_j$  is the alternative with respect to all criteria calculated by the sum of the distance for best value, and  $R_j$  is the alternative with respect to  $i^{\text{th}}$  criterion, calculated by the maximum distance from the worst value. The linear normalization is used in VIKOR method as implied in Equations (5.43) and (5.44).

3. Computing the values  $Q_j$ ,  $j = 1, 2, \dots, J$  by the following equations:

$$Q_j = v \cdot \frac{(S_j - S^*)}{(S^- - S^*)} + (1 - v) \cdot \frac{(R_j - R^*)}{(R^- - R^*)} \quad (5.45)$$

$$S^* = \min_j S_j, S^- = \max_j S_j \quad (5.46)$$

$$R^* = \min_j R_j, R^- = \max_j R_j \quad (5.47)$$

In Equation (5.45) the parameter  $\nu$  is introduced as weight of the strategy of “the majority of criteria” (in other words as “the maximum group utility”), whereas  $(1 - \nu)$  is the weight of the individual regret. Usually the value of  $\nu$  is taken as 0.5, however, it can be any value from 0 to 1 [292]. The  $S^*$  is the minimum value of  $S_j$  which is the maximum group utility and  $R^*$  is the minimum value of  $R_j$  which is the minimum individual regret of the opponent.

4. Ranking the alternatives, sorting by the values  $S$ ,  $R$ , and  $Q$  in decreasing order.
5. Proposing as a compromise solution the alternative  $A'$  which is ranked the best by the index  $Q$  (minimum value) if the following two conditions are satisfied [111]:

**C1. “Acceptance advantage”** holds whenever:

$$Q(A'') - Q(A') \geq DQ \quad (5.48)$$

$$DQ = \frac{1}{J-1}, \quad (5.49)$$

where  $A''$  is the second position in the ranking list obtained,  $J$  is the number of alternatives. Additionally,  $DQ = 0.25$  if  $J \leq 4$ .

**C2. “Acceptance stability in decision making”:** Alternative  $A'$  must also be the best ranked by  $S$  or/and  $R$ . This compromise solution is stable within a decision-making process, which could be: “voting by majority rule” (when  $\nu > 0.5$  is needed), or “by consensus” (when  $\nu \approx 0.5$ ), or “with vet0” (when  $\nu < 0.5$ ).

If case when one of the conditions is not satisfied, a set of compromise solutions is proposed which consists of:

- Alternatives  $A'$  and  $A''$  if only condition C2 is not satisfied, i.e., it is deficient.
- Alternatives  $A', A'', \dots, A^{(M)}$  if condition C1 is not satisfied and  $A^{(M)}$  is determined by the relation  $Q(A^{(M)}) - Q(A') < DQ$  for the maximum  $M$  (position of these alternatives are ‘in closeness’).

#### 5.4.2.3. Case study

After determining the evaluation criteria (Section 5.2.2) and the standardized grading of each criterion (Section 5.3.1) and implementing the AHP method for criteria weighting (Section

5.4.1.4), the final step of the integrated MCDM methodology can be performed. Namely, the VIKOR method is implemented to rank the possible alternatives. The alternatives are electricity generation and heat production.

The first step of VIKOR part of integrated methodology is to create a matrix containing the values of each criterion for each alternative:

$$\mathbf{R} = \begin{bmatrix} r_{1,1} & r_{1,2} & \cdots & r_{1,n} \\ r_{2,1} & \cdots & \cdots & r_{2,n} \\ \vdots & \vdots & \ddots & \vdots \\ r_{m,1} & r_{m,2} & \cdots & r_{m,n} \end{bmatrix} \quad i = 1, 2, \dots, m ; j = 1, 2, \dots, n \quad , \quad (5.50)$$

where  $r_{i,j}$  is the value of criterion  $j$  for the alternative  $A_i$ . For criteria that is assessed in Section 5.3.1 as a combination of sub-factors the finale grades of the performance value  $x_{i,j}$  are considered as value  $r_{i,j}$ . Additionally, if the criterion is qualitative one, i.e., the performance is assessed by means of linguistic terms, the grade for performance value  $x_{i,j}$  is considered as value  $r_{i,j}$ . For all other criteria, the value  $r_{i,j}$  is either measured real data or calculated data.

The matrix is then normalized using the linear additive method (i.e. sum method) [293]–[295]:

$$f_{i,j} = \frac{r_{i,j}}{\sum_i r_{i,j}} \quad (5.51)$$

The second step is to determine the best  $f_j^*$  and worst  $f_j^-$  values of each criterion. Certain criteria are categorized as beneficial criteria, while others are considered non-beneficial criteria (Table 5.70). This classification implies that, for beneficial criteria, a higher value is indicative of a better outcome, whereas, for non-beneficial criteria, a lower value signifies a more favourable outcome. Consequently, the calculations for  $f_j^*$  and  $f_j^-$  differ for beneficial criteria, as demonstrated in Equation (5.52), and for non-beneficial criteria, as illustrated in Equation (5.53), in accordance with the definitions provided in Section 5.4.2.2:

$$f_j^* = \max_i f_{i,j} \quad \text{and} \quad f_j^- = \min_i f_{i,j} \quad (5.52)$$

$$f_j^* = \min_i f_{i,j} \quad \text{and} \quad f_j^- = \max_i f_{i,j} \quad (5.53)$$

Next the  $S_i$  and  $R_i$  are computed according to Equations (5.54) and (5.55) which are in this developed integrated MCDM methodology slightly modified. Namely, the  $S_i$  and  $R_i$  are calculated as follows:

$$S_i = \sum_{j=1}^n \tilde{w}_j (f_j^* - f_{ij}) / (f_j^* - f_j^-) \quad (5.54)$$

$$R_i = \max_j [\tilde{w}_j (f_j^* - f_{ij}) / (f_j^* - f_j^-)] , \quad (5.55)$$

where  $\tilde{w}_j$  denotes the graded weight of criterion  $j$ ,  $j \in J$ ,  $J$  represents a cumulative number of criterions. The graded weight is obtained as following:

$$\tilde{w}_j = x_{ij} \cdot w_j ; i \in I \quad (5.56)$$

$$x_{ij} \in \{1, 2, 3, 4, 5\} , \quad (5.57)$$

where the  $w_j$  denotes the importance weight of each criterion  $j$  in the decision process obtained with AHP, and  $x_{ij}$  the numerical grade of alternative  $i$  on criterion  $j$ ,  $I$  is a cumulative number of options being evaluated and compared.

In the next step  $S^*$ ,  $S^-$ ,  $R^*$ ,  $R^-$ , and  $Q_i$  are calculated according to Equations (5.45) – (5.47). For the calculations, the value of  $\nu$  is 0.5, meaning that the decision-making process is by consensus. Finally, the best alternative with the minimum  $Q_i$  is determined.

The VIKOR method, as a part of the integrated MCDM methodology, was employed using the identical dataset detailed in Section 5.3.2, specifically encompassing data presented in Table 5.48 and Table 5.50. This application of the integrated MCDM methodology aimed to evaluate and juxtapose two distinct scenarios for both sites, focusing on heat production and electricity generation scenarios for each respective site.

Table 5.70. Type of criteria for VIKOR method

Parameter	Criterion type	Parameter	Criterion type
Permeability	beneficial	LCOE/LCOH	non-beneficial
Porosity	beneficial	NPV (EAA)	beneficial
Reservoir type	beneficial	Capital cost	non-beneficial
Reservoir volume	beneficial	O&M cost	non-beneficial
Reservoir temperature	beneficial	Discounted payback period	non-beneficial
Reservoir depth	beneficial	Support schemes	beneficial
Fluid specific heat capacity	beneficial	Job creation	beneficial
Capacity factor	beneficial	Social acceptability	beneficial
Deployment duration	non-beneficial	Land use	non-beneficial
Proximity to the grid	beneficial	Noise	non-beneficial
Global efficiency	beneficial	Avoided CO2 emissions	beneficial
Wellhead temperature	beneficial	Protected area	beneficial
Flow rate	beneficial	Potential seismicity	beneficial
Injection temperature	beneficial	Conflict with other subsurface uses	beneficial



#### 5.4.2.3.1. Results

Four alternatives were compared: ‘Scenario Electricity’ for Site 1, ‘Scenario Heat’ for Site 1, ‘Scenario Electricity’ for Site 2, and ‘Scenario Heat’ for Site 2. Based on this, the matrix  $\mathbf{R}$  was built according to Equation (5.50) was built. The matrix was then normalized and the best  $f_j^*$  and worst  $f_j^-$  values of each criterion were determined. Based on those values,  $S_i$  and  $R_i$  were computed and lastly  $S^*$ ,  $S^-$ ,  $R^*$ ,  $R^-$  were calculated. For the graded weights,  $\tilde{w}_j$ , the weights obtained in Section 5.4.1.4.2 were used, where geometric mean of all 35 participants was used to calculate the weights of each criterion.

The results of ranking of those alternatives are shown in Table 5.71 and Table 5.72.

Table 5.71.  $S^*$ ,  $S^-$ ,  $R^*$  and  $R^-$  values for all respondents as one group

$S^*$	0.7834
$S^-$	1.1923
$R^*$	0.1429
$R^-$	0.3320

Table 5.72. Results of integrated MCDM methodology analysis

		$S_i$	$R_i$	$Q_i$
Scenario Electricity	<b>Site 1</b>	1.1141	0.2082	<b>0.5771</b>
	<b>Site 2</b>	1.1923	0.3320	<b>1.0000</b>
Scenario Heat	<b>Site 1</b>	0.8727	0.1429	<b>0.1092</b>
	<b>Site 2</b>	0.7834	0.3320	<b>0.5000</b>

To obtain the final ranking the conditions C1 (Acceptance advantage) and C2 (Acceptance stability) need to be verified and satisfied so that the final ranking and compromise solution can be obtained. In this analysis both conditions were satisfied. Therefore, the final ranking of the alternatives, when analysis all 35 respondents as one group are shown in Table 5.73.

Table 5.73. Final ranking of alternatives for all respondents as one group

<b>Alternative</b>	<b>Ranking</b>
Scenario Heat – Site 1	1
Scenario Heat – Site 2	2
Scenario Electricity - Site 1	3
Scenario Electricity – Site 2	4

Additionally, when results obtained with integrated MCDM methodology are compared with results obtained in Section 5.3.2 (final grade and ranking obtained based on average of

grades of criteria) and Section 5.4.1.4.2 (finale grade and ranking obtained based on AHP-WSM method) it is observed that the final rankings differ (Figure 5.30). It can be concluded that integrated MCDM methodology takes into account not only graded weights which reflects the subjectivity of decision-makers in the decision-making process, but also objective evaluation of each criterion for each alternative, because it finds the compromise solution which is closest to ideal for analysed set of alternatives. The obtained solution, i.e. ranking could be accepted by the decision-makers because it provides a maximum group utility of the majority and a minimum individual regret of the opponent. However, since part of the integrated MCDM methodology is VIKOR method, it must be pointed out that the results depend on the ideal solution which stands only for the given set of alternatives. Should any alternatives be included or excluded from the analysis, that could affect the ranking of alternatives. This effect could potentially be avoided if the best  $f_j^*$  and the worst  $f_j^-$  values are defined, however, that would mean that a fixed ideal solution could be defined by the decision-maker which is rarely the case.

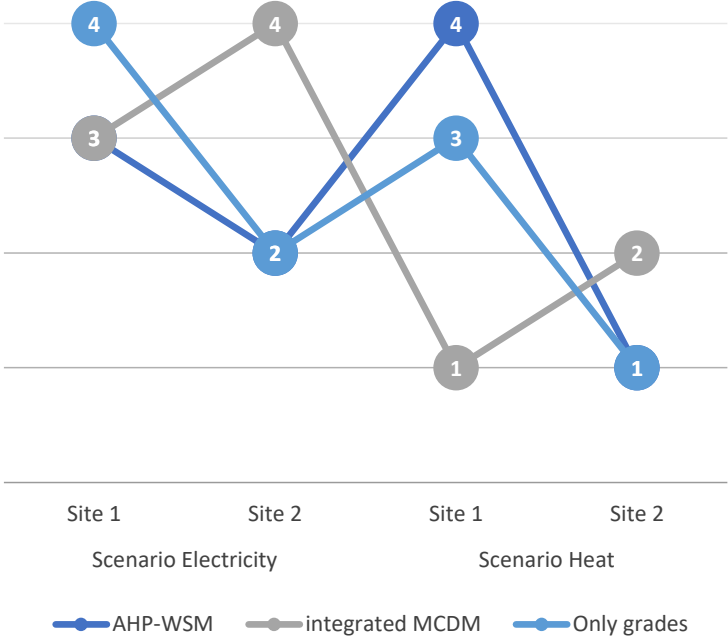

Figure 5.30. Comparison of alternatives' ranking for all stages of case study

5.4.2.3.2. Detailed analysis of results by stakeholder group

Detailed analysis of results by stakeholder group was done based on the weights obtained and presented in Section 5.4.1.4.3. The results of obtained results of  $S_i$ ,  $R_i$ , and  $Q_i$  for each stakeholder group are shown in Table 5.74. The conditions C1 and C2 were satisfied for industry, educational institutions, RTO, SME, and local community stakeholder groups, for others, the condition C1 was not satisfied. Therefore, final ranking results for others

stakeholder group is a compromise solution consisting of first three alternatives for which  $Q(A^{(M)}) - Q(A') < DQ$  is attained, where  $DQ$  is 0.25. The final rankings of alternative for each stakeholder group are shown in Figure 5.31. It can be observed that alternative ‘Scenario Heat’ Site 1 is ranked as the best alternative for all stakeholder groups, except others stakeholder group. Furthermore, ‘Scenario Electricity’ for Site 2 is the last ranked alternative for all stakeholder groups except local community stakeholder group. Additionally, the alternative ‘Scenario Electricity’ for Site 1 shows most diversity in final ranking place among stakeholder groups.

Table 5.74. Results of integrated MCDM methodology analysis for each stakeholder group

			$S_i$	$R_i$	$Q_i$
<i>Industry</i>	Scenario Electricity	<b>Site 1</b>	1.2185	0.2208	<b>0.7192</b>
		<b>Site 2</b>	1.3306	0.2514	<b>1.0000</b>
	Scenario Heat	<b>Site 1</b>	0.8471	0.1717	<b>0.1158</b>
		<b>Site 2</b>	0.7015	0.2514	<b>0.5000</b>
<i>Educational institutions</i>	Scenario Electricity	<b>Site 1</b>	0.8331	0.2091	<b>0.2243</b>
		<b>Site 2</b>	1.4199	0.5114	<b>1.0000</b>
	Scenario Heat	<b>Site 1</b>	0.6634	0.1217	<b>0.0000</b>
		<b>Site 2</b>	1.0706	0.5114	<b>0.7691</b>
<i>RTO</i>	Scenario Electricity	<b>Site 1</b>	0.7361	0.1381	<b>0.2692</b>
		<b>Site 2</b>	0.9219	0.2662	<b>1.0000</b>
	Scenario Heat	<b>Site 1</b>	0.5744	0.1280	<b>0.0000</b>
		<b>Site 2</b>	0.6232	0.2662	<b>0.5702</b>
<i>SME</i>	Scenario Electricity	<b>Site 1</b>	0.9905	0.2233	<b>0.3350</b>
		<b>Site 2</b>	1.3653	0.3134	<b>1.0000</b>
	Scenario Heat	<b>Site 1</b>	0.8061	0.1769	<b>0.0000</b>
		<b>Site 2</b>	0.9668	0.3134	<b>0.6437</b>
<i>Local community</i>	Scenario Electricity	<b>Site 1</b>	1.1380	0.4743	<b>1.0000</b>
		<b>Site 2</b>	0.9941	0.4743	<b>0.8807</b>
	Scenario Heat	<b>Site 1</b>	0.5352	0.1701	<b>0.0000</b>
		<b>Site 2</b>	0.8059	0.4743	<b>0.7245</b>
<i>Others</i>	Scenario Electricity	<b>Site 1</b>	1.0649	0.2262	<b>0.1403</b>
		<b>Site 2</b>	1.4632	0.3650	<b>1.0000</b>
	Scenario Heat	<b>Site 1</b>	0.9095	0.2937	<b>0.2431</b>
		<b>Site 2</b>	0.9769	0.2937	<b>0.3040</b>

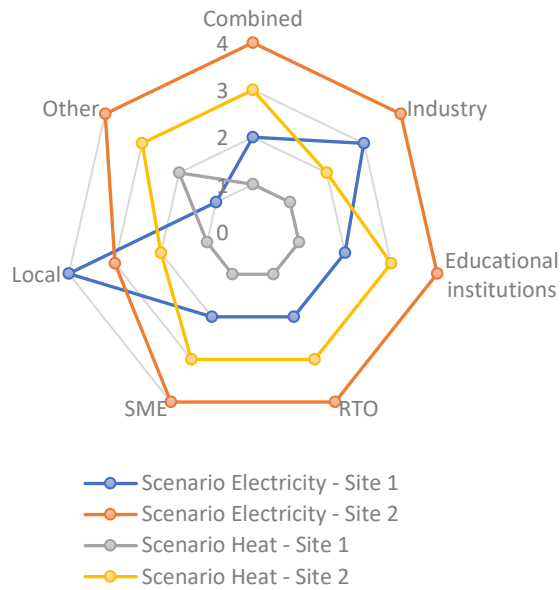

Figure 5.31. Final ranking of alternatives for each stakeholder group and for all respondents as one group (depicted as 'combined')

#### 5.4.3.2.3. Detailed analysis of results by expertise background of respondents

Detailed analysis of results by expertise background of respondents was done based on the weights obtained and presented in Section 5.4.1.4.4. The results of obtained results of  $S_i$ ,  $R_i$ , and  $Q_i$  for each stakeholder group are shown in Table 5.75. The conditions C1 and C2 were satisfied for the group with no geological background, however, for the group with geological background C1 was not satisfied. Therefore, final ranking results for group with geological background is a compromise solution consisting of first two alternatives for which  $Q(A^{(M)}) - Q(A') < DQ$  is attained, where  $DQ$  is 0.25. The final rankings of alternative for each stakeholder group are shown in Figure 5.32. It can be observed that 'Scenario Electricity' for Site 2 is evaluated as least favourable alternative for all groups, and 'Scenario Heat' for Site 1 as the best alternative for all groups.

Table 5.75. Results of integrated MCDM methodology analysis for each stakeholder group

			$S_i$	$R_i$	$Q_i$
<i>Geological background</i>	Scenario Electricity	<b>Site 1</b>	0.9070	0.1639	<b>0.1622</b>
		<b>Site 2</b>	1.2940	0.3704	<b>1.0000</b>
	Scenario Heat	<b>Site 1</b>	0.7220	0.1637	<b>0.0000</b>
		<b>Site 2</b>	0.8770	0.3704	<b>0.6355</b>
<i>No geological background</i>	Scenario Electricity	<b>Site 1</b>	1.0518	0.2838	<b>0.6642</b>
		<b>Site 2</b>	1.3831	0.3053	<b>1.0000</b>
	Scenario Heat	<b>Site 1</b>	0.7646	0.1472	<b>0.0000</b>
		<b>Site 2</b>	0.9792	0.3053	<b>0.6735</b>

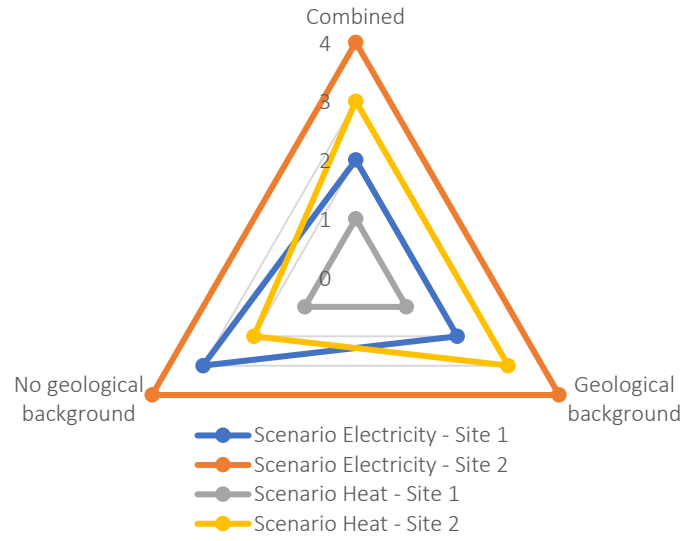

Figure 5.32. Final ranking of alternatives both groups and for all respondents as one group (depicted as 'combined')



## EVALUATION MODEL

THIS CHAPTER provides an overview of the evaluation model developed for the assessment of Enhanced Geothermal System (EGS) energy projects. The model is designed to facilitate the comparison of various scenarios for EGS projects, including different utilization options of geothermal energy at specific geothermal site and comparisons between different geothermal sites for the same utilization option. The chapter outlines the process of developing the model, the modelling approach employed, and offers detailed descriptions of the components that constitute the evaluation model. Additionally, the chapter introduces a decision-support tool, presented as a standalone application with a user-friendly graphical user interface. The evaluation model and decision-support tool have been validated and verified using real datasets and existing power plants in operation. Furthermore, the model has been applied to compare various geothermal energy utilization options at specific sites and to assess different geothermal sites for the same utilization option. The results obtained from these analyses are presented within this chapter.

### 6.1. PREAMBLE

As seen in Chapter 3 there are several existing models and evaluation software packages for techno-economic assessment of geothermal energy projects. The models differ in the level of detail in calculations, but also in number and type of input parameters used for the calculations and consequently obtained output parameters. It can be observed that the parameters and processes related to the subsurface are more extensively modelled and included in the calculations, while surface technical parameters are less detailed. Additionally, no reviewed tool has in no way assessed the societal and environmental impact of such projects which can in some cases present a significant barrier. Namely, apart from being capital-intensive projects which imposes some barriers to higher market penetration, the geothermal projects and especially EGS projects are related to different socio-environmental impacts such as water usage and potential water contamination, potential induced seismicity caused by simulation techniques during exploration and drilling phases or caused by the circulation of the geothermal fluid during the operational phase. Even though large magnitude

events are rare, the induced seismicity has been the cause of delays and threatened cancellation of at least couple of EGS projects worldwide. Namely, thousands of seismic events are generated annually in Europe during exploitation of geothermal fields, but in most cases these events are below local magnitude  $M_L = 2$ , and below the detection threshold of communities [252]. However, some geothermal sites have experienced  $M_L > 2.5$  due to EGS activities such as Cooper Basin in Australia, Basel in Switzerland, Soultz-sous-Forêts in France, Berlin, El Salvador, etc [251]. Closely associated to this environmental impact problem of induced seismicity is also societal acceptance of EGS projects. Namely, geothermal projects have high impact on local community since the energy facilities are located close to the end-users (especially in case of heat production) due to connection costs. Therefore, the perception of benefits of investment in such energy facility must be higher than the 'negative' impacts which may occur.

Additionally, apart from socio-environmental aspects which assessments are rather neglected in reviewed existing models, tools and software packages, the financial aspect in terms of different support schemes is also not included. However, the benefits of different applicable support schemes for EGS projects, depending on the country-defined regulations, should be assessed because this could either support the development and investment in such project or reject the potential option.

Furthermore, as mentioned in Chapter 3, only GEOPHIRES software can simulate and assess all three possible geothermal energy utilization options (electricity generation, heat production, and CHP). However, this is one of the essential features of such evaluation model, because by modelling all mentioned types of geothermal energy utilization the potential investor, i.e., decision-maker can assess every possible option for a specific site reaching in the end the best solution.

Aforementioned state of the art was a motivation for development of an evaluation model which will to certain extent be able to assess main influencing factors from all five main aspects (geological setting, technology, economy/finance, society, and environment) as shown in Chapter 5, Section 5.1.2. (Figure 5.1).

The developed evaluation model utilizes comprehensive and detailed techno-economic analysis and is significantly more holistic in nature compared to existing models and approaches. In that sense, besides technical and economic aspects it takes into account also the most relevant environmental and societal aspects. In addition, as it was clearly stressed out in Chapter 5, since assessing a geothermal energy project, especially EGS project, is a very complex process and often requires vast knowledge in many different fields, the MCDM



method can facilitate the whole decision-making process. Therefore, along with the ‘classical’ techno-economic assessment of EGS project, the developed evaluation model uses additional feature which consists of integrated MCDM methodology (described in Chapter 5, Section 5.3 and Section 5.4). This feature can be used to translate the raw economic and performance data into a decision, i.e., based on the outcomes of applying MCDM methodology for a specific scenario, the best (optimal) solution can be chosen by the decision-maker.

## 6.2. DEVELOPMENT PROCESS

The main motivation when developing the evaluation model was to provide a model that is to be sufficiently technical to be helpful for experts with certain amount of knowledge, expertise and experience (e.g., industry professionals) and also to ordinary users with little or no experience and knowledge (e.g. local community). Additionally, to cover large number of potential projects the developed model can be used for both greenfield and brownfield projects. Namely, it can be used to evaluate yet undeveloped geothermal projects based on assumptions and different scenarios, and consequently generate valuable datasets, i.e. suggestions that can serve as a basis for more detailed site investigation. On the other hand, the evaluation model can be applied to assessment of potential EGS sites with already existing, estimated input data and measured data during the year-long operation of existing infrastructure. Such sites are already existing EGS sites which seek for and upgrade or extension of existing infrastructure or mature and abandoned oil fields that are foreseen to be converted in geothermal fields. It must be noted that, depending on whether the project of interest is greenfield or brownfield, the level of assessment reliability will vary. Namely, the input parameters for a brownfield project are more reliable and accurate and many input parameters for a greenfield project are more uncertain and thus less reliable.

### 6.2.1. Approach and concept for evaluation model development

The developed evaluation model is a MATLAB-based tool that calculates important performance and economic indices for various possible scenarios, provides multi-criteria decision-making analysis by means of developed integrated MCDM methodology and thereby eases the decision-making process. MATLAB software is described in some more detail in Section 6.2.2. The modelling and development in MATLAB software, among other important features listed in Section 6.2.2, enabled a provision of user-friendly and straightforward graphical user interface (GUI) and development of a standalone application that most of the

available and existing models and tools lack. The developed evaluation model is a simulation model capable of site-specific techno-economic analysis with MCDM analysis taking into account societal and environmental impacts and aspects.

For the evaluation model development, a standardized modelling approach was used as depicted in Figure 6.1. The first step in modelling a system was to define the research topic completely and clearly. The main research topic was identified as evaluation of geothermal energy utilization options emphasizing the EGS projects. Therefore, the system that was to be modelled was a geothermal system that consist of both subsurface and surface phenomena. Once the system was identified, the necessary input data that was to be used in various calculation processes was determined and defined. Namely, the holistic approach used in the evaluation model development requires a great number of input parameters which are either direct user inputs or pre-defined and/or calculated default values specific to the case being analysed. The necessary data identification and collection process was based on the cooperation with partners on Horizon 2020 MEET project (GA No. 792037). Aside from data provided from consortium partners, other relevant data was also identified from sources (predominantly online sources) available from different studies, papers and other relevant literature that was intensively investigated during the first stage of evaluation model development [21], [23], [155], [238], [242], [296]–[300]. Furthermore, all input parameters can be divided into five main groups as follows (included list of some main input data):

- Subsurface parameters {
  - Site geological features
  - Geothermal fluid properties
- Surface technical parameters {
  - End-user option characteristics
  - Power plant equipment
  - Gathering system features
- Financial parameters {
  - Energy prices (heat and/or electricity)
  - Analysis parameters (e.g. discount rate)
  - Sources of financing
- Economic parameters {
  - Capital costs
  - O&M costs
  - Subsidied and incentives
- Environmental parameters {
  - Land use intensity
  - Conflict with other subsurface uses
  - Seismicity data
  - CO<sub>2</sub> emission factros and fuel-mix

Additionally, the evaluation model is based on modular structure. Each functional module represents a logical part of the comprehensive model and is used separately to pre-calculate,

simulate, or acquire data for further calculations. Each module can be altered and used differently without affecting the centrale core of the model. This modularity enables better tuning of the model to the system being modelled. Furthermore, each of the modules was verified (checked for proper functioning) separately prior to implementation of other sub-modules and compilation of modules into the evaluation model. After all modules that form a logical and functional partition of the evaluation model were checked, the evaluation model as a whole was validated for proper interconnection of previously verified functional modules. Once the model passed the validation process, the practical test of the model was performed on the real datasets of demonstration sites that were part of the Horizon 2020 MEET project. Based on the results and the analysis of the results the conclusions and recommendations on best utilization option of geothermal energy on different sites and in various geological, environmental and societal conditions could be proposed.

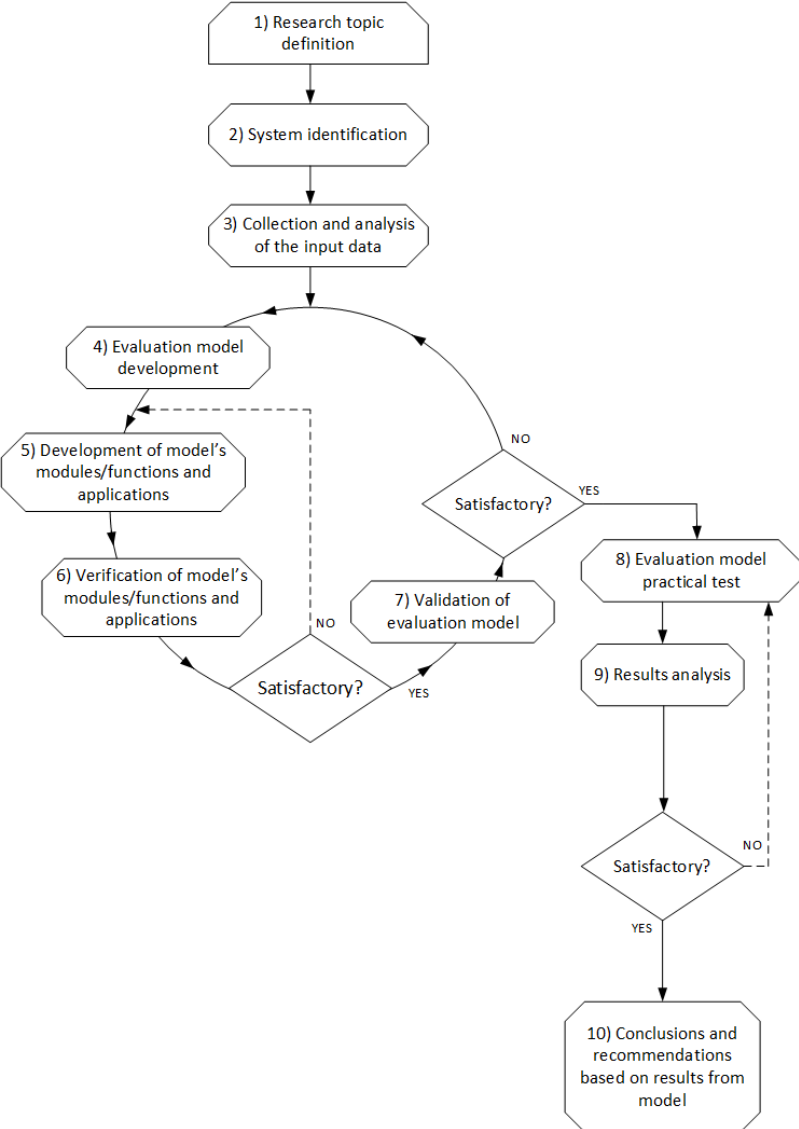

Figure 6.1. Flowchart of modelling approach applied in developing the evaluation model

The core of the evaluation model is a calculation of the produced energy (heat and/or electricity), followed by the financial analysis based on the discounted cash flow (DCF) as depicted in Figure 6.2. The energy production is determined on the basis of input data related to the potential end-user option (production mode being simulated), brine properties, ambient characteristic, parasitic load (to calculate the net production quantities) and gathering system features (mainly related to the pumping system). Different boundary conditions are defined to model heat transfer from brine to secondary fluid (for electricity generation) or direct heat use. Once the production quantities are calculated (heat or electricity or both), a financial analysis takes place. The main inputs are related to fixed and variable costs, available financial incentives, financial analysis parameters (inflation rate, tax rate, discount rate etc.), and funding sources (i.e., loans). Capital and O&M costs can be users' inputs, i.e., data pre-calculated exogenous of the evaluation model or costs calculated inside the model using the default cost-correlation functions.

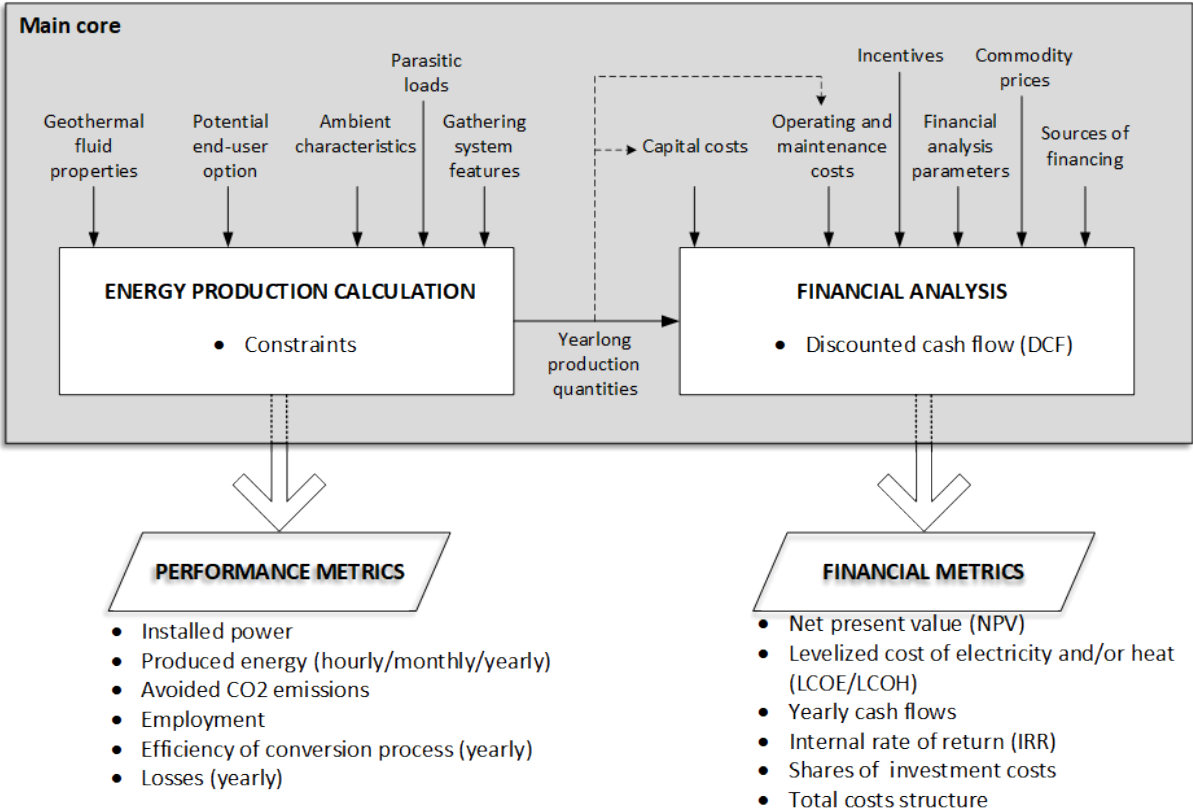

Figure 6.2. Schematic of input and output parameters from main core of the evaluation model

Output data from the evaluation model are available as raw data and in form of various charts that represent performance and economic metrics. Additionally, as mentioned in Section 6.1, these raw output data, that can be interpreted in whole only by the users with enough technical and financial background and knowledge, can further be processed to facilitate the

comparison of different scenarios using the developed integrated MCDM methodology. This MCDM methodology is integrated in a functional module.

The developed model features and concepts are schematically represented in Figure 6.3.

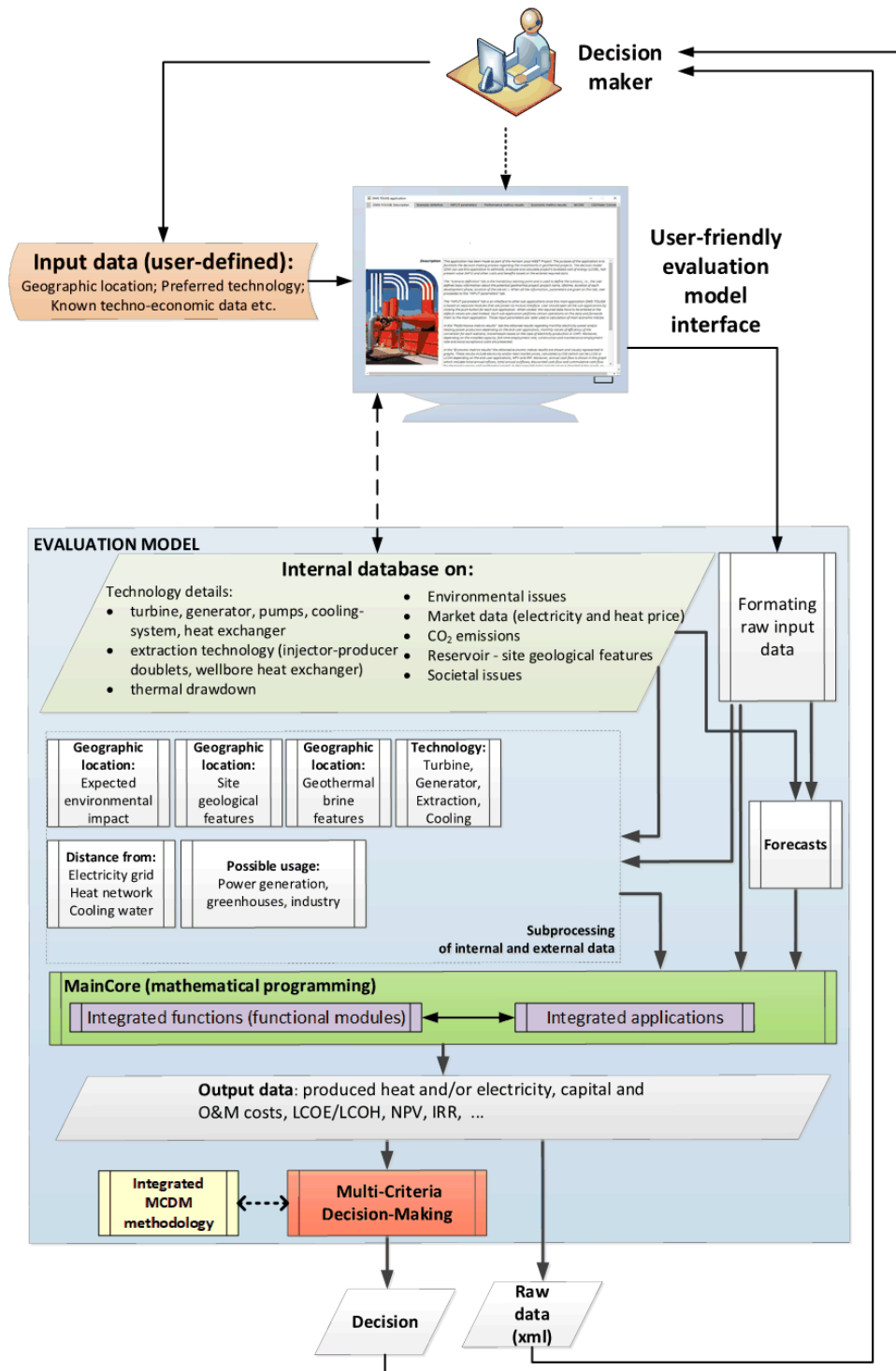

Figure 6.3. Depiction of the concept and main features of the developed evaluation model

### 6.2.1.1. Geothermal project depiction

In the developed evaluation model, the project development is divided in five main phases, where each phase has unique duration (Figure 6.4). By default, the duration of each phase is

set as in Table 6.1. Each phase includes activities and elements that incur different related costs, which in evaluation model can be estimated or inputted by a decision maker. These costs, along with the estimated electricity generation and/or heat production over a project’s lifetime, are the basis for the LCOE, NPC and IRR calculation for a defined scenario. The number of the activities in each phase, and consequently the capital and operating and maintenance (O&M) costs of the project, depend also on the state of the project, i.e., if it is a greenfield or a brownfield project.

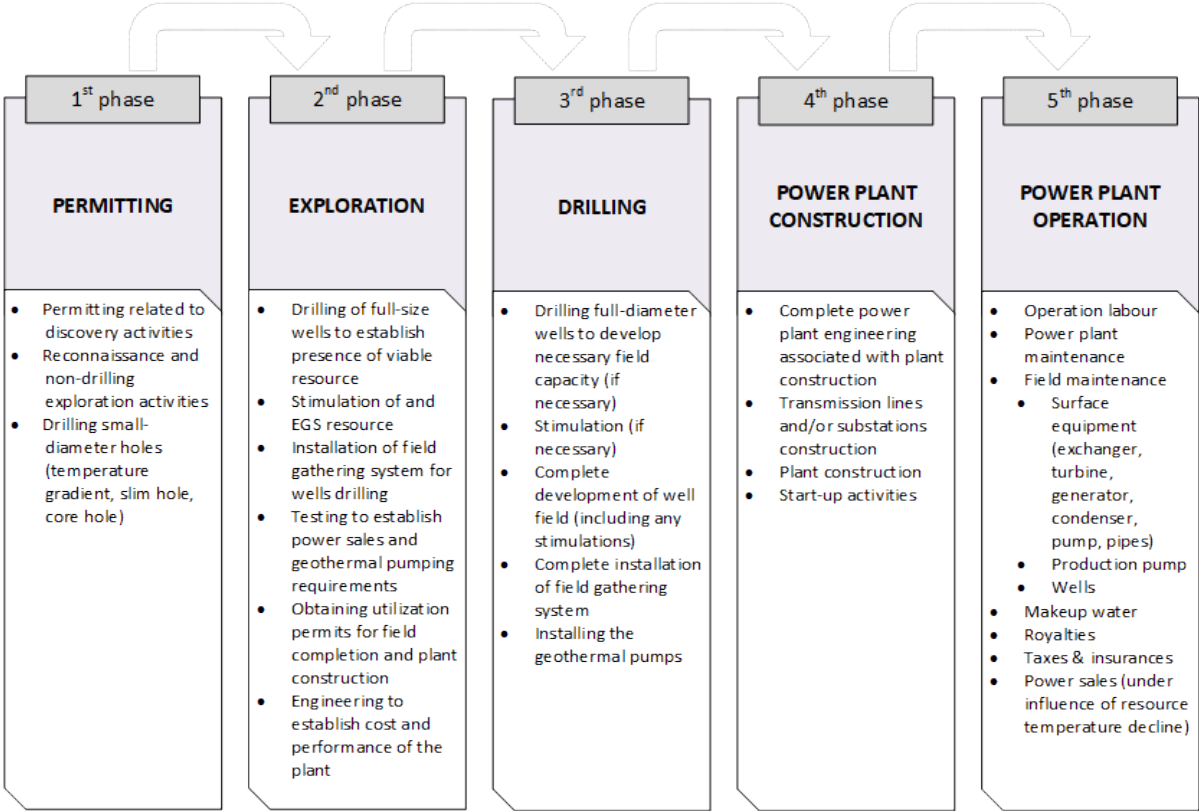

Figure 6.4. Geothermal project development phases and activities related to each one of the phase

Table 6.1. Duration of each phase in the geothermal project (default values)

Phase	Duration of the phase (default value) [years]
Permitting	2
Exploration	2
Drilling	2
Power plant construction	2
Power plant operation	User defined

6.2.2. MATLAB software

MATLAB (also known as MATrix LABoratory) is a software package that allows both numerical computing and modelling as well as a higher programming language for various

scientific and technical applications [301]. In addition, MATLAB is not only a programming language but also a programming environment as well.

MATLAB is widely used software in order to solve various mathematical problems, as well as a variety of calculations and simulations related to signal processing, control, regulation and system identification. The first version of MATLAB, a simple matrix laboratory was written in the late 1970s at the University of New Mexico and Stanford University for application in matrix theory, linear algebra, and numerical analysis and that first MATLAB version was not established as a programming language. In the early 1980s, it switched to C programming language with the addition of new capabilities, primarily in the areas of signal processing and automatic control. Since 1984, MATLAB has been available as a commercial product of MathWorks. Today, the properties of MATLAB exceed by far the original "matrix laboratory". It is an interactive system and programming language for general technical and scientific calculations. In addition to the basic system, there are numerous software packages that extend it to cover almost all areas of engineering: signal and image processing, 2D and 3D graphical representations, automatic control, system identification, statistical processing, time and frequency domain analysis, symbolic mathematics and many others. MATLAB is also designed as a system where the user can easily build their own tools and libraries and modify the existing ones [302].

Modern modelling is virtually impossible without computers or computer programs, which are used primarily for two purposes in modelling:

- Model development and
- Calculations execution.

The term "modelling and simulation" incorporates numerous, often complex activities involving three fundamental elements:

- A real system;
- A model; and
- A computer.

MATLAB was chosen for simulation and modelling of evaluation model based on the following advantages compared to "classic" programming languages like Fortran or C are:

- The interactive interface allows for rapid experimentation (MATLAB is an interpreted language unlike, for example, Fortran, which is compiled);
- Minimal care is needed about data structures (there are virtually no declarations variables and fields unless one wants to define something in a specific way);

- MATLAB makes programming quick and easy (due to the powerful matrix concept);
- Built-in graphics subsystem provides easy, high-quality and fast visualization. The graphical output interaction is quite simple, and data can be plotted and edited by using the graphical interactive tools) [303]; and
- Programs written in MATLAB (so-called m-files) are plain text files and are therefore fully portable between different operating systems/platforms.

There are also numerous available add-ons (toolboxes), i.e. groups of m-files for various speciality areas and there are numerous m-files and entire packages provided by the authors, at the same time, they make the users freely available over the internet [304]. Addition of these toolboxes can significantly improve MATLAB functionality with new sets of specialized functions that provided more dedicated operability.

At first, MATLAB had IEEE standard 754 double-precision floating-point data type (64-bit format). Gradual increase of users and demand on different new applications and larger data sets required also additional data types such as:

- Single Precision and Integer;
- Sparse Matrices;
- Cell Arrays;
- Structures;
- Objects and others.

During the MATLAB evolution process, simple terminal applications were replaced with more sophisticated GUI with dedicated windows for graphics, editing, and other tools, making MATLAB more user-friendly than other comparable software tools. The MATLAB desktop that was released for the first time in year 2000 was used in scope of evaluation model development. As Figure 6.5 depicts, it consists of four working panels: the current folder viewer (left), the workspace viewer (right), the editor/debugger (top centre), and the traditional command window (bottom centre). Each panel can be closed or undocked into a standalone window [305]. The University of Zagreb Faculty of Electrical Engineering and Computing (UNIZG-FER) has a long history of using MATLAB both for educational and research purposes. Most of domestic and international research projects, where UNIZG-FER is involved, that require some kind of modelling or programming are utilizing MATLAB functionalities.



Large practical experience of UNIZG-FER staff on MATLAB software applications, MATLAB's intrinsic user-friendly working environment, a huge number of available toolboxes and great flexibility and operational performance were main driving factors for decision on using MATLAB for development of evaluation model.

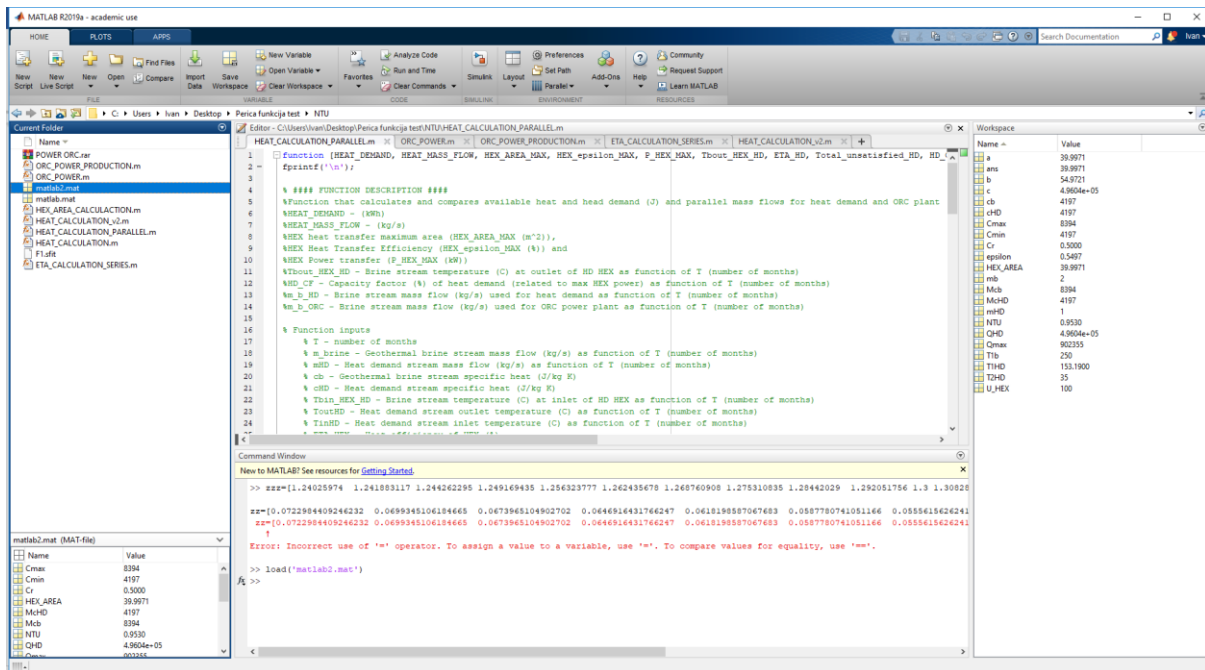

Figure 6.5. MATLAB desktop interface and working environment

### 6.3. PROJECT SIZING – GEOTHERMAL ENERGY UTILIZATION MODES

The basic concept used to size the EGS project is based on the following main input parameters:

- The resource temperature;
- Geothermal brine characteristics;
- End-user option characteristics;
- Ambient conditions; and
- Power plant/energy facility type.

The size of the project is primarily defined by the installed capacity regarding electricity generation and/or heat production. Additionally, the model is best suited for evaluation of EGS resources within a temperature range between 60 and 175 °C. Geothermal brine characteristics determine the extent of possible heat exchange in the heat exchanger. End-user option characteristics are mainly related to the power grid features such as voltage and distance to the connection point or to the characteristic of heating network and secondary loop

fluid which brings the transferred heat to direct utilization users. Ambient conditions are important especially in the case of electricity generation when air-cooling condenser type is used. Preferred energy facility type determines the energy production, and consequently revenues and costs, both investment and operating costs.

Specific mode or approach of geothermal energy utilization is affected by aforementioned site-specific parameters such as temperature and available heat energy from geothermal brine, proximity and specific characteristics of heat demand and also proximity to power network with suitable voltage level for connection of ORC generator. Regardless of site specifics, four basic production modes of final energy (transformed from geothermal energy) are distinguished and modelled within the evaluation model:

- Only heat production;
- Only electricity production;
- CHP production (heat and electricity) in series configuration; and
- CHP production (heat and electricity) in parallel configuration.

Using evaluation model user can assess economical results for all predefined final energy production modes for a specific site and determine which one is most suited (if any) for given site. Alternatively, user can decide to assess specific final energy production mode on different sites and based on comparison results determine the most suitable location for a given production mode.

### 6.3.1. Reservoir productivity decline

Nearly all geothermal resources experience some decline in productivity over time which is closely related to the fact that all reservoirs have finite size. This decline can occur as reduced flow of geothermal brine, temperature decline, and/or pressure decline of the produced geothermal fluid. Usually, when talking about binary power plants, the downhole production pumps offset the decline in reservoir pressure. Therefore, the premise for estimates how declining reservoir productivity influences the energy output is based on the well flow rate remaining constant with time and the pressure drawdown has reached its quasi-steady state value. As such, neither flow nor pressure is included in characterization of declining resource productivity. Namely, this decrease is characterized as a declining resource temperature that is based on the following relationship:

$$T_n = T_{initial} * (1 - t_{gf})^n , \quad (6.1)$$

where  $T_n$  is the temperature of the geothermal brine in the year  $n$  [°C],  $T_{initial}$  is the temperature of the geothermal brine at the beginning of the project (initial temperature) [°C],  $t_{gf}$  is the annual decline rate [%], and  $n$  is the time step  $n \in T$  ( $T$  is the lifetime of the project).

### 6.3.2. Only heat production mode

Only heat production mode of final energy assumes that geothermal energy extracted from a geothermal reservoir and brought by geothermal brine to the surface via production well(s) is used for only heat related purposes: district heating, greenhouse heating, industry, etc.

This production mode consists of two circulating loops as schematically depicted in Figure 6.6. Hot circulating loop (primary loop) is represented by geothermal fluid loop that flows through pipelines from well to heat exchanger (left part in Figure 6.6). In the heat exchanger, heat is transferred to secondary, colder circulating loop (secondary loop) that brings transferred heat to final consumers.

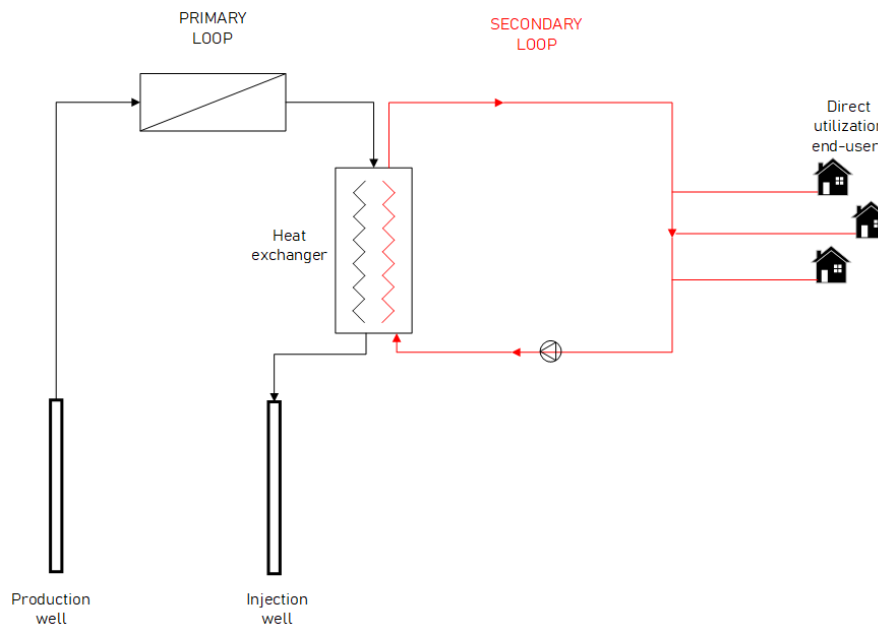

Figure 6.6. Only heat production mode

It is assumed and modelled that the counter-flow heat exchanger will be utilized for direct heating purposes, precisely, the shell tube heat exchanger. To calculate the parameters of the heat exchanger, the model uses the Number of Transfer Units (NTU) effectiveness method. Additionally, the brine temperature at the inlet of the heat exchanger primary loop (hot loop) and heating fluid temperatures (both at the inlet and at the outlet) in the secondary loop of heat exchanger (cold loop) are assumed to be known in advance. Output results in this mode can help users to get better assessment of key parameters regarding heat oriented EGS project

development based on the inputs (heat demand, brine mass flow and temperature and mass flow, etc.). For example, user will get information on how much heat demand cannot be covered in certain time period and also get recommendations regarding heat exchanger basic technical features such as thermal power, effectiveness and physical area needed for heat transfer between primary and secondary loop and others. These recommendations will have an influence on heat exchanger-related costs. Due to the expected lower reinjection temperatures of brine, it is expected that heat exchangers for this purpose will be more expensive compared to those used for higher brine reinjection temperatures, predominantly regarding more significant corrosion and scaling risks. These costs can be lowered by more frequent maintenance, but consequently increasing maintenance costs and decreasing the availability of heat transfer, therefore benefit-cost of more frequent maintenance should be carefully balanced.

Main costs in this production mode are costs related to heat exchanger construction and maintenance, and also costs related to piping construction. This production mode will be usually used in cases of rather low brine temperature when ORC technology is economically, and technically not feasible and geothermal heat can only be transferred for the heat consumption. It will be also utilized in cases when there is high enough brine temperature for electricity production via ORC but connection to the existing power grid is impossible to be made, either due to the large distance or too high voltage level of nearest power grid.

#### 6.3.2.1. Heat production calculation

This functional module is used for calculation of available geothermal heat and comparison with required heat demand, to determine how much heat demand (HD) could be covered with the production from geothermal plant. This functional module is used to calculate the available geothermal heat for both ‘Only heat production mode’ and ‘CHP production mode in series configuration’ (described in Section 6.3.4).

Main parameters relevant for calculations in this model are (Figure 6.7):

- $U_{HEX}$  - overall heat transfer coefficient of heat exchanger, in  $[W/m^2K]$ ,
- $c_{HD}$  - heat demand fluid specific heat capacity, in  $[J/kg K]$ ,
- $c_b$  - geothermal brine specific heat capacity, in  $[J/kg K]$ ,
- $m_{HD}$  - heat demand fluid mass flow, in  $[kg/s]$ ,
- $m_b$  - geothermal brine mass flow, in  $[kg/s]$ ,
- $T_{inb}$  - geothermal brine temperature at inlet of HD heat exchanger, in  $[^{\circ}C]$ ,
- $T_{outb}$  - geothermal brine temperature at outlet of HD heat exchanger, in  $[^{\circ}C]$ ,

- $T_{inHD}$  - heating fluid temperature at inlet of HD heat exchanger, in [°C],
- $T_{outHD}$  - heating fluid temperature at outlet of HD heat exchanger, in [°C],
- $\eta_{HEX}$  - heat exchanger heat loss coefficient, in [%] and
- $T_0$  - dead state temperature in [°C].

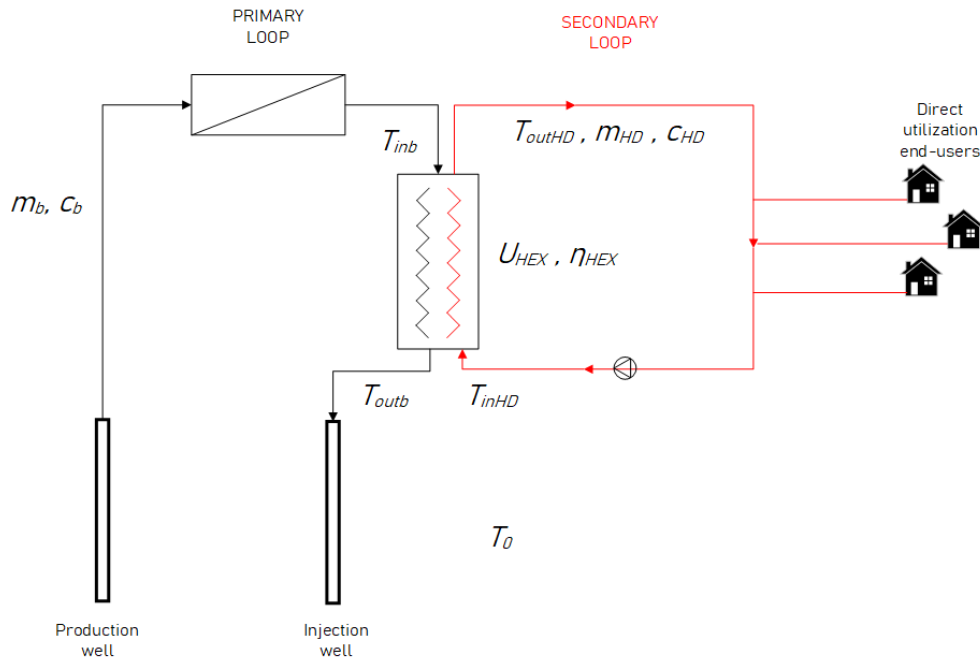

Figure 6.7. Heat calculation functional module graphical description

There are couple constraints in this module which are used to represent realistic heat transfer in such a system. In case one of these constraints is not achieved, the module prompts error, and consequently some input parameters must be adjusted.

Constraints:

- $T_{inHD}$  must be greater than  $T_0$
- $T_{inb}$  must be greater than  $T_{outHD}$ .

Only in theory, considering perfect heat exchanger,  $T_{inb}$  could be equal to  $T_{outHD}$ . That is never the case in practice. Therefore, there certain temperature safe margin ( $TSM$ ) should be set (by end-user) that is equal to the difference between  $T_{inb}$  and  $T_{outHD}$ . In scope of evaluation model approach, it is assumed that the differences between  $T_{inb}$  and  $T_{outHD}$  and between  $T_{outb}$  and  $T_{inHD}$  are the same.

Additionally, the supply temperature of the heat demand side  $T_{outHD}$  and return temperature of the heat demand side  $T_{inHD}$  are defined as monthly values for one calendar year. In the similar manner the seasonality of heating demand is modelled, which also allows modelling different types of heating demand types (district heating, greenhouse heating,

industrial heat production, etc.). This ‘representative’ temperature distribution throughout the year is then used repeatedly for every year during the entire lifetime of the project.

Geothermal brine temperature at the outlet of the heat exchanger is calculated using Equation (6.2):

$$T_{outb} = T_{inb} - \frac{m_{HD} \cdot (T_{outHD} - T_{inHD}) \cdot c_{HD}}{m_b \cdot c_b} . \quad (6.2)$$

Heat demand ( $HD_S(i)$ ) that can be satisfied for each of  $T$  time steps ( $i$ ) is calculated in [kWh] using Equation (6.3):

$$HD_S(i) = \frac{(T_{inb}(i) - T_{outb}(i)) \cdot m_b(i) \cdot c_b \cdot \eta_{HEX}}{1000} . \quad (6.3)$$

Additionally, the time step in evaluation model is set to be one month, therefore the heat demand that can be satisfied as calculated with Equation (6.3) must be multiplied by 730 (average number of hours in one month). Additionally, when calculating the production, the power plant maintenance period must be considered. Namely, in some percentage of the year, the power plant is not available for production due to maintenance and repair works. For geothermal power plants this is usually around 10% of the year, meaning that the power plant availability is around 90%. In developed evaluation model, the power plant availability can be modelled as percentage of the year ( $ppa$ ) or specific month of maintenance can be defined ( $MoM$ ) when the power plant is not operating. In case if  $ppa$  is defined, the production from Equation (6.3) is multiplied by the time when the power plant is available ( $ppa/100\%$ ). In case when  $MoM$  is defined (the power plant is not working the whole month of the year), the production from Equation (6.3) is equal to zero for the whole duration of the month, the rest of the year the production is maximum possible.

Heat fluid mass flow ( $m_{HDS}(i)$ ) that can be satisfied for each of  $T$  time steps ( $i$ ) is calculated in [kg/s] using Equation (6.4):

$$m_{HDS}(i) = \frac{(T_{inb}(i) - T_{outb}(i)) \cdot m_b(i) \cdot c_b \cdot \eta_{HEX}}{(T_{outHD}(i) - T_{inHD}(i)) \cdot c_{HD}} . \quad (6.4)$$

In cases when required mass flow of heating fluid ( $m_{HD}(i)$ ) is lower than calculated heat fluid mass flow that can be satisfied  $m_{HDS}(i)$  warning message from model is issued to inform the user appropriately.

Furthermore, the efficiency ( $\eta_{HD}(i)$  in [%]) of the whole conversion process in this production mode for each of  $T$  time steps ( $i$ ) is calculated using Equation (6.5):

$$\eta_{HD}(i) = \frac{HD_S(i) \cdot 100 \cdot 1000}{(T_{inb}(i) - T_{outb}(i)) \cdot m_b(i) \cdot c_b} \quad (6.5)$$

It must be noted that in the case when time step is one month, such as in evaluation model, efficiency for  $\eta_{HD}(i)$  from Equation (6.5) should be divided by 730 (average monthly number of hours). Additionally, as when calculating the heat production (Equation (6.3)) the power plant maintenance period must be considered. The approach is the same as described above in the text.

Additionally, this functional module also incorporates the sub-module for calculation of the heat exchanger dimensions, which is thoroughly described in next Section 6.3.2.2. This sub-module is used to calculate and then suggest the heat exchanger dimensions based on calculated heat demand and geothermal fluid parameters in the scope of *heat calculation* module. The user is informed on following suggested heat exchanger parameters:

- $Area_{HEX}$  - heat exchanger heat transfer area [ $m^2$ ],
- $\varepsilon_{HEX}$  - heat exchanger heat transfer efficiency [%], and
- $P_{HEX\_HD}$  - heat exchanger power for heat transfer [kW].

#### 6.3.2.2. Heat exchanger area calculation

As mentioned, to calculate the parameters of the heat exchanger, the model uses the Number of Transfer Units (NTU) effectiveness method. This sub-module is used to evaluate the characteristics of heat exchanger for conversion of geothermal energy from geothermal brine to secondary fluid in the secondary loop where the heat is used for direct utilization purposes. The heat exchanger should be properly dimensioned to be capable to satisfy features of secondary heat usage cycle. These parameters include primary and secondary fluid temperature and mass flow. Basic heat exchanger parameters in this regard are heat transfer area,  $Area_{HEX}$  in [ $m^2$ ], and heat transfer coefficient  $U_{HEX}$  in [ $W/m^2K$ ]. It is assumed that counterflow heat exchanger is utilized for direct heating purposes, more specifically shell tube heat exchanger. Plate heat exchangers are generally cheaper than shell tube type, but their maintenance frequency and related costs, especially with low-temperature geothermal brine where scaling has an important role, are main reason for their exclusion from evaluation model.

It is assumed that inlet brine temperature on primary (hot loop) side of heat exchanger,  $T_{inb}$ , and both inlet  $T_{inHD}$ , and outlet,  $T_{outHD}$  heat fluid temperature for heat demand (HD) on secondary (cold loop) side of heat exchanger are known in advance and provided by the user.

It is also assumed that following parameters are known (provided by the user or provided as outputs from other functional modules/functions):

- $U_{HEX}$  - overall heat transfer coefficient of heat exchanger, in  $[W/m^2K]$ ,
- $c_{HD}$  - heat demand fluid specific heat, in  $[J/kg K]$ ,
- $c_b$  - geothermal brine specific heat, in  $[J/kg K]$ ,
- $m_{HD}$  - heat demand fluid stream mass flow, in  $[kg/s]$ ,
- $m_b$  - geothermal brine stream mass flow, in  $[kg/s]$  and
- $\eta_{HEX}$  - heat exchanger heat loss coefficient, in  $[\%]$ .

The main purpose of this sub-module is to provide an estimation of maximum power, expected maximum efficiency of a targeted heat exchanger and consequently necessary heat transfer area within heat exchanger.

Required heat transfer power of heat exchanger is determined by required heat load parameters (mass flow and both, inlet and outlet temperatures of heating fluid) and calculated using Equation (6.6):

$$P_{HEX\_HD} = \frac{m_{HD} \cdot (T_{outHD} - T_{inHD}) \cdot c_{HD}}{\eta_{HEX}} . \quad (6.6)$$

The heat transfer efficiency,  $\varepsilon_{HEX}$ , of heat exchanger is calculated as the ratio between required heat transfer power,  $P_{HEX\_HD}$ , and maximum heat transfer  $P_{HEX\_max}$ , using Equation (6.7) and Equation (6.8):

$$\varepsilon_{HEX} = \frac{P_{HEX\_HD}}{P_{HEX\_max}} \quad (6.7)$$

$$P_{HEX\_max} = C_{min} \cdot (T_{inb} - T_{inHD}) . \quad (6.8)$$

The parameter  $C_{min}$  represents the minimum heat capacity of hot and cold fluid calculated as the product of specific heat capacity and mass flow of each fluid using Equation (6.9):

$$C_{min} = \min(m_b \cdot c_b, m_{HD} \cdot c_{HD}) . \quad (6.9)$$

Then the Number of Transfer Units ( $NTU$ ) of the counterflow heat exchanger is calculated using Equation (6.10):

$$NTU = \frac{\ln(1 - \varepsilon_{HEX})}{\frac{(1 - \varepsilon_{HEX} \cdot C_r)}{C_r - 1}} , \quad (6.10)$$



where parameter  $C_r$  is the specific heat ratio calculated as (Equation (6.12)) the ratio between minimum heat capacity of hot and cold fluid  $C_{min}$  and maximum heat capacity of hot and cold fluid  $C_{max}$  (Equation (6.11)).

$$C_{max} = \max(m_b \cdot c_b, m_{HD} \cdot c_{HD}) \quad (6.11)$$

$$C_r = \frac{C_{min}}{C_{max}} \quad , \quad C_r < 1 \quad (6.12)$$

Finally, the required heat exchanger heat transfer area is calculated using Equation (6.13):

$$Area_{HEX} = \frac{NTU \cdot C_{min}}{U} \quad . \quad (6.13)$$

### 6.3.3. Only electricity production mode

Only electricity production mode of final energy assumes that geothermal energy extracted from the geothermal reservoir and brought by geothermal brine is used for only power system demand. Binary power plants are modelled and based on the Organic Rankine Cycle (ORC) units and the ORC unit model is based on real data sets of operational ORC units with R1233zd as a working fluid. In contrast to different heat demands that usually require different heat parameter, once when geothermal energy is converted to electricity via ORC unit, it is a standardized product (50 Hz for Europe and usually 0.4 kV) ready to be delivered to the power system.

As in case of only heat production mode, this production mode also consists of two circulating loops as schematically depicted in Figure 6.8. In hot circulating loop (primary loop) the geothermal fluid flows through pipelines from production well(s) to heat exchanger and after the heat transfer it is directed in injection well(s). In heat exchanger the heat is transferred to secondary, colder organic working fluid that transforms thermal energy to electricity in turbine using Rankine cycle. Namely, in the ORC system, the fluid flow is divided into four steps. The working fluid is heated up and vaporized in a hot heat exchanger (the evaporator), and at this point, the temperature of the working fluid is the highest. This saturated steam drives the turbine, which enables electricity production by lowering the fluid pressure to its low level. The fluid is then condensed in a cold heat exchanger (condenser) and pumped again into the evaporator, increasing thereby the fluid's pressure. As for the condensers, the most commonly used heat rejection equipment at binary geothermal power plants are the air-cooled condensers. The use of air eliminates the requirement for makeup water which decreases the environmental impact of a power plant. However, compared to

water cooling towers, air-cooled condensers require more space and represent a larger parasitic power load on the plant. Therefore, for the binary plants, the major equipment components estimated are turbine-generator, air-cooled condenser, geothermal heat exchangers, and working fluid pumps, as depicted in Figure 6.9.

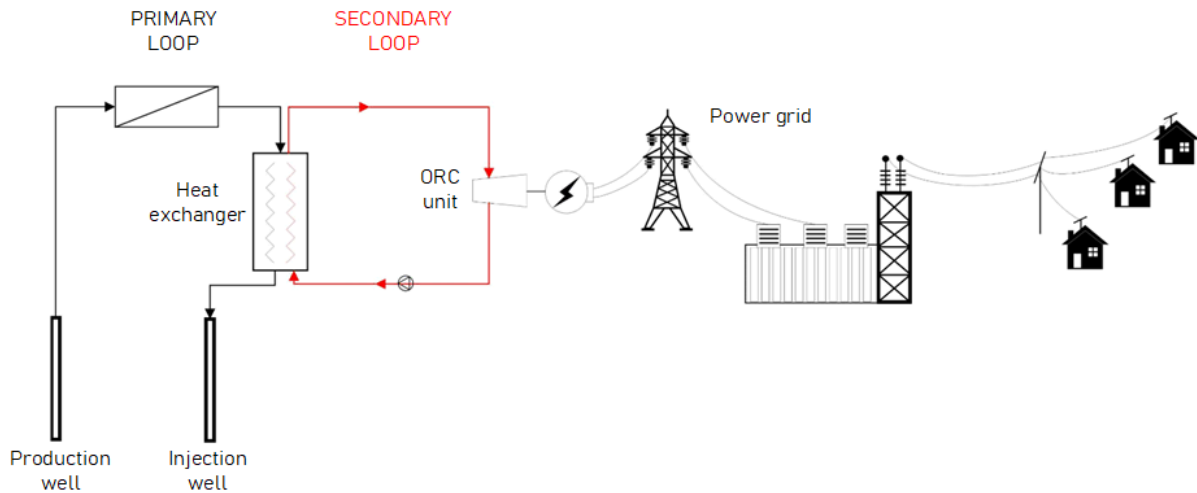

Figure 6.8. Only electricity production mode

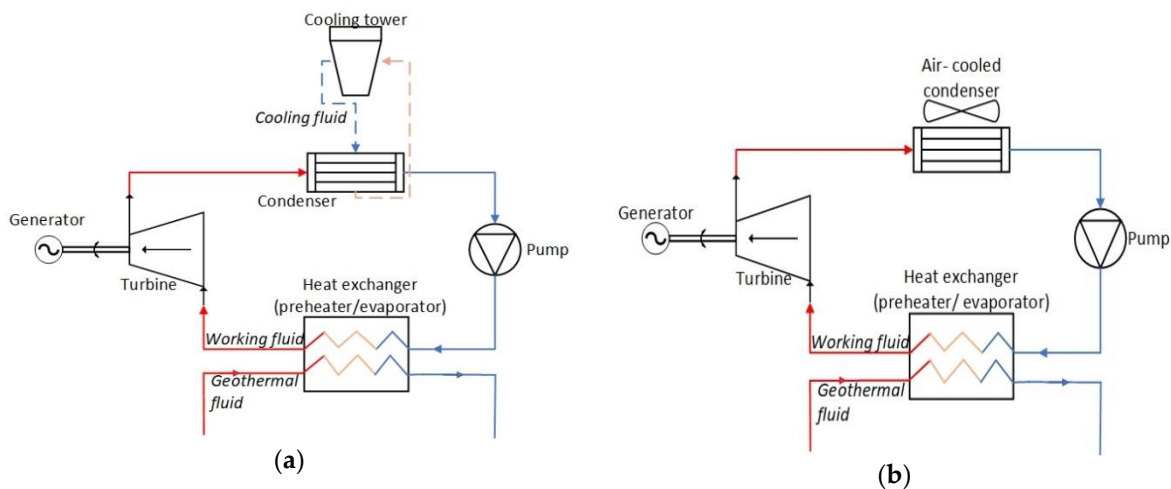

Figure 6.9. Schematic diagram of a basic binary cycle power plant: (a) water-cooled condenser, (b) air-cooled condenser (published in: [144])

Output results in this mode can help users to get better assessment of key parameters regarding electricity oriented EGS project development based on the inputs. For example, user will get information on how much electricity can be generated in certain time period and also get recommendations regarding ORC power plant basic technical features such as recommended installed ORC power, recommended temperature difference between inlet and outlet of ORC heat exchanger primary loop and others. Output power will vary according to the season and long-term due to the temperature degradation effect (if significant). Therefore,

based on provided recommendations and suggestions, the user decides on the final ORC technical features in order to increase targeted EGS project economic feasibility.

This production mode requires a construction of a proper connection to the power grid. This connection line imposes significant additional costs that can significantly affect the feasibility of the analysed EGS project. In addition, electricity transfer to the existing power grid through connection lines or cables inevitably imposes losses ranging from a few percentages to almost 10-20% of available net ORC output power, predominantly depending on connection length and cross-section area of connection lines or cables. These losses impose indirect costs in a way that they decrease expected revenues from selling electricity on the market or through guaranteed subsidy schemes, depending on the country and site-specific available support schemes.

#### 6.3.3.1. ORC installed capacity

For the only electricity production mode first the possible installed capacity is calculated and then the electricity production is calculated based on the chosen installed power.

This module is used to calculate and evaluate main ORC power plant parameters in terms of possible installed capacity. It provides several values regarding site-specific available installed ORC power plant capacity. The ORC type of binary geothermal power plants requires deep thermodynamic expertise in the field of thermodynamics. Namely there are numerous, more or less complex conceptual models of ORC power plant operation available in literature [300], [306]–[310]. There are different approaches in ORC heat exchanger construction (with or without preheating of working fluid), working fluid utilization and others. For the developed evaluation model, the empirical approach in modelling an ORC unit was used which is based on the real data points provided by a Horizon 2020 MEET project consortium partner ENOGIA [311] and ES-Géothermie.

To calculate the value of possible installed capacity and consequently the produced electricity during a specific time period following input parameters are necessary for the approach used in this thesis (Figure 6.10):

- $m_b$  - geothermal brine mass flow, in [kg/s],
- $c_b$  - geothermal brine specific heat capacity, in [J/kg K],
- $T_{inb}$  - geothermal brine temperature at the inlet of the heat exchanger, in [°C],
- $DT$  - difference of temperature on primary (geothermal brine loop) side of ORC dedicated heat exchanger ( $T_{inb} - T_{outb}$ ). This parameter is defined by the user

which consequently enables calculation of geothermal brine temperature at the outlet of the heat exchanger.

- $T_{cool\_in}$  - temperature of coolant at inlet to ORC condenser, in [°C],
- $T_{inj}$  – geothermal brine injection temperature, in [°C],
- $\eta_{ORC}\{T_{inb}, DT\}$  - net ORC power plant efficiency as function of geothermal brine extraction temperature  $T_{inb}$  and  $DT$ , and
- $F_{cool}\{T_{inb}, DT\}$ - net ORC power plant efficiency correction factor that takes into account different temperatures of ORC cycle coolant as function of geothermal brine extraction temperature and  $DT$ .

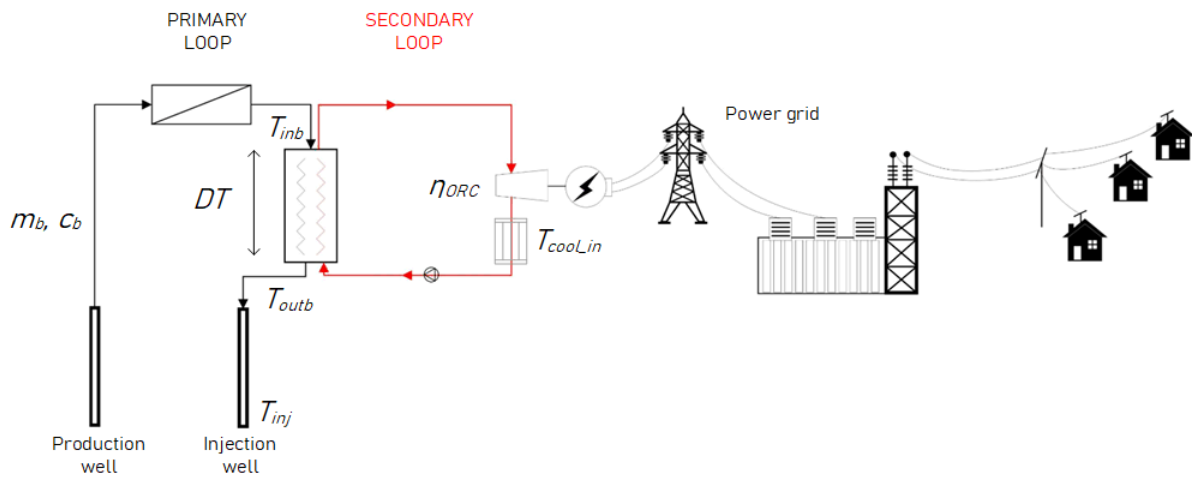

Figure 6.10. Electricity calculation functional module graphical description

As it can be observed, both  $\eta_{ORC}$  and  $F_{cool}$  are functions of two variables. In addition, there was limited number of ORC operating points available from ENOGIA. For that reason, ‘MATLAB Curve Fitting Tool’ was used to approximate these three-dimensional relationships. Polynomial approximation including third degree was performed to calculate both  $\eta_{ORC}$  and  $F_{cool}$ .

Figure 6.11 shows best fitted surface for  $\eta_{ORC}$  ( $z$  in Figure 6.11) as function of geothermal brine extraction temperature ( $y$  in Figure 6.11) and  $DT$  ( $x$  in Figure 6.11).

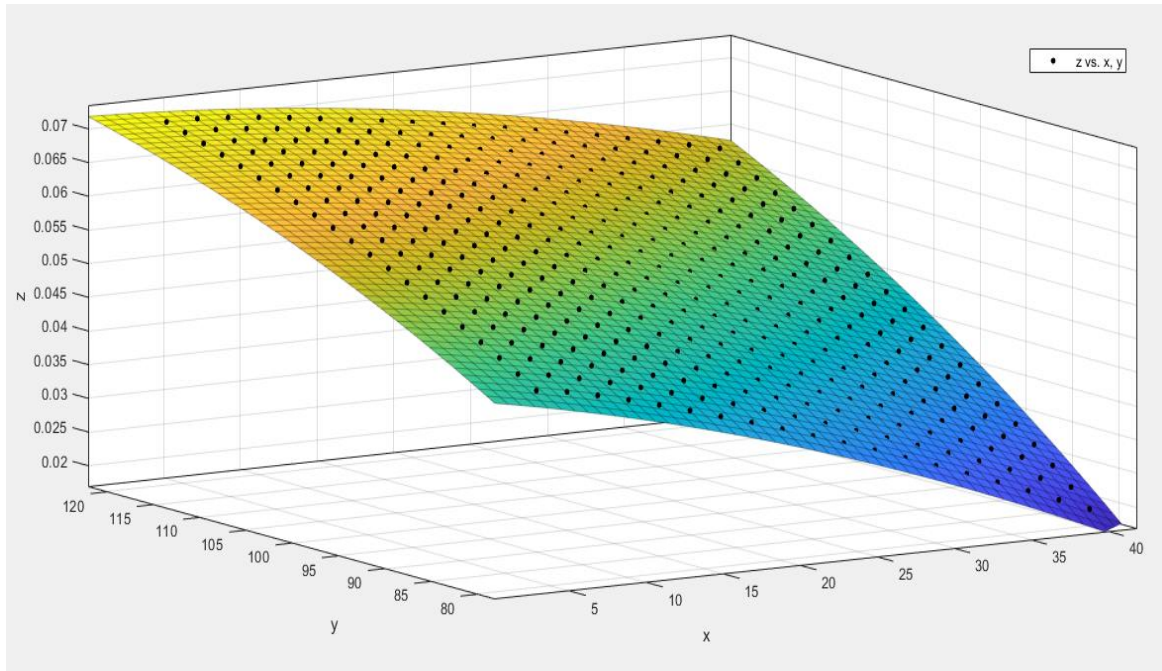

Figure 6.11. MATLAB Curve Fitting Tool approximation of ORC efficiency

Equation (6.14) represents functional relationship between net ORC power plant efficiency ( $z$ ), brine extraction temperature ( $y$ ) and  $DT$  ( $x$ ):

$$z(x,y) = \eta_{ORC} = p00 + p10 \cdot x + p01 \cdot y + p20 \cdot x^2 + p11 \cdot x \cdot y + p02 \cdot y^2 + p21 \cdot x^2 \cdot y + p12 \cdot x \cdot y^2 + p03 \cdot y^3 \quad (6.14)$$

Values of corresponding polynomial coefficients used in Equation (6.14) are following:

- $p00 = -0.06849$ ,
- $p10 = -0.001452$ ,
- $p01 = 0.002209$ ,
- $p20 = -1.017 \cdot e^{-5}$ ,
- $p11 = 1.639 \cdot e^{-5}$ ,
- $p02 = -1.096 \cdot e^{-5}$ ,
- $p21 = 3.241 \cdot e^{-8}$ ,
- $p12 = -4.203 \cdot e^{-8}$  and
- $p03 = 1.866 \cdot e^{-8}$ .

The obtained parameters of quality (goodness) of fitting are following:

- $SSE$ :  $5.587 \cdot e^{-5}$ ,
- $R - square$ :  $0.999$ ,
- $Adjusted R - square$ :  $0.9989$ , and
- $RMSE$ :  $0.0003687$ .

Based on these excellent fitting parameters, it was decided that the chosen approximation for three-dimensional relationships between net ORC power plant efficiency, brine extraction temperature and  $DT$  is applicable for utilization in evaluation model. However, it should be noted that the relationship from Equation (6.14) is best suited for geothermal brine extraction temperature values  $T_{inb}$  in range from 80 °C to 120 °C and for  $DT$  values in range from 0 °C to 40 °C. In cases when Equation (6.14) is used for values of  $T_{inb}$  lower than 80°C, slightly less accurate results can be expected.

To approximate the  $F_{cool}$  the same approach was used. Figure 6.12 shows best fitted surface for  $F_{cool}$  ( $z$  in Figure 6.12) as function of ORC cycle coolant temperature ( $y$  in Figure 6.12) and  $DT$  ( $x$  Figure 6.12)

Equation (6.15) represents functional relationship between net ORC power plant efficiency correction factor ( $z$ ), brine extraction temperature ( $y$ ) and ORC cycle coolant temperature ( $x$ ):

$$z(x,y) = F_{cool} = r00 + r10 \cdot x + r01 \cdot y + r20 \cdot x^2 + r11 \cdot x \cdot y + r02 \cdot y^2 + r30 \cdot x^3 + r21 \cdot x^2 \cdot y + r12 \cdot x \cdot y^2 + r03 \cdot y^3 \quad (6.15)$$

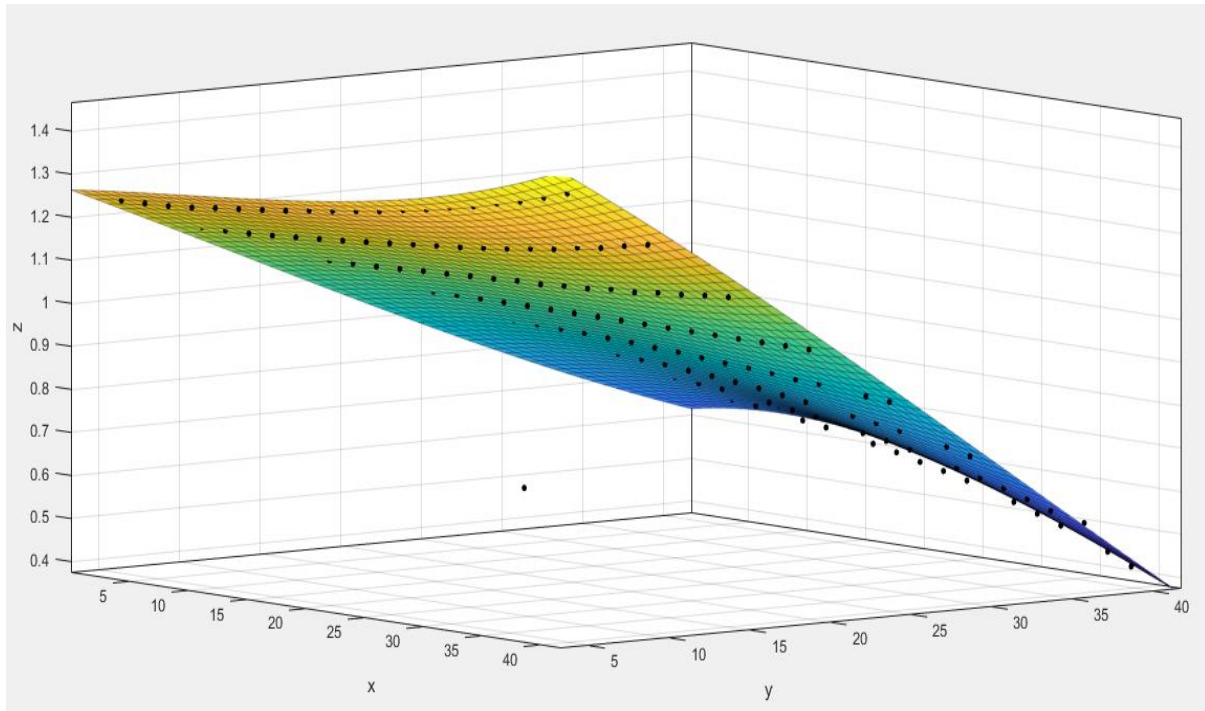

Figure 6.12. MATLAB Curve Fitting Tool approximation of efficiency correction factor regarding coolant temperature

Values of corresponding polynomial coefficients used in Equation (6.15) are following:

- $r00 = 1.398$  ,
- $r10 = -0.005579$  ,
- $r01 = -0.01981$ ,

- $r_{20} = 0.0002613$  ,
- $r_{11} = 0.0002315$  ,
- $r_{02} = 3.141 \cdot e^{-5}$  ,
- $r_{03} = -5.709 \cdot e^{-7}$
- $r_{21} = -1.045 \cdot e^{-5}$  ,
- $r_{12} = -1.261 \cdot e^{-6}$  , and
- $r_{03} = -2.444 \cdot e^{-7}$  .

The obtained parameters of quality (goodness) of fitting are following:

- *SSE*: 0.1206 ,
- *R – square*: 0.9871 ,
- *Adjusted R – square*: 0.9864 , and
- *RMSE*: 0.02836 .

Based on these excellent fitting parameters, it was decided that the chosen approximation for three-dimensional relationships between net ORC power plant efficiency, brine extraction temperature and ORC cycle coolant temperature is applicable for utilization in evaluation model. However, it should be noted that relationship from Equation (6.15) is best suited for ORC cycle coolant temperature values in the range from 0 °C to 40 °C and for *DT* values in range from 0 °C to 40 °C.

As mentioned, the three-dimensional relationships from Equation (6.14) and Equation (6.15) are used in power plant efficiency calculations for temperatures of geothermal brine extraction temperature values  $T_{inb}$  in range from 80 °C to 120 °C and for *DT* values in range from 0 °C to 40 °C. For the temperatures of geothermal brine  $T_{inb} \geq 140$  °C the data points provided from ES-Géothermie were used to find the polynomial approximation of the  $\eta_{ORC}$ . Therefore, for temperatures of the geothermal brine (at the inlet of the heat exchanger) that are equal or higher than 140°C following Equation (6.16) represent functional relationship between net ORC power plant efficiency (*z*), brine extraction temperature  $T_{inb}$  (*y*) and ORC cycle coolant temperature  $T_{cool,in}$  (*x*):

$$\begin{aligned}
 z(x, y) = \eta_{ORC}^{III} & \\
 &= q_{00} + q_{10} \cdot x + q_{01} \cdot y + q_{20} \cdot x^2 + q_{11} \cdot x \cdot y \\
 &+ q_{02} \cdot y^2
 \end{aligned} \tag{6.16}$$

Values of corresponding polynomial coefficients that are used are following:

- $q_{00} = 0.02134$ ,

- $q10 = 0.0009825$ ,
- $q01 = -0.001453$ ,
- $q20 = -3.596 \cdot e^{-8}$ ,
- $q11 = 2 \cdot e^{-6}$ , and
- $q02 = 3.5 \cdot e^{-6}$ .

Furthermore, since there was a gap between the datasets provided by ENOGIA and Es-Géothermie, i.e., the data for the for the geothermal brine temperatures between 120 °C and 140°C needed to be approximated using another polynomial approximation. Therefore, Equation (6.17) represent functional relationship between net ORC power plant efficiency ( $z$ ), brine extraction temperature  $T_{inb}$  ( $y$ ) and ORC cycle coolant temperature  $T_{cool\_in}$  ( $x$ ) for  $120^{\circ}C \leq T_{inb} < 140^{\circ}C$ :

$$z(x,y) = \eta_{ORC}^{II} = s00 + s10 \cdot x + s01 \cdot y + s20 \cdot x^2 + s11 \cdot x \cdot y + s02 \cdot y^2 \quad (6.17)$$

Values of corresponding polynomial coefficients that are used are following:

- $s00 = -0.1204$ ,
- $s10 = 0.001789$ ,
- $s01 = 0.0005824$ ,
- $s20 = 2.616 \cdot e^{-19}$ ,
- $s11 = -1.638 \cdot e^{-5}$ , and
- $s02 = 2.931 \cdot e^{-6}$ .

Now, the available ORC installed power in [MW] for each time step ( $i$ ) can be calculated using Equations (6.18) – (6.20) depending on the temperature of the geothermal brine at the inlet of the heat exchanger.

$$60^{\circ}C \leq T_{inb} < 120^{\circ}C \{ P_{ORC}(i) = m_b(i) \cdot c_b \cdot DT(i) \cdot \eta_{ORC}(i) \cdot F_{COOL}(i)/1000 \quad (6.18)$$

$$120^{\circ}C \leq T_{inb} < 140^{\circ}C \{ P_{ORC}(i) = m_b(i) \cdot c_b \cdot DT(i) \cdot \eta_{ORC}^{II}(i)/1000 \quad (6.19)$$

$$140^{\circ}C \leq T_{inb} \{ P_{ORC}(i) = m_b(i) \cdot c_b \cdot DT(i) \cdot \eta_{ORC}^{III}(i)/1000 \quad (6.20)$$

The  $DT$  parameter is user defined (or by default 40°C). This value is however, constrained with the injection temperature, i.e., geothermal brine temperature at the outlet of the heat exchanger  $T_{outb}$  cannot be lower than the set injection temperature  $T_{inj}$ . Namely, following constraint must be satisfied:



$$(T_{inb} - DT) \geq T_{inj} . \quad (6.21)$$

In case this is not satisfied, the  $DT$  is automatically adjusted so that the  $DT = T_{inb} - T_{inj}$ , and  $T_{outb} = T_{inj}$ .

Based on the calculated  $P_{ORC}(i)$  for each time step, the values that can be used as directives for selection of appropriate ORC power plant installed capacity:

- $P_{ORC\_max}$ - maximum value of available ORC power plant production over each of  $T$  time steps,
- $P_{ORC\_min}$  - minimum value of available ORC power plant production over each of  $T$  time steps and
- $P_{ORC\_average}$  - average value of available ORC power plant production over each of  $T$  time steps.

Parameter  $P_{ORC\_max}$  [kW] is obtained by Equation (6. 22):

$$P_{ORC\_max} = \max\{P_{ORC}(i), i \in (1, T)\} . \quad (6.22)$$

Parameter  $P_{ORC\_min}$  [kW] is obtained by Equation (6.23):

$$P_{ORC\_min} = \min\{P_{ORC}(i), i \in (1, T)\} . \quad (6.23)$$

Parameter  $P_{ORC\_average}$  [kW] is obtained by Equation (6.24):

$$P_{ORC\_average} = \text{average}\{P_{ORC}(i), i \in (1, T)\} . \quad (6.24)$$

The user than decides what would be the value for installed capacity of ORC power plant in the range  $P_{ORC\_min} \leq P_{ORC} \leq P_{ORC\_max}$ .

### 6.3.3.2. Electricity production calculation

Once the installed capacity is chosen, the electricity production in each time step can be calculated. Furthermore, when calculating the production, the power plant maintenance period must be considered. Namely, in some percentage of the year, the power plant is not available for production due to maintenance and repair works. For geothermal power plants this is usually around 10% of the year, meaning that the power plant availability is around 90%. In developed evaluation model, the power plant availability can be modelled as percentage of the year ( $ppa$ ) or specific month of maintenance can be defined ( $MoM$ ) when the power plant is not operating. Analogue to the approach in heat production calculation, in case if  $ppa$  is

defined, the production from Equations (6.25) – (6.28) is multiplied by the time when the power plant is available ( $ppa/100\%$ ). In case when  $MoM$  is defined (the power plant is not working the whole month of the year), the production from Equations (6.25) – (6.28) is equal to zero for the whole duration of the month, the rest of the year the production is maximum possible.

Therefore, the electricity production ( $P_{ORC}(i)$ ) for each of  $T$  time steps ( $i$ ) is calculated in [kWh] depending on the temperature of the geothermal brine. Additionally, for each time step it is checked if the possible power plant production is larger than the maximum possible production. If not, the following Equations (6.25) – (6.27) are used:

- if  $P_{ORC}(i) < P_{ORCmax} \forall i, i \in (1, T)$

$$60^{\circ}C \leq T_{inb} < 120^{\circ}C \{ P_{ORC}(i) = m_b(i) \cdot c_b \cdot DT(i) \cdot \eta_{ORC}(i) \cdot F_{COOL}(i)/1000 \quad (6.25)$$

$$120^{\circ}C \leq T_{inb} < 140^{\circ}C \{ P_{ORC}(i) = m_b(i) \cdot c_b \cdot DT(i) \cdot \eta_{ORC}^{II}(i)/1000 \quad (6.26)$$

$$140^{\circ}C \leq T_{inb} \{ P_{ORC}(i) = m_b(i) \cdot c_b \cdot DT(i) \cdot \eta_{ORC}^{III}(i)/1000. \quad (6.27)$$

Otherwise:

- if  $P_{ORC}(i) \geq P_{ORCmax} \forall i, i \in (1, T)$

$$P_{ORC}(i) = P_{ORC,max} \cdot \quad (6.28)$$

Furthermore, the efficiency ( $\eta_{ORC,prod}(i)$  in [%]) of the whole conversion process in this production mode for each of  $T$  time steps ( $i$ ) is calculated using Equation (6.29):

$$\eta_{ORC,prod}(i) = \frac{P_{ORC}(i) \cdot 100 \cdot 1000}{(T_{inb}(i) - T_{outb}(i)) \cdot m_b(i) \cdot c_b} \cdot \quad (6.29)$$

where  $P_{ORC}(i)$  is calculated depending on the conditions of geothermal brine according to Equations (6.25) – (6.28). Additionally, similar as when calculating the heat production, the power plant maintenance period must be considered. The approach is the same as described above in the text in Section 6.3.2.1.

#### 6.3.4. CHP production mode in series configuration

As mentioned in Chapter 2, Section 2.3.3. the geothermal brine is firstly used to produce electricity in the ORC unit. Remaining geothermal energy stored in the geothermal brine at lower temperature is used to produce heat. Series configuration in CHP production is widely used and considered the most common method of cogeneration.

This mode, preferring electricity generation over the heat production, is more complex than previously elaborated only heat production and only electricity production modes. Namely, the system consists of three interconnected fluid circulating loops. The main fluid circulating loop is the hot loop where hot brine flows from an extraction well through pipe system. It first reaches the ORC heat exchanger where brine energy is transferred to the ORC fluid circulating loop and transformed into electricity. The residual geothermal fluid heat energy is available to be transferred by second heat exchanger into useful heat for different means of end use. Output results in this mode can help users to get better assessment of key parameters regarding CHP oriented EGS project development based on the inputs (Figure 6.13).

Because of the configuration and brine flow path, this mode is suitable for sites with higher brine temperature compared to only heat production mode in cases where ORC technology can achieve sustainable efficiency and where there are appropriate conditions for both: i) connection to the power grid and ii) satisfaction of demand from heat consumers in a reachable area.

It must be noted that this mode will not be suitable for heat demand requiring larger heating temperatures due to the brine temperature decrease through ORC heat exchanger and the fact that the same mass flow of geothermal brine is going through ORC and heat demand heat exchangers. Same as for only electricity mode this mode also requires availability of economically and technically feasible connection to power grid.

Main costs in this production mode (neglecting drilling costs) are costs related to ORC loop technology (heat exchanger usually included into the package), heat exchanger for heat demand and also construction of connection to power grid. Same as in only electricity mode losses in connection lines additionally impose negative effects on feasibility of EGS project considering this specific production mode.

Based on inputs on heat demand, available brine temperature, brine mass flow and difference of inlet and outlet brine temperature through ORC heat exchanger, the user is provided with results that give information on potentially available output power from generator in ORC loop and consequently information on potentially unsatisfied heat demand and basic recommendations regarding the heat exchanger for heat demand dimensioning. By changing the difference of inlet and outlet brine temperature through ORC heat exchanger, as dimensioning parameter, user can try to find most satisfying solution and make balance between electricity and heat production. Lowering this temperature difference will surely decrease available net ORC output power but will simultaneously provide geothermal energy

for heat demand with higher temperature. Decreasing temperature difference will have opposite effects.

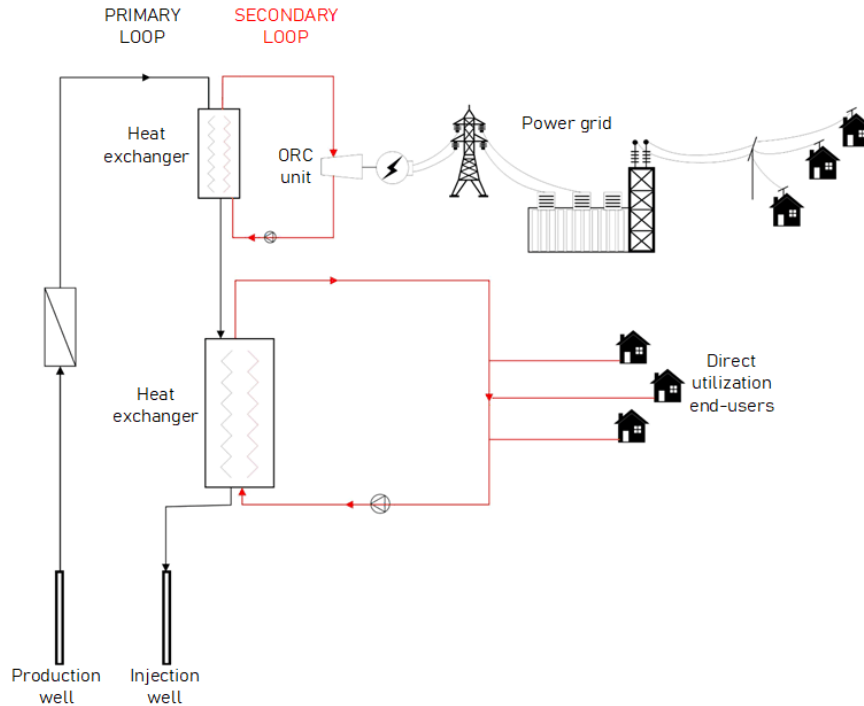

Figure 6.13. CHP production mode series configuration

#### 6.3.4.1. Energy production

For CHP production in series configuration the functional modules developed in Section 6.3.2.1 and Section 6.3.2.2, and Section 6.3.3.1 and Section 6.3.3.2 are used. Namely, firstly the installed capacity of the ORC unit is calculated and selected (as described in Section 6.3.3.1) then the electricity production is calculated (as described in Section 6.3.3.2). These calculations are influenced by couple of constraints. Namely, the geothermal brine temperature at the outlet of the heat exchanger in the ORC part of the CHP plant is constrained by the supply temperature of the heat demand side in the heating power production of the CHP plant (Figure 6.14).

The constraint applied to be able to calculate the energy production in this CHP configuration is as follows:

$$T_{out\_ORC\_b} = \min\{T_{outHD}(i)\} + T_{safe\_margin} , \quad (6.30)$$

where  $\min\{T_{outHD}(i)\}$  represents the minimum supply temperature of the heat demand side, and  $T_{safe\_margin}$  is a safe margin which is by default set to be 3 °C.

This  $T_{out\_ORC\_b}$  is used to adjust the user defined  $DT$ . The rest of the calculations is as described in Section 6.3.3.1 and Section 6.3.3.2.

Secondly, the heat production is calculated with the calculations of the heat exchanger features. The  $T_{out\_ORC\_b}$  is the geothermal brine temperature at inlet of HD heat exchanger. The rest of the calculations is exactly the same as described in Section 6.3.2.1 and Section 6.3.2.2.

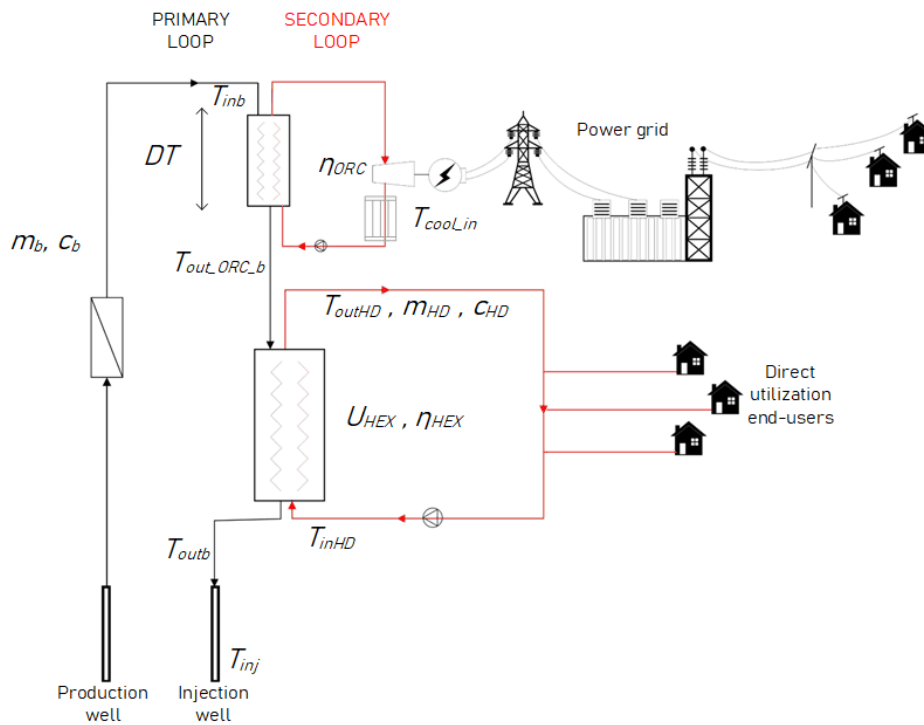

Figure 6.14. CHP production calculation functional module graphical description (series configuration)

### 6.3.5. CHP production mode in parallel configuration

This mode of final energy production assumes that the geothermal brine is used for both heat production and electricity generation at same temperature but different geothermal brine flow rates (as explained in Chapter 2, Section 2.3.3). In comparison to the CHP production in series configuration, this production mode, i.e., system consists of four circulating loops as schematically depicted in Figure 6.15.

Two separate (parallel) hot circulating loops are represented by geothermal fluid loops that flow through pipelines from well to ORC heat exchanger in one loop and to heat exchanger for heat demand in another loop (left part on the Figure 6.15). In ORC heat exchanger part of geothermal heat is transferred to colder organic working fluid that transforms thermal energy to electricity in turbine using Rankine cycle procedure. Condensed and cooled working ORC fluid re-enters ORC heat exchanger where it is preheated and evaporated using heat from geothermal brine. The other part of geothermal heat (with the same temperature as for ORC loop) in geothermal brine is forwarded to heat exchanger for

heat demand in which geothermal energy is transferred to colder circulating loop used for delivery of transferred heat to final heat consumers.

In comparison to CHP production mode in series configuration, part of geothermal brine is used for heat demand and other part, with same temperature but different mass flow, is used for electricity production via ORC loop. Therefore, this production mode can be also labelled as ‘heat demand preferring production mode’. This mode is also suitable for sites with higher available brine temperature compared to only heat production mode when ORC technology can achieve sustainable efficiency and there are appropriate conditions for both connection to power grid and satisfaction of demand from heat consumers in reachable area. In contrast to CHP in series configuration production mode this mode will be suitable for heat demand requiring higher heating temperatures.

Main costs in this production mode (neglecting drilling costs) are costs related to ORC loop related technology (heat exchanger usually included into the package), heat exchanger for heat demand and also construction of connection to power grid. Same as in only electricity mode losses in connection lines additionally impose negative effects on feasibility of EGS project considering this specific production mode.

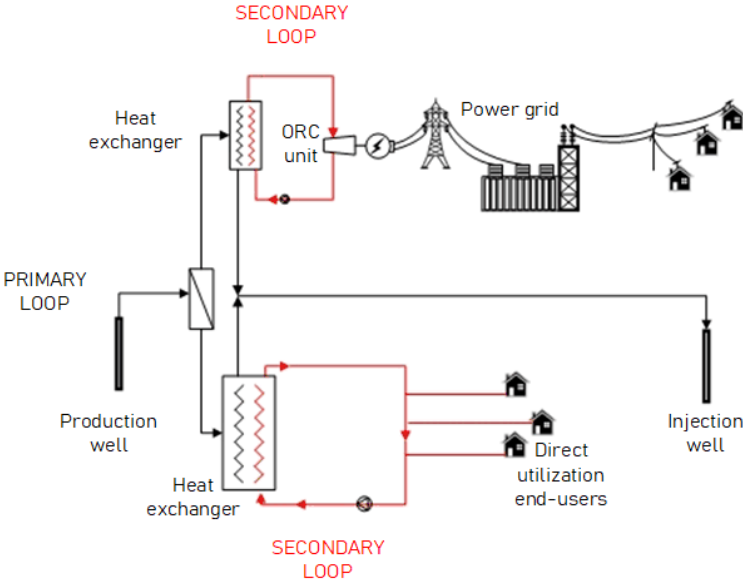

Figure 6.15. CHP production mode parallel configuration

Based on inputs on heat demand, available brine temperature, brine mass flow and difference of inlet and outlet brine temperature through ORC heat exchanger the user is provided with results that give information on potentially unsatisfied heat demand and basic recommendations regarding heat exchanger for heat demand dimensioning and consequently information on potentially available output power from generator in ORC loop. This production mode is very sensitive to protentional seasonal character of heat demand. Namely,

if for example there is a large heat demand for district heating during the winter season and low or neglectable heat demand for district heating during summer season, the available brine mass flow and thermal energy for ORC loop will also vary based on this seasonal character. In this case the user is able to decide on final ORC installed capacity based on pre-calculation with results on minimum, maximum and average available ORC unit installed power. If ORC nominal power is based on maximum available power (in summer season), the capacity utilization factor of ORC power plant will be expectably low and therefore expected LCOE will be relatively high. On the other hand, if ORC nominal power is based on minimum available power (that in winter season), the capacity utilization factor of ORC power plant will be almost 100%, but in this case, there is potentially too much thermal energy thrown away. In these situations, the evaluation model user can check several options for nominal installed capacity of ORC power plant and decide on that with best overall economics and other indicators.

#### 6.3.5.1. Energy production

Special functional module was developed to calculate the production of energy in the CHP power plant with parallel configuration. Figure 6.16 depicts the main input parameters relevant for this module and calculations of energy production:

- $U_{HEX}$  - overall heat transfer coefficient of heat exchanger, in  $[W/m^2K]$ ,
- $c_{HD}$  - heat demand fluid specific heat capacity, in  $[J/kg K]$ ,
- $c_b$  - geothermal brine specific heat capacity, in  $[J/kg K]$ ,
- $m_{HD}$  - heat demand fluid mass flow, in  $[kg/s]$ ,
- $m_b$  – total geothermal brine mass flow, in  $[kg/s]$ ,
- $m_{bORC}$ - geothermal brine mass flow used in ORC power plant as function of T, in  $[kg/s]$ ,
- $m_{bHD}$  - geothermal brine mass flow used for heat demand as function of T, in  $[kg/s]$ ,
- $T_{inb}$  - geothermal brine temperature at inlet of HD heat exchanger, in  $[^{\circ}C]$ ,
- $T_{outb\_HEX\_HD}$  - geothermal brine temperature at outlet of HD heat exchanger, in  $[^{\circ}C]$ ,
- $T_{outb\_HEX\_ORC}$  - geothermal brine temperature at outlet of ORC heat exchanger, in  $[^{\circ}C]$ ,
- $T_{inj}$ - geothermal brine injection temperature in  $[^{\circ}C]$ ,

- $T_{inHD}$  - heating fluid temperature at inlet of HD heat exchanger, in [°C],
- $T_{outHD}$  - heating fluid temperature at outlet of HD heat exchanger, in [°C],
- $\eta_{HEX}$  - heat exchanger heat loss coefficient, in [%] and
- $T_0$  - dead state temperature, in [°C].

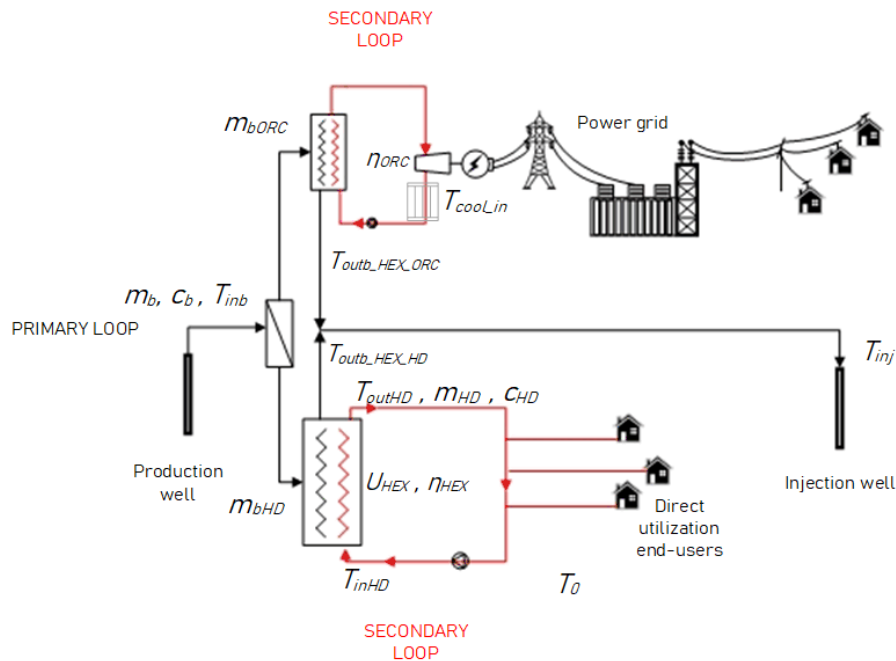

Figure 6.16. CHP production calculation functional module graphical description (parallel configuration)

The energy production calculation in this parallel configuration can be summarized in three main steps as follows:

- 1) Calculating the possible heat production and HD heat exchanger features.
- 2) Calculating the geothermal brine flow available for the ORC branch.
- 3) Calculating the available ORC power plant installed capacity and consequently the electricity production.

As part of the summarized steps certain constraints are imposed. Namely, as in case of calculations in heat production module, there are couple constraints in this module which are used to represent realistic heat transfer in heat demand part of the CHP power plant. In case one of these constraints is not achieved, the module prompts an error, and consequently certain input parameters must be adjusted so that the calculations of energy production can continue. Additionally, the geothermal brine temperature at outlet of HD heat exchanger,  $T_{outb\_HEX\_HD}$ , must be greater than or equal to the injection temperature,  $T_{inj}$ . Namely, if the  $T_{outb\_HEX\_HD}$  is lower than the  $T_{inj}$  it means that ‘too much heat’ was extracted from the geothermal brine in the HD branch for heat demand satisfaction. However, injection temperature is fixed parameter, and it should not change to ensure long-term productivity of



the reservoir. Therefore, if this constraint is violated, the  $T_{outb\_HEX\_HD}$  is set to be equal to the  $T_{inj}$  which generally means that some of the heat demand at some time steps ( $i$ ) will not be satisfied.

Constraints for the heat production:

- $T_{inHD}$  must be greater than  $T_0$ .
- $T_{inb}$  must be greater than  $T_{outHD}$ .
- $T_{outb\_HEX\_HD}$  must be greater than or equal to  $T_{inj}$ .

Next, it must be checked if the temperature of the mixture geothermal fluid  $T_{mix}$  is higher than the injection temperature  $T_{inj}$ . Namely, if the geothermal brine temperature, after the brine from the ORC branch and from the HD branch are mixed, is lower than the injection temperature, it means that ‘too much heat’ was extracted from the geothermal brine to satisfy the heat demand and to produce electricity. However, the injection temperature is fixed parameter important for the proper reservoir management. Namely, it is not sustainable to inject the fluid of temperatures beneath the one that enables long-time usage of the reservoir and available stored heat. Therefore, firstly the production of electricity is adjusted. If the temperature of the adjusted mixture of geothermal brine is still lower than the injection temperature, then the heat production must also be adjusted. Namely, in some time steps it can happen that no electricity is produced, and that some extent of heat demand is not satisfied due to this constraint.

Constraint regarding the injection temperature  $T_{inj}$ :

- $T_{mix}$  must be greater or equal to  $T_{inj}$ ,

where the  $T_{mix}$  represents the temperature of the mixed fluid, i.e., when the geothermal fluid from ORC and HD branches is mixed and injected in the injection well(s). The  $T_{mix}$  is calculated using the Richmann’s rule of mixing [312], as shown in Equation (6.31):

$$T_{mix} = \frac{\sum_{i=1}^n \dot{m}_i \cdot c_i \cdot T_i}{\sum_{i=1}^n \dot{m}_i \cdot c_i}, \quad (6.31)$$

where the  $T$  represents the fluid’s temperature [°C],  $\dot{m}$  is the mass flow [kg/s],  $c$  is the specific heat capacity [J/kg°C] of the geothermal fluid from each branch, and  $n$  is the number of branches. In this case the Equation (6.31) can be written:

$$T_{mix} = \frac{m_{bHD} \cdot T_{outb\_HEX\_HD} \cdot c_{bHD} + m_{bORC} \cdot T_{outb\_HEX\_ORC} \cdot c_{bORC}}{m_{bHD} \cdot c_{bHD} + m_{bORC} \cdot c_{bORC}}. \quad (6.32)$$

In the calculations of  $T_{mix}$ , a simplification is used assuming that  $c_{bHD} = c_{bORC} = c_b$ .

In the first step of energy production, i.e., to calculate the possible heat production, firstly the part of the geothermal brine mass flow that is used in the HD branch to satisfy the heat demand for each  $T$  time steps ( $i$ ) is calculated in [kg/s] as shown in Equation (6.33):

$$m_{bHD}(i) = \frac{m_{HD}(i) \cdot c_{HD}}{\eta_{HEX} \cdot c_b} . \quad (6.33)$$

In Equation (6.33) it is assumed that the temperature difference between HD heat exchanger outlet temperature of the geothermal brine,  $T_{outb\_HEX\_HD}$ , and inlet temperature of heat demand stream,  $T_{inHD}$ , is same as the temperature difference between HD heat exchanger inlet temperature of brine,  $T_{inb}$ , and outlet temperature of heat demand stream,  $T_{outHD}$  for each of  $T$  time steps ( $i$ ) as shown in Equation (6.34):

$$T_{outb\_HEX\_HD} - T_{inHD} = T_{inb} - T_{outHD} . \quad (6.34)$$

Additionally, if calculated  $m_{bHD}(i) > m_b(i)$  it means that the heat demand in time step ( $i$ ) cannot be satisfied with the designed CHP system. Therefore, in this time step ( $i$ ) the brine mass flow in the HD branch is set to be equal to the total brine mass flow, i.e.,  $m_{bHD}(i) = m_b(i)$ , and the mass flow for the ORC branch is set to zero.

Heat demand that could be satisfied for each  $T$  time steps ( $i$ ) is calculated in [kWh] using Equation (6.35):

$$HD_S(i) = \frac{\left(T_{inb}(i) - T_{outb\_HEX\_HD}(i)\right) \cdot m_{bHD}(i) \cdot c_b \cdot \eta_{HEX}}{1000} . \quad (6.35)$$

Additionally, the time step in evaluation model is set to be one month, therefore the heat demand that can be satisfied as calculated with Equation (6.35) must be multiplied by 730 (average number of hours in one month). Additionally, when calculating the production, the power plant maintenance period must be considered. Same as when the heat is calculated in Section 6.3.2.1., in case if power plant availability ( $ppa$ ) parameter is defined, the production from Equation (6.35) is multiplied by the time when the power plant is available ( $ppa/100\%$ ). In case when month of maintenance ( $MoM$ ) is defined (the power plant is not working the whole month of the year), the production from Equation (6.35) is equal to zero for the whole duration of the month, the rest of the year the production is maximum possible.

Heat fluid mass flow ( $m_{HDS}(i)$ ) that can be satisfied for each of  $T$  time steps ( $i$ ) is calculated in [kg/s] using Equation (6.36):

$$m_{HDS}(i) = \frac{(T_{inb}(i) - T_{outb_{HEX_{HD}}}(i)) \cdot m_{b_{HD}}(i) \cdot c_b \cdot \eta_{HEX}}{(T_{out_{HD}}(i) - T_{in_{HD}}(i)) \cdot c_{HD}}. \quad (6.36)$$

In cases when  $m_{HDS}(i)$  is lower than the required heat demand fluid mass flow  $m_{HD}(i)$ , a warning message is issued stating that in those time steps the heat demand could not completely satisfied.

Now that mass flows and possible produced energy are calculated, the suggested heat exchanger features are calculated as presented in Section 6.3.2.2.

Second step is to calculate the geothermal brine flow available for the ORC branch for each time step ( $i$ ). This part of the brine mass flow  $m_{b_{ORC}}$  is calculated in [kg/s] using the Equation (6.37):

$$m_{b_{ORC}}(i) = m_b(i) - m_{b_{HD}}(i). \quad (6.37)$$

As mentioned above, this brine mass flow can be  $m_{b_{ORC}}(i) \geq 0$  depending on the HD branch, and constraint regarding  $T_{mix}$  (calculated according to Equation 6.43 and constraint is that the  $T_{mix}$  must be greater of equal to  $T_{inj}$ ).

The third step is to calculate the possible ORC unit installed power and consequently the produced electricity. Firstly, for each time step ( $i$ ) the geothermal brine temperature at the outlet of the heat exchanger is calculated as:

$$T_{outb_{HEX_{ORC}}}(i) = T_{inb}(i) - DT(i), \quad (6.38)$$

Where  $DT(i)$  is user defined parameter. This calculated  $T_{outb_{HEX_{ORC}}}(i)$  is additionally used to check the constraint regarding the  $T_{mix}$  (calculated according to Equation 6.43 and constraint is that the  $T_{mix}$  must be greater of equal to  $T_{inj}$ ). If this constraint is not satisfied for some time step ( $i$ ),  $T_{outb_{HEX_{ORC}}}(i)$  is newly calculated, i.e., adjusted so that the constraint is satisfied. Additionally, in that case the  $DT(i)$  is also adjusted and calculated as:

$$DT_{new}(i) = T_{inb}(i) - T_{mix}(i) \quad \text{where} \quad T_{mix}(i) = T_{inj}. \quad (6.39)$$

From this point, the calculations of the possible installed power of the ORC unit and electricity production is calculated as described in Section 6.3.3.1 and Section 6.3.3.2.

### 6.4. FINANCIAL ANALYSIS

Once the EGS project has been sized, and all performance metrics have been calculated (e.g., installed capacities and energy production quantities), the financial analysis is used to calculate all cash flows throughout the project’s lifetime which consist of all investment costs, O&M costs, gained revenues, realized subsidies and incentives, etc. The results are also main economic indices usually used to assess the economic feasibility of certain project. These include calculation of NPV, LCOE, and IRR. All costs are either user inputs or are calculated/estimated using the pre-defined default costs correlation functions that are incorporated in the evaluation model. These costs should be as accurate and credible as possible since they affect the abovementioned main economic output parameters.

Each component of the financial analysis is explained in the following Sections 6.4.1 - 6.4.3. Additionally, main output parameters, i.e., results of the financial analysis are explained and described in Section 6.4.4 and Section 6.4.5.

The financial analysis methodology used in the evaluation model is the Discounted Cash Flow (DCF) method. Only cash inflows and outflows are considered in this financial analysis. An appropriate real discount rate is adopted (default or user defined and calculated based on the discount rate and inflation rate) in order to calculate the present value of the future cash flows.

Financial analysis in the evaluation model is carried out in 3 main steps:

1. Calculating the Net present value on investment (NPV(C)) and Internal rate of return on investment (IRR(C));
2. Calculating the financial sustainability; and
3. Calculating the Net present value on capital (NPV(K)) and Internal rate of return on capital (IRR(K)).

The structure of the financial analysis and input data included in each step is depicted in Figure 6.17.

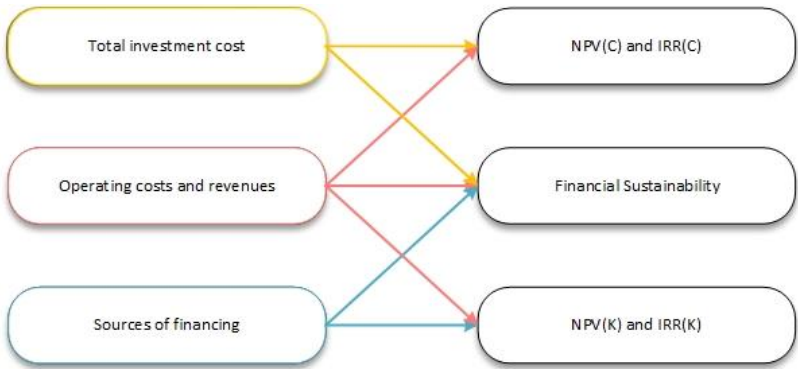

Figure 6.17. Structure of financial analysis in evaluation model

First step in the financial analysis is the calculation of all investment costs.

Investment costs include:

- Capital costs of all fixed assets – surface equipment costs, gathering systems costs, grid connection costs, and other equipment cost;
- Capital costs of start-up costs – permitting costs, exploration costs and drilling costs;
- Replacement costs - includes costs occurring during the reference period to replace short-life machinery and/or equipment; and
- Residual value – of the fixed investment should be included within these costs for the end-year. It will be zero or negligible if a time horizon equal to the economic lifetime of the asset has been selected. This residual value is for now in the tool considered to be zero.

The second step in the financial analysis is the calculation of the total operating costs and revenues. Operating costs include all the cost to operate and maintain (O&M) the system. In the evaluation model following O&M costs are foreseen:

- Annual labour costs;
- Annual well field maintenance costs; and
- Annual power plant maintenance costs.

Project revenues are defined as the monetary benefits obtained from the electricity and/or heat market sales.

The next step is the identification of the different sources of financing that cover the investment costs. The main sources anticipated in the evaluation model are:

- Private capital (equity and loans, loan-equity ratio);
- Community assistance (the EU grant);
- National public contribution (grants or capital subsidies at central, regional and local government level); and
- Other resources (loans from other lenders, etc.).

Here the loan is a financial inflow and is treated as a financial resource coming from third parties.

Each component of the financial analysis is explained in the following Sections 6.4.1 - 6.4.3. Additionally, main output parameters, i.e., results of the financial analysis are explained and described in Section 6.4.4 and Section 6.4.5.

### 6.4.1. Capital costs

Capital costs are estimated/calculated for the following phases of the project development (Figure 6.18):

- Exploration and permitting activities;
- Well field completion activities;
- Field gathering system for geothermal brine; and
- Power plant/energy facility construction activities.

Capital costs are either based on the implemented default cost correlations or are direct user inputs. Each phase represents part of total capital costs for a certain project and capital costs are both those costs occurring prior to the start of the operational phase and those costs incurred once the operational phase begins. Those costs that incur in the operational phase are associated with production/injection pump replacement costs. Additionally, the evaluation model assumes that the costs for abovementioned activities that occur in each development phase (permitting, exploration, drilling, power plant construction) are spread evenly over the duration identified for each phase. Meaning that, if for example the duration of exploration phase is two years, all costs related to this phase are spread 50% in the first year and 50% in the second year of the exploration phase.

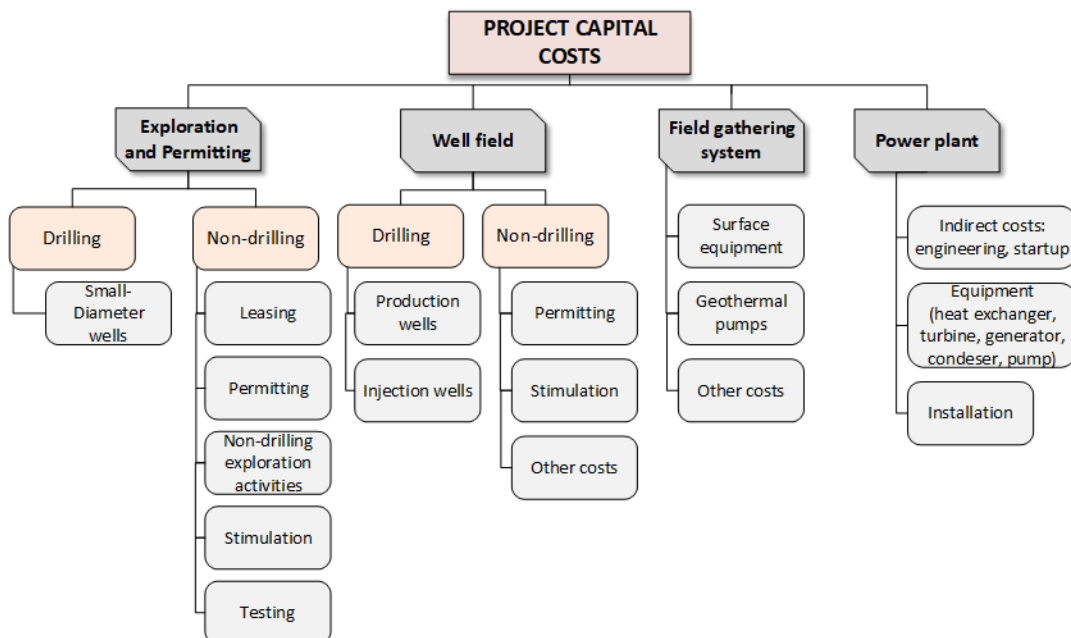

Figure 6.18. Project capital cost included in the financial analysis

Default cost correlations are thoroughly described in following Sections 6.4.1.1 - 6.4.1.7. Those default correlations can be used to estimate different type of capital cost in case if the user does not have the cost data on disposal.

#### 6.4.1.1. Permitting costs correlations

This function calculates the default costs for activities related to the permitting phase. The default data are used from GETEM model [174] and adjusted to recent expenses. Namely, the year 2020, which was the last year pre-covid period and pre-Ukrainian-Russian war was taken to be ‘recent year’. The costs in this phase include:

- Pre-drilling activities costs;
- Small-diameter wells (early drilling) drilling costs; and
- Land utilization permit costs,

Pre-drilling activities costs are calculated according to Equation (6.40):

$$C_{pre\text{-}drilling\ activities}^{permitting} = 50,000 \cdot \frac{PPI_{2020}}{PPI_{2012}} \cdot er_{2020} \cdot \quad (6.40)$$

Early drilling costs are calculated according to the Equation (6.41):

$$C_{early\ drilling}^{permitting} = 250,000 \cdot \frac{PPI_{2020}}{PPI_{2012}} \cdot er_{2020} \cdot \quad (6.41)$$

Utilization permit costs are calculated according to Equation (6.42):

$$C_{utilization\ permit}^{permitting} = 500,000 \cdot \frac{PPI_{2020}}{PPI_{2012}} \cdot er_{2020} \cdot \quad (6.42)$$

In the Equations (6.40) – (6.42) the  $PPI_{2020}/PPI_{2012}$  is the ratio of PPI (Producer Price Index) indexes for these activities for the year 2020 and 2012 because the base correlations are adjusted to the  $PPI_{2012}$ . Namely, to translate the default costs (from base year 2012) to the ‘recent year’ 2020, cost indexes are used. Hence, generally the costs in the ‘recent year’ can be calculated as shown in Equation (6.43):

$$\frac{C_{base\_year}}{C_{recent\_year}} = \frac{INDEX_{base\_year}}{INDEX_{recent\_year}} \cdot \quad (6.43)$$

The ratio  $PPI_{2020}/PPI_{2012}$  in evaluation model for all activities in permitting phase is 1.281. Additionally, the used exchange rate  $er_{2020}$  is the average exchange rate for year 2020 which was 0.877.

Total costs of the permitting phase (in [€]) are represented as sum of cost calculated with Equations (6.40) – (6.42) taking also into account the number of sites ( $n_{sites}^{permitting}$ ) considers in this phase (by default this number is set to be 1) (Equation 6.44). User can overwrite all this default calculated values.

$$C_{TOTAL}^{permitting} = C_{pre-drilling activities}^{permitting} \cdot n_{sites}^{permitting} + C_{early drilling}^{permitting} \cdot n_{sites}^{permitting} + C_{utilization permit}^{permitting} \cdot n_{sites}^{permitting} \quad (6.44)$$

#### 6.4.1.2. Exploration costs correlations

This function calculates the default costs for activities related to the exploration phase. The default data are used from GETEM model [174] and adjusted to recent expenses. The costs include:

- Pre-drilling costs;
- Explorational drilling costs;
- Leasing costs; and
- Additional costs.

Pre-drilling costs are calculated according to Equation (6.45):

$$C_{pre-drilling}^{exploration} = 250,000 \cdot \frac{PPI_{2020}}{PPI_{2012}} \cdot er_{2020} \quad (6.45)$$

The ratio  $PPI_{2020}/PPI_{2012}$  for pre-drilling costs is 0.917.

Explorational drilling costs are calculated according to the Equation (6.46):

$$C_{explorational drilling}^{exploration} = 1,230,000 \cdot \frac{PPI_{2020}}{PPI_{2012}} \cdot er_{2020} \quad (6.46)$$

The ratio  $PPI_{2020}/PPI_{2012}$  for explorational drilling costs is 0.780.

Leasing costs are calculated according to Equation (6.47) and include generally the costs to be paid for utilization of certain land are for geothermal purposes:

$$C_{leasing}^{exploration} = 6096.3 \cdot n_{wells} \cdot \frac{PPI_{2020}}{PPI_{2012}} \cdot er_{2020} \quad (6.47)$$

where  $n_{wells}$  is the total number of wells foreseen to be drilled in drilling phase (production and injection wells). The ratio  $PPI_{2020}/PPI_{2012}$  for leasing costs is 0.9105.

Any additional costs are calculated according to Equation (6.48) and represent by default 5% of costs for the costs calculated in Equations (6.45) – (6.47):

$$C_{additional}^{exploration} = 0.05 \cdot (C_{pre-drilling}^{exploration} + C_{explorational drilling}^{exploration} + C_{leasing}^{exploration}) \quad (6.48)$$

The used exchange rate  $er_{2020}$  is the average exchange rate for year 2020 which was 0.877.



Total costs of the permitting phase (in [€]) are represented as sum of cost calculated with Equations (6.45) – (6.48) taking also into account the number of sites ( $n_{sites}^{exploration}$ ) considers in this phase (by default this number is set to be 1) (Equation 6.49). User can overwrite all this default calculated values.

$$C_{TOTAL}^{exploration} = C_{pre-drilling}^{exploration} \cdot n_{sites}^{exploration} + C_{explorational\ drilling}^{exploration} \cdot n_{sites}^{exploration} + C_{leasing}^{exploration} + C_{additional}^{exploration} . \quad (6.49)$$

#### 6.4.1.3. Drilling costs correlations

This function calculates the average geothermal well drilling costs. According to [173] the average costs of geothermal wells can be reasonably well approximated by Equation (6.50) with a correlation coefficient  $R^2$  of 0.92. Namely, the approximation of drilling costs per well presented in Equation (6.50), calculated in millions of euros, is based on the data for geothermal well cost records from 2008-2013 and from WellCost model predictions for EGS wells.

$$C_{well}^{drilling} = (1.72 \cdot 10^{-7} \cdot MD^2 + 2.3 \cdot 10^{-3} \cdot MD - 0.62) \cdot \frac{PPI_{2020}}{PPI_{2014}} \cdot er_{2020} , \quad (6.50)$$

where  $MD$  is the measured depth of the well. The ratio  $PPI_{2020}/PPI_{2012}$  for drilling is 1.139. Furthermore, the correlation in Equation (6.50) is used to calculated costs for both production and injection well(s).

Furthermore, since the EGS systems are created by different stimulation techniques, that enable the increase of the permeability, the costs of stimulation must also be considered. Therefore, the stimulation costs per well are calculated according to Equation (6.51), in [€]:

$$C_{stimulation}^{drilling} = 2,500,000 \cdot \frac{PPI_{2020}}{PPI_{2014}} \cdot er_{2020} . \quad (6.51)$$

The ratio  $PPI_{2020}/PPI_{2012}$  for drilling costs is 0.773.

The exchange rate  $er_{2020}$  used in Equation (6.50) and Equation (6.51) is the average exchange rate for year 2020 which was 0.877.

Total costs of drilling phase (in [€]) are calculated as the sum of costs calculated in Equation (6.50) and Equation (6.51). The number of drilled production and injection wells must be taken into account. Additionally, any additional costs not covered with the costs

calculated in Equation (6.50) and Equation (6.51) are also added to the total costs of drilling phase as shown in Equation (6.52).

$$C_{TOTAL}^{drilling} = (C_{well}^{drilling} \cdot n_{production_{well}} + C_{well}^{drilling} \cdot n_{injection_{well}}) \cdot 10^6 + C_{stimulation}^{drilling} + C_{additional}^{drilling} \cdot \quad (6.52)$$

#### 6.4.1.4. Pumping systems costs correlations

Considering an EGS system, the pumping systems refer to the production and injection pumps. Namely, depending on the EGS design and conditions, all projects are using production pumps to obtain valid geothermal fluid circulation in the primary loop. Furthermore, injection pumps are used to increase the pressure across the reservoir. Namely, the pressure at the inflow to the reservoir (injection well) must be limited to prevent unwanted growth of the reservoir and leakage of the geothermal fluid out of the reservoir. This pressure has already been ‘maximized’ at the power plant in Soulz-sous-Forest and other EGS projects [172]. Two kinds of artificial lift are applicable to geothermal systems: line shaft pumps and electrical submersible pumps (ESP). Line shaft pumps work at lower flow rates and pump set depths than ESPs. Thus, ESPs have higher potential for aiding in reaching EGS economic flow rates. Therefore, the ESP pump is modelled for the production pump.

The function calculating the default ESP production pump costs is based on the pump power and the depth of the installation of the pump. Furthermore, the total production pump costs consist of ESP pump cost, pump installation cost, and other installation costs such as casing etc. The default coefficients of costs for the production pump are taken from the GETEM model [174] and are adjusted to the year 2020 using the already mentioned PPI indexes.

Production pump costs are calculated in [€] according to the Equation (6.53):

$$C_{production_{pump}} = 1,750 \cdot (1.34102 \cdot P_{pump})^{0.7} \cdot \frac{PPI_{2020}}{PPI_{2014}} \cdot er_{2020}, \quad (6.53)$$

where  $P_{pump}$  is the pump power in [kW], and the ratio  $PPI_{2020}/PPI_{2012}$  is equal to 1.605.

Production pump installation costs are calculated in [€] according to Equation (6.54):

$$C_{production_{pump}}^{installation} = (195.66 \cdot depth + 9.620) \cdot er_{2020}, \quad (6.54)$$

where  $depth$  is the installation depth of the production pump measured in [m]. The coefficients in Equation (6.54) are designed to account for the working hours to install the

pump [\$], the costs for the casing [\$/m] and specific costs of the installation [\$/m] and the ratio  $PPI_{2020}/PPI_{2012}$ .

Other installation costs are calculated in [€] according to Equation (6.54):

$$C_{production_{pump}}^{other} = 5,750 \cdot (1.34102 \cdot P_{pump})^{0.2} \cdot \frac{PPI_{2020}}{PPI_{2014}} \cdot er_{2020}, \quad (6.55)$$

where  $P_{pump}$  is the pump power in [kW], and the ratio  $PPI_{2020}/PPI_{2012}$  is equal to 1.605.

Total production pump costs are represented by the sum of costs calculated in Equations (6.53) – (6.55) as shown in Equation (6.56):

$$C_{TOTAL}^{production_{pump}} = C_{production_{pump}} + C_{production_{pump}}^{installation} + C_{production_{pump}}^{other}. \quad (6.56)$$

The calculation of default cost for injection pump are based on the real data set from the power plant in Rittershoffen, France and by using the six-tenth rule [313]. The rule of six-tenth rule that was developed over years gives very satisfactory results when only an approximate cost within plus or minus 20% is required. Therefore, at any rate the following Equation (6.57) expresses the rule of six-tenth:

$$C_B = C_A \cdot \left(\frac{S_B}{S_A}\right)^{0.6}, \quad (6.57)$$

where  $C_B$  is the approximate cost of equipment size  $S_B$ ,  $C_A$  is the known cost of equipment having corresponding size  $S_A$  (in same unit as  $S_B$ ), the ratio  $S_A/S_B$  is know as the site factor. Based on this the costs of injection pump are calculated in (€) according to Equation (6.58):

$$C_{injection_{pump}} = 60,000 \cdot \left(\frac{P_{injection_{pump}}}{250}\right)^{0.6}, \quad (6.58)$$

where  $P_{injection_{pump}}$  is the calculated power of injection pump (in [kW]) or inserted value by the user.

#### 6.4.1.5. Power plant equipment costs correlations

Functional module for calculating power plant equipment costs was developed. The used costs correlations and functions were modelled after [314]–[317]. Namely, purchase power plant equipment costs are calculated according to Table 6.2.

Table 6.2. Correlations and references used to model power plant equipment cost correlations

Reference		
[314]	$C_E = C_B \cdot \left(\frac{Q}{Q_B}\right)^M$	(6.59)
[315]	$C_E = a + b \cdot S^n$	(6.60)
[316]	$\log_{10} C_E = K_1 + K_2 \cdot \log_{10} A + K_3 \cdot (\log_{10} A)^2$	(6.61)
[317]	$C_E = 1,850,000 \cdot \left(\frac{P}{11,800}\right)^{0.94}$	(6.62)

Approximation shown in Equation (6.59) is used to calculate costs of centrifugal pump in case of only electricity production mode and CHP production mode.

Approximation shown in Equation (6.60) is used to calculate costs of heat exchangers (shell and tube with single shell pass and counter-flow) for both heat production and electricity production modes, condenser (either air-cooled or wet cooling tower) in cases when ORC unit is used for electricity production (only electricity production mode and CHP mode), and turbine (for installed power larger than 100 kW) in case of only electricity production mode and CHP production mode.

Approximation shown in Equation (6.61) is used to calculate costs of turbine (for installed power ranging  $70 \text{ kW} \leq P_{ORC} \leq 100 \text{ kW}$ ) in case of only electricity production mode and CHP production mode.

Approximation shown in Equation (6.62) is used to calculate the costs of generator in case of only electricity production mode and CHP production mode.

Additionally, the cost indexes had to be defined and are used to bring the costs up-to date as shown in Equation (6.43). Here, the Chemical Engineering Plant Cost Indexes (CEPCI) are used since they are commonly used and particularly useful [314]. The used indexes are shown in Table 6.3. Furthermore, since all costs correlation in Equation (6.63) – Equation (6.70) are initially expressed in U.S. dollars, the average exchange rate,  $er_{2020}$ , for the year 2020 was used to obtain the costs in euros.

Table 6.3. CEPCI cost indexes used in the calculation of default costs of power plant equipment

Index	Value	Reference
<i>INDEX1_EQ_a</i>	435.8	[314]
<i>INDEX1_EQ_b</i>	532.9	[315]
<i>INDEX1_EQ_c</i>	397.0	[316]

---

$$INDEX1\_EQ\_d \quad 359.2 \quad [317]$$

$$INDEX2\_EQ \quad 753.3 \quad [314]$$

---

Based on the abovementioned the costs for turbine are calculated based on the installed capacity and according to Equation (6.63):

$$\begin{aligned} & \text{for } 70 \text{ kW} \leq P_{ORC} \leq 100 \text{ kW} \\ C_{turbine} &= 10^{(2.6259+1.4398 \cdot \log_{10} P_{ORC} - 0.1798 \cdot \log_{10}(P_{ORC}^2))} \cdot er_{2020} \cdot \left( \frac{INDEX2\_EQ}{INDEX1\_EQ\_c} \right) \end{aligned} \quad (6.63)$$

$$\begin{aligned} & \text{for } 100 \text{ kW} < P_{ORC} \leq 20,000 \text{ kW} \\ C_{turbine} &= (-14,000 + 1,900 \cdot (P_{ORC})^{0.75}) \cdot er_{2020} \cdot \left( \frac{INDEX2\_EQ}{INDEX1\_EQ_b} \right), \end{aligned} \quad (6.64)$$

where  $P_{ORC}$  is the installed capacity of the power plant in [kW]. It must be noted that for ORC installed power less than 70 kW and greater than 20 MW related turbine costs must be directly inserted by the user.

The generator costs are calculated based on the installed capacity of the ORC unit and according to Equation (6.65):

$$C_{generator} = 1,850,000 \cdot \left( \frac{P_{ORC}}{11,800} \right)^{0.94} \cdot er_{2020} \cdot \left( \frac{INDEX2\_EQ}{INDEX1\_EQ_d} \right). \quad (6.65)$$

Calculating the heat exchanger (shell & tube with single shell pass, counter-flow) costs for heat production model is done based on the area of the heat exchanger and is done according to Equation (6.66):

$$\begin{aligned} & \text{for } 10 \text{ m}^2 \leq HEX_{Area} < 80 \text{ m}^2 \\ C_{HEX} &= (2.8 \cdot 10^4 + 54 \cdot (Area_{HEX})^{1.2}) \cdot er_{2020} \cdot \left( \frac{INDEX2\_EQ}{INDEX1\_EQ_b} \right) \end{aligned} \quad (6.66)$$

$$\begin{aligned} & \text{for } 80 \text{ m}^2 \leq HEX_{Area} \leq 4000 \text{ m}^2 \\ C_{HEX} &= \left( 3.28 \cdot 10^4 \cdot \left( \frac{Area_{HEX}}{80} \right)^{0.68} \right) \cdot er_{2020} \cdot \left( \frac{INDEX2\_EQ}{INDEX1\_EQ_a} \right). \end{aligned} \quad (6.67)$$

It must be noted that for the heat exchanger area less than 10 m<sup>2</sup> and greater than 4,000 m<sup>2</sup> related HEX costs must be directly inserted.

The costs of heat exchanger for electricity production in the ORC unit are calculated according to Equation (6.68):

$$C_{HEX\_ORC} = (16.75 \cdot P_{ORC} + 2,250) \cdot er_{2020} \quad (6.68)$$

In cases when the electricity is produced, calculating the centrifugal pump (including motor) costs is done based on the installed power of the pump,  $P_{Pump}$  and according to Equation (6.69). The presented costs correlation function is applicable for pump costs when the pump power is:  $4 \text{ kW} \leq P_{Pump} \leq 700 \text{ kW}$ , for pump powers outside the range, the cost must be directly inserted.

$$C_{pumpcent} = \left( 9.84 \cdot 10^3 \cdot \left( \frac{P_{Pump}}{4} \right)^{0.55} \right) \cdot er_{2020} \cdot \left( \frac{INDEX2\_EQ}{INDEX1\_EQ\_a} \right) \quad (6.69)$$

In cases when the electricity is produced, if the condenser type is the wet cooling tower (WCT), the costs are based on the flow of the coolant ( $Cool_{flow}$ ), i.e., water and the calculations are done according to Equation (6.70). The Equation (6.70) is applicable for WTC costs when the flow rate of the water as coolant is in the range:  $100 \text{ l/s} \leq Cool_{flow} \leq 10,000 \text{ l/s}$ . For coolant flows outside the range, the cost must be directly inserted.

$$C_{WCT} = \left( 1.7 \cdot 10^5 \cdot 1,500 \cdot (Cool_{flow})^{0.9} \right) \cdot er_{2020} \cdot \left( \frac{INDEX2\_EQ}{INDEX1\_EQ\_b} \right) \quad (6.70)$$

In cases when the electricity is produced, if the condenser type is the air-colling condenser with fan (ACCfan), the costs are based on the power of the ACC fan ( $Cool_{power}$ ) according to Equation (6.71). The correlation from Equation (6.71) is applicable for the power of ACC fan in the range:  $50 \text{ kW} \leq Cool_{power} \leq 200 \text{ kW}$ . For ACC fan powers outside the range, the cost must be directly inserted.

$$C_{ACCfan} = \left( 1.23 \cdot 10^4 \cdot \left( \frac{Cool_{power}}{50} \right)^{0.76} \right) \cdot er_{2020} \cdot \left( \frac{INDEX2\_EQ}{INDEX1\_EQ\_a} \right) \quad (6.71)$$

In cases when the electricity is produced, if the condenser type is the air-colling condenser without a fan (ACC), the costs are based on the area ( $Cool_{Area}$ ) according to Equation (6.72). The correlation from Equation (6.72) is applicable for the power of ACC fan in the range:  $200 \text{ m}^2 \leq Cool_{Area} \leq 2,000 \text{ m}^2$ . For ACC areas outside the range, the cost must be directly inserted.

$$C_{ACC} = \left( C_{eACC} = 1.56 \cdot 10^5 \cdot \left( \frac{Cool_{Area}}{200} \right)^{0.89} \right) \cdot er_{2020} \cdot \left( \frac{INDEX2\_EQ}{INDEX1\_EQ\_a} \right) \quad (6.72)$$

#### 6.4.1.6. Power grid connection conditions and costs

This module is used for assessing technical feasibility of ORC power plant connection to the nearest or most suitable point in power grid based on basic and necessary connection parameters. It is also used for evaluation of related cost of this connection. There are certain technical constraints regarding the possibility of ORC power plant connection to grid. Generally, the nominal voltage of electricity produced from ORC power plant is 0.4 kV. Direct connection to the nearest 0.4 kV power network would be economically the best option, but usually there is no appropriate point in 0.4 kV distribution network in proximity of ORC plant. On such low voltage levels power losses in connection lines and voltage drops on these lines are too high. In this functional module, it is assumed that ORC power plant cannot be connected directly to 0.4 kV network in cases when its installed capacity is higher than 500 kW (usual practice considering requirements of operators of distribution networks). An alternative is to build substation to elevate low voltage to medium voltage (usually to 10 kV, 20 kV, 35kV or 36 kV). The higher secondary voltage levels the lower the losses in connection lines and voltage drops. However, higher voltage levels imply also higher related costs, both for substation construction and cabling. It is clear that costs related to ORC power plant connection to the power network are proportional to installed ORC power capacity and also to the distance from appropriate point of connection.

Module provides an evaluation of following parameters:

- $ST_{cost}$  - connection costs related to construction of substation (if needed), in [€],
- $Cable_{cost}$  - connection costs related to cabling,
- $P_{loss}$  - power losses in connection line, and
- $P_{ORCnet}$  - electricity that can be delivered to the grid and sold to market, net electricity production.

Basic details and parameters that are relevant for this module are following:

- $T$  - number of time steps (months),
- $U_{ORC}$  - voltage level (between two phases) of electricity produced from ORC power plant, in [kV],
- $U_{grid}$  - voltage level (between two phases) of power grid (nearest or most suitable) to which ORC power plant should be connected to, in [kV],
- $P_{ins}$  - installed capacity of ORC power plant, in [kW],
- $Cable_l$  - distance between ORC power plant and nearest connection point to power grid, in [km],

- $Cable_{CS}$  - cable cross-section, in [mm<sup>2</sup>], and
- $P_{ORC}$  – produced electricity from ORC plant as function of T, in [kWh].

An important aspect of connection is the selection of cable parameters that affect its resistance and also connection costs. For example, greater cross-section will imply lower resistance and therefore lower losses but higher costs due to a larger amount of material. Copper is also a better conductor than aluminium, but it is also more expensive. Cable resistance,  $R_C$ , is calculated using Equation (6.73):

$$\begin{aligned} R_C &= 22.4 \cdot \frac{Cable_l}{Cable_{CS}} \text{ for copper,} \\ R_C &= 36.9 \cdot \frac{Cable_l}{Cable_{CS}} \text{ for aluminum.} \end{aligned} \quad (6.73)$$

Power losses through connection cable when there is no substation are calculated in [kWh] for each of  $T$  time steps ( $i$ ) using Equation (6.74):

$$P_{loss}(i) = \frac{P_{ORC}(i)^2 \cdot R_C}{U_{GRID}^2 \cdot 1000}. \quad (6.74)$$

Net electricity that can be delivered to the grid and sold to market when there is no substation needed is calculated in [kWh] for each of  $T$  time steps ( $i$ ) using Equation (6.75):

$$P_{ORCnet}(i) = P_{ORC}(i) - P_{loss}(i). \quad (6.75)$$

Power losses in connection cable when there is substation (power losses in transformer are approximated to 1,5%) are calculated in (kWh) for each of  $T$  time steps ( $i$ ) using Equation (6.76):

$$P_{loss}(i) = \frac{(Prod_{ORC}(i) * 0.985)^2 \cdot R_C}{U_{GRID}^2 \cdot 1000}. \quad (6.76)$$

Net electricity that can be delivered to the grid and sold to market when there is substation (power losses in transformer are approximated to 1.5%) is calculated in [kWh] for each of  $T$  time steps ( $i$ ) using Equation (6.77):

$$P_{ORCnet}(i) = P_{ORC}(i) \cdot 0.985 - P_{loss}(i). \quad (6.77)$$

Now, the electrical current through connection cable,  $I_{GRID}$ , is calculated in (A) for each of  $T$  time steps ( $i$ ) using Equation (6.78):



$$I_{GRID}(i) = \frac{\sqrt{3} \cdot P_{ORCnet}(i)}{U_{GRID}} . \quad (6.78)$$

The voltage drop on connection cable,  $D_V$ , is calculated in (V) for each of  $T$  time steps ( $i$ ) using Equation (6.79):

$$D_V(i) = I_{GRID}(i) \cdot R_C . \quad (6.79)$$

Equation (6.80) is used to check if the voltage drop on connection cable is within 10% of nominal voltage of power network for each  $T$  time steps ( $i$ ). If this constraint is violated, the user is alerted that the specified cable is not convenient, therefore a cable of larger cross section should be used.

$$D_V(i) < 0.1 \cdot \frac{U_{GRID} \cdot 1000}{\sqrt{3}} . \quad (6.80)$$

After this constraint from Equation (6.80) is checked and the chosen and modelled cable is suitable for the connection of the power plant to the existing grid, the cost can be calculated. The connection costs include the costs for the substation (if needed), and the costs for the cable.

The costs of the substation depend on the voltage level of the grid,  $U_{grid}$  and the required installed power of the ORC unit. The costs for the substation are expressed in [€] and are defined according to Equations (6.81) – (6.84).

$$if \ U_{grid} \leq 0.4 \text{ kV} \left\{ \begin{array}{ll} ST_{cost} = 1,000 & for \ P_{ins} < 25 \text{ kW} \\ ST_{cost} = 2,000 & for \ P_{ins} < 50 \text{ kW} \\ ST_{cost} = 3,000 & for \ P_{ins} < 75 \text{ kW} \\ ST_{cost} = 4,000 & for \ P_{ins} < 100 \text{ kW} \\ ST_{cost} = 6,000 & for \ P_{ins} < 300 \text{ kW} \\ ST_{cost} = 8,000 & for \ P_{ins} < 500 \text{ kW} \end{array} \right. \quad (6.81)$$

$$if \ U_{grid} \leq 10 \text{ kV} \ \{ \ ST_{cost} = 150,000 \ for \ P_{ins} < 16,000 \text{ kW} \quad (6.82)$$

$$if \ U_{grid} \leq 20 \text{ kV} \left\{ \begin{array}{ll} ST_{cost} = 15,000 & for \ P_{ins} < 250 \text{ kW} \\ ST_{cost} = 50,000 & for \ P_{ins} < 1,000 \text{ kW} \\ ST_{cost} = 70,000 & for \ P_{ins} < 2,500 \text{ kW} \\ ST_{cost} = 150,000 & for \ P_{ins} < 16,000 \text{ kW} \end{array} \right. \quad (6.83)$$

$$if \ U_{grid} \leq 36 \text{ kV} \left\{ \begin{array}{ll} ST_{cost} = 600,000 & for \ P_{ins} < 4,000 \text{ kW} \\ ST_{cost} = 1,500,000 & for \ P_{ins} < 8,000 \text{ kW} \\ ST_{cost} = 2,500,000 & for \ P_{ins} < 16,000 \text{ kW} \end{array} \right. \quad (6.84)$$

Cable costs if not provided by the user, are defined and calculated depending also on the voltage level of the grid,  $U_{grid}$ . The costs for cables are defined according to Equation (6.85):

$$Cable_{cost} = \begin{cases} 20,000 \cdot Cable_l & \text{if } U_{grid} \leq 0.4 \text{ kV} \\ 40,000 \cdot Cable_l & \text{if } U_{grid} \leq 10 \text{ kV} \\ 50,000 \cdot Cable_l & \text{if } U_{grid} \leq 20 \text{ kV} \\ 60,000 \cdot Cable_l & \text{if } U_{grid} \leq 36 \text{ kV} \end{cases} \quad (6.85)$$

Total grid connections costs are calculated as the sum of substation costs and cable costs. However, when the grid construction actions take place, it is of significant important where the works are done. In other words, the costs of constructions are also influenced by the area and the terrain. Therefore, additional multipliers are anticipated and the approach from the GETEM model [174] was taken. By default, the area is set to urban and the terrain to flat. Hence, the total grid connections costs are calculated according to Equation (6.86):

$$C_{TOTAL}^{gridconnection} = (ST_{cost} + Cable_{cost}) \cdot m_{area} \cdot m_{terrain}, \quad (6.86)$$

where  $m_{area}$  and  $m_{terrain}$  are multipliers for area type and terrain type, respectively. Different values of those multipliers are shown in Table 6.4.

Table 6.4. Grid connection costs multipliers for area and terrain type of the project

Area type	$m_{area}$	Terrain type	$m_{terrain}$
urban	1.5	flat	1
suburban	1.2	hilly	1.2
rural	1	mountainous	1.5

#### 6.4.1.7. Heating network connection costs

When heat is produced the heating network usually needs to be built and the geothermal power plant is connected to the heating network. The functional module that calculates default costs of network construction is modelled according to [318]. Namely, the main cost is the distribution capital cost [318],  $C_d$ , which represents annual repayments of investment capital for the construction of the heating network. Thus, the distribution capital cost depends primarily on the network construction cost, which in turn is influenced by the linear heat density ( $Q_S/L$ ) of the heat demand end user. According to [318] the distribution capital cost,  $C_d$ , calculated in [€/GJ], can be estimated as shown in Equation (6.87):

$$C_d = \frac{a \cdot I_{HN}}{Q_S} = \frac{a \cdot (C_1 + C_2 \cdot d_a)}{\left(\frac{Q_S}{L}\right)}, \quad (6.87)$$

where  $a$  is the annuity, from the chosen interest rate and the investment lifetime,  $I$  the total network investment cost (€),  $Q_S$  the annual heat sold (GJ/a),  $C_1$  the construction cost constant [€/m],  $C_2$  the construction cost coefficient [€/m<sup>2</sup>],  $d_a$  the average pipe diameter [m],  $L$  the

total trench length [m] and  $\frac{Q_s}{L}$  the linear heat density [GJ/m,a]. The annuity is calculated according to Equation (6.88):

$$a = \frac{r}{(1 - (1 + r)^{-T})}. \quad (6.88)$$

The values for the cost constant,  $C_1$ , and the cost coefficient,  $C_2$ , are estimated based on calculated values in [318], and are defined for three different area characteristics: a) urban areas, b) suburban areas, and c) rural areas. The values for  $C_1$  and  $C_2$  are given in Table 6.5.

Table 6.5. Cost constants and cost coefficients for three main types of project area

Area	$C_1$ [€/m]	$C_2$ [€/m <sup>2</sup> ]
urban	286	2,022
suburban	151	1,378
rural	214	1,725

Average pipe diameter, in [m], is estimated by the following model function shown in Equation (6.90) [318]:

$$d_a = 0.0486 \cdot \ln\left(\frac{Q_s}{L}\right) + 0.0007. \quad (6.90)$$

Now the distribution capital cost is calculated according to Equation (6.84). After all these parameters have been calculated, the investment in heating network,  $I_{HN}$ , can be calculated from Equation (6.91) as:

$$I_{HN} = \frac{C_d \cdot Q_s}{a}. \quad (6.91)$$

#### 6.4.2. Operating and maintenance costs (O&M)

Operating and maintenance costs are defined on an annual basis and include operating labour costs, well field maintenance costs and power plant maintenance costs. Production and/or injection replacement costs are included in capital (investment) costs with specified replacement frequency, which is by default set at each 6 years, but could be revised by the user. O&M costs are for now user inputted parameters and no default correlations are included.

O&M costs are calculated based the approach used for default calculations in GETEM model [174]. The default O&M cost correlations are modelled for binary conversion systems, which is suitable for the evaluation model developed in this thesis.

#### 6.4.2.1. Annual labour costs

For annual labour costs, following staffing requirements are included in calculations:

- Operators;
- Maintenance: mechanic, electrician, general maintenance; and
- Office: facility manager/plant engineer, operations manager, administrative workers.

Firstly, the number of abovementioned staff needs to be calculated.

In following equations important and used parameters are:

- $P_{ins}$  – installed capacity of the power plants, in [MW], and
- $N_{units}$  – number of production units (by default this is equal 1).

Number of operators is calculated according to Equation (6.92):

$$N_{operators} = (0.25 \cdot P_{ins}^{0.525} + 0.1 \cdot (N_{units} - 1)^{0.625}). \quad (6.92)$$

Number of mechanics is calculated according to Equation (6.93):

$$N_{mechanics} = (0.15 \cdot P_{ins}^{0.65} + 0.05 \cdot (N_{units} - 1)^{0.625}). \quad (6.93)$$

Number of electricians is calculated according to Equation (6.94):

$$N_{electricians} = (0.15 \cdot P_{ins}^{0.65} + 0.05 \cdot (N_{units} - 1)^{0.625}). \quad (6.94)$$

Number of general maintenances is calculated according to Equation (6.95):

$$N_{general\_maintenance} = (0.15 \cdot P_{ins}^{0.65} + 0.05 \cdot (N_{units} - 1)^{0.625}). \quad (6.95)$$

Number of facility managers is calculated according to Equation (6.96):

$$N_{facility\_managers} = 0.075 \cdot P_{ins}^{0.65}. \quad (6.96)$$

Number of operations managers is calculated according to Equation (6.97):

$$N_{operations\_managers} = 0.075 \cdot P_{ins}^{0.65}. \quad (6.97)$$

Number of administrative workers is calculated according to Equation (6.98):

$$N_{administrative\_workers} = 0.075 \cdot P_{ins}^{0.65}. \quad (6.98)$$

Additionally, an internal database on salaries ( $salary_{type\_of\_staff}$ ) in [€/h] and working hours ( $wh_{type\_of\_staff}$ ) in [h/year] for each type of the staffing and each EU28 country was created

using the data from [319]. Based on this the costs for each staffing type are calculated according to Equation (6.99):

$$O\&M_{type\_of\_stuff} = wh_{type\_of\_staff} \cdot N_{type\_of\_staff} \cdot 1.8 \cdot salary_{type\_of\_staff} \cdot \quad (6.99)$$

Total annual labour costs are calculated as sum of all costs for each type of the stuff.

#### 6.4.2.2. Annual wellfield maintenance costs

Annual well field maintenance costs are calculated as a fraction of the capital costs for the wellfield costs according to the Equation (6.100). The default fraction  $f_{well\_field}$  is 1.2, but this can be modified by the user.

$$O\&M_{annual\_well\_field} = C_{well\_field} \cdot f_{well\_field} \quad (6.100)$$

#### 6.4.2.3. Annual power plant maintenance costs

Annual power plant maintenance costs are calculated as a fraction of the capital costs for the power plant costs according to the Equation (6.101). The default fraction  $f_{power\_plant}$  is 1.5, but this can be modified by the user.

$$O\&M_{annual\_power\_plant} = C_{power\_plant} \cdot f_{power\_plant} \quad (6.101)$$

Capital costs for power plant,  $C_{power\_plant}$  include all components costs described in Section 6.4.1.5.

### 6.4.3. Incentives

As mentioned before, EGS projects are very capital-intensive projects with high up-front costs and high risk at the beginning of the project development. Therefore, different types of incentives could help to increase the market penetration of such projects. To be able to investigate how different incentives impact overall project feasibility, various cash incentives are modelled and included in the financial analysis in the developed evaluation model.

There are three different cash related incentive approaches in the evaluation model:

- Production-based incentive (PBI);
- Capacity-based incentive (CBI); and
- Investment-based incentive (IBI).

When the production-based incentive is modelled, the cash payments to the project are calculated based on the specific production incentive value in [€/kWh] and annual energy production. The duration of the PBI has limited duration defined as term in [years].

A capacity-based incentive is a payment to the project in the first year of the project cash flow. The CBI is expressed as a function of the EGS facility rated capacity in [kW].

The investment-based incentive is calculated as the percentage of the total installed costs, in [€] and the IBI cash payment to the project is foreseen in the first year of the project cash flow.

#### 6.4.4. Calculation of levelized cost of energy

This functional module calculates one of the main economic metrics Levelized Cost of energy (LCOe) based on which the projects are compared. Depending on the production mode, i.e., the end-users, this LCOe can be levelized cost of electricity (LCOE) when electricity is produced (Equation (6.102)) and levelized cost of heat (LCOH) when the heat is produced (Equation (6.103)). In case of CHP production mode, both LCOE and LCOH are calculated (Equation (6.104) and Equation (6.105)):

$$LCOE = \frac{\sum_{t=1}^T \frac{I_t - S_t}{(1+r)^t} + \sum_{t=1}^T \frac{OM_t \cdot (1-TR)}{(1+r)^t} - \sum_{t=1}^{TD} \frac{DEP_t \cdot TR}{(1+r)^t} - \frac{RV}{(1+r)^T}}{\sum_{t=1}^T \frac{EE_t}{(1+r)^t}} \quad (6.102)$$

$$LCOH = \frac{\sum_{t=1}^T \frac{I_t - S_t}{(1+r)^t} + \sum_{t=1}^T \frac{OM_t \cdot (1-TR)}{(1+r)^t} - \sum_{t=1}^{TD} \frac{DEP_t \cdot TR}{(1+r)^t} - \frac{RV}{(1+r)^T}}{\sum_{t=1}^T \frac{EH_t}{(1+r)^t}} \quad (6.103)$$

$$LCOE(chp) = \frac{\sum_{t=1}^T \frac{I_t - S_t}{(1+r)^t} + \sum_{t=1}^T \frac{OM_t \cdot (1-TR)}{(1+r)^t} - \sum_{t=1}^{TS} \frac{RHS_t \cdot (1-TR)}{(1+r)^t} - \sum_{t=TS+1}^T \frac{RHM_t \cdot (1-TR)}{(1+r)^t} - \sum_{t=1}^{TD} \frac{DEP_t \cdot TR}{(1+r)^t} - \frac{RV}{(1+r)^T}}{\sum_{t=1}^T \frac{EE_t}{(1+r)^t}} \quad (6.104)$$

$$LCOH(chp) = \frac{\sum_{t=1}^T \frac{I_t - S_t}{(1+r)^t} + \sum_{t=1}^T \frac{OM_t \cdot (1-TR)}{(1+r)^t} - \sum_{t=1}^{TS} \frac{RES_t \cdot (1-TR)}{(1+r)^t} - \sum_{t=TS+1}^T \frac{REM_t \cdot (1-TR)}{(1+r)^t} - \sum_{t=1}^{TD} \frac{DEP_t \cdot TR}{(1+r)^t} - \frac{RV}{(1+r)^T}}{\sum_{t=1}^T \frac{EH_t}{(1+r)^t}} \quad (6.105)$$

where:

- $t$  represents year in a period of a lifetime  $[1, T]$ ,
- $I_t$  is total investment costs in year  $t$ , in [€],
- $OM_t$  is maintenance and operation expenditures in year  $t$ , in [€],
- $S_t$  represents incentives or subsidies in [€] in year  $t$ ,

- $TR$  is effective corporate tax rate, in [%],
- $DEP_t$  is depreciation in year  $t$ , in [€],
- $RV$  is residual value in [€] in year  $T$ ,
- $EE_t$  is generated electricity in year  $t$ , in [MWh or kWh],
- $EH_t$  is generated heat in year  $t$ , in [MWh or kWh],
- $r$  represents discount rate in [%],
- $RES_t$  represents revenues from the electricity sales in year  $t$ , subsidized price (production-based incentives), in [€],
- $REM_t$  revenues from the electricity sales in year  $t$ , market price, in [€],
- $RHS_t$  represents revenues from the heat sales in year  $t$ , subsidized price (production-based incentives, in [€],
- $TS$  represents duration of subsidized price of electricity or heat, in [years], and
- $RHM_t$  revenues from the heat sales in year  $t$ , market price, in [€].

Total investment costs in year  $t$  in Equations (6.102) – (6.-105) are calculated as the sum of capital costs described in Section 6.4.1 according to Equation (6.106):

$$I_t = I_t^{permitting} + I_t^{exploration} + I_t^{drilling} + I_t^{surf\_equip} + I_t^{gather\_sys} + I_t^{other\_inv} , \quad (6.106)$$

where:

- $I_t^{permitting}$  represents permitting costs in year  $t$  [€],
- $I_t^{exploration}$  represents exploration costs in year  $t$  [€],
- $I_t^{drilling}$  represents drilling costs in year  $t$  [€],
- $I_t^{surf\_equip}$  surface equipment investment costs in year  $t$ , these include grid connection costs [€],
- $I_t^{gather\_sys}$  represents gathering system investment costs in year  $t$ , these include also production and injection pumps [€], and
- $I_t^{other\_inv}$  represents – other investment costs not covered by all the mentioned costs [€].

Total O&M costs are calculated as the sum of all operating costs described in Section 6.4.2. according to Equation (6.107):

$$OM_t = OM_t^{labour} + OM_t^{well\_field\_main} + OM_t^{power\_plant\_main} , \quad (6.107)$$

where:

- $OM_t^{labour}$  represents personnel costs in year  $t$  [€],
- $OM_t^{well\_field\_main}$  represents well field maintenance costs in year  $t$ , including submersible pumps replacement costs etc. [€], and
- $OM_t^{power\_plant\_main}$  represents power plant maintenance costs in year  $t$  [€].

In the equations for LCOE and LCOH for the CHP production mode the revenues from heat and electricity, respectively, are calculated according to following equations:

$$RES_t = EE_{net,t} \cdot SPE_t \quad (6.108)$$

$$REM_t = EE_{net,t} \cdot MPE_t \quad (6.109)$$

$$RHS_t = EH_{net,t} \cdot SPH_t \quad (6.110)$$

$$RHM_t = EH_{net,t} \cdot MPH_t, \quad (6.111)$$

where:

- $EE_{net,t}$  represents net production of electricity in [MWh] in year  $t$ ,
- $SPE_t$  represents subsidized price of electricity in [€/MWh] in year  $t$ ,
- $MPE_t$  represents market price of electricity in [€/MWh] in year  $t$ ,
- $EH_{net,t}$  represents net production of heat in [MWh] in year  $t$ ,
- $SPH_t$  represents subsidized price of heat in [€/MWh] in year  $t$ , and
- $MPH_t$  represents market price of heat in [€/MWh] in year  $t$ .

#### 6.4.5. Financial profitability

Once the investment costs, operating and maintenance cost and revenues, and sources of financing are determined and calculated, the assessment of the project profitability can be done, which is measured by two key indicators:

- Net present value– NPV(C) - and internal rate of return– IRR(C) - on investment; and
- Net present value– NPV (K) - and internal rate of return - IRR (K) - on capital.

##### 6.4.5.1. NPV and IRR on investment

The net present value of investment (NPV(C)) and the internal rate of return of the investment (IRR(C)) compare investment costs to net revenues and measure the extent to which the project net revenues are able to repay the investment, regardless of the sources or methods of financing.



The NPV(C) is defined as the sum that results when the expected investment and operating costs of the project (discounted) are deducted from the discounted value of the expected revenues:

$$NPV(C) = \sum_{t=0}^T a_t \cdot S_t = \frac{S_0}{(1+i)^0} + \frac{S_1}{(1+i)^1} + \dots + \frac{S_T}{(1+i)^T} , \quad (6.112)$$

where the  $S_t$  is the balance of cash flow (inflows minus outflows) at the time  $t$ ,  $a_t$  is the financial discount factor chosen for discount at the time  $t$ , and  $i$  is the nominal discount factor.

The IRR(C) on investment is defined as the discount rate that produces a zero NPV, i.e. it is calculated with the following equation:

$$0 = \sum_{t=0}^T \frac{S_t}{(1+IRR)^t} . \quad (6.113)$$

The NPV(C) is expressed in [€], and the IRR(C) is expressed in [%]. When the IRR(C) is lower than the applied discount rate or the NPV(C) is negative, the generated revenues will not cover the costs and the project needs assistance (mainly EU).

As mentioned, net present value and return on investment is calculated considering only investment costs and operating costs as outflows, and revenues and residual value as inflows. Thus, the costs of financing are not included in these calculations.

#### 6.4.5.2. NPV and IRR on capital

The objective of the return on capital calculation is to examine the project performance from the perspective of the supporting public, and, if applicable, private entities.

The return on capital is calculated considering as cash outflows: the operating costs, the national (public and private) capital contributions to the project, the other financial resources from loans at the time in which they are reimbursed, and the related interest on loans. The cash inflows are the operating revenues only (if any) and the residual value.

The financial net present value of capital, NPV(K), in this case, is the sum of the net discounted cash flows that accrue to the national beneficiaries (public and private combined) due to the implementation of the project. The corresponding financial rate of return on capital, IRR(K), of these flows determines the return in percentage points.

For public infrastructure, a negative NPV(K) after EU assistance does not mean that the project is not desirable from the operator's or the public's perspective and should be cancelled. It just means that it does not provide an adequate financial return on employed national capital.

#### 6.4.6. Financial sustainability

The project is financially sustainable when the risk of running out of cash in the future, both during the investment and the operational stages, is expected to be nil. Project promoters should elaborate how the sources of available financing (both internal and external) will consistently match disbursements year-by-year.

The difference between cash inflows and outflows will show the deficit or surplus that will be accumulated each year. Sustainability occurs if the cumulated generated cash flow is positive for all the years considered. The cash inflows include:

- Sources of financing;
- Operating revenues from the provision of goods; and
- Subsidies and other financial gains.

The cash outflows include:

- Investment costs;
- Replacement costs;
- O&M costs;
- Reimbursement of loans and interest payments; and
- Taxes on income and other direct taxes.

### 6.5. INTERNAL DATABASES

The developed evaluation model uses internal data from databases for country specific data (EU28 countries) related to:

- Outside (ambient) temperature;
- Electricity and heat market prices;
- Emission factors; and
- O&M salaries.

The outside temperature database is used for electricity production calculations when the air-cool condenser type in the ORC unit is used. The average monthly temperatures are defined for each EU28 country for the whole calendar year.

The electricity and heat market prices are collected from official spot market websites for each EU28 country for the years from 2015 to 2022. These historic values are then used in the default prices forecasting function which, based on this data predicts the market prices for electricity and/or heat till the end of the project’s lifetime. Forecasting is about predicting the future as accurately as possible, given all of the information available, including historical data and knowledge of any future events that might impact the forecasts. The appropriate forecasting methods depend largely on what data are available. In other words, quantitative forecasting can be applied if some conditions are satisfied. To conduct successful quantitative forecasting the numerical information about the past must be available, and it is reasonable to assume that some aspects of the past patterns will continue and repeat into the future. Most quantitative prediction problems use time series data, that is collected at regular intervals over time. From this exact reason the time series model is used in the evaluation model for market prices forecasting. Exponential smoothing and ARIMA models are the two most widely used approaches to time series forecasting and provide complementary approaches to the problem. While exponential smoothing models are based on a description of the trend and seasonality in the data, ARIMA models aim to describe the autocorrelations in the data.

ARIMA is an acronym that stands for *AutoRegressive Integrated Moving Average*. It is a generalization of the simpler *AutoRegressive Moving Average* and adds the notion of integration. AutoRegressive (AR) Models operate under the premise that past values have an effect on current values. The order of AR model corresponds to the number of days incorporated in the formula. Moving Average Model (MA) assumes the value of the dependent variable on the current days depend on the previous days error terms. If differencing is combined with autoregression and a moving average model, a non-seasonal ARIMA model is obtained. The full model can be written as:

$$y'_t = c + \phi_1 y'_{t-1} + \dots + \phi_p y'_{t-p} + \theta_1 \varepsilon_{t-1} + \dots + \theta_q \varepsilon_{t-q} + \varepsilon_t , \quad (6.114)$$

where  $y'_t$  is the differenced series (it may have been differenced more than once), the ‘predictors’ on the right-hand side include both lagged values of  $y_t$  and lagged errors, and  $\varepsilon_t$  white noise.

Usual notation of such model is ARIMA(p,d,q) model:

- $p$  = order of autoregressive part (AR order),
- $d$  = degree of first differencing involved, and
- $q$  = order of the moving average part (MA order).

Based on the above description and literature review, the ARIMA model is chosen and modelled for the electricity and/or heating power market price forecasting. The forecasted values can be either monthly or yearly values, depending on the desired time resolution. Moreover, three different scenarios of forecasted prices are included, i.e., low prices, average prices or high prices, meaning the user can estimate the obtained revenue for all three different possible scenarios. The low prices are estimated to be 20% lower than the predicted average prices, and high prices are estimated to be 20% higher than the predicted average prices.

Emission factors are used to calculate the avoided CO<sub>2</sub> emissions as described in Chapter 5, Section 5.3.1.25. The emission factors are collected for all EU28 countries.

O&M salaries are used as described in Section 6.4.2.1.

## 6.6. DECISION-SUPPORT TOOL – A STANDALONE APPLICATION

To make the developed evaluation model, described in Sections 6.1. - 6.4., a functional unit usable by all types of users (i.e. experienced and less experienced) and applicable for both analytic purposes and educational purpose, a decision-support tool in a form of standalone application was developed. The standalone application developed in MATLAB environment, provides user friendly graphical user interface (GUI) and can be installed on any operating system. The decision-support tool can be used to estimate different important economic indices for a defined geothermal (EGS) scenario, provides MCDM analysis and facilitates the decision-making process.

In this Section, the application layout is presented and described.

### 6.6.1. GUI – main window

The main window of user-friendly GUI is shown in Figure 6.19. It contains main tabs which are used to either open the interfaces of sub-applications (which are basically different functional modules of the evaluation model), to analyse obtained results or to conduct the MCDM analysis. The main tabs and their purpose are shortly described in Table 6.6.

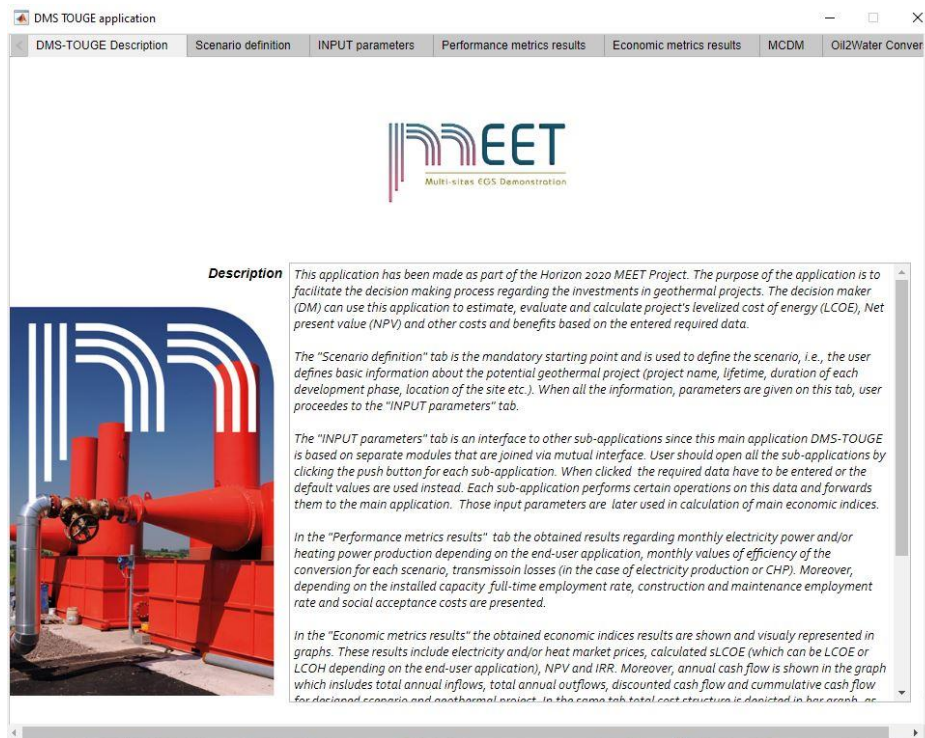

Figure 6.19. Decision-support tool - main window of GUI

Table 6.6. Decision-support tool main window tabs and their purpose

Tab	Description
DMS-TOUGE Description	General description of the tool.
Scenario definition	Basic information on project and scenario.
INPUT parameters	Interface to the sub-applications.
Performance metrics results	Visualisation of power plant performance
Economic metrics results	Economic results – LCOE, NPV, IRR, etc.
MCDM	Multi-criteria decision-making table for MCDM analysis.
Oil2Water Conversion	Additional feature, the Excel-based methodology and tool for economic evaluation of end-of-field life conversion presented in [130].

### 6.6.2. Scenario definition

Basic information about the scenario to be evaluated is defined in the *Scenario definition* tab (Figure 6.20). This is the mandatory starting point where the user defines basic information about the desired geothermal project. When all parameters on afore-described tab are inserted, the user proceeds to the *INPUT parameters* tab.

The screenshot shows the 'Scenario definition' tab in the DMS-TOUGE application. The main form area is titled 'Project description' and contains the following fields and controls:

- Name of the project:
- Description of the project:
- Lifetime of the geothermal project:  years
- Duration of phases [years]:
 

Permitting	<input type="text" value="2"/>
Exploration	<input type="text" value="2"/>
Drilling	<input type="text" value="2"/>
Construction of power plant	<input type="text" value="2"/>
Operation	<input type="text" value="0"/>
- Start of the project:
- Country:
- Project site area:
- Project site terrain:
- Price scenario: low  average  high
- Time resolution: yearly  monthly
- Social attitude towards the project:

Figure 6.20. Scenario definition tab

### 6.6.3. Gathering all relevant input data via sub-applications

*INPUT parameters* tab (Figure 6.21) is basically an interface to all the sub-applications where specific input parameters from different groups of parameters are entered. Not only do the sub-applications serve as input parameters gathering tool, but also as pre-calculating mechanism for each group of the input parameters specific to each sub-application.

The user should follow the order when inputting the parameters in each sub-application. The sub-applications are opened by clicking the button of each one. However, it is paramount to follow the right order of input data entry. Therefore, next sub-application is enabled to be opened just after the sub-application before it has been opened and filled with required data. When all the sub-applications are opened, and data is inputted, and corresponding pre-calculations are conducted the user pushes **Prepare data and forecast** button (red rectangle). Afterwards, the **Financial Analysis** button (blue rectangle) can be pushed to obtain the economic metrics results.

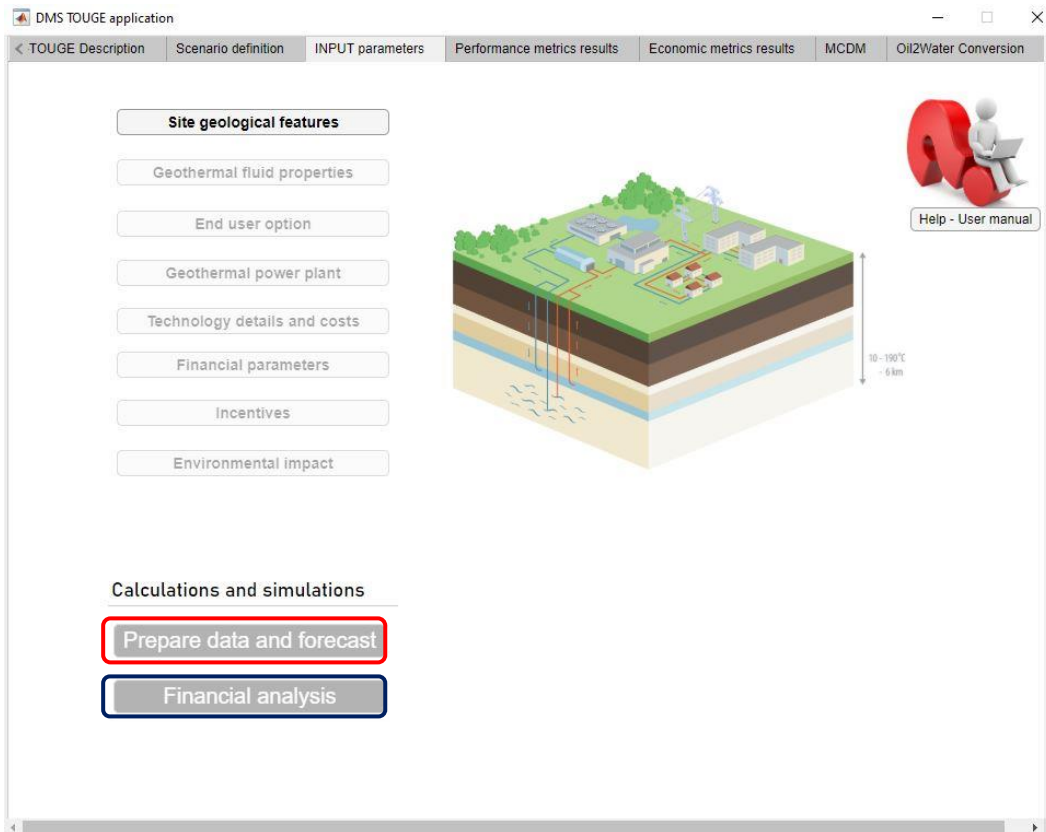
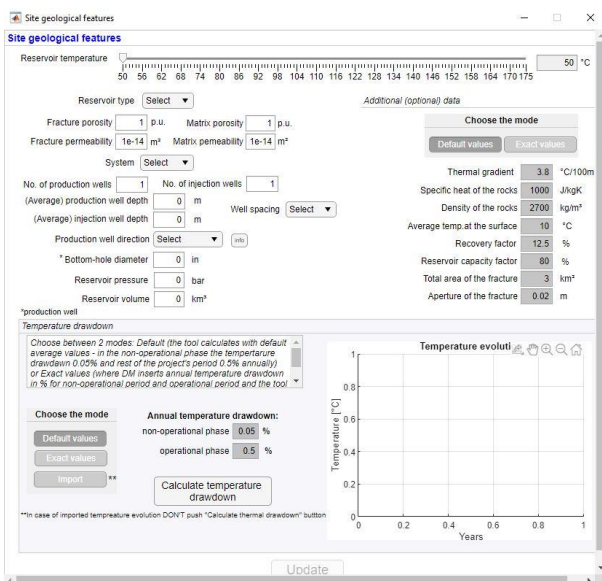
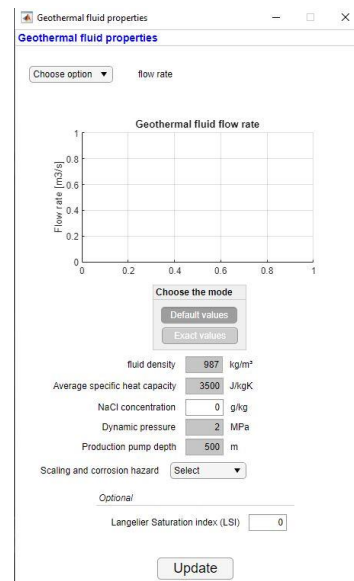

Figure 6.21. INPUT parameters tab

The interface windows for each sub-application are shown in Figure 6.22. The sub-applications are: (a) site geological features, (b) geological fluid properties, (c) end-user option characteristics, (d) geothermal power plant, (e) technology details and costs, (f) financial parameters, (g) incentives, and (h) environmental impact.



(a) Site geological features



(b) Geological fluid properties

**End user option**

**Choose the end user application** Distance to: nearest water  km \* fill in only in case of water cooling condenser type

District heating  
 Agriculture  
 Greenhouse  
 Biotechnology  
 Industry

Only electricity generation  
 CHP

Application

**Heating network characteristics**

Supply:  °C Insulation  Pipe diameter (DN):  mm

Return:  °C Installation  Primary pipes length  m

Secondary pipes length  m

Tertiary pipes length  m

Time resolution (mass flow): yearly  monthly

Mass flow:  kg/s

Fluid pressure:  MPa

Specific heat capacity:  J/kgK

**Mass flow**

**Heat demand**

**Power grid characteristics**

Voltage level:

Interconnection costs:

(c) End-user option characteristics

**Geothermal power plant**

Depending on the site features and consumption needs, different power plants can be installed. Two main groups are CHP unit (where no combined power and heat production is possible) and CHP unit (where combined power and heat production are possible). This application action is retrieved from the End-user action module.

**Surface facility**

Wellhead temperature  °C Delta T  °C

Injection temperature  °C

Dead state temperature  °C

Power plant availability  %

Month of maintenance

Mean plant capacity factor  %

Safe margin  °C

Informative inlet ORC heat exchanger outlet temp  °C

Informative inlet ORC heat exchanger outlet temp  °C

**CHP unit**

Series cycle  
 Parallel cycle

**Efficiency**

Turbine  %

Generator  %

HEX  %

Submersible pumps  %

**Permissible load**

Working fluid cooling  kW

Working fluid pumping  kW

Submersible power  kW

Injector pump power  kW

TOTAL  kW

**Injection equipment pressures**

Pump intake pressure  bar

Wellhead injection pressure  bar

Max allowable wellhead pressure  bar

Injection pressure qualitative

**Series cycle**

Heat transfer coefficient  W/m<sup>2</sup>K

HEX area  m<sup>2</sup>

HEX heat transfer efficiency  %

HEX max power  kW

Chosen Psk  kW

Mean CHP efficiency  %

**Plot resolution**

yearly  monthly

(d) Geothermal power plant

**Technology details**

**Technology details and costs**

**Permitting costs**

Number of sites

Pre-drilling activities  €/per site

For drilling-exploration and early drilling  €/per site

Utilization permit  €

TOTAL  €

**Exploration costs**

Number of sites

Pre-Drilling costs  €/per site

Drilling costs  €/per site

Leasing cost  €

Additional costs  €

TOTAL  €

**Drilling costs**

Prod. well  Inje. well

Production well  €/per well

Injection well  €/per well

Stimulation costs  €/per well

Additional costs  €

TOTAL  €

**Equipment investment costs**

**Plant equipment**

CEPCI index

ORC

Turbine  €

Generator  €

Heat exchanger  €

Condenser  €

Centrifugal pump  €

Auxiliary HEX  €

Additional pipes  €/m

Heating plant

Heating network  €

Heat exchanger  €

Auxiliary HEX  €

Additional pipes  €/m

TOTAL  €

**Grid connection**

Grid voltage  kV

ORC voltage  kV

Cable material

Cable cross section  mm<sup>2</sup>

Cables cost  €/km

Cables length  km

Substation costs  €

Calculate costs

TOTAL  €

**Gathering system**

Production pump

Replacement each  y

Number of production pumps

Injection pump

Replacement each  y

Number of injection pumps

Distance between wells  m

Pipes length  m

TOTAL  €

Other costs

Total equipment investment costs  €

Total capital costs  M€

(e) Technology details and costs

**Financial parameters**

**Financial parameters**

**Analysis parameters**

Choose the mode

Inflation rate  %/year

Discount rate  %/year

Nominal discount rate  %/year

Effective tax rate  %/year

Insurances  % of installed

**Property tax**

Assessed percentage  % of installed costs

Assessed value  €

Property tax rate  %/year

**Sources of financing**

Private capital

Community assistance

National public contribution

Other resources

**Project term debt**

debt percentage  %

interest rate  % annual

period (years)  years

beginning date

**Depreciation schedule**

Year	Rate
1	20.0000 %
2	32.0000 %
3	19.2500 %
4	11.8200 %
5	11.5200 %
6	5.7800 %

**Selling prices**

In case the end product (electricity/heat) is sold on the electricity market, meaning no incentives are involved then please choose between 2 modes: "market" mode - anticipate and forecast electricity or heat prices and

Heat selling prices

Electricity selling prices

Default forecast

Default forecast

(f) Financial parameters



(g) Incentives

(h) Environmental impact

Figure 6.22. Interfaces of the sub-applications used to collect all important input data, to execute pre-calculations and to provide output parameters used later in financial analysis and MCDM analysis

#### 6.6.4. Preparing data and executing financial analysis of the project

Once all the sub-applications have been opened and required data inputted, the user should push the **Prepare data and forecast** button (Figure 6.21). When pushed, the tool calculates following:

- Revenues from the sold electricity and/or heating power;
- Social acceptance costs;
- Employment rate – full time and O&M jobs; and
- Global efficiency of the power plant.

It also visually represents calculated performance metrics results on the graphs in the **Performance metrics results** tab described in the Section 6.6.4.1 .

When the necessary data is prepared and calculated the **Financial analysis** button (Figure 6.21) must be pushed. This action triggers the calculation of all the economic metrics:

- Loan – the function calculates the amortization table with the inserted parameters (debt share, debt tenor, interest rate, beginning date). This is later used in the financial analysis.
- Tax – the function calculates the tax payments which are later included in cash flow and financial analysis.

- Incentives – with inserted parameters in the *Incentives* sub-application the function calculates existing incentives (production-based incentive (PBI), capacity-based incentive (CBI)).
- Systems levelized cost of energy (sLCOE) – for only heat production the levelized cost of heat (LCOH) is calculated, for only electricity production the levelized cost of electricity (LCOE) is calculated and for CHP the user can choose to consider either LCOE or LCOH.
- Net present value (NPV) – financial net present value on the investment (NPV(C)) and financial net present value on capital (NPV(K)) are calculated. To gain the contribution from the funds (e.g., EU) the NPV(C) should be negative.
- Internal rate of return (IRR) – internal rate of return on investment (IRR(C)) and internal rate of return on capital (IRR(K)) are calculated. The project that can gain the contribution from the funds should have lower IRR(C) than the discount rate used for the analysis.

The main economic metrics are shown in the **Economic metrics results** tab which is described in detail in Section 6.6.4.2.

#### 6.6.4.1. *Performance metrics results*

This tab is used to visually represent the obtained calculated results considering the performance of the modelled system and scenario. Presented graphs are as shown in Figure 6.23:

- Installed power – electrical (in case of only electricity production mode or CHP mode);
- Installed power – heating (in case of only heat production mode or CHP mode);
- Produced energy – total generated electricity for the lifetime period of the project [MWh<sub>e</sub>] in case of only electricity production and CHP;
- Produced thermal energy – total produced heating energy for the lifetime period of the project [MWh<sub>th</sub>] in case of only heat production and CHP;
- Full-time (FT) employment;
- Construction and Manufacturing (CM) employment rate;
- Social acceptance costs – calculated social acceptance costs based on the installed capacity;
- Avoided CO<sub>2</sub> emissions – calculated in the *Environment* sub-application;

- Energy production – monthly values; either only electricity or only heating power, or both in case of CHP;
- Efficiency of the conversion process – monthly values; and
- Energy loss due to the electricity transmission – monthly values.

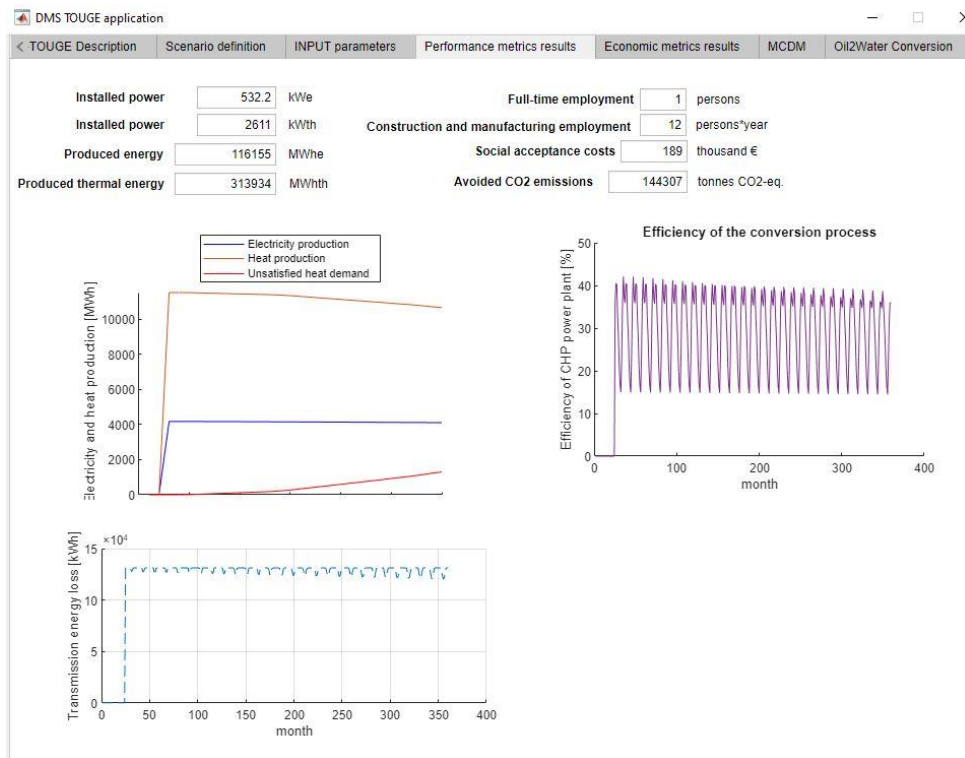

Figure 6.23. Performance metrics results (example for the CHP production mode)

#### 6.6.4.2. Economic metrics results

This tab is used to display the obtained calculated results of economic indices. Presented values and graphs as shown in Figure 6.24 are:

- Electricity prices – monthly or yearly values. In case of only electricity production and CHP;
- Heat prices – monthly or yearly values. In case of only heat production and CHP;
- Project cash flow through all development phases;
- Total structure of the costs – investment (capital costs), operation and maintenance costs (O&M) and financing cost (e.g., loan payments);
- Investment cost structure – fixed assets costs and start-up costs;
- Percentage of each investment costs – cost related to each phase of the project development;
- LCOE – levelized cost of electricity for only electricity production case and CHP if the electrify is the main product;

- LCOH – levelized cost of heat for only heat production case and CHP if the heating power is the main product;
- NPV(C) – net capital value of investment. If this is negative, the project can receive financing from the funds. The financial net present value of investment (FNPV(C)) and the financial rate of return of the investment (FRR(C)) compare investment costs to net revenues and measure the extent to which the project net revenues are able to repay the investment, regardless of the sources or methods of financing;
- IRR(C) – internal rate of return of investment. If this is lower than the used discount rate in the DCF calculations the project can receive financing from the funds;
- NPV(K) – net present value of capital. It is the sum of the net discounted cash flows that accrue to the national beneficiaries (public and private combined) due to the implementation of the project. (green underline) The corresponding financial rate of return on capital, FRR(K), of these flows determines the return in percentage points. When computing FNPV(K) and FRR(K), all sources of financing are taken into account; and
- IRR(K) – internal rate of return on capital. The return on national capital is calculated considering as outflows: the operating costs; the national (public and private) capital contributions to the project; the financial resources from loans at the time in which they are reimbursed; the related interest on loans.

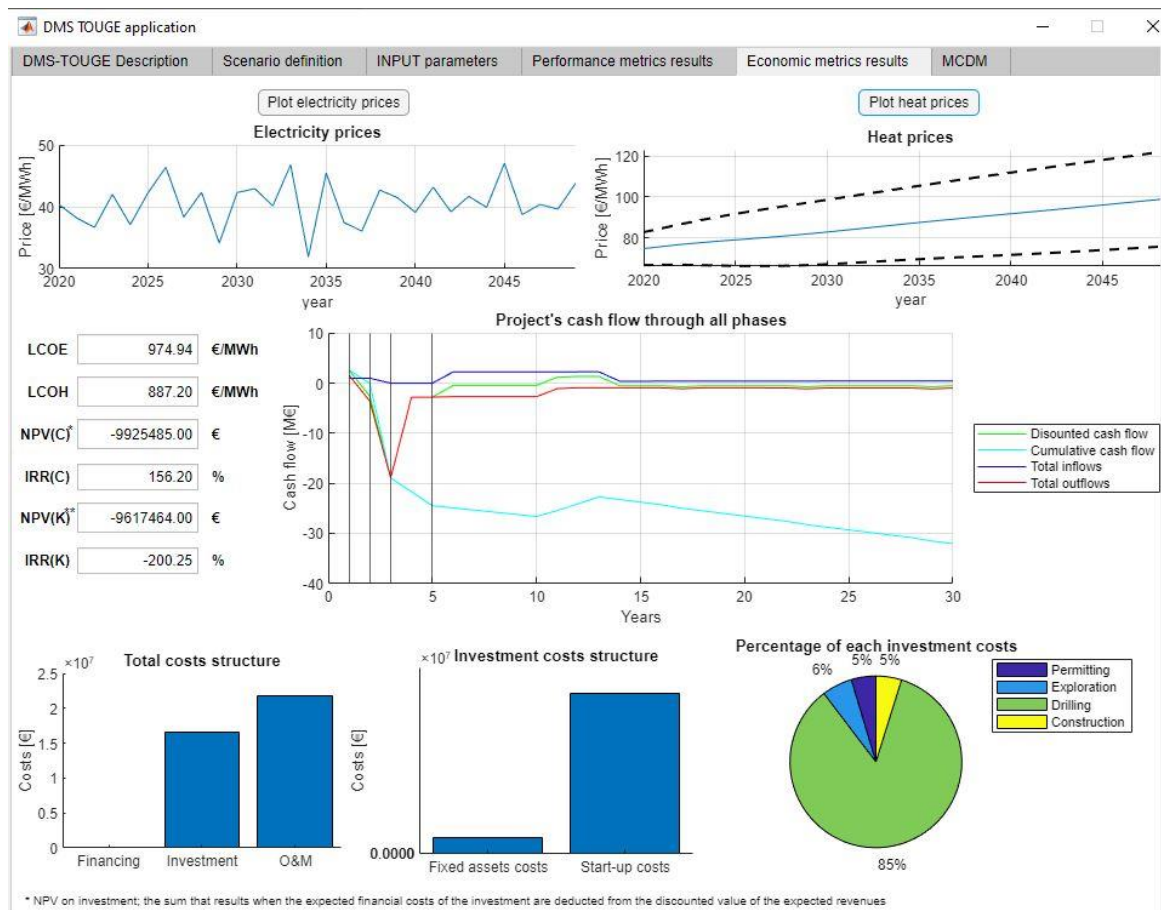

Figure 6.24. Economic metrics results (example for CHP production mode)

### 6.6.5. MCDM analysis

This tab incorporates MCDM analysis functional module developed as the MCDM matrix has been developed for the MCDM analysis which is established as described in Chapter 5 and is a subprocess in the evaluation model used for preliminary evaluation of different geothermal sites (EGS sites) and technologies for electricity and/or heat production. This MCDM functional module can be used to process 'raw' data shown in Section 6.6.4.1 and Section 6.6.4.2.

The *MCDM tab* consist of the table (Figure 6.25) in which the columns represent the options from 1 to 5, i.e., different scenarios. In other words, user can evaluate and compare up to 5 different scenarios in current version of tool. The rows represent 28 different criterions (Figure 6.25). The table with column name weight represents the weights for each criterion obtained using the AHP method. In some way the user models the final decision since its preferences are reflected in the weight definition. In other words, the weights of each criterion reflect the relative importance between criterions from the perspective of the DMT user.

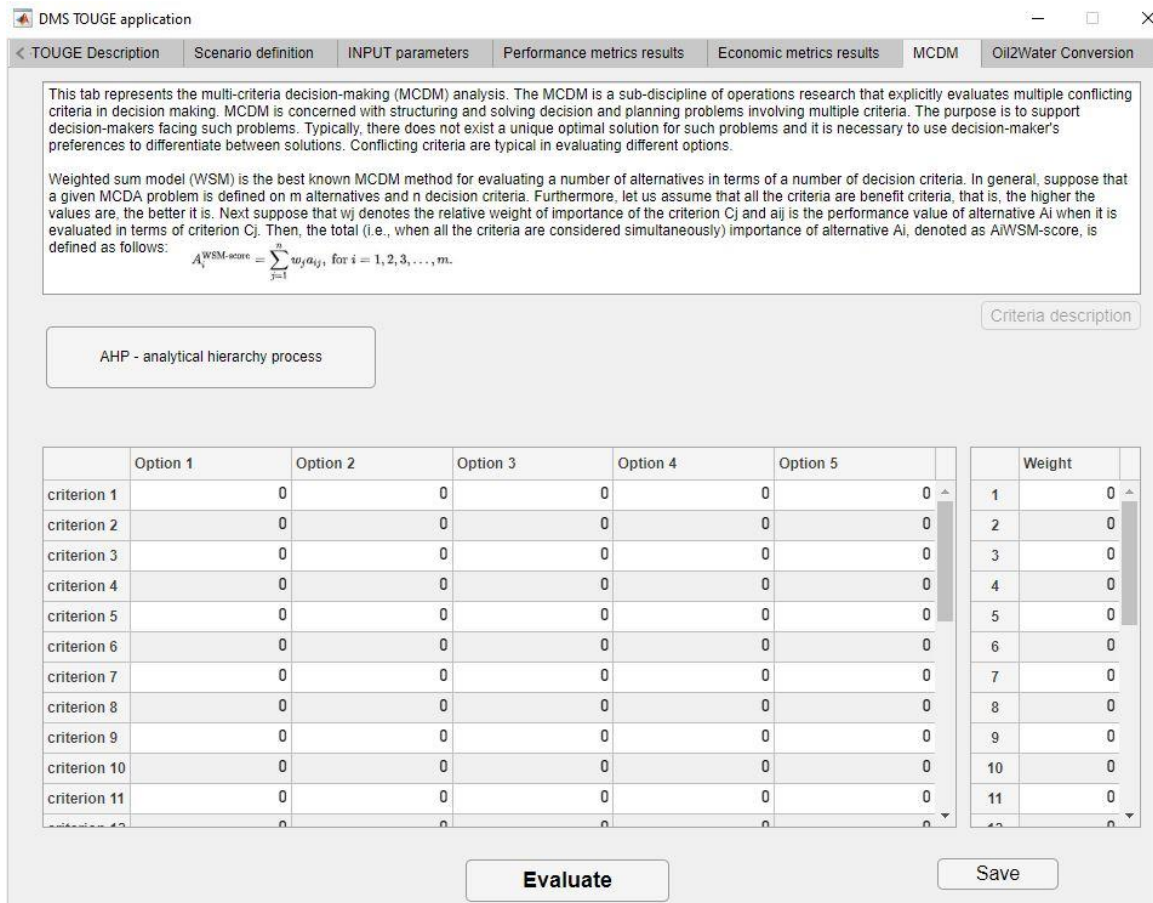

Figure 6.25. MCDM analysis tab

### 6.6.6. Oil-to-Water conversion methodology

The Excel-based methodology and the tool for economic evaluation of end-of-field life conversion is accessible on this tab as an additional feature of the evaluation model. The methodology was developed as part of the Horizon 20202 MEET project (GA No. 792037) and is thoroughly described in [130]. It enables the assessment of conversion process of mature and abandoned oil or gas fields into geothermal asset for heat and/or electricity production.

Five different scenarios are modelled:

- 1) "Do nothing scenario" - plug wells and abandoned facilities;
- 2) "Heat doublet scenario" - heat is extracted via doublet technology (production-injection wells);
- 3) "Heat DBHE scenario" - heat is extracted via deep borehole heat exchanger;
- 4) "ORC power" - heat is extracted via doublet technology and used in Organic Rankine Cycle unit to generate electricity; and
- 5) "Power and heat scenario" - asset is converted for both heat and electricity production (CHP); parallel configuration [15] of CHP plant is modelled.

The main outputs are energy production quantities, LCOE/LCOH, NPV, energy efficiency (energy output/energy input), avoided CO<sub>2</sub> emissions.

This set of outputs facilitates the decision-making process related to end-of-field life conversion.

Detailed explanations and guidelines on how to use the Excel-based methodology are listed in the Excel sheet which opens when the 'O2W conversion' button is pushed. To open and access the methodology press the push button 'O2W conversion' Figure 6.26.

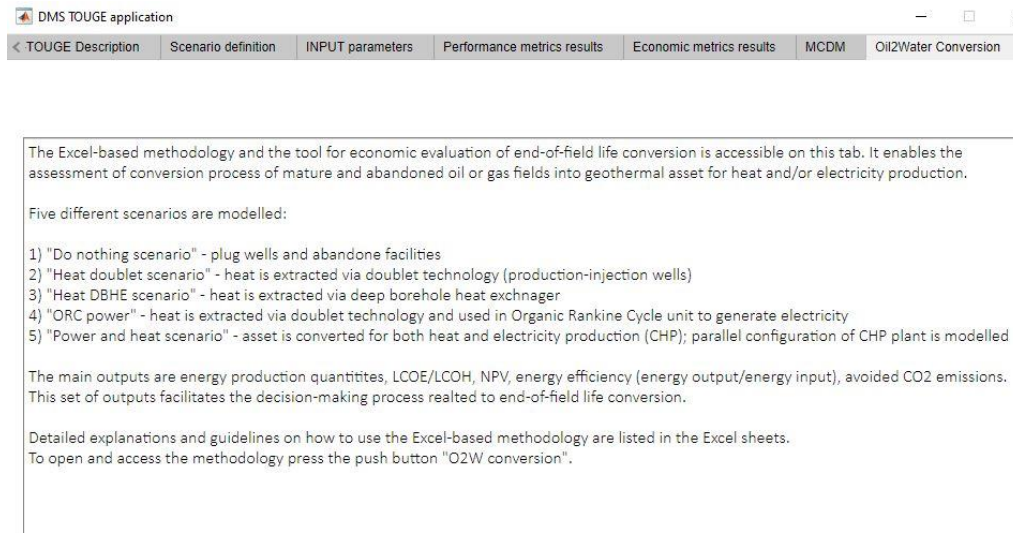

Figure 6.26. Oil-to-Water conversion methodology tab

## 6.7. TESTING OF THE EVALUATION MODEL AND DECISION-SUPPORT TOOL

The evaluation model can be used for evaluation of EGS projects and i) comparison of different geothermal energy utilization options at the same geothermal site or ii) comparison of development of EGS project at different geothermal sites. Additionally, as depicted in Figure 6.3, the evaluation model and decision-support tool offer the capability to acquire data in both raw and decision format. In essence, proficient users and experts possessing ample experience in decision-making, project development, and modelling can employ the raw data to conduct their independent scenario analyses and interpret the results in alignment with their preferences and requirements. Conversely, less experienced users are inclined to utilize the MCDM functionality of the evaluation model, which facilitates the comparison of various options without necessitating an in-depth understanding of all input and output parameters

and their interrelationships. Hence, to demonstrate the dual usability of the evaluation model can be used, Section 6.7.1 presents the results of independent scenario analysis utilizing raw data for a single geothermal site, along with comparison of different geothermal energy utilization options. In contrast, Section 6.7.2 delineates the results of MCDM analysis conducted for multiple geothermal sites, emphasizing the comparison of different EGS projects implemented on those selected sites.

Furthermore, the case studies in the next two sections are used to validate the functionalities of the evaluation model and the operability of each sub-module as part of the evaluation model. Calculations are done on a hourly basis, whereas the results of the assessment with evaluation model are presented on monthly or yearly basis. Additionally, the case studies in Section 6.7.1 and Section 6.7.2 are used for verification of the developed and modelled evaluation model.

#### 6.7.1. Comparison of different geothermal energy utilization options at the same geothermal site

The analysis was conducted for a geothermal pilot site in Variscan geology where some infrastructure is existing, and the evaluation of geothermal potential is undertaken. Based on the analysis, the possible direction of achieving optimal direction of future geothermal energy utilization on this site is evaluated.

The geothermal site is located in Havelange, Belgium. The deep borehole (5,648 m) was drilled in early 1980's as an exploration well targeting natural gas resources potentially trapped below the main Variscan external thrust (Midi-Eifel Fault). It is up to now the deepest borehole in Belgium. It also represents one of the rare cases of exploration borehole investigating the deep structure of Lower Devonian formations in the external Variscan fold-and-thrust belt. Of particular interest is the quartzite members that were cored in Havelange at a depth of ~ 4.5 km with a recorded temperature near 100°C.

The Havelange demo site is located in the EGS-target horizon in non-granitic Variscan basement in the category where the Variscan structure is preserved without later modification and has an approx. 5,000 m deep well with promising rock types and permeabilities for an enhancement in the sense of a geothermal system.

The Havelange demo-site is located in a rural environment (Figure 6.27). The energy valorisation options are therefore constrained to specific heat demands to be developed or to target electricity production.





Figure 6.27. Landscape view from the Havelange site (source: [320])

#### 6.7.1.1. Chosen site general information

General information about main characteristics of Havelange site is presented in Table 6.7. The site is in exploration site with conducted 2D seismic analysis, analogue studies, and research well preparation, and abandoned exploration well (natural gas), respectively. The reliability level for obtained economic and performance results highly depends on the certainty level of input data. Therefore, since there are no geological and geophysical well data and no reliable numerical reservoir models yet for the Havelange site, several probable scenarios for brine flow rate and wellhead temperature were considered.

Table 6.7. Main characteristics of chosen existing geothermal sites

Parameter	Havelange
Location	Havelange (Wallonia, Belgium)
Project status	Abandoned exploration well (natural gas)
Existing infrastructure	subsurface infrastructure
Reservoir rock type	meta-sedimentary rocks (Palaeozoic)
Number of wells	1 (exploration)
Depth of wells	5,648 m
Production temperature	126°C
Reinjection temperature	not applicable
Flow rate	-

The Havelange demonstration site comprises a single abandoned exploration well, which, based on its characteristics, appears to be more suitable for conversion into an injection well rather than and production well which is well established practice.

#### 6.7.1.2. Analysis methodology

The analysis conducted here encompassed three parallel analyses, namely, electricity production, district heating, and combined heat and power (CHP) options. The rationale behind examining all these end-user possibilities stemmed from the fact that there exists only one well on the field, likely intended for injection due to its substantial diameter. From the outset of drilling and exploration activities at this site, only a limited number of studies have been conducted to assess its geothermal potential, primarily yielding geological logs, cuttings, cores, and seismic data.

In this analysis, three scenarios were established for each of the three end-uses:

- A reference case;
- An optimistic case; and
- A pessimistic case.

This scenario diversification was prompted by the inherent uncertainty surrounding geothermal reserves in the reservoir, the dubious technological feasibility of geothermal exploitation, and the site's rural location. As a result, the end-uses most closely aligned with heating requirements, such as those serving the campus, military zone, activity area, industry, cinema, and restaurant, were prioritized. Additionally, the nearest electrical network is situated approximately 6.5 kilometres away (Figure 6.28).

For determining the wellhead temperature, which is equivalent to the reservoir temperature, a geothermal gradient of 0.0202°C/m in the reference case, 0.025°C/m in the optimistic case, and 0.019°C/m in the pessimistic case were considered. This gradient was coupled with a temperature decrease of 10°C from the bottom of the well to the wellhead. To account for potential reservoir cooling effects, temperature drawdown factor was incorporated, resulting in a 0.2% reduction in the reference case, 0.3% in the pessimistic case, and 0.1% in the optimistic case.

Furthermore, the constraint of the minimum allowable reservoir temperature was applied ( $T_{min\_allowed}$ ). Specifically, the maximum allowable temperature decline adhered to a default correlation derived from a curve fitting analysis of end-of-life temperatures based on the 1996 EPRI study, sourced from the GETEM methodology [174]. The modelling of the maximum allowable temperature decline,  $\Delta T_{decline}$  (°C) is outlined in Equation (6.115). The reservoir temperature is monitored annually throughout the project's lifespan, and if it falls below  $T_{min\_allowed}$  (according to Equation (6.116)), the well is scheduled for replacement. However, should such a scenario arise within the final five years of the project, well replacement is not considered.

$$\Delta T_{decline} = 0.21 \cdot T_{res,initial} - 12.2 , \quad (6.115)$$

$$T_{min\_allowed} = T_{res,initial} - \Delta T_{decline} , \quad (6.116)$$

where  $T_{res,initial}$  represents the initial reservoir temperature in [°C].

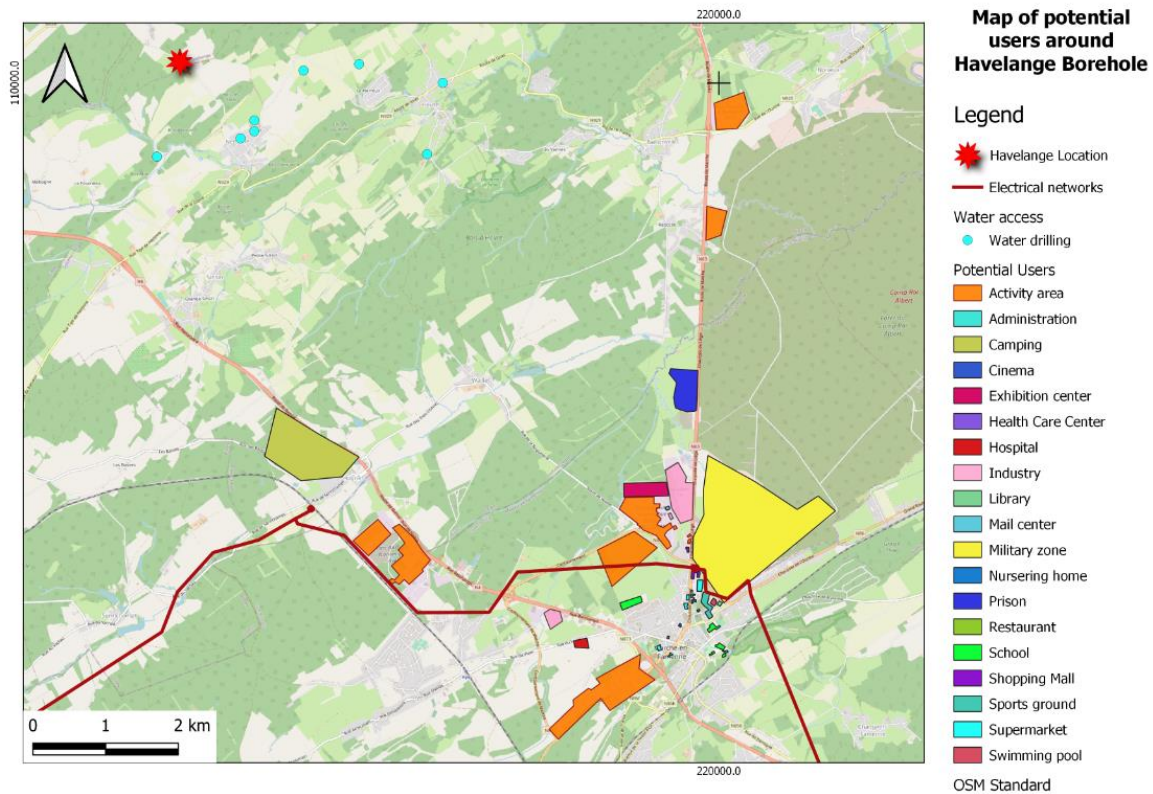

Figure 6.28. Map of Havelange demonstration site with listed potential end-users (source: provided by Horizon 2020 MEET project partners from Havelange site)

### 6.7.1.3. Electricity generation scenario

The main input parameters for electricity generation scenario are shown in Table 6.8. The data that was not available from the Havelange site was estimated based on the analogue sites and in concordance with experts working on Havelange site. In the optimistic case, the reinjection temperature is deliberately reduced to allow for the utilization of a wider temperature range, thus maximizing the potential benefit. Vice versa, in the pessimistic case, the reinjection temperature was increased to compensate for potentially unfavourable geological conditions that might hinder geothermal exploitation. It's a strategic adjustment to adapt to the circumstances.

It's worth noting that certain key parameters remain consistent across all three scenarios, including the distance from the electricity network, the availability of the power plant, and the timing of maintenance activities. These factors are held constant to ensure a fair and accurate comparison among the different cases.

Table 6.8. Main input parameters for the electricity generation scenario

Parameter	Reference case	Optimistic case	Pessimistic case
Usage	Power generation	Power generation	Power generation
Flow rate (total)	0.03 m <sup>3</sup> /s	0.04 m <sup>3</sup> /s	0.02 m <sup>3</sup> /s
Depth of production wells	5,000 m	5,000 m	5,000 m
Wellhead temperature	97°C	111°C	83°C
Reinjection temperature	60°C	55°C	60°C
Temperature drawdown	0.2°C	0.1°C	0.3°C
Distance to the electricity network	6,500 m	6,500 m	6,500 m
Power plant availability	90%	90%	90%
Month of maintenance	July	July	July

In the Table 6.9, the data regarding the power and cost of production and injection pumps are shown. For the production and injection pump used for the calculation in this deliverable, the methodology developed in [321] within the MEET project for the production and injection pump design is used. The mentioned methodology enables the estimation of pump power in the dependence of the fluid flow and corresponding pressures in the well, as well as on the surface.

For the conduction of evaluation of geothermal potential, a production well is required alongside with the existing injection well, it is considered that the production well will be the same depth as the injection well. Despite the well depth, a check-up for the installation of the production pump is conducted using the pressure gradient of 10 MPa/km, and with the calculated reservoir pressure, it is concluded that there is no need for the production pump installation [8]. Regarding the injection pump, a consistent type of injection pump is installed for all three cases. The pump operates at varying speeds and, consequently, consumes varying amount of power to accommodate the specific flow requirements. For the reference case, the corresponding cumulative flow is divided into two streams which flows into two injection pumps, arranged in parallel, each of 130 kW of installed power. For the optimistic case, the corresponding cumulative flow is divided into two streams and directed into two injection pumps, arranged in parallel and each of the with the 100 kW of power. For the pessimistic scenario, for the 0.02 m<sup>3</sup>/s flow, there is only one injection pump with 100 kW of power. The difference in pump power is explained with different pump speed, i.e., pump running at different efficiencies, and in different operating range of corresponding pump due to different pump speed.

Table 6.9. Production and injection pumps data

Parameter	Reference case	Optimistic case	Pessimistic case
ESP power	Not required	Not required	Not required
ESP cost	-	-	-
Injection pump power	130 kW	100 kW	100 kW
Number of injection pumps	2	2	1
Injection pump cost	50,660 €	43,280 €	43,280 €

The capital costs for each scenario are shown in Table 6.10. Notably, the pessimistic case exhibits the lowest capital investment in [€], followed by the optimistic and reference cases, which have approximately equivalent capital costs.

When assessing capital investment on a per kilowatt (kW) basis, the pessimistic case emerges as the highest, with a capital cost of 217,254 €/kW. In contrast, the reference case follows with 77,816 €/kW, and the optimistic case has the lowest capital cost 35,330 €/kW.

These variations in capital costs are primarily attributed to differences in the installed capacity of the power plant and associated auxiliary equipment. It's important to note that the expenses related to leasing, drilling, and completing production and injection wells, as well as simulation costs, remain consistent across all scenarios.

Table 6.10. Capital costs for electricity generation scenario

Parameter	Reference case	Optimistic case	Pessimistic case
Leasing	1,430,000 €	1,430,000 €	1,430,000 €
Additional cost	4,095,000 €	4,095,000 €	4,095,000 €
Production well cost	11,457,000 €	11,457,000 €	11,457,000 €
Injection well cost	0 €	0 €	0 €
Stimulation cost	2,000,000 €	2,000,000 €	2,000,000 €
ORC unit	303,870 €	492,370 €	162,670 €
Cold loop ancillaries	36,464 €	59,000 €	19,520 €
Dry cooler	60,774 €	98,500 €	32,534 €
Container housing	75,967 €	123,100 €	40,670 €
Start-up commissioning	22,790 €	36,930 €	12,200 €
Pipes	260,000 €	260,000 €	260,000 €
Injection pumps	101,320 €	86,560 €	43,280 €
TOTAL	19,843,185 €	20,138,460 €	19,552,874 €

Specific costs associated with O&M costs for each case are summarized in Table 6.11. Maintenance costs consist of wellfield maintenance costs and power plant maintenance costs and vary with the installed capacity of the power plant. Labour costs also depend on the installed capacity. Power plant operating costs are directly related with the parasitic load, i.e., with the energy consumption from the production and injection pumps.

Table 6.11. Operational and maintenance cost for each case in electricity generation scenario

Parameter	Reference case	Optimistic case	Pessimistic case
Maintenance cost	23,030 €/year	37,317 €/year	12,328 €/year
Labour	31,950 €/year	48,943 €/year	16,170 €/year
Power plant operating cost	0.00025 €/kWh	0.0001 €/kWh	0.0004 €/kWh

Financial parameters used in the financial analysis are shown in Table 6.12. Same financial parameters were used for all modelled and evaluated cases.

Table 6.12. Financial parameters used in the financial analysis

<b>Parameter</b>	<b>All cases</b>
Discount rate	5.419 %
Inflation rate	1.5 %
Insurances (of installed costs)	3 %
Effective tax rate	25 %
Electricity selling price	100 €/MWh <sub>e</sub>
Capacity based incentive	6,370,000 €

#### 6.7.1.3.1. Analysis of results

The results of comprehensive analysis are presented in Table 6.13, and they offer valuable insights. It can be concluded that, from a technological standpoint, only the optimistic case demonstrates feasibility, as it successfully meets the total parasitic load of the production facility. As expected, the optimistic case boasts the highest installed capacity, which, in turn, covers all auto-consumption requirements and generates the most substantial quantity of electricity (as depicted in Figure 6.29).

In contrast, both the reference and pessimistic cases, despite the modelled conditions and applied constraints, fall short in covering the total auto-consumption needs of pumps and other auxiliary equipment. Consequently, in these cases, the net electricity generated is negative, as evidenced in Figure 6.30 and Figure 6.32.

It's noteworthy that in the pessimistic case, the operational phase lasts only 22 years (Figure 6.32), compared to 30 years in the reference and optimistic cases (Figure 6.30 and Figure 6.31). This discrepancy is attributed to the anticipated annual temperature drawdown, leading to a decline in reservoir temperature and, consequently, wellhead temperature below the minimum allowed threshold. The maximum allowable temperature decline is determined based on a default correlation derived from a curve fit analysis of end-of-life temperatures from the 1996 EPRI study, sourced from the GETEM methodology [174]. This modelling follows Equation (6.112). The reservoir temperature is monitored annually throughout the project's lifespan, and if it falls below  $T_{min\_allowed}$  (according to Equation (6.113)), well replacement is mandated. However, should this occur within the final five years of the project, no well replacement is carried out.

The variations in electricity production stem from the different exploitable temperature ranges. In the reference case, the temperature differential in the Organic Rankine Cycle (ORC) stands at approximately 40°C. In the optimistic case, a larger temperature difference of 55°C in the ORC enables the covering of auto-consumption and the generation of net

electricity. Conversely, in the pessimistic case, with a temperature difference of around 25°C in the ORC, electricity production falls short of covering all auto-consumption.

An interesting observation is the lowest Levelized Cost of Electricity (LCOE) in the optimistic case, primarily attributable to the highest net generated electricity.

Furthermore, the net present value (NPV) for each case has shown a negative value, underscoring the need for financial support, such as initial capital incentives or production subsidies, for such projects to be financially viable. Based on the obtained results, it is evident that the most feasible scenario is the optimistic case, as it exhibits the lowest LCOE over the project's duration, along with the highest electricity generation and reduced CO<sub>2</sub> emissions. However, it's essential to note that even in the optimistic case, the LCOE remains substantially higher than the average wholesale electricity price in Belgium for the year 2021 [322] (as depicted in Figure 6.33). Therefore, the scenario of electricity production alone should, for now, be regarded as suboptimal, and additional incentives or subsidies may be necessary to enhance the economic feasibility of such a project.

Table 6.13. Analysis results of each case in electricity generation scenario

Parameter	Reference case	Optimistic case	Pessimistic case
Installed electricity capacity	255 kW	570 kW	90 kW
Total produced electricity	47,168 MWh	107,648 MWh	11,918 MWh
LCOE	832.00 €/MWh	363.66 €/MWh	2,339.63 €/MWh
Total avoided CO <sub>2</sub> emissions	22,675 tonnes	51,748 tonnes	5,729 tonnes

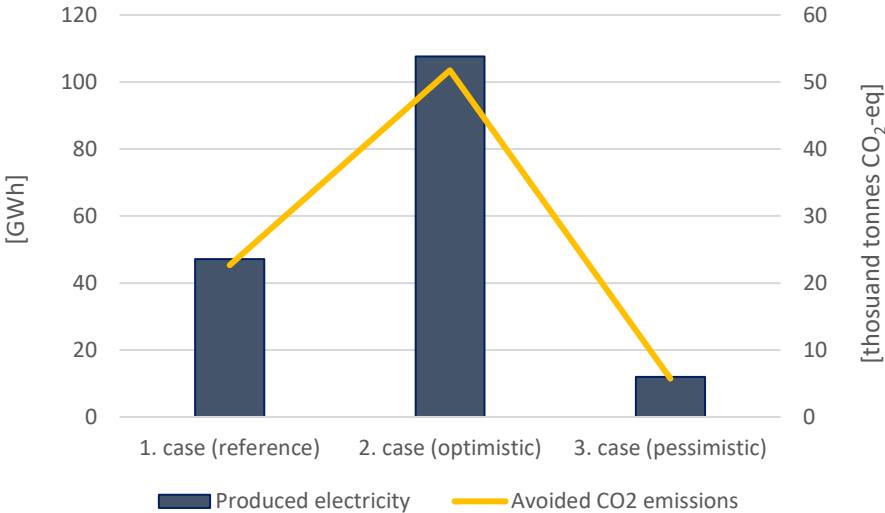

Figure 6.29. Total lifetime produced electricity and avoided CO<sub>2</sub> emissions for each case

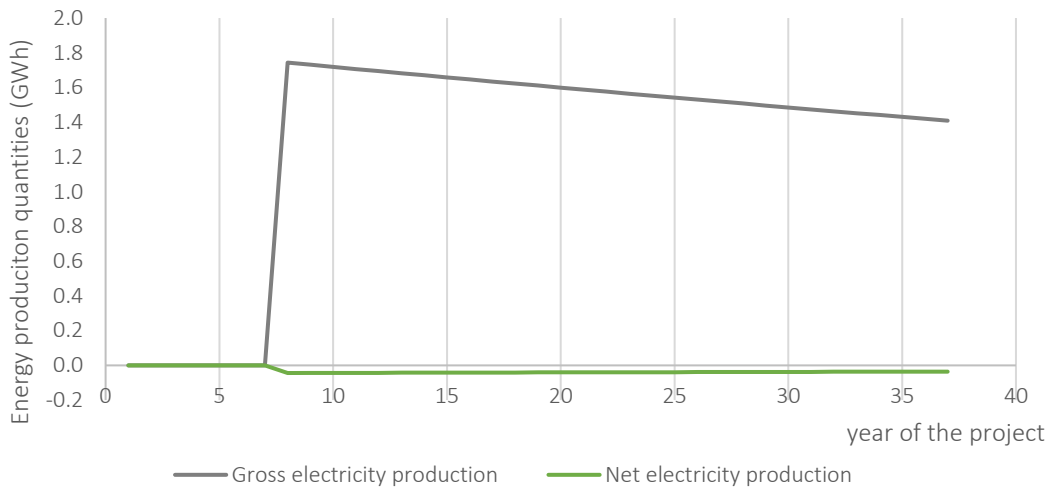

Figure 6.30. Lifetime gross and net electricity production (Reference case)

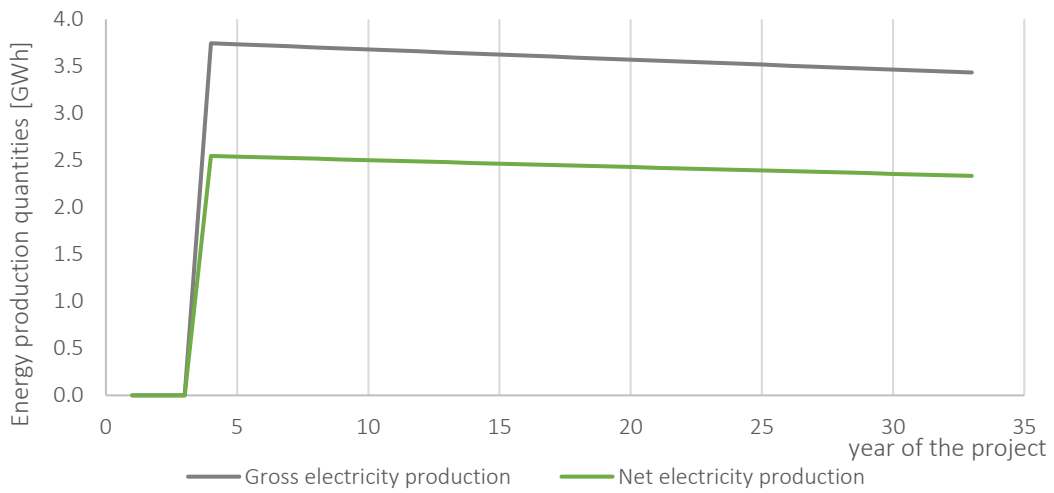

Figure 6.31. Lifetime gross and net electricity production (Optimistic case)

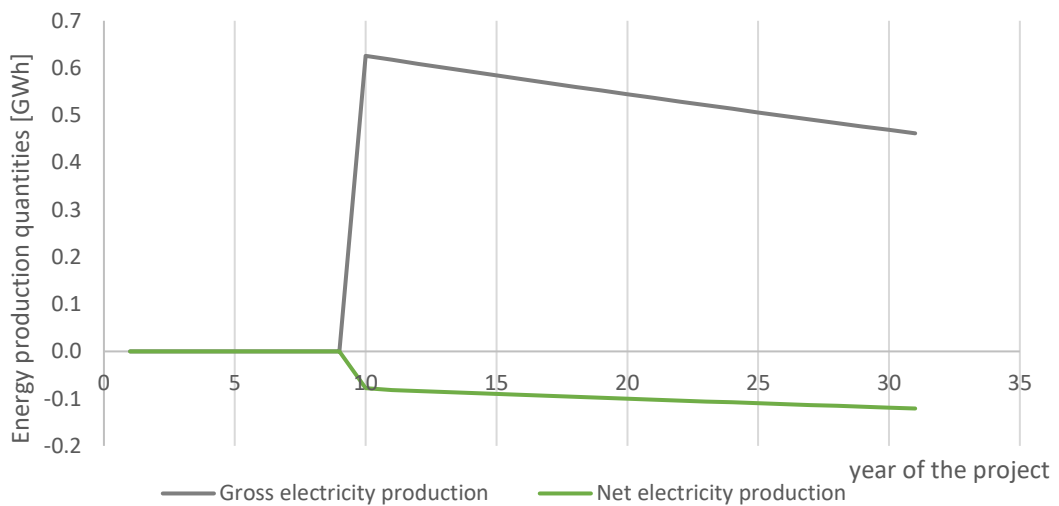

Figure 6.32. Lifetime gross and net electricity production (Pessimistic case)

As it can be seen from Figure 6.30, Figure 6.31, and Figure 6.32 only in case of optimistic scenario the wellhead temperature, and consequently the  $\Delta T$  between wellhead temperature



and injection temperature is sufficient enough to cover both auto-consumption of injection pumps and to enable net electricity generation which can then be sold.

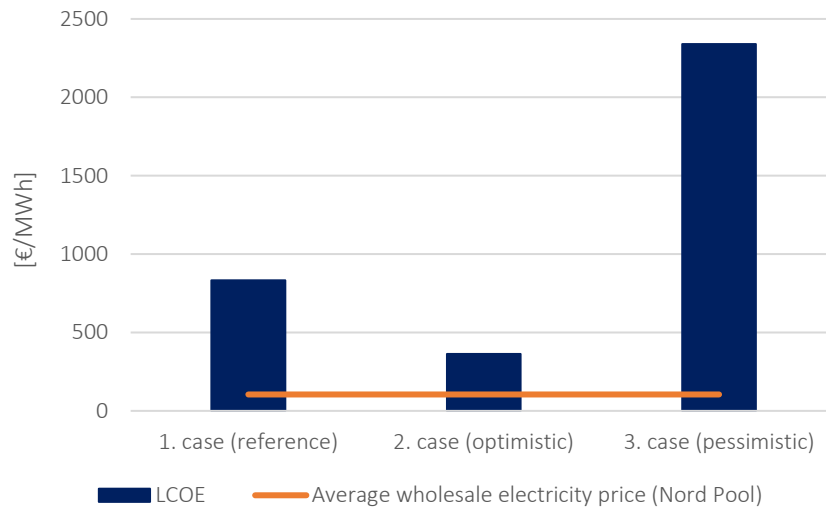

Figure 6.33. LCOE for each scenario in comparison with average wholesale electricity price for 2021 for Belgium

#### 6.7.1.4. District heating scenario

The main input data for district heating scenario are shown in Table 6.14. The assumptions are the same as for the electricity generation scenario.

Table 6.14. Input parameters for the district heating scenario

Parameter	Reference case	Optimistic case	Pessimistic case
Usage	Camp heating	Camp heating	Camp heating
Flow rate (total)	0.03 m <sup>3</sup> /s	0.04 m <sup>3</sup> /s	0.02 m <sup>3</sup> /s
Depth of production wells	5,000 m	5,000 m	5,000 m
Wellhead temperature	97°C	111°C	83°C
Reinjection temperature	70°C	55°C	65°C
Temperature drawdown	0.2°C	0.1°C	0.3°C
Distance to the heating network	5,000 m	5,000 m	5,000 m
Power plant availability	90%	90%	90%
Month of maintenance	July	July	July

Secondary loop characteristics for realistic case which reflect the heating needs throughout the year are presented in Figure 6.34 and Figure 6.35. Namely, Figure 6.34 shows monthly values of supply ( $T_{in}$ ) and return ( $T_{out}$ ) temperatures changes and Figure 6.35 shows monthly values of mass flow changes. The supply and return temperatures as well as the mass flow, i.e., heat needs for optimistic case, are shown on the Figure 6.36 and Figure 6.37. The increase of the mass flow in the mentioned case derives from calculating the maximum capacity of heat production without having unsatisfied heat demand and it is also based on the average outside air temperatures (Figure 6.40). The secondary loop characteristics for the pessimistic case are shown in Figure 6.38 and Figure 6.39.

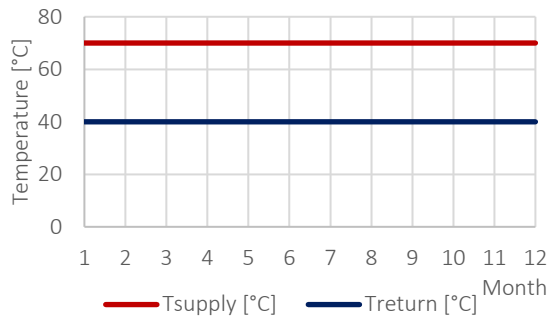

Figure 6.34. District heating supply and return temperatures of reference case

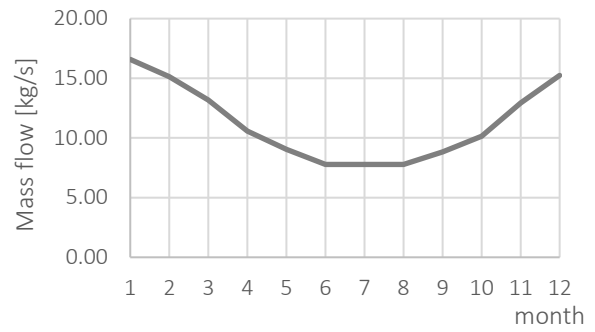

Figure 6.35. District heating mass flow of reference case

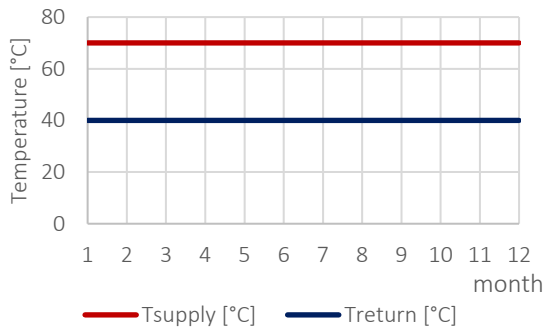

Figure 6.36. District heating supply and return temperatures of optimistic case

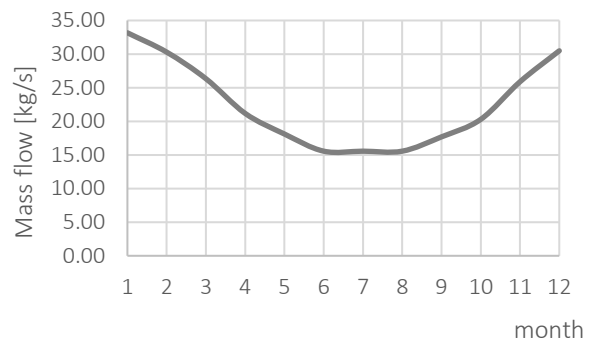

Figure 6.37. District heating mass flow of optimistic case

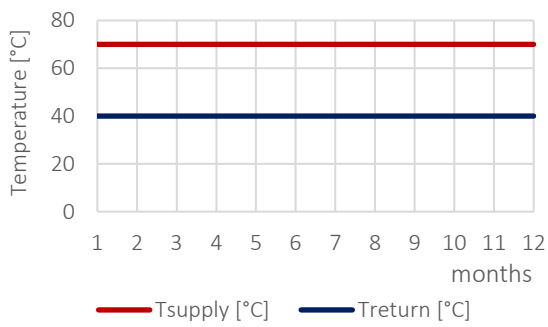

Figure 6.38. District heating supply and return temperatures of pessimistic case

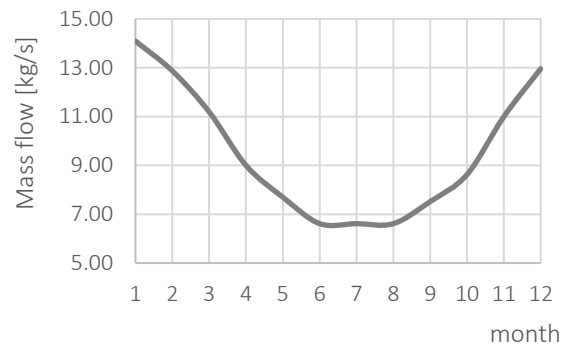

Figure 6.39. District heating mass flow of pessimistic case

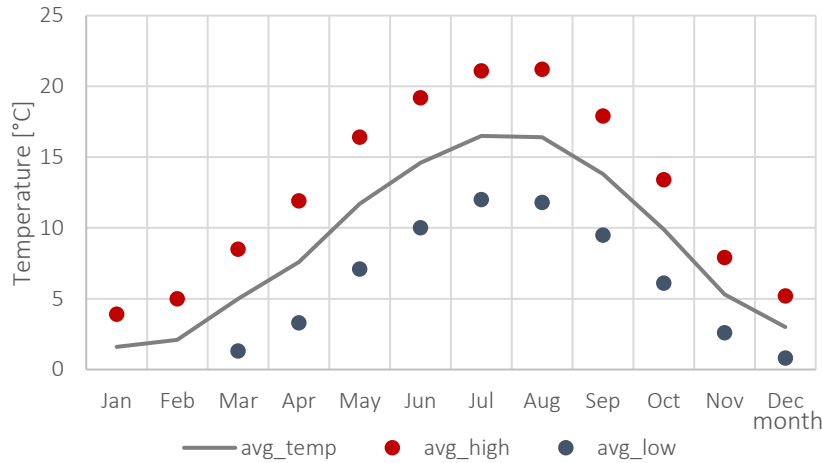

Figure 6.40. Monthly average outside air temperature (for Belgium)

The main characteristics of production and injection pumps, along with their costs are the same as in the electricity generation scenario, as summarized in Table 6.9.

In the context of the district heating scenario, the capital costs for each case are presented in Table 6.15. Notably, the lowest capital investment in [€] is associated with the pessimistic case, followed by a slightly higher capital cost for the reference case. In contrast, the optimistic case incurs the highest investment cost, which can be attributed to the substantial installed capacity of the thermal plant. When considering capital investment per kilowatt [kW], the pessimistic case again emerges with the highest capital cost at 12,826 €/kWh. The reference case follows with 10,935 €/kWh, while the optimistic case exhibits the lowest capital cost 5,481 €/kW. This variation in costs primarily arises from disparities in production quantities, as the capital investment costs themselves are comparable across all three cases. Additionally, the plant equipment cost depended on the installed capacity and the ‘six tenth rule’ was used to evaluate these costs for each case. Costs for the pipes are the same for each scenario since the length remains the same in each case.

Table 6.15. Capital costs for district heating scenario

Parameter	Reference case	Optimistic case	Pessimistic case
Leasing	1,430,000 €	1,430,000 €	1,430,000 €
Additional cost	4,095,000 €	4,095,000 €	4,095,000 €
Production well cost	11,457,000 €	11,457,000 €	11,457,000 €
Injection well cost	0 €	0 €	0 €
Stimulation cost	2,000,000 €	2,000,000 €	2,000,000 €
Heating plant equipment	144,109 €	218,550 €	130,792 €
Pipes	4,830,000 €	4,830,000 €	4,830,000 €
Production pump	0 €	0 €	0 €
Injection pumps	101,320 €	86,560 €	43,280 €
<b>TOTAL</b>	<b>24,057,429 €</b>	<b>24,117,110 €</b>	<b>23,986,072 €</b>

Individual O&M costs are calculated as described in electricity generation scenario and are summarized in Table 6.16.

Table 6.16. Operational and maintenance cost for each case in district heating scenario

Parameter	Reference case	Optimistic case	Pessimistic case
Maintenance cost	180,618 €/year	273,914 €/year	163,926 €/year
Labour	110,004 €/year	166,825 €/year	99,838 €/year
Power plant operating cost	0.007 €/kWh	0.005 €/kWh	0.009 €/kWh

Financial parameters that were used for the economic analysis are shown in the Table 6.17. Same financial parameters were used for all modelled and evaluated cases.

Table 6.17. Financial and economic parameters used in the economic analysis

Parameter	All cases
Discount rate	5.419 %
Inflation rate	1.5 %
Effective tax rate	25 %
Insurances (of installed costs)	3 %
(initial) Heat selling price	65 €/MWh <sub>th</sub>
Capacity based incentive	6,370,000 €

#### 6.7.1.4.1. Analysis of results

The results of analysis are presented in Table 6.18. It can be concluded that all three cases are technologically feasible, as they successfully meet the total heat requirements in their respective scenarios. As anticipated, the optimistic case exhibits the highest installed capacity, effectively covering all heat demands, just like the reference and pessimistic cases, and it generates the largest quantity of heat energy (as depicted in Figure 6.41).

It's worth noting that in the pessimistic case, the operational phase is shorter, lasting only 23 years (Figure 6.44), compared to 30 years in the reference and optimistic cases (Figure 6.42 and Figure 6.43). This discrepancy is accounted for due to the expected annual temperature drawdown, leading to a decline in reservoir temperature and, consequently, wellhead temperature below the minimum allowable threshold. The maximum allowable temperature decline is determined based on a default correlation derived from a curve-fit analysis of end-of-life temperatures from the 1996 EPRI study, sourced from the GETEM methodology [174]. This modelling follows Equation (6.115). The reservoir temperature is monitored annually throughout the project's lifespan, and if it falls below  $T_{min\_allowed}$  (according to Equation (6.116)), well replacement is mandated. However, should this occur within the final five years of the project, no well replacement is carried out.

As demonstrated in the table, the optimistic scenario results in the most significant reduction in the Levelized Cost of Heating (LCOH). Additionally, the net present value

(NPV) for each case indicates negative values, highlighting the need for financial support, such as initial capital incentives or production subsidies, to make such projects financially viable.

Based on the output results, it is apparent that the most feasible scenario is the optimistic case, as it exhibits the lowest LCOH value over the project's duration, along with the highest energy production and reduced CO<sub>2</sub> emissions. However, it's important to note that even in the optimistic case, the LCOH remains substantially higher than average low and average high costs of heat from gas boilers in Belgium for year 2021 (Figure 6.45). Therefore, the scenario of district heating should, for now, be considered as a viable option, and additional incentives or subsidies may be necessary to enhance the economic feasibility of such a project.

Table 6.18. Analysis results of each case in district heating scenario

Parameter	Reference case	Optimistic case	Pessimistic case
Installed capacity - heat	2,200 kW	4,400 kW	1,870 kW
Total produced heat	335,189 MWh	670,377 MWh	218,431 MWh
Total unsatisfied heat demand	0 MWh	0 MWh	0 MWh
LCOH	224.66 €/MWh	115.00 €/MWh	318.7 €/MWh
Total avoided CO <sub>2</sub> emissions	75,542 tonnes	151,083 tonnes	64,210 tonnes

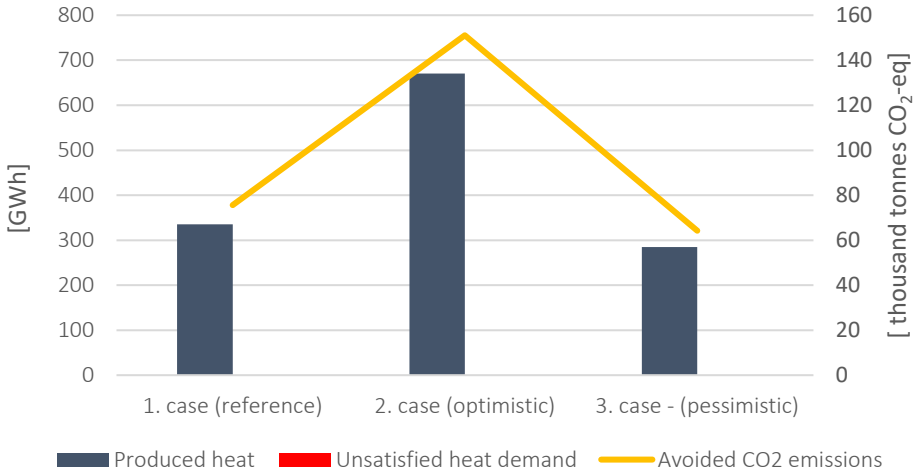

Figure 6.41. Total lifetime produced heat, unsatisfied heat demand, and avoided CO<sub>2</sub> emissions for each case

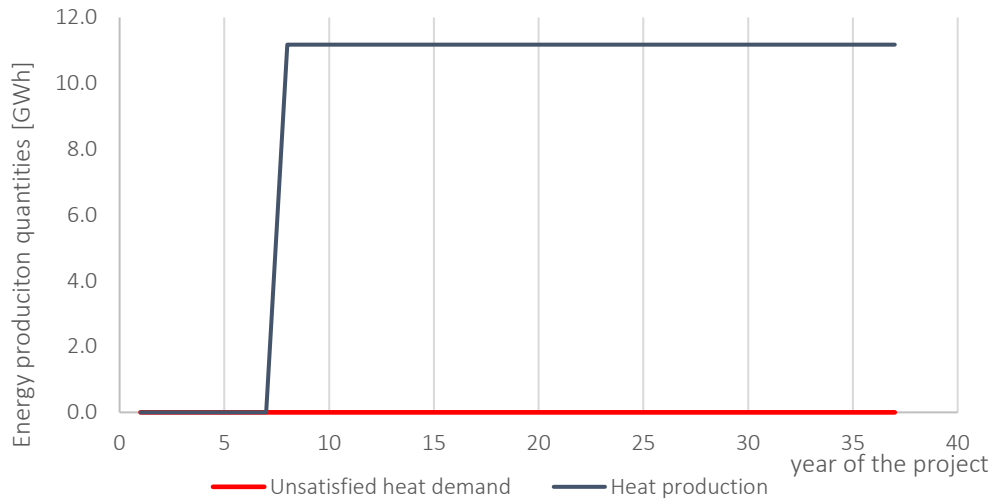

Figure 6.42. Lifetime heat production and unsatisfied heat demand (Reference case)

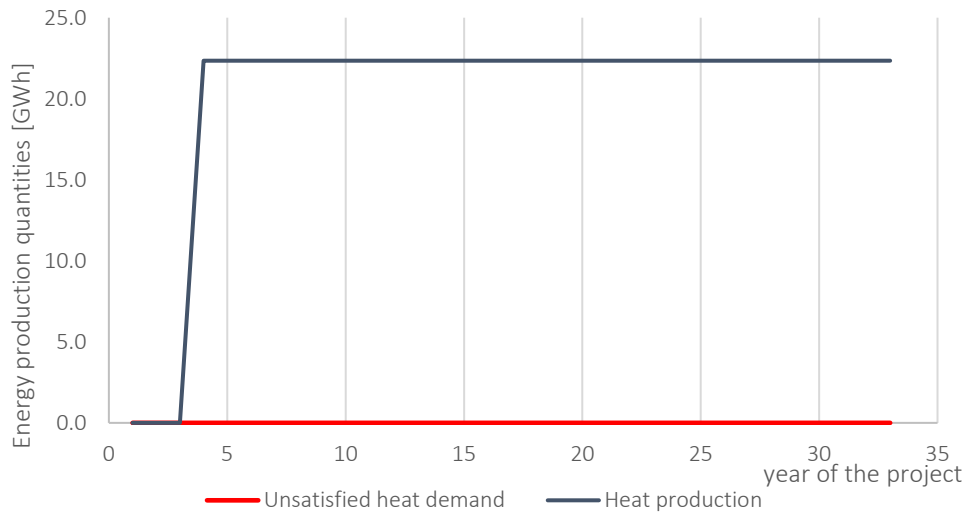

Figure 6.43. Lifetime heat production and unsatisfied heat demand (Optimistic case)

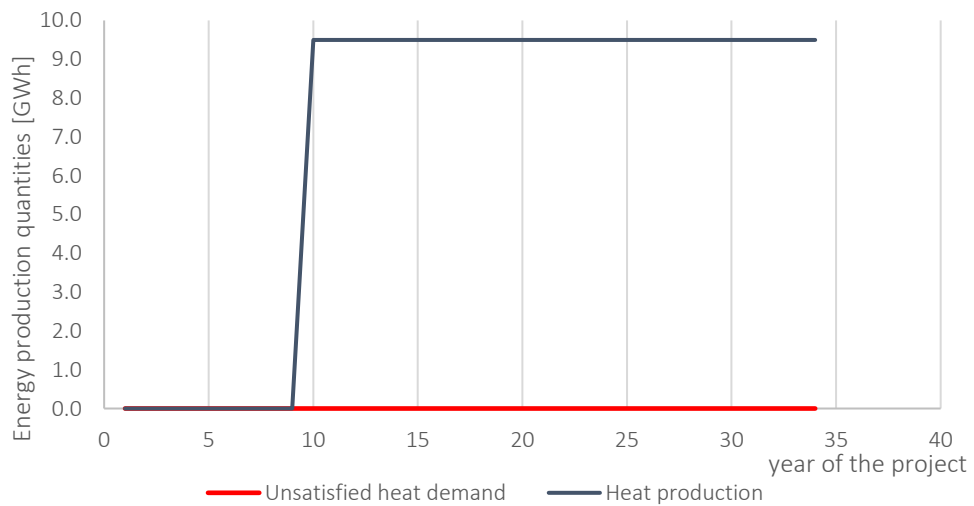

Figure 6.44. Lifetime heat production and unsatisfied heat demand (Pessimistic case)

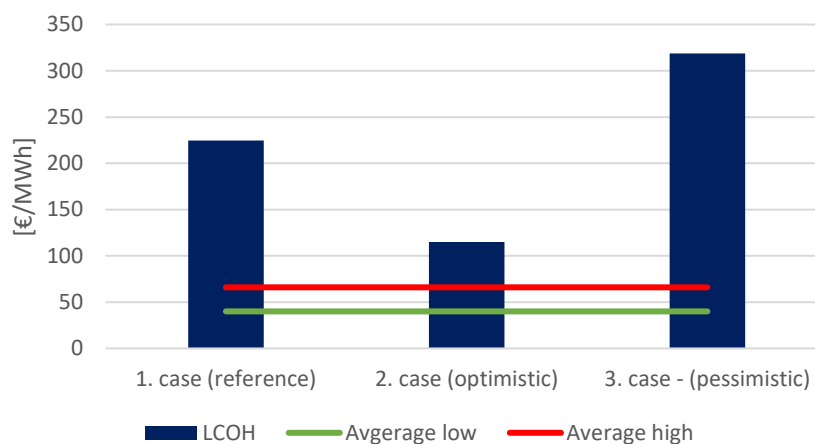

Figure 6.45. LCOH for each case in comparison with the average low and average high costs of heat from gas boilers in Belgium for year 2021

### 6.7.1.5. CHP scenario

The main input parameters for the power scenario are detailed in Table 6.19. In cases where data was unavailable directly from the Havelange site, estimates were made based on analogous sites and in consultation with experts working the Havelange site, in same was as for the district heating and electricity generation scenarios.

In the optimistic case, a deliberate reduction in reinjection temperature is implemented to broaden the temperature range available for geothermal utilization, thereby maximizing its potential benefits. Vice versa, in the pessimistic case, the reinjection temperature is elevated to compensate for potentially unfavourable geological conditions that could impede geothermal exploitation. This strategic adjustment is made to adapt to varying circumstances and optimize system performance.

It's important to highlight that certain critical parameters remain consistent across all three scenarios, which include the distance from the power grid, the availability of the power plant, and the scheduling of maintenance activities. These factors are intentionally held constant to ensure a fair and accurate comparison among the different cases, allowing for a clear evaluation of their respective outcomes.

Table 6.19. Input parameters for the combines heat and power scenario

Parameter	Reference case	Optimistic case	Pessimistic case
Usage	CHP	CHP	CHP
Flow rate (total)	0.03 m <sup>3</sup> /s	0.04 m <sup>3</sup> /s	0.02 m <sup>3</sup> /s
Depth of production wells	5,000 m	5,000 m	5,000 m
Wellhead temperature	97°C	111°C	83°C
Reinjection temperature	70°C	55°C	60°C
Temperature drawdown	0.2°C	0.1°C	0.3°C
Distance to the heating network	5,000 m	5,000 m	5,000 m
Distance to the electricity network	6,500 m	6,500 m	6,500 m
Power plant availability	90%	90%	90%
Month of maintenance	July	July	July

The secondary loop characteristic which reflect the heat needs throughout the year are same as for the district heating scenario shown in Figure 6.34 and Figure 6.35 for realistic scenario, Figure 6.36 and Figure 6.37 for optimistic scenario, and Figure 6.38 and Figure 6.39 for realistic scenario. In Figure 6.40 the monthly average outside temperatures for the Belgium are shown.

The main characteristics of production and injection pumps, along with their costs are the same as in the electricity generation scenario, as summarized in Table 6.9.

The capital costs for each case in the combined heat and power scenario are presented in Table 6.20. The costs associated with the ORC unit and its corresponding equipment are derived from the data provided by ENOGIA [311]. It's evident that the lowest capital investment in [€] is associated with the pessimistic case, followed by slightly higher capital costs for the optimistic and reference cases.

When assessing capital investment per kilowatt [kW], the pessimistic case emerges with the highest capital cost at 12,260 €/kW. The reference case follows with 9,878 €/kW, and the optimistic case exhibits the lowest capital cost 5,132 €/kW. This variation in costs primarily arises from differences in the installed capacity of the ORC unit and associated equipment, as the capital investment costs themselves are based on the same data source.

Table 6.20. Capital costs for combined heat and power production scenario

<b>Parameter</b>	<b>Reference case</b>	<b>Optimistic case</b>	<b>Pessimistic case</b>
Leasing	1,430,000 €	1,430,000 €	1,430,000 €
Additional cost	4,095,000 €	4,095,000 €	4,095,000 €
Production well cost	11,457,000 €	11,457,000 €	11,457,000 €
Injection well cost	0 €	0 €	0 €
Stimulation cost	2,000,000 €	2,000,000 €	2,000,000 €
Heating plant equipment	234,700 €	293,676 €	175,640 €
ORC unit	335,000 €	427,260 €	188,444 €
Cold loop ancillaries	40,200 €	51,270 €	22,610 €
Dry cooler	67,000 €	85,450 €	37,690 €
Container housing	83,750 €	106,815 €	47,110 €
Start-up commissioning	25,125 €	32,045 €	14,130 €
Pipes	4,826,000 €	4,826,000 €	4,826,000 €
Production pump	0 €	0 €	0 €
Injection pumps	101,320 €	86,560 €	43,280 €
<b>TOTAL</b>	<b>24,695,095 €</b>	<b>24,891,076 €</b>	<b>24,336,904 €</b>

Individual O&M costs are calculated as described in electricity generation scenario and are summarized in Table 6.21.

Table 6.21. Operational and maintenance cost for each case in combined heat and power production scenario

<b>Parameter</b>	<b>Reference case</b>	<b>Optimistic case</b>	<b>Pessimistic case</b>
Maintenance cost	206,103 €/year	301,762 €/year	178,207 €/year
Labour	110,064 €/year	166,825 €/year	99,838 €/year
Power plant operating cost	0.003 €/kWh	0.0025 €/kWh	0.0045 €/kWh



Financial parameters that were used for the economic analysis are shown in the Table 6.22. Same financial parameters were used for all modelled and evaluated cases.

Table 6.22. Financial and economic parameters used in the economic analysis.

<b>Parameter</b>	<b>All cases</b>
Discount rate	5.419 %
Inflation rate	1.5 %
Effective tax rate	25 %
Insurances (of installed costs)	3 %
(initial) Heat selling price	65 €/MWh <sub>th</sub>
Electricity selling price	100 €/MWh <sub>e</sub>
Capacity based incentive	6,370,000 €

#### 6.7.1.5.1. Analysis of results

The results of analysis are summarized in Table 6.23. It can be concluded that all three cases are technologically feasible, as they successfully meet the heat requirements in their respective scenarios. As anticipated, the optimistic case exhibits the highest installed thermal capacity, effectively covering all heat demands, similar to the reference and pessimistic cases, and it generates the largest quantity of heat energy.

When considering electricity generation, the optimistic case produces the greatest quantities of electricity, followed by the reference and pessimistic cases (as depicted in Figure 6.46).

The variations in electricity generation arise from the different exploitable temperature ranges. In the reference case (Figure 6.47), a temperature difference of 70°C in the ORC, utilizing the parallel configuration, enables the coverage of all heat demands and the generation of electricity for auto-consumption. In the optimistic case, utilizing the series configuration (Figure 6.48), a temperature difference of 50°C in the ORC enables covering auto-consumption and producing net electricity, which can be sold, while also meeting a higher heat demand compared to the reference and pessimistic cases. In the pessimistic case, utilizing parallel configuration (Figure 6.49), a temperature difference of 40°C in the ORC results in the lowest installed power among the cases.

When comparing the installed capacity of the ORC unit for electricity generation scenario versus the combined heat and power (CHP) option, it becomes evident that in the reference and pessimistic cases, the installed capacity is lower than that in the CHP option. This difference can be elucidated by the fact that the CHP configuration allows for a higher temperature differential between the brine inlet and outlet of the ORC. This is achieved through the parallel configuration, wherein the injection temperature is used as a constraint in calculations. Series configuration was not feasible from technological point of view. In the

case of CHP, this constraint is checked and compared to the temperature of the brine mixture, enabling a higher delta T for the ORC unit. On the other hand, in the scenario of electricity generation only, the injection temperature is checked and directly compared to the ORC brine outlet temperature, resulting in a lower value compared to the parallel CHP configuration.

The Levelized Cost of Electricity (LCOE) for all cases falls below average wholesale electricity prices in most European countries compared to the year 2021 (Figure 6.50). However, even though the Levelized Cost of Heating (LCOH) in the case of combined heat and power (CHP) production is lower than in the case of district heating scenario, it still remains relatively high and well above the average low and average high costs of heat from gas boilers (Figure 6.50).

Additionally, the net present value (NPV) for each case indicates negative values, highlighting the need for financial support, such as initial capital incentives or production subsidies, to make such projects financially viable.

Based on the output results, it can be concluded that the most feasible scenario is the optimistic case, as it exhibits the lowest LCOE and LCOH values over the project's duration, along with the highest thermal energy production and reduced CO<sub>2</sub> emissions. However, it's important to approach this with caution, as the conditions favouring the optimistic case have a lower probability of occurring. The results for the reference case, which is more probable, also show good results in terms of technological and economic feasibility. Nonetheless, at this stage of geothermal development, these projects should receive additional financial support to enhance their economic feasibility and competitiveness with other energy sources.

Table 6.23. Analysis of results for each case for combined heat and power production scenario

<b>Parameter</b>	<b>Reference case</b>	<b>Optimistic case</b>	<b>Pessimistic case</b>
Installed capacity - heat	2,200 kW	4,400 kW	1,870 kW
Total produced heat	335,189 MWh	670,377 MWh	218,431 MWh
Total unsatisfied heat demand	0 MWh	0 MWh	0 MWh
Installed electricity capacity	300 kW	450 kW	115 kW
Total produced electricity	67,693 MWh	106,766 MWh	26,573 MWh
LCOE	27.87 €/MWh	15.11 €/MWh	68.34 €/MWh
LCOH	217.13 €/MWh	93.18 €/MWh	254.74 €/MWh
Total avoided CO <sub>2</sub> emissions	637,319 tonnes	1,229,364 tonnes	492,736 tonnes

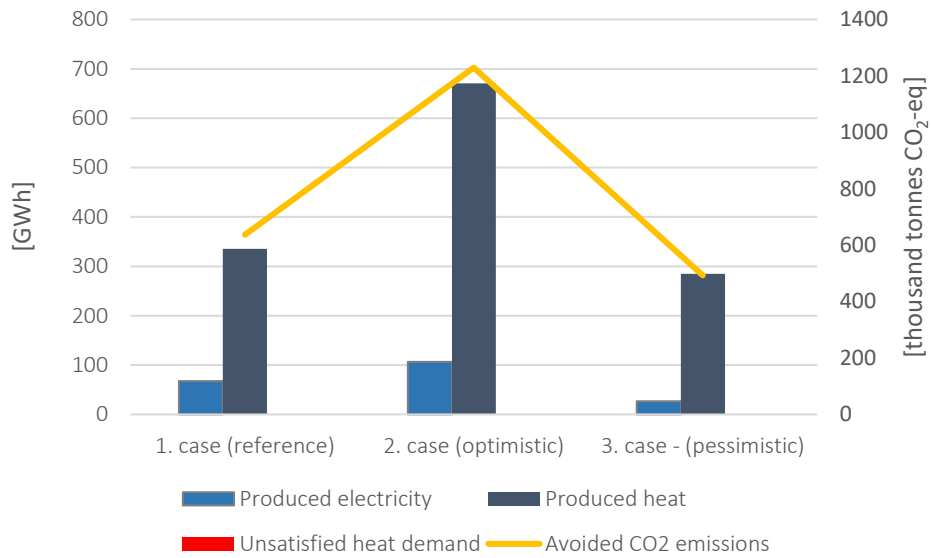

Figure 6.46. Total lifetime produced electricity, heat, unsatisfied heat demand, and avoided CO<sub>2</sub> emissions for each case

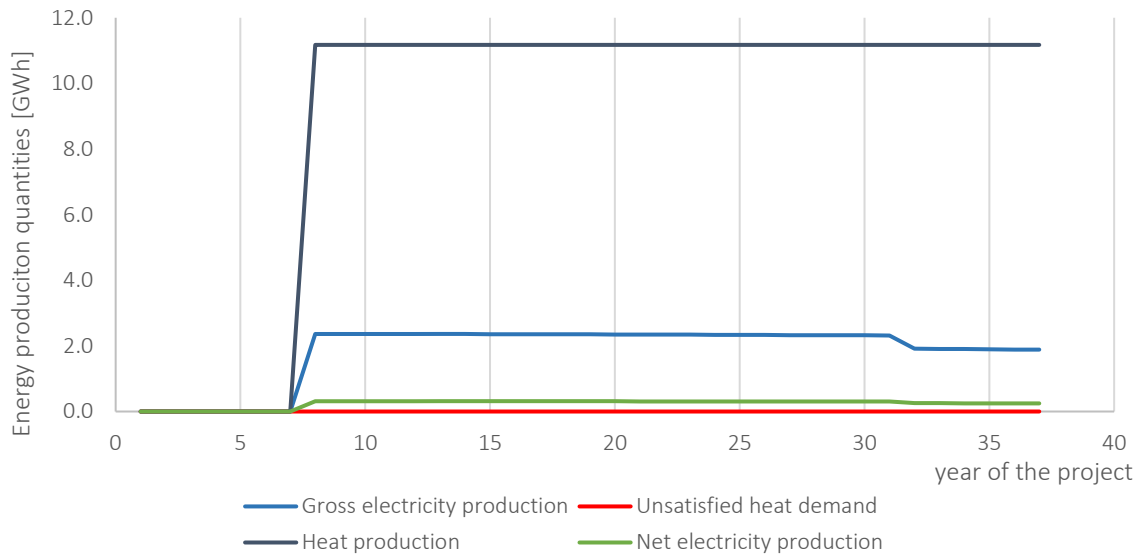

Figure 6.47. Lifetime heat and electricity production and unsatisfied heat demand (Reference case)

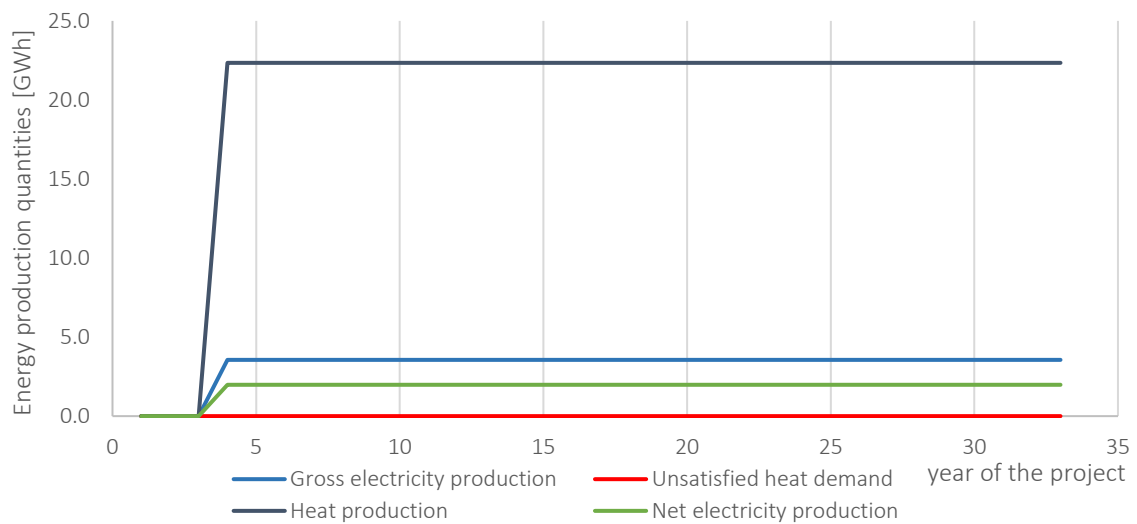

Figure 6.48. Lifetime heat and electricity production and unsatisfied heat demand (Optimistic case)

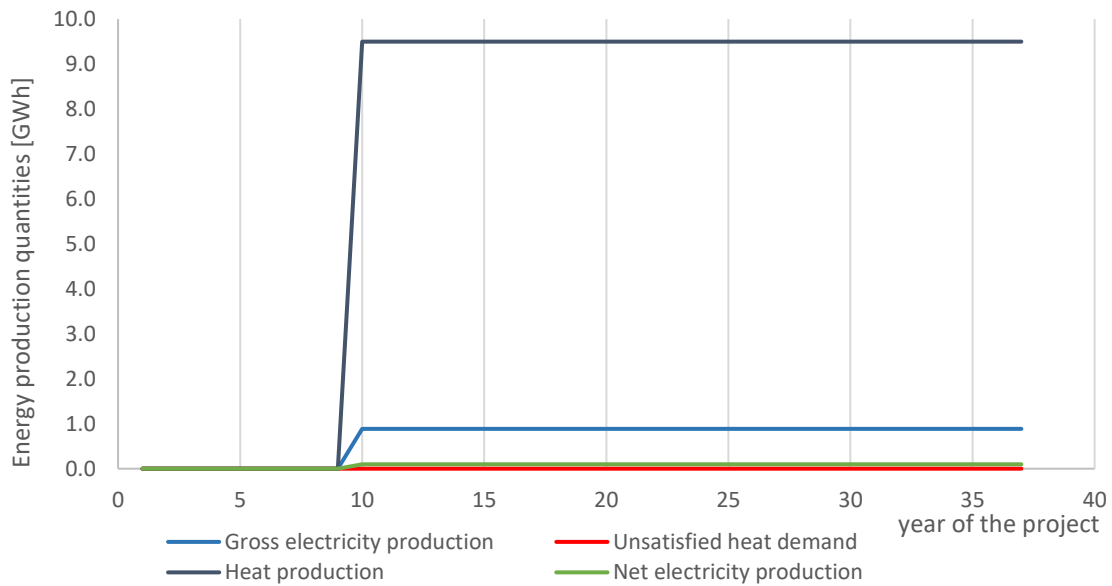

Figure 6.49. Lifetime heat and electricity production and unsatisfied heat demand (Pessimistic case)

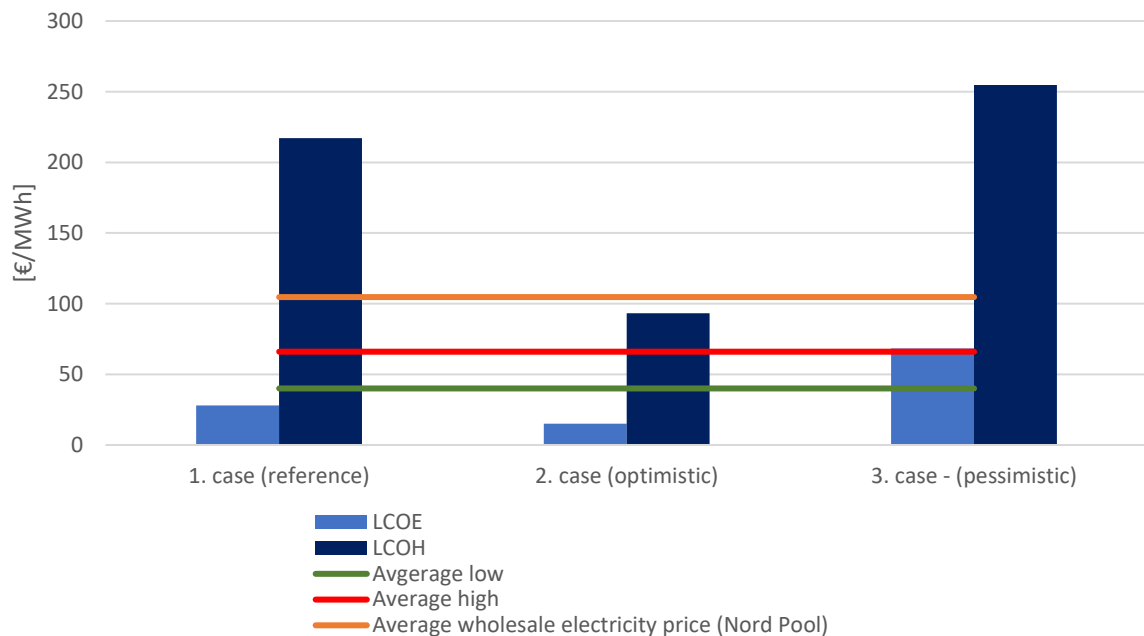

Figure 6.50. LCOE for each scenario in comparison with average wholesale electricity price and LCOH for each case in comparison with the average low and average high costs of heat from gas boilers in Belgium for year 2021

### 6.7.2. Comparison of development of EGS project at different geothermal sites

reservoir's rock types based on different geological settings were chosen for the analysis and are as follows. On the Figure 6.51 and in Table 6.24 the sites which replicate the stated reservoir rocks are shown:

- Sedimentary rocks;
- Meta-sedimentary rocks; and
- Crystalline rocks.



Figure 6.51. Potential geothermal sites in various geological settings chosen for the analysis

Table 6.24. Classification of analysed sites according to their reservoir rock type

<b>Demonstration site</b>	<b>Reservoir's rock type</b>
Cazaux (France)	Sedimentary rocks
Havelange (Belgium)	Meta-sedimentary rocks
UDDGP (UK)	Crystalline rocks

The rocks encountered at the Havelange site present a unique opportunity for exploring the deep structure of Lower Devonian formations within the external Variscan fold-and-thrust belt. This site is situated at a considerable distance from any younger extensional structures and is positioned in the central part of the Dinant Synclinorium, which is a regional unit within the Rhenohercynian fold-and-thrust belt in Belgium. The existing infrastructure at the selected site comprises a deep borehole, which was drilled to a depth of 5,648 meters during the early 1980s. This exploration well was originally aimed at assessing potential gas resources that might be trapped beneath the main Variscan external thrust, known as the Midi-Eifel Fault. Remarkably, it remains the deepest borehole in Belgium. Of particular significance are the quartzite members within the borehole, which exhibit permeability indicators associated with fractures. These quartzite formations were encountered at a depth of approximately 4.5 kilometres, with recorded temperatures reaching around 126°C. The

Havelange site is situated in a rural environment. Consequently, the options for harnessing energy are limited to meeting specific heat demands or pursuing electricity production targets.

The UDDGP site in Cornwall, United Kingdom, is situated in an area where acidic to intermediate intrusive rocks, such as granites, make up substantial portions of the subsurface. In some areas, these intrusive rocks are overlaid by a sequence of sediments. Consequently, the UDDGP site was chosen as a site specifically to study fractured crystalline rock types. One notable geological feature in this region is the Carnmenellis granite, which is a sub-circular composite intrusion and forms part of the Variscan Cornubian batholith. Additionally, the Porthtowan fault zone (PTF), which belongs to a family of NW-SE striking structures that cut across the southwestern region of England, is of significance. The PTF is a sub-vertical strike-slip fault zone that traverses both metamorphic rocks (known as killas) and granite formations. The presence of foliated and mylonitised granites provides evidence of the PTF being active during the emplacement of the granite. However, it's important to note that no ongoing or active movement along this fault has been documented.

Possible sites for sedimentary rocks are located in oil- and/or natural gas-bearing sedimentary basins of Mesozoic age. The Cazaux Purbeckian field was chosen for further analysis. It was discovered in 1961 and is located 3,200 m deep. Average temperature from single well is around 110°C at the surface with an average flow of 300 m<sup>3</sup>/d.

#### *6.7.2.1. Chosen sites' general information*

Main characteristics of chosen sites that are real measurements or estimated values based on experts' knowledge are presented in the Table 6.25.

The reliability level of economic and performance results that were obtained by using the evaluation model are highly dependent on the certainty level of input data. Therefore, for those sites where no or little geological and geophysical data and no reliable numerical reservoir and models exist, experts estimates or data from analogue sites was used. Additionally, since the status of each site differs from each other, available data is also different. Therefore, when analysing the results, one should consider that some data are real measurements and other are either evaluations based on real screenings, samples etc. or evaluations based on experts' knowledge of analogue sites.

Table 6.25. Main characteristics of chosen sites which replicate different geological settings

<b>Parameter</b>	<b>Sedimentary rocks</b>	<b>Meta-sedimentary rocks</b>	<b>Crystalline rocks</b>
Location	Teste de Buch (France)	Wallonia (Belgium)	Cornwall (UK)
Project status	In operation	Abandoned exploration well (natural gas)	Under development (stimulation, testing, plant construction)
Reservoir rock type	Sedimentary rocks	Meta-sedimentary rocks (paleozoic)	Crystalline (faulted granite)
Number of wells	23 production wells 10 injection wells	1 (exploration)	1 production well 1 injection well
Depth of wells	avg. 3,200 m	5,648 m	4,500 m (production) 2,000m (injection)
Production temperature	110°C	126°C	175°C (expected)
Reinjection temperature	55°C	not applicable	70°C (designed)
Flow rate	-	3.47 l/s (average well)	20 - 60l/s

### 6.7.2.2. *Analysis methodology*

The primary focus of this analysis was to identify economically feasible and viable projects among various EGS sites, each situated in different geological conditions and within the existing market environment.

After obtaining all performance and economic results, the multi-criteria decision-making analysis (MCDM) was done as described in Chapter 5, Section 5.3 and Section 5.4. Indeed, the Multi-Criteria Decision-Making (MCDM) feature within the evaluation model (and decision-support tool) provides a valuable platform for investors with diverse backgrounds and perspectives to assess geothermal projects, particularly with an emphasis on Enhanced Geothermal Systems (EGS). However, it's crucial to understand that the outcome of this evaluation is highly influenced by the preferences of the decision-maker, and as a result, it can exhibit significant variations. The decision-maker plays a major role in the evaluation process by assigning preferential rankings to the influencing criteria and alternatives. These rankings reflect the decision-maker's priorities and values, indicating which criteria are considered more important or critical for the assessment of the geothermal project. As a result, the final evaluation and ranking of different project alternatives can vary significantly based on the individual preferences and perspectives of the decision-maker. Generally, the MCDM acknowledges the inherent subjectivity in decision-making process and allows for a flexible and adaptable approach that encompasses the unique viewpoints and priorities of different stakeholders and investors. This flexibility is the key feature of MCDM, enabling a comprehensive and inclusive evaluation of geothermal projects that considers a broad range of factors and criteria deemed important by decision-makers.

The Analytic Hierarchy Process (AHP) has been conducted for several influencing groups such as geological setting, technology, economy/finance, society and environment. The

parameters within each group encompass the influencing factors required for the development of a geothermal project. The geological setting group of criteria was intentionally given the highest importance compared to other groups. Namely, the weights are obtained from the group of experts containing mostly geologists and geophysicists working in different fields. The purpose was to highlight the influence of different geological settings characteristics. Such decision environment should be taken with a certain carefulness having in mind that the geological setting characteristics are the main focus of this analysis, followed by economic criteria as shown in Figure 6.52. Any change in the ranking of the defined influencing criteria will result in different final grading of each demo site, and consequently slightly different conclusions. Obtained local weights for each influencing criteria in each group of criteria are shown in Figure 6.53 - Figure 6.57. The final (global) weights of each criterion are shown in Figure 6.58 where the emphasis is on the geological settings where it can be observed that the reservoir temperature, fluid specific heat capacity, permeability, etc., have the greatest influence when evaluating the geothermal project.

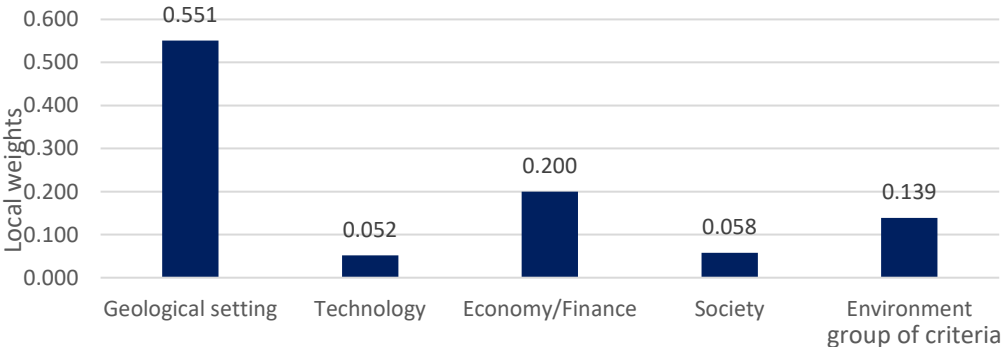

Figure 6.52. Obtained local weights of criteria groups

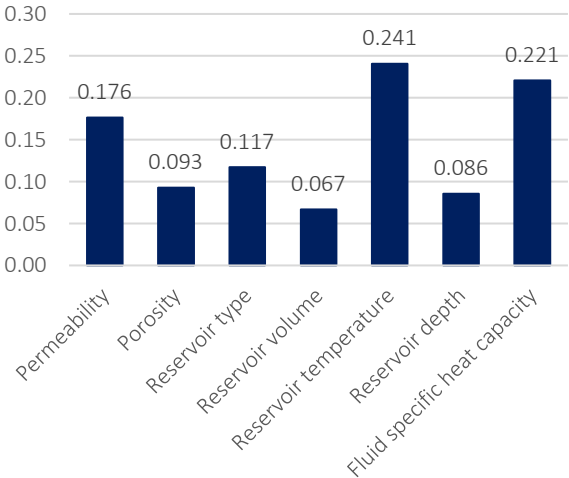

Figure 6.53. Obtained local weights in geological setting criteria group

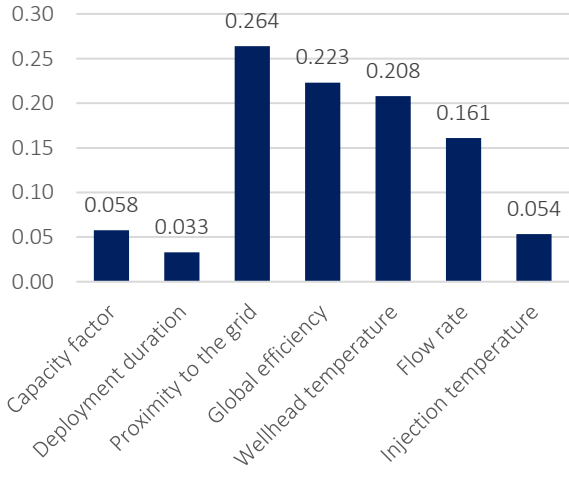

Figure 6.54. Obtained local weights in technology criteria group



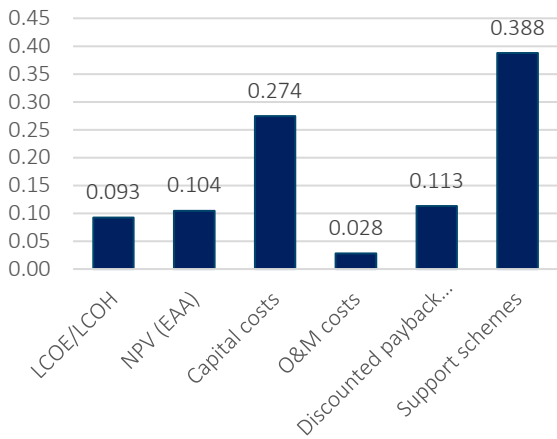

Figure 6.55. Obtained local weights in economic criteria group

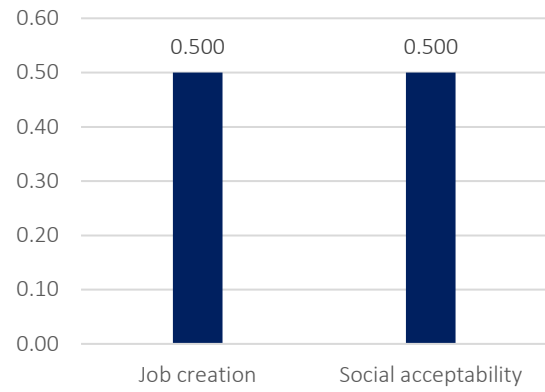

Figure 6.56. Obtained local weights in society criteria group

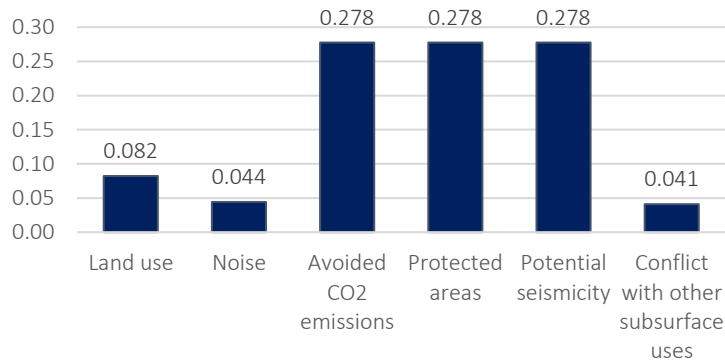

Figure 6.57. Obtained local weights in environment criteria group

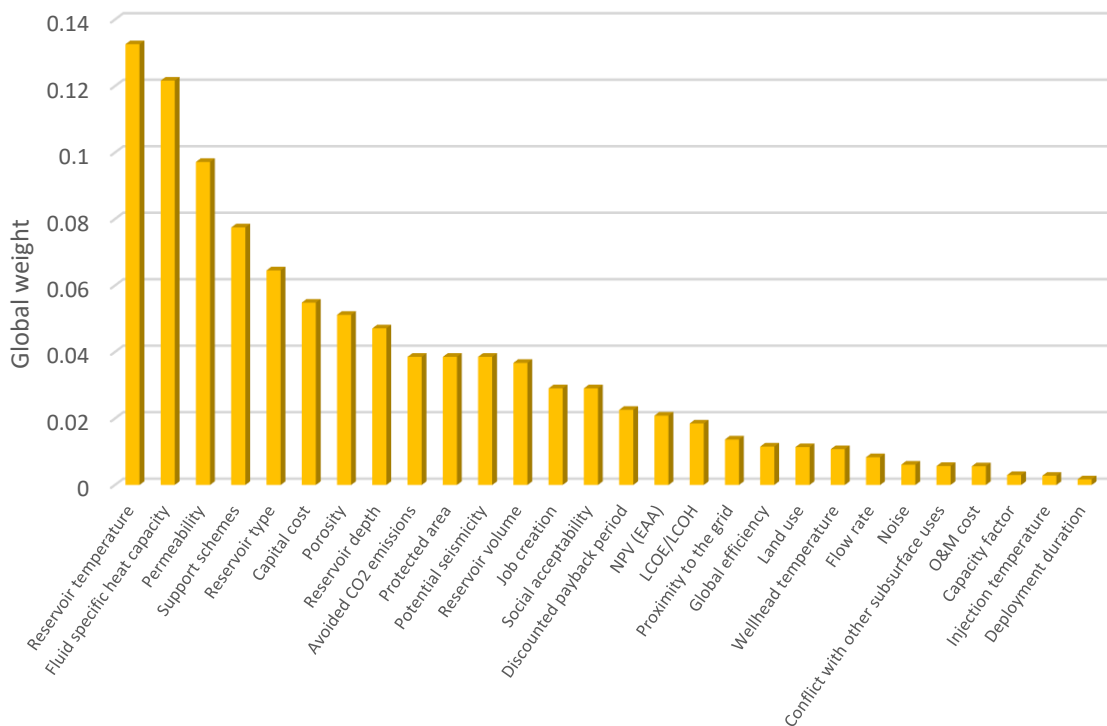

Figure 6.58. Sorted influencing factors of conducted AHP analysis (global weights of criteria)

To evaluate the diverse directions of geothermal energy potential development under varying geological conditions, three distinct scenarios were modelled and analysed for each demonstration site. These scenarios encompassed the following options: heat production scenario, electricity generation scenario, and combined heat and power production (CHP) scenario.

The geological input data for each demonstration site is provided in Table 6.26, providing essential information for the evaluation and comparison of these geothermal projects.

Table 6.26. Main geological data for each type of geological setting site

<b>Parameter</b>	<b>Sedimentary rocks</b>	<b>Meta-sedimentary rocks</b>	<b>Crystalline rocks</b>
Matrix permeability	$1 \times 10^{-15} \text{ m}^2$	$9.97 \times 10^{-17} \text{ m}^2$	$1.21 \times 10^{-13} \text{ m}^2$
Fracture permeability	$4.93 \times 10^{-13} \text{ m}^2$	$9.97 \times 10^{-15} \text{ m}^2$	$1.21 \times 10^{-13} \text{ m}^2$
Matrix porosity	8%	0.4%	2%
Fracture porosity	11%	1%	2%
Reservoir pressure	468.75 bar	467.29 bar	474.7 bar
Density of the fluid	990 kg/m <sup>3</sup>	990 kg/m <sup>3</sup>	998 kg/m <sup>3</sup>
Specific heat capacity of the fluid	3,800 J/kgK	3,800 J/kgK	4,250 J/kgK
Fluid concentration	100 NaCl g/kg	100 NaCl g/kg	25 NaCl g/kg

The data related to matrix and fracture permeability, porosity, and other characteristics for sedimentary rocks were obtained through measurements of core samples, as well as for the volcanic rocks demo site. Specifically, the matrix permeability and porosity data for meta-sedimentary rocks were sourced from reference [323], where a group of authors compiled geological, hydrogeological, thermal, and paleoclimatic data. These data were then utilized to conduct hydro-geothermal modelling of temperature and heat flow. For the crystalline rocks demo site, data were gathered from references [324], [325]. In instances where precise values were unavailable, estimates were generated through correspondence with experts who are expertly familiar with the site. In determining reservoir pressure for each site, various sources of information were considered. This included using exact values, pressure gradients, or estimations derived from the geological context to approximate reservoir pressure at specific depths. The specific heat capacity of the fluid was estimated based on reference [326], which takes into account influencing factors such as fluid temperature and the concentration of sodium chloride. These factors were employed to derive the specific heat capacity values used in the analysis.

Additionally, for the sites to be comparable, the same well depth (both production and injection wells) is targeted.

The most important input parameters for all scenarios are shown in Table 6.27. Furthermore, to emphasize the significance of geological features in the analysis, several key parameters remain consistent across the scenarios. These parameters include the flow rate, reinjection temperature, yearly temperature drawdown, distance to the heating network, power plant availability, and maintenance frequency. By keeping these factors uniform, the analysis can effectively isolate and highlight the geological conditions as a primary factor influencing the outcomes.

Table 6.27. Main input parameters for each site

<b>Parameter</b>	<b>Sedimentary rocks</b>	<b>Meta-sedimentary rocks</b>	<b>Crystalline rocks</b>
Flow rate (total)	0.03 m <sup>3</sup> /s	0.03 m <sup>3</sup> /s	0.03 m <sup>3</sup> /s
Depth of production wells	5,000 m	5,000 m	5,000 m
Wellhead temperature	140°C	134.10°C	175°C
Reinjection temperature	70°C	70°C	70°C
Temperature drawdown	0.3 %	0.3 %	0.3 %
Distance to the power grid	3,000 m	3,000 m	3,000 m
Distance to the heating network	1,000 m	1,000 m	1,000 m
Power plant availability	90%	90%	90%
Month of maintenance	July	July	July

Financial parameters used in all scenarios are shown in Table 6.28. In heat production scenario only heat selling price parameter is used and in electricity generation scenario only electricity selling price parameter is used. Consequently, for the CHP scenario, both price parameters are used.

Table 6.28. Financial and economic parameters used in the financial analysis

<b>Parameter</b>	<b>All scenarios</b>
Discount rate (nominal)	7.06%
Inflation rate	1%
Effective tax rate	30%
Insurances (of installed costs)	1%
Heat selling price	45 €/MWh
Electricity selling price	100 €/MWh
Capacity based incentive	50% of production well and stimulation cost

The production and injection pumps were modelled as described in Section 6.7.1.3. The main input data for production and injection pumps are shown in Table 6.29.

Table 6.29. Input data for production and injection pumps used in all scenarios (and for all sites)

Parameter	Sedimentary rocks	Meta-sedimentary rocks	Crystalline rocks
ESP power	350 kW	350 kW	290 kW
ESP depth	550 m	550 m	470 m
ESP cost	1,223,704 €	1,223,704 €	1,093,136 €
Injection pump power	130 kW	130 kW	130 kW
Injection pump cost	424,000 €	424,000 €	424,000 €

### 6.7.2.3. Heat production scenario

In this scenario, the direct usage of geothermal energy was analysed and compared for the potential power plants in three mentioned different geological conditions. The heat demand is modelled for a greenhouse of approximately 3 ha with the monthly supply and return temperatures of heat demand, as shown in Figure 6.59 and required monthly mass flow rates, as shown in Figure 6.60.

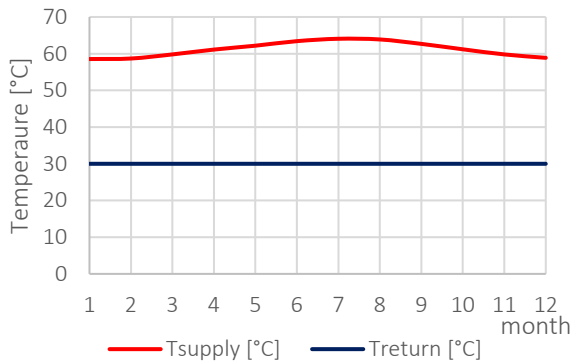

Figure 6.59. Supply and return temperatures of only heat production scenario (monthly values)

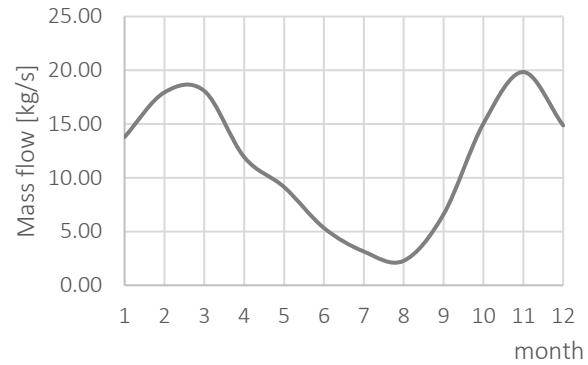

Figure 6.60. Mass flow of only heat production scenario (monthly values)

The capital costs for each of the site are presented in Table 6.30. These costs include production and injection well expenses as well as stimulation costs, and they are derived from reference [210]. The costs have been scaled in accordance with the respective well depths. It is assumed that the depth of the injection well matches that of the production well.

Leasing costs and additional expenses are uniform across all three sites, as the same land use surface area has been chosen. It's worth noting that the accuracy of the analysis could have been improved with actual data regarding leasing, drilling, stimulation, and similar activities in different geological settings.

Plant equipment costs depend on the installed capacity, and the 'six-tenth rule' has been utilized to estimate these costs for each demo site. These costs remain consistent for all three sites since the thermal power plants have the same installed heat capacity (as indicated in Table 6.30). The costs associated with pipes are also the same for each site, as the length of the piping remains constant in each case. When comparing specific capital costs, the

sedimentary demo site exhibits the highest value, alongside the meta-sedimentary demo site, both with costs of 13,675 €/kW. The crystalline rocks demo site features a slightly lower specific capital cost (13,620 €/kW), primarily due to the reduced production pump cost.

Table 6.30. Capital costs for heat production scenario for all three sites

<b>Parameter</b>	<b>All 3 sites</b>
Leasing	1,430,000 €
Additional cost	4,095,000 €
Production well cost	11,457,000 €
Injection well cost	10,309,000 €
Stimulation cost	2,000,000 €
Instrumentation	28,357 €
Heat exchanger	523,154 €
Heating network	700,916 €
Engineering	99,741 €
Substation	182,859 €
Piping and valves	192,638 €
Production pump	1,223,704 €
Injection pump	424,000 €
<b>TOTAL</b>	<b>33,090,369 €</b>
<b>Specific cost</b>	<b>13,675 €/kWh</b>

The individual operating and maintenance costs associated with each case are summarized in Table 6.31. These costs encompass both maintenance and labour expenses, with the former including wellfield maintenance and power plant maintenance costs. It's important to note that maintenance costs are uniform across all three demo sites due to the identical installed capacity. Labour costs, on the other hand, are contingent upon the installed capacity. Power plant operating costs are directly linked to the parasitic load, which is determined by the energy consumption of the production and injection pumps.

Table 6.31. Operational and maintenance cost for site in heat production scenario

<b>Parameter</b>	<b>Sedimentary rocks</b>	<b>Meta-sedimentary rocks</b>	<b>Crystalline rocks</b>
Maintenance cost	158,101 €/year	158,101 €/year	158,101 €/year
Labour	96,290 €/year	96,290 €/year	96,290 €/year
Power plant operating cost	0.02106 €/kWh	0.02106 €/kWh	0.01899 €/kWh

#### 6.7.2.3.1. Analysis of results

The results showing main output parameters for heat production scenario for all three sites are shown in Table 6.32. Given that the same plant power is installed across all sites, the entire heat demand can be satisfied at all sites. Additionally, with a power plant availability of 90% over the 30-year operational period, the amount of heat produced remains consistent across all four sites, as depicted in Figure 6.61.

However, the total avoided CO<sub>2</sub> emissions vary from site to site. This variation is contingent on the emission factors associated with each fossil fuel type and fossil fuel mix. These emission factors are specific to individual countries and serve as input values for the

analysis. As a result, the differences in avoided CO<sub>2</sub> emissions are influenced by the unique emission characteristics of each region's energy sources.

Table 6.32. Main output parameters for heat production scenario for all three sites

Parameter	Sedimentary rocks	Meta-sedimentary rocks	Crystalline rocks
Duration of operational period	30 years	30 years	30 years
Installed capacity - heat	2,630 kW	2,630 kW	2,630 kW
Total produced heat	342,418 MWh	342,418 MWh	342,418 MWh
Total unsatisfied heat demand	0 MWh	0 MWh	0 MWh
LCOH	313.43 €/MWh	313.43 €/MWh	306.54 €/MWh
Total avoided CO <sub>2</sub> emissions	81,634 tonnes	77,171 tonnes	99,527 tonnes

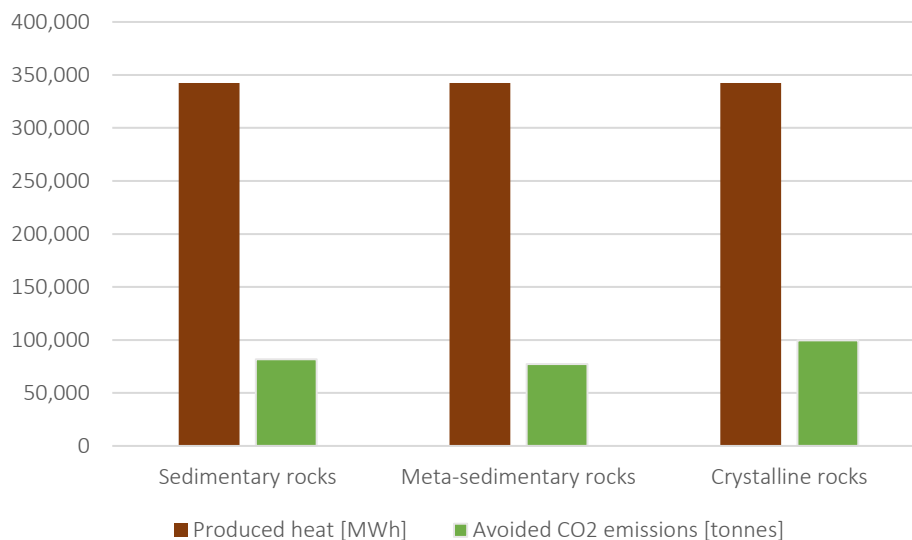

Figure 6.61. Total lifetime produced heat and avoided CO<sub>2</sub> emissions for each site

The results of Levelized Cost of Heat (LCOH) calculations for each analysed demo site are presented in Figure 17, alongside a comparison with the average cost of heat from natural gas [327]. Several observations can be made:

1. **Crystalline rocks site:** This site has a lowest LCOH due to the lower production pump costs (Table 6.29) which impacts the overall cost of heat production.
2. **Sedimentary and meta-sedimentary sites:** These sites exhibit the highest LCOH values. This is primarily a result of their geological characteristics and associated drilling and production costs, which contribute to a less competitive position in terms of heat production costs compared to natural gas.

In conclusion, the LCOH is lowest for the crystalline rocks site and highest for the sedimentary and meta-sedimentary demo sites, making them less economically competitive options for heat production in comparison to natural gas. The relative competitiveness of these projects may be influenced by factors such as fluctuations in gas prices and advancements in technology that could decrease costs.

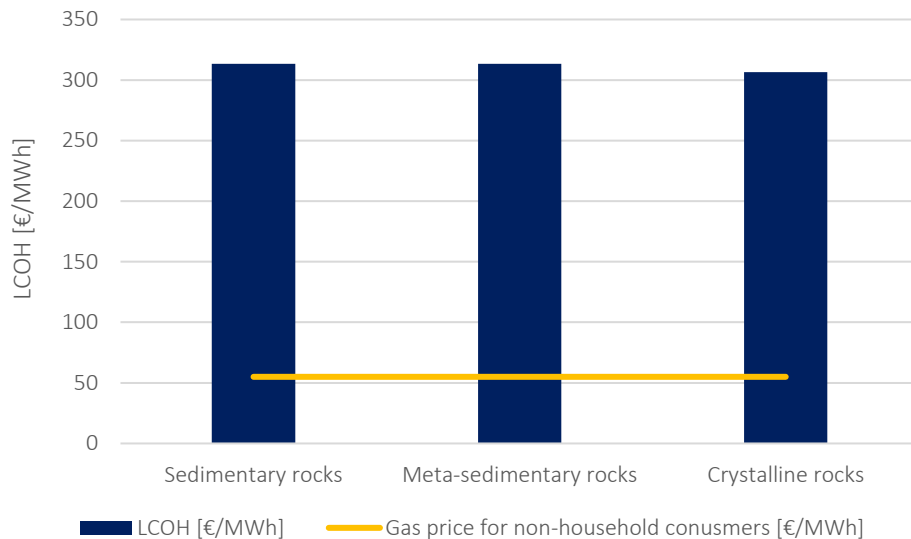

Figure 6.62. LCOH for each site in comparison with the average cost of heat from natural gas boilers for non-households

#### 6.7.2.4. Electricity generation scenario

In this scenario, the analysis focused on electricity production from various geological settings. To emphasize the role of geological features, key parameters including flow rate, reinjection temperature, yearly temperature drawdown, distance to the power grid, power plant availability, and the month of maintenance were kept consistent across all demo sites. This uniformity in parameters allowed the analysis to primarily isolate the impact of geological conditions on electricity production outcomes.

In this scenario, electricity production is achieved through an Organic Rankin Cycle (ORC) unit. The ORC unit is planned to be installed near the production well and is modelled using data from ENOGIA, as presented and described in detail in Section 6.3.3. The ORC unit is in the developed evaluation model designed based on a substantial number of discrete operational points obtained from their models. To calculate the ORC power plant production, the following parameters are required:

1. **Delta T ( $DT$ ):** This represents the difference between the inlet and outlet temperatures on the primary loop of the heat exchanger.
2.  **$\eta_{ORC}\{T_{inb}, DT\}$ :** ORC power plant efficiency, which is a function of the geothermal brine wellhead temperature and Delta T.
3.  **$F_{cool}\{T_{inb}, DT\}$ :** ORC power plant efficiency correction factor, which considers different temperatures of the ORC cycle coolant and is also a function of the geothermal brine wellhead temperature and Delta T.

The monthly average outside temperatures for each site are displayed in Figure 6.63 - Figure 6.65. The outside air temperature is significant because air serves as a coolant for the ORC unit, and it has a direct influence on the thermal efficiency of the ORC unit.

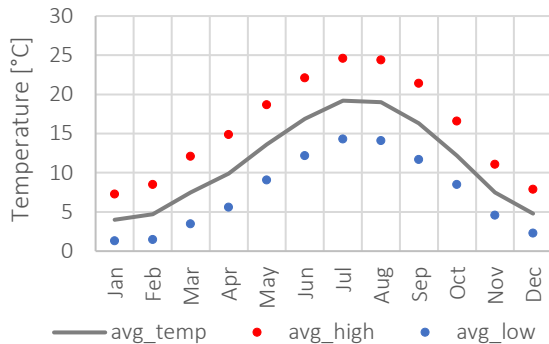

Figure 6.63. Monthly average outside air temperatures for sedimentary rocks site

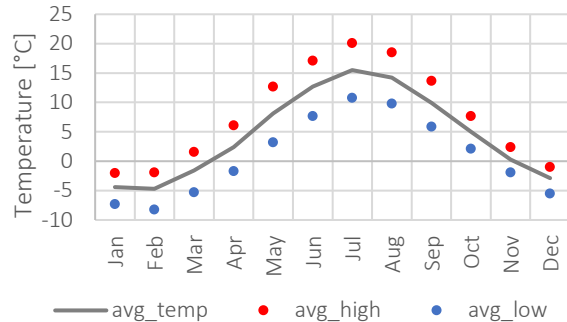

Figure 6.64. Monthly average outside air temperatures for meta-sedimentary rocks site

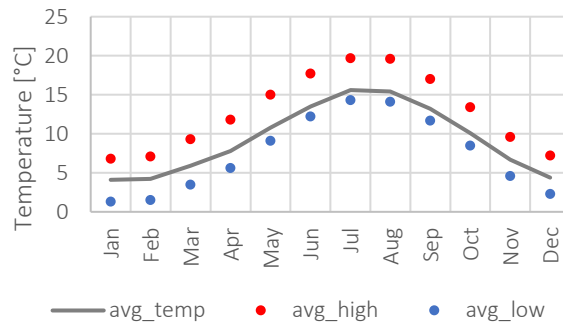

Figure 6.65. Monthly average outside air temperatures for crystalline rocks site

Capital investment costs for each demo site are presented in Table 6.33. Similar to the scenario for only heat production, the leasing and additional costs are uniform for all demo sites to standardize land use considerations. While using real data for leasing, drilling, stimulation, and other activities specific to different geological settings would have resulted in a more accurate analysis, standardized values were applied due to the unavailability of detailed data.

Plant equipment costs are determined based on the installed capacity, and the 'six-tenth rule' was utilized to assess these costs for each demo site. When comparing specific capital costs (cost per installed kilowatt, €/kW), the sedimentary site demonstrates the highest value (34,113 €/kW), followed by the meta-sedimentary rocks site (27,123 €/kW), with the crystalline site having the lowest specific capital cost (13,592 €/kW). These variations in capital costs are primarily attributed to differences in installed capacity among the demo sites.



Table 6.33. Capital cost for electricity generation scenario for each site

<b>Parameter</b>	<b>Sedimentary rocks</b>	<b>Meta-sedimentary rocks</b>	<b>Crystalline rocks</b>
Leasing	1,430,000 €	1,430,000 €	1,430,000 €
Additional cost	4,095,000 €	4,095,000 €	4,095,000 €
Production well cost	11,457,000 €	11,457,000 €	11,457,000 €
Injection well cost	10,309,000 €	10,309,000 €	10,309,000 €
Stimulation cost	2,000,000 €	2,000,000 €	2,000,000 €
ORC unit	677,371 €	777,284 €	1,173,791 €
Cold loop ancillaries	81,284 €	93,274 €	140,855 €
Dry cooler	135,474 €	155,456 €	234,758 €
Container housing	169,342 €	194,321 €	293,447 €
Start-up commissioning	50,802 €	58,296 €	88,034 €
Production pump	1,223,704 €	1,223,704 €	1,093,136 €
Injection pump	424,000 €	424,000 €	424,000 €
TOTAL	33,090,369 €	33,090,369 €	32,959,801 €
Specific cost	34,113 €/kWh	27,123 €/kWh	13,592 €/kWh

Operating and maintenance cost for each site are summarized in Table 6.34.

Table 6.34. Operational and maintenance cost for site in electricity generation scenario

<b>Parameter</b>	<b>Sedimentary rocks</b>	<b>Meta-sedimentary rocks</b>	<b>Crystalline rocks</b>
Power plant maintenance cost	214,245 €/year	245,850 €/year	389,785 €/year
Well field maintenance cost	200,000 €/year	200,000 €/year	200,000 €/year
Labour	142,830 €/year	163,900 €/year	259,857 €/year
Power plant operating cost	0.0258 €/kWh	0.0412 €/kWh	0.0224 €/kWh

#### 6.7.2.4.1. Analysis of results

The results for each demo site are summarized in Table 6.35. Across all modelled sites, the total parasitic load of the production facility can be fully covered by the energy production at each site, and the surplus net produced energy can be sold. As anticipated, the crystalline site exhibits the highest installed capacity, primarily due to its wellhead temperature being the highest (175°C) at a depth of 5,000 meters (Figure 6.66).

Figure 6.66 illustrates that the total avoided CO<sub>2</sub> emissions not only depend on the total amount of electricity produced but also on factors such as the replaced fossil fuel mix and emissions factors specific to each replaced fossil fuel. Both of these parameters are specific to the country in which the site is located. Consequently, the avoided CO<sub>2</sub> emissions output parameter should be interpreted with some caution, as it can vary based on the geographic location of the evaluated site.

Table 6.35. Main output parameters for each site for electricity generation scenario

<b>Parameter</b>	<b>Sedimentary rocks</b>	<b>Meta-sedimentary rocks</b>	<b>Crystalline rocks</b>
Installed electricity capacity	970 kW	1,220 kW	2,425 kW
Total produced electricity	174,003 MWh	199,522 MWh	394,956 MWh
LCOE	593.57 €/MWh	619.35 €/MWh	168.25 €/MWh
Total avoided CO <sub>2</sub> emissions	104,058 tonnes	95,913 tonnes	190,625 tonnes

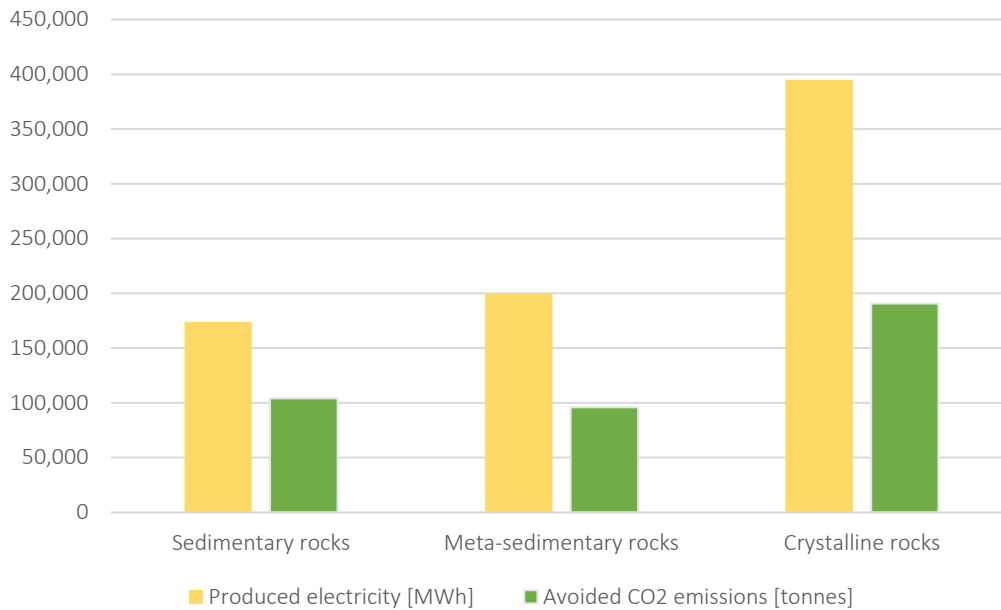

Figure 6.66. Total lifetime produced electricity and avoided CO<sub>2</sub> emissions for each site

The results of LCOE calculations for each analysed demo site are depicted in Figure 6.67. To provide context, the figure also includes the average electricity wholesale price in selected countries in the European Union (EU) from September 2020 to September 2021 (78.4 €/MWh) and the average electricity wholesale price in selected countries in the EU from September 2021 (142.03 €/MWh) [328], as much as average electricity wholesale price from January 2023 (126.59 €/MWh).

Observations from the figure reveal that all demo sites exhibit significantly higher LCOE values compared to these average wholesale electricity prices, except for the crystalline site. This discrepancy can be attributed to the fact that the crystalline site boasts the highest wellhead temperature, allowing for the highest production rates and, consequently, the highest revenues from selling produced electricity.

Specifically, while capital investment costs are similar for sedimentary, meta-sedimentary, and crystalline sites, the maximum possible electricity production for sedimentary and meta-sedimentary sites is substantially lower, as illustrated in Figure 6.66.

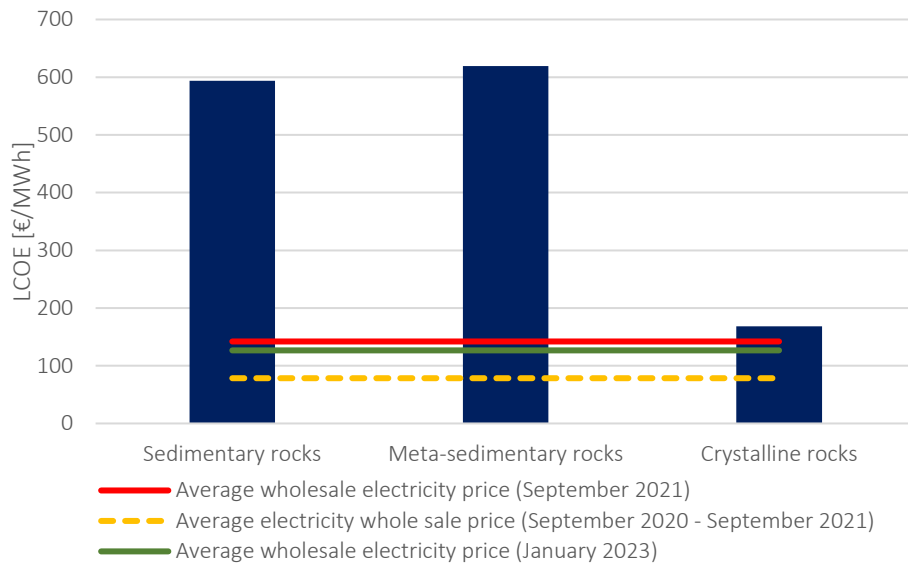

Figure 6.67. LCOE for each demo site in comparison with average wholesale electricity price in September 2021 and period of 12 months (September 2020 - September 2021).

#### 6.7.2.5. CHP scenario

In this scenario the combined heat and electricity production from different geological setting was analysed. In other words, heating production is upscaled with additional ORC unit for electricity production or electricity production is upscaled with exploiting the remaining heat from the electricity production. The depth of the injection well is the same as the depth of the production well. The main input parameters are shown in Table 6.27. Production and injection pump data are shown in Table 6.29.

The capital investment costs for each demo site are presented in Table 6.36. Similar to the only heat production scenario, the leasing and additional costs remain consistent across all demo sites, as it is assumed that the land use requirements are the same for all sites. While utilizing real data about leasing, drilling, stimulation, and related activities in different geological settings would have provided a more accurate analysis, the standardized values were employed due to the unavailability of such detailed data.

Plant equipment costs are calculated based on the installed capacity, applying the 'six-tenth rule' to evaluate these costs for each demo site. When expressing capital investment in €/kW, the sedimentary site has the highest capital cost (9,508 €/kW), followed by the meta-sedimentary site (9,450 €/kW), and the crystalline site (8,065 €/kW).

Operating and maintenance costs for each site in the CHP scenario are summarized in Table 6.37.

Table 6.36. Capital costs for each site for CHP scenario

<b>Parameter</b>	<b>Sedimentary rocks</b>	<b>Meta-sedimentary rocks</b>	<b>Crystalline rocks</b>
Leasing	1,430,000 €	1,430,000 €	1,430,000 €
Additional cost	4,095,000 €	4,095,000 €	4,095,000 €
Production well cost	11,457,000 €	11,457,000 €	11,457,000 €
Injection well cost	10,309,000 €	10,309,000 €	10,309,000 €
Stimulation cost	2,000,000 €	2,000,000 €	2,000,000 €
ORC unit	623,559 €	621,343 €	869,269 €
Cold loop ancillaries	74,827 €	74,561 €	104,312 €
Dry cooler	124,711 €	124,268 €	173,853 €
Container housing	155,889 €	155,335 €	217,317 €
Start-up commissioning	46,766 €	46,600 €	65,195 €
Instrumentation	17,679 €	17,679 €	17,679 €
Heat exchanger	326,164 €	326,164 €	326,164 €
Heating network	436,991 €	190,211 €	190,211 €
Engineering	62,184 €	62,184 €	62,184 €
Substation	114,005 €	114,005 €	114,005 €
Piping and valves	120,101 €	120,101 €	120,101 €
Production pump	1,223,704 €	1,223,704 €	1,093,136 €
Injection pump	424,000 €	424,000 €	424,000 €
TOTAL	33,041,580	32,791,155 €	33,068,426 €
Specific cost	9,508 €/kW	9,450 €/kW	8,065 €/kW

Table 6.37. Operational and maintenance cost for site in CHP scenario

<b>Parameter</b>	<b>Sedimentary rocks</b>	<b>Meta-sedimentary rocks</b>	<b>Crystalline rocks</b>
Power plant maintenance cost	215,974 €/year	215,806 €/year	234,596 €/year
Well field maintenance cost	200,000 €/year	200,000 €/year	200,000 €/year
Labour	102,756 €/year	102,756 €/year	102,756 €/year
Power plant operating cost	0.0135 €/kWh	0.0136 €/kWh	0.0109 €/kWh

#### 6.7.2.5.1. Analysis of results

The results of the analysis are summarized in Table 6.38, which indicates that all three cases are feasible in terms of technology, as they are able to satisfy the heat demand completely without any unsatisfied heat demand. At the sedimentary and meta-sedimentary sites, a parallel configuration mode is utilized with an ORC temperature difference of 60°C to meet the heat demand requirements. However, at the crystalline site, a series configuration mode is chosen, resulting in higher installed electricity capacity while still satisfying the heat demand.

Regarding electricity production, the series configuration in the crystalline rocks site leads to a higher installed ORC capacity and consequently higher electricity production quantities. It is followed by the sedimentary and meta-sedimentary rocks sites, which have similar installed power. The higher wellhead temperature at the crystalline site allows for a longer exploitation period and maintaining the temperature difference in the ORC. Moreover, in the series configuration, the fluid flow remains constant and is not divided based on the heat demand, which contributes to higher electricity production.

The avoided CO<sub>2</sub> emissions are directly dependent on the energy production, emission factor, and the share of each fossil fuel in the fossil fuel mix, which are country-specific

parameters. Interestingly, despite not having the highest energy production quantities, the meta-sedimentary site situated in Belgium, which has a significant share of coal in its heat and power production with a high emission factor for coal (2,090 g/kWh), results in the highest avoided CO<sub>2</sub> emissions.

For a visual comparison of produced energy and avoided CO<sub>2</sub> emissions, please refer to Figure 6.68.

Table 6.38. Main output parameters for each site for CHP scenario

Parameter	Sedimentary rocks	Meta-sedimentary rocks	Crystalline rocks
Installed capacity - heat	2,630 kW	2,630 kW	2,630 kW
Total produced heat	342,418 MWh	342,418 MWh	342,418 MWh
Total unsatisfied heat demand	0 MWh	0 MWh	0 MWh
Installed capacity - electricity	845 kW	840 kW	1,470 kW
Configuration	Parallel	Parallel	Series
Total produced electricity	182,927 MWh	177,988 MWh	248,887 MWh
LCOH	261.38 €/MWh	321.77 €/MWh	250.62 €/MWh
LCOE	287.87 €/MWh	403.2 €/MWh	292.79 €/MWh
Total avoided CO <sub>2</sub> emissions	255,543 tonnes	823,230 tonnes	245,872 tonnes

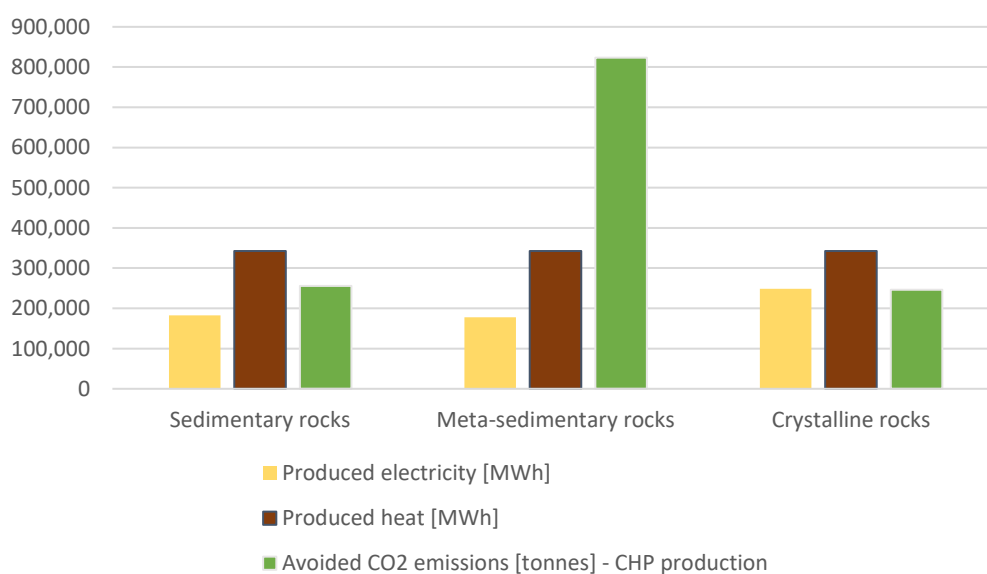

Figure 6.68. Total lifetime produced electricity, produced heat, and avoided CO<sub>2</sub> emissions for each site

The results of LCOE and LCOH calculations for each demo site are presented in Figure 6.69 and Figure 6.70. It is evident that all three sites all have LCOE values higher than the average wholesale electricity price, both from September 2021 and the period of 12 months from September 2020 to September 2021. This suggests that these scenarios are not competitive with other energy sources, such as natural gas, in terms of electricity production.

Among these sites, the meta-sedimentary site has the highest LCOE, primarily due to its lower installed capacity and one of the highest capital costs among the sites. It is followed by the crystalline rocks site and the sedimentary site.

In contrast, the crystalline site exhibits the lowest LCOH value, while meta-sedimentary showed the highest LCOH.

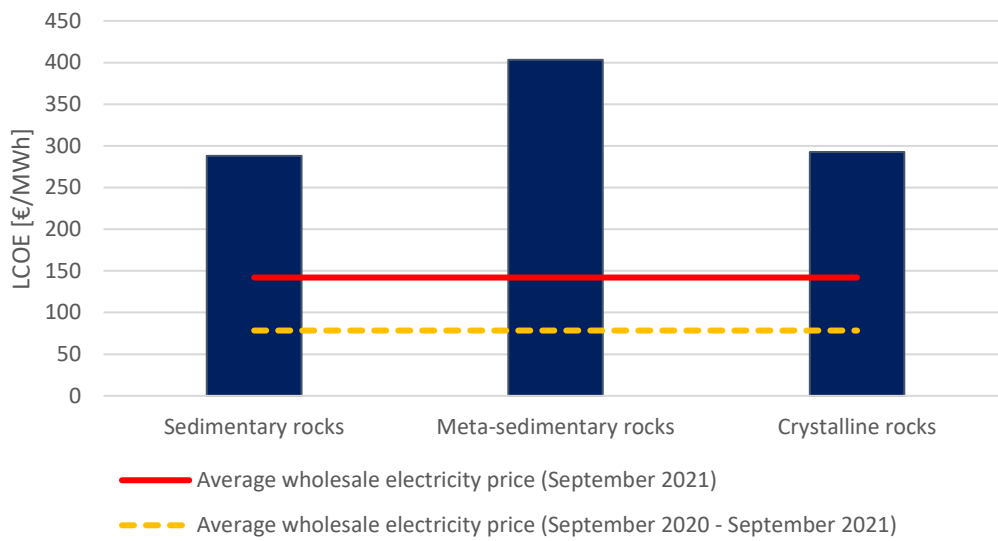

Figure 6.69. LCOE for each demo site in comparison with average wholesale electricity price in September 2021 and period of 12 months (September 2020 - September 2021)

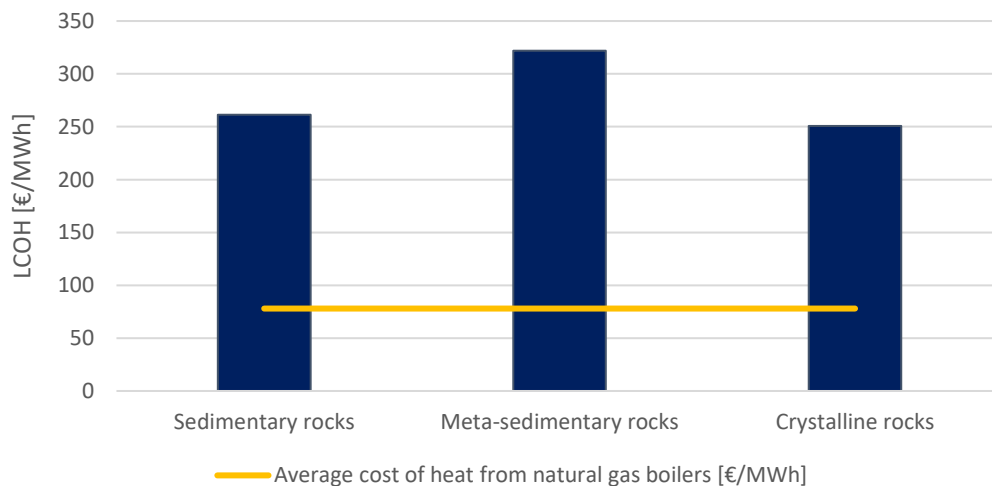

Figure 6.70. LCOH for each site in comparison with the average cost of heat from natural gas boilers for non-households

#### 6.7.2.6. MCDM analysis results

The results of the Multi-Criteria Decision-Making (MCDM) analysis are shown in Figure 6.71. The MCDM analysis was done for each scenario and for all geological sites.

The sedimentary rocks site received the highest grade, followed by the crystalline and meta-sedimentary rocks sites.

These results suggest that, when placing the most emphasis on geological criteria, followed by economic criteria, the most feasible heat production scenario is at the sedimentary site. This is likely due to the sedimentary site's high values of permeability and porosity, which are essential factors for efficient heat production.

When considering electricity generation scenario, as can be seen from the final results, the reservoir temperature, which is the highest at crystalline site did not have such big influence in final grade, because all other sites had also quite high temperatures. Meta-sedimentary rocks site did not only have the worst evaluation of permeability and porosity factors, but also because of country specific emission factors and fossil fuel mix, it had the lowest grade for the environment related avoided CO<sub>2</sub> emissions criteria.

In summary, the sedimentary site appears to be the most favourable for heat production and electricity generation when geological factors are prioritized, followed by the crystalline site. However, these rankings can vary depending on the specific criteria and weights assigned by decision-makers.

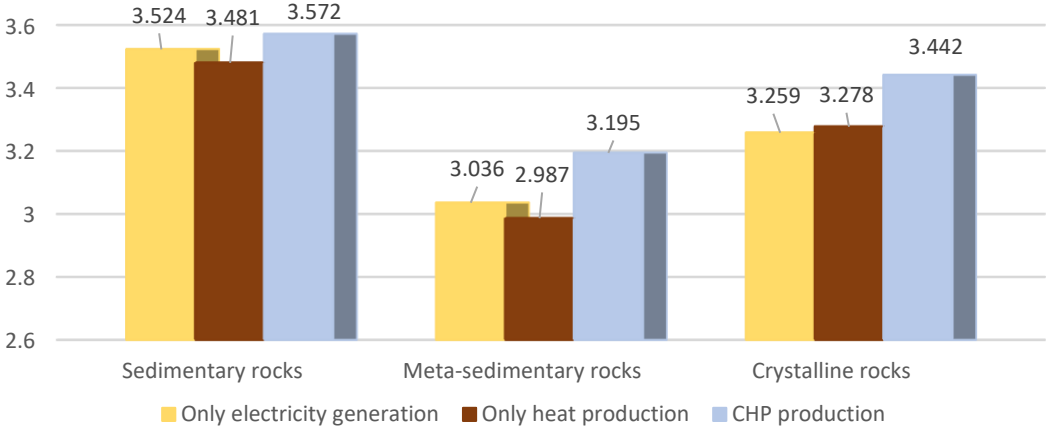

Figure 6.71. Final grades for each geological site and scenario obtained with the AHP-WSM MCDM analysis

If the results are analysed for each geological site (Figure 6.72), the best end-usage option for all three sites would be CHP. Second best ranked option for sedimentary and meta-sedimentary sites would be electricity generation, and for crystalline rocks the heat production. The least favourable option or ranked third for sedimentary and meta-sedimentary rocks would be heat production, and for crystalline rocks the electricity generation.

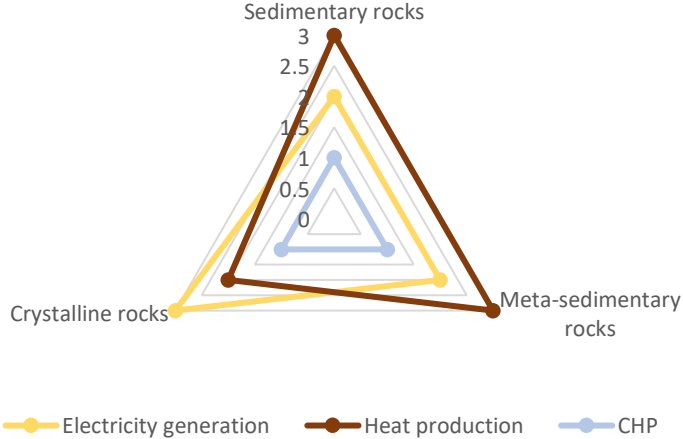

Figure 6.72. Ranking of the end usage options for each site





## CONCLUSIONS AND FUTURE DEVELOPMENT

GEOTHERMAL ENERGY is a worldwide available renewable energy source with the unique capability to provide consistent baseload power. Unlike many other renewables, it is not subject to intermittent generation due to weather conditions, and it doesn't rely on complex supply chains or transportation networks. While traditional hydrothermal systems are commercially exploitable with existing technology, huge geothermal energy potential can be tapped by Enhanced Geothermal Systems (EGS). EGS involves enhancing the productivity of low-permeability and low-porosity systems through various stimulation methods and advanced well configurations. This approach involves creating artificial fracture networks to facilitate the circulation of geothermal fluids in specific geological formations. In EGS, a continuous injection of water through an injection well is crucial to maintain the circulation of fluids within the created fracture network. These fluids heat up as they move through the fractures and are then brought to the surface through a production well(s) system. The extracted heat can be used directly for heating applications or to generate electricity through binary cycle Organic Rankine Cycle (ORC) power plants. In Combined Heat and Power (CHP) mode, it can be used for both electricity and heat production.

Geothermal projects, particularly Enhanced Geothermal Systems (EGS) projects, are inherently complex investments. These projects are deeply site-specific, and when evaluating their potential, whether as new greenfield projects or expansions of existing brownfield projects, sustainability must be a primary consideration. Sustainability, in the context of geothermal projects, encompasses three key dimensions: technological feasibility, environmental and social impact, and economic viability. As a result, a comprehensive and multidisciplinary approach is essential for assessing the sustainability of a geothermal project. This multidisciplinary approach must account for subsurface phenomena related to the reservoir, surface-level factors associated with various technologies (including extraction techniques, power plant configurations, and distribution systems), the specific heat and electricity requirements of end-users, and the environmental considerations closely intertwined with the project's ultimate beneficiaries. All of these dimensions significantly influence the economic feasibility and success of such projects.

Therefore, the decision-making process for sustainable energy projects is inherently complex due to the multidimensional nature of these projects and the intricate interplay of socio-environmental-economic systems. To navigate this complexity, the adoption of Multi-Criteria Decision-Making (MCDM) methods has gained prominence. These methods offer a structured approach to decision-making in the realm of sustainable energy.

EGS projects require decision-makers to account for a comprehensive and holistic set of factors, encompassing technical, economic, geological, societal, and environmental considerations. This complexity is further compounded by the involvement of diverse stakeholders, each with their own preferences, interests, and perspectives, all of which can significantly influence the decision-making process. These stakeholders may include various groups with distinct needs and desires, shaping the ultimate decision regarding EGS projects.

It's worth noting that geothermal energy projects, in general, face a challenge related to low public awareness regarding the benefits and possibilities of geothermal energy, whether in electricity generation or heating and cooling applications. This lack of awareness adds an additional layer of complexity to the decision-making process, as it necessitates addressing not only the technical and economic aspects but also the socio-environmental and geophysical factors.

Everything mentioned above was the motivation for developing an evaluation model that will be able to encompass all aspects of EGS project and enable standardized evaluation of such projects on a larger scale which is based on the developed MCDM methodology. The developed evaluation model and the proposed methodology are not intended to replace the need for in-depth expertise in the evaluation of Enhanced Geothermal Systems (EGS) project potential, which often involves more detailed and complex calculations and models. Instead, it serves as a valuable tool for offering a preliminary assessment and facilitating comparisons among different EGS sites. It does not provide a definitive pass or fail mark for a specific project but rather offers a starting point for initial evaluation and decision-making.

Moreover, this model is designed to enhance the understanding of EGS projects, particularly during the early stages of development. It can contribute to greater public awareness of such projects, which, in turn, may promote increased adoption of EGS within the market. Ultimately, this MCDM methodology aims to support more efficient decision-making processes and promote the sustainable development of EGS projects.

The thesis started with introduction to the field of geothermal energy in general as promising renewable energy source. The relevant definitions and information about the utilization of geothermal energy were presented as much as the thorough description of EGS

systems which enable exploitation of geothermal energy on wider geographical scale. Afterward, an extensive overview of existing models and software tools used for the assessment of Enhanced Geothermal Systems (EGS) projects, primarily focusing on their techno-economic evaluation aspects was provided. Based on the comparative analysis of these models and tools, the gaps and potential space for development of the evaluation model was detected.

Then, the focus was shifted to the multi-criteria decision-making (MCDM) methods because this is, as mentioned, one of the solutions when evaluating complex systems and problems. The MCDM methods were summarized and described by covering four main stages of MCDM process: 1) criteria identification and selection; 2) determination of criteria weights; 3) determination of the ranking of potential alternatives; 4) aggregation of the results of preference ranking order (if applicable). At each of these stages, various methods and techniques are available to facilitate the decision-making process. Mainly used methods are presented including a tabular comparative analysis of strengths and weaknesses of each mentioned method.

The decision-making process of evaluating investments in deep geothermal energy projects focusing on enhanced geothermal systems (EGSs) is a multi-criteria decision-making (MCDM) problem involving both quantitative and qualitative considerations and criteria. Therefore, the MCDM methodology was developed and thoroughly described in Chapter 5. The MCDM methodology consists of: i) method for standardized evaluation of influencing criteria based on the uniform grading of each identified and defined influencing criterion, ii) integrated MCDM methodology which consists of Analytic Hierarchy Process (AHP) method and VIKOR method used as weighting and ranking methods, respectively. The intended use of the proposed MCDM methodology is primarily for conducting a preliminary assessment of the technical and economic feasibility of EGS projects, with due consideration for their environmental and societal impacts. The most important contribution of the developed MCDM methodology is the confirmed ability of the designed method to be used not only by experts in the field of EGS projects but also by common users with little or no expert knowledge such as local community leaders etc. This was confirmed and showed with extensive analysis of the results of the survey conducted within a group of 38 experts with different backgrounds, experience and level of knowledge. This methodology offers the capability to assess and compare various options for harnessing geothermal energy for electricity and heat production, and it is adaptable for use in both brownfield and greenfield projects.

Lastly, a comprehensive evaluation model for enhanced geothermal systems (EGS) based on multi-criteria decision-making (MCDM) was presented. This model encompasses five primary aspects: geological setting, technology, economics, environment, and society. What sets this approach apart is its ability to facilitate comparisons, not only between different options for utilizing geothermal energy at a single production site but also among various geothermal production sites. Moreover, the model is developed as a MATLAB-based tool, offering a user-friendly graphical user interface (GUI) and a standalone application, which distinguishes it from most existing models and tools. Additionally, the integration of the MCDM methodology into this tool represents a novel feature that is not present in existing software packages and tools. The evaluation model was tested with case studies where the development of EGS projects was assessed in 1) one geological setting was assessed and different utilization options were compared (electricity generation, district heating, and CHP), and 2) different geological conditions (sedimentary, crystalline, and meta-sedimentary rocks) where different utilization options were also compared.

Certainly, the methods proposed in this thesis offer room for further enhancement and adaptation to suit various applications. For instance, the method used for standardized evaluation of criteria can be refined by employing different distribution patterns instead of the uniform distribution utilized in this version. Additionally, the AHP and VIKOR methods could be extended to be performed under a fuzzy environment, allowing for a more precise representation of uncertainty in human preferences. As for the evaluation model, its modularity provides flexibility for future development. Different functional modules can be expanded or streamlined to include varying levels of detail compared to the current version. Moreover, the model could be evolved to incorporate optimization capabilities, making it a versatile tool that caters to both simulation and optimization preferences, depending on the user's needs and decision-making context.

## BIBLIOGRAPHY

- [1] R. Dipippo, *Geothermal Power Generation. Developments and Innovation*, 1st ed. Woodhead Publishing, 2016.
- [2] P. Olasolo, M. C. Juárez, M. P. Morales, S. Damico, and I. A. Liarte, “Enhanced geothermal systems (EGS): A review,” *Renew. Sustain. Energy Rev.*, vol. 56, pp. 133–144, 2016.
- [3] S. M. Lu, “A global review of enhanced geothermal system (EGS),” *Renew. Sustain. Energy Rev.*, vol. 81, no. June, pp. 2902–2921, 2018.
- [4] G. W. Hutterer, C. Rica, and E. Salvador, “Geothermal Power Generation in the World 2015-2020 Update Report,” in *Proceedings World Geothermal Congress 2020*, 2020, pp. 1–17.
- [5] G. Pasaoglu, N. P. Garcia, and G. Zubi, “A multi-criteria and multi-expert decision aid approach to evaluate the future Turkish power plant portfolio,” *Energy Policy*, vol. 119, no. January, pp. 654–665, 2018.
- [6] H. C. Lee and C. Ter Chang, “Comparative analysis of MCDM methods for ranking renewable energy sources in Taiwan,” *Renew. Sustain. Energy Rev.*, vol. 92, pp. 883–896, 2018.
- [7] Y. Zhang, Y. Zhang, H. Yu, J. Li, Y. Xie, and Z. Lei, “Geothermal resource potential assessment of Fujian Province, China, based on geographic information system (GIS) - supported models,” *Renew. Energy*, vol. 153, pp. 564–579, 2020.
- [8] E. Trumpy *et al.*, “Geothermal potential assessment for a low carbon strategy: A new systematic approach applied in southern Italy,” *Energy*, vol. 103, pp. 167–181, 2016.
- [9] F. Meng, X. Liang, C. Xiao, and G. Wang, “Geothermal resource potential assessment utilizing GIS - based multi criteria decision analysis method,” *Geothermics*, vol. 89, pp. 1–11, 2021.
- [10] M. Abdel Zaher, S. Elbarbary, A. El-Shahat, H. Mesbah, and A. Embaby, “Geothermal resources in Egypt integrated with GIS-based analysis,” *J. Volcanol. Geotherm. Res.*, vol. 365, pp. 1–12, 2018.
- [11] M. Yalcin and F. Kilic Gul, “A GIS-based multi criteria decision analysis approach for exploring geothermal resources: Akarcay basin (Afyonkarahisar),” *Geothermics*, vol. 67, pp. 18–28, 2017.
- [12] M. Macharia, N. L. Commission, C. N. Mundia, and D. N. Kuria, “A Gis-Based Approach for Exploring Geothermal Resources Along Part of the Kenyan Rift,” *J. Appl. Sci. Eng. Technol. Dev.*, vol. 3, no. 1, pp. 1–34, 2018.
- [13] A. Aghahosseini and C. Breyer, “From hot rock to useful energy: A global estimate of enhanced geothermal systems potential,” *Appl. Energy*, vol. 279, pp. 1–19, 2020.
- [14] J. Limberger *et al.*, “Assessing the prospective resource base for enhanced geothermal systems in Europe,” *Geotherm. Energy Sci.*, vol. 2, no. 1, pp. 55–71, 2014.
- [15] C. R. Chamorro, J. L. García-Cuesta, M. E. Mondéjar, and A. Pérez-Madrado, “Enhanced geothermal systems in Europe: An estimation and comparison of the technical and sustainable potentials,” *Energy*, vol. 65, pp. 250–263, 2014.
- [16] G. Coro and E. Trumpy, “Predicting geographical suitability of geothermal power plants,” *J. Clean. Prod.*, vol. 267, p. 121874, 2020.
- [17] Z. He, Y. Zhang, J. Feng, Q. Ding, and P. Li, “An EGS Site Evaluation Method for Geothermal Resources Based on Geology, Engineering and Economic Considerations,” in *PROCEEDINGS, 43rd Workshop on Geothermal Reservoir Engineering*, 2018, pp. 1–9.
- [18] A. Mostafaeipour, S. J. H. Dehshiri, S. S. H. Dehshiri, M. Jahangiri, and K. Techato,

- “A thorough analysis of potential geothermal project locations in afghanistan,” *Sustain.*, vol. 12, no. 20, pp. 1–17, 2020.
- [19] A. Sowa-Watrak, I. Klosok-Bazan, M. Gono, and R. Gono, “The criteria for suitable location of geothermal power plant,” in *Proceedings of the 2017 18th International Scientific Conference on Electric Power Engineering, EPE 2017*, 2017.
- [20] T. A. K. Knoblauch and E. Trutnevyte, “Siting enhanced geothermal systems (EGS): Heat benefits versus induced seismicity risks from an investor and societal perspective,” *Energy*, 2018.
- [21] E. Soldo and C. Alimonti, “From an Oilfield to a Geothermal One : Use of a Selection Matrix to Choose Between Two Extraction Technologies,” in *World Geothermal Congress 2015*, 2015.
- [22] C. Alimonti, E. Soldo, D. Berardi, and D. Bocchetti, “A matrix method to select the more suitable extraction technology for the Campi Flegrei geothermal area (Italy),” in *European Geothermal Congress 2016*, 2016, pp. 19–24.
- [23] J. Al-Mahrouqi and G. Falcone, “An Expanded Matrix to Scope the Technical and Economic Feasibility of Waste Heat Recovery from Mature Hydrocarbon Fields,” in *PROCEEDINGS Geothermal Reservoir Engineering Stanford University*, 2016, vol. 3, no. 3, pp. 1–16.
- [24] H. Wei, X. Liang, Y. Chai, C. Xiao, and M. Liu, “Evaluation of Geothermal Resource Development Potential Using an Improved Analytic Hierarchy Process Method,” *SSRN Electron. J.*, 2021.
- [25] H. Singh, G. Falcone, A. Volle, and L. Guillon, “Harnessing geothermal energy from mature onshore oil fields, The Wytych Farm case study,” *Workshop on Geothermal Reservoir Engineering*. p. 17, 2017.
- [26] S. Frick, M. Kaltschmitt, and G. Schröder, “Life cycle assessment of geothermal binary power plants using enhanced low-temperature reservoirs,” *Energy*, vol. 35, no. 5, pp. 2281–2294, 2010.
- [27] A. Pratiwi, G. Ravier, and A. Genter, “Life-cycle climate-change impact assessment of enhanced geothermal system plants in the Upper Rhine Valley,” *Geothermics*, vol. 75, pp. 26–39, 2018.
- [28] A. Daniilidis, B. Alpsy, and R. Herber, “Impact of technical and economic uncertainties on the economic performance of a deep geothermal heat system,” *Renew. Energy*, vol. 114, pp. 805–816, 2017.
- [29] E. Santoyo-Castelazo and A. Azapagic, “Sustainability assessment of energy systems: Integrating environmental, economic and social aspects,” *J. Clean. Prod.*, vol. 80, no. 2014, pp. 119–138, 2014.
- [30] M. Borzoni, F. Rizzi, and M. Frey, “Geothermal power in Italy : A social multi-criteria evaluation,” *Renew. Energy*, vol. 69, pp. 60–73, 2014.
- [31] S. Eyerer, C. Schiffler, S. Hofbauer, W. Bauer, C. Wieland, and H. Spliethoff, “Combined heat and power from hydrothermal geothermal resources in Germany: An assessment of the potential,” *Renew. Sustain. Energy Rev.*, vol. 120, 2020.
- [32] International Energy Agency (IEA), “Renewable Energy Market Update,” 2022.
- [33] International Renewable Energy Agency (IRENA), “Global Geothermal Market and Technology Assessment,” 2023.
- [34] I. Stober and K. Bucher, *Geothermal Energy: From Theoretical Models to Exploration and Development*. Springer, 2013.
- [35] J. Lund, “Characteristics, development and utilization of geothermal resources,” *Proc. ISES World Congr. 2007 (Vol. I – Vol. V)*, 2007.
- [36] C. F. Williams, “Evaluating the volume method in the assessment of identified geothermal resources,” *Trans. - Geotherm. Resour. Counc.*, vol. 38, pp. 967–974, 2014.

- [37] G. Axelsson, “Nature and assessment of geothermal resources,” *SDG Short Course I Sustain. Environ. Manag. Geotherm. Resour. Util. Role Geotherm. Combat. Clim. Chang.*, pp. 1–23, 2016.
- [38] G. Falcone, A. Gnoni, B. Harrison, and C. Alimonti, “Classification and Reporting Requirements for Geothermal Resources,” *Eur. Geotherm. Congr. 2013*, vol. 1, no. June, p. 9, 2013.
- [39] V. Sen and A. Settari, “Simulation of permeability and geomechanical anisotropy in fractured reservoirs,” *Lead. Edge*, vol. 26, no. 9, pp. 1128–1133, 2007.
- [40] L. Mi *et al.*, “A utility discrete fracture network model for field-scale simulation of naturally fractured shale reservoirs,” *Soc. Pet. Eng. - SPE Argentina Explor. Prod. Unconv. Resour. Symp.*, no. June, 2016.
- [41] J. Unwin, “The oldest geothermal plant in the world,” *Power Technology*, 2019. [Online]. Available: [www.power-technology.com/features/oldest-geothermal-plant-larderello/?cf-view](http://www.power-technology.com/features/oldest-geothermal-plant-larderello/?cf-view). [Accessed: 20-Oct-2022].
- [42] “Geothermal Energy in Bulgaria.” [Online]. Available: <https://www.bage.bg/geothermal-bulgaria>.
- [43] M. Gehringer and V. Loksha, “Geothermal Handbook : Planning and Financing Power Generation,” 2012.
- [44] J. W. Lund and A. N. Toth, “Direct utilization of geothermal energy 2020 worldwide review,” *Geothermics*, vol. 90, no. July, 2021.
- [45] A. Sircar, K. Yadav, and S. Sahajpal, “Overview on Direct Applications of Geothermal Energy,” *Int. Adv. Res. J. Sci. Eng. Technol. ISO*, vol. 3297, no. 9, 2007.
- [46] M. Mburu, “Geothermal Energy Utilisation,” *Explor. Geotherm. Resour.*, pp. 1–11, 2009.
- [47] R. DiPippo, *Geothermal power plants: Principles, Applications, Case Studies and Environmental Impact*, 4th ed. Oxford, UK: Butterworth-Heinemann (Elsevier), 2016.
- [48] S. Van Erdeweghe, J. Van Bael, B. Laenen, and D. William, “Comparison of series/parallel configuration for a low-T geothermal CHP plant, coupled to thermal networks,” *Renew. Energy*, vol. 111, pp. 494–505, 2017.
- [49] S. Hirschberg, S. Wiemer, and P. Burgher, *Energy from the Earth: Deep Geothermal as a Resource*. Zürich: vdf Hochschulverlag AG an der ETH Zürich, 2015.
- [50] L. Rybach, “The Future of Geothermal Energy” and Its Challenges,” *World Geotherm. Congr.*, no. April, pp. 1–4, 2010.
- [51] G. R. Beardsmore, L. Rybach, D. Blackwell, and C. Baron, “A protocol for estimating and mapping global EGS potential,” *Trans. - Geotherm. Resour. Counc.*, vol. 34 1, no. October 2010, pp. 271–282, 2010.
- [52] P. Heidinger, “Integral modeling and financial impact of the geothermal situation and power plant at Soultz-sous-Forêts,” *Comptes Rendus - Geosci.*, vol. 342, no. 7–8, pp. 626–635, 2010.
- [53] E. Huenges and P. Ledru, *Geothermal Energy Systems: Exploration, Development, and Utilization*. Wiley-VCH Verlag GmbH & Co. KGaA, 2010.
- [54] T. Ma, P. Chen, and J. Zhao, “Overview on vertical and directional drilling technologies for the exploration and exploitation of deep petroleum resources,” *Geomech. Geophys. Geo-Energy Geo-Resources*, vol. 2, no. 4, pp. 365–395, 2016.
- [55] S. Pan, Y. Kong, C. Chen, Z. Pang, and J. Wang, “Optimization of the utilization of deep borehole heat exchangers,” *Geotherm. Energy*, vol. 8, no. 1, 2020.
- [56] K. Breede, K. Dzebisashvili, X. Liu, and G. Falcone, “A systematic review of enhanced (or engineered) geothermal systems: past, present and future,” *Geotherm. Energy*, vol. 1, no. 4, 2013.
- [57] T. Kölbel and A. Genter, “Enhanced Geothermal Systems: The Soultz- sous- Forêts

- Project,” in *Towards 100% Renewable Energy*, no. February, 2017, pp. 243–248.
- [58] S. M. Lu, “A global review of enhanced geothermal system (EGS),” *Renew. Sustain. Energy Rev.*, vol. 81, pp. 2902–2921, 2018.
- [59] P. Olasolo, M. C. Juárez, J. Olasolo, M. P. Morales, and D. Valdani, “Economic analysis of Enhanced Geothermal Systems (EGS). A review of software packages for estimating and simulating costs,” *Appl. Therm. Eng.*, vol. 104, pp. 647–658, 2016.
- [60] J. W. Tester, B. J. Anderson, A. S. Batchelor, D. D. Blackwell, and R. DiPippo, “The Future of Geothermal Energy - Impact of Enhanced Geothermal Systems (EGS) on the United States in the 21st Century,” Massachusetts, USA, 2006.
- [61] Australian Geothermal Energy Group Geothermal Code Committee, “Geothermal Lexicon For Resources and Reserves Definition and Reporting,” *Geotherm. Energy*, no. August, pp. 1–105, 2008.
- [62] C. F. Williams, M. J. Reed, and A. F. Anderson, “Updating the Classification of Geothermal Resources,” *Proceedings, Thirty-Sixth Work. Geotherm. Reserv. Eng. Stanford Univ. Stanford, California, January 31 - Febr. 2, 2011*, p. SGP-TR-191, 2011.
- [63] I. Stober, T. Fritzer, K. Obst, and R. Schulz, “Tiefe Geothermie: Nutzungsmöglichkeiten in Deutschland,” 2010.
- [64] S. Y. Pan, M. Gao, K. J. Shah, J. Zheng, S. L. Pei, and P. C. Chiang, “Establishment of enhanced geothermal energy utilization plans: Barriers and strategies,” *Renew. Energy*, vol. 132, pp. 19–32, 2019.
- [65] J. W. Tester, G. E. Morris, R. G. Cummings, and R. L. Bivins, “Electricity From Hot Dry Rock Geothermal Energy: Technical and Economic Issues.,” *Geotherm Energy*, vol. 7, no. 4, pp. 16–41, 1979.
- [66] J. W. Tester and H. Herzog, “Economic Predictions for Heat Mining: A review and Analysis of Hot Dry Rock (HDR),” Massachusetts, USA, 1990.
- [67] J. W. Tester and H. J. Herzog, “The Economics of Heat Mining An analysis of Design Options and Performance Requirements of Hot Dry Rock (HDR) Geothermal Power Systems,” in *Sixteenth Workshop on Geothermal Reservoir Engineering*, 1991, no. 1982, pp. 35–51.
- [68] P. Heidinger, J. Dornstädter, and A. Fabritius, “HDR economic modelling: HDRec software,” *Geothermics*, vol. 35, no. 5–6, pp. 683–710, 2006.
- [69] O. I. Kitsou, H. J. Herzog, and J. W. Tester, “Economic Modeling of HDR Enhanced Geothermal Systems,” in *Proceedings World Geothermal Congress 2000*, 2000, pp. 3779–3784.
- [70] G. Mines, “Geothermal Electricity Technologies Evaluation Model - DOE Tool for Assessing Impact of Research on Power Generation Costs,” in *Thirty-Third Workshop on Geothermal Reservoir Engineering*, 2008.
- [71] T. S. Lowry, E. Kalinina, T. Hadgu, K. A. Klise, and L. A. Malczynski, “Economic Valuation of Directional Wells for EGS Heat Extraction,” in *Thirty-Ninth Workshop on Geothermal Reservoir Engineering*, 2014, pp. 1–11.
- [72] J. W. T. Beckers, Koenraad F.; Maciej Z. Lukawski; Timothy J. Reber, Brian J. Anderson; Michal C. Moore, “Introducing Geophires V1.0: Software Package for Estimating Levelized Cost of Electricity and/or Heat From Enhanced Geothermal Systems,” in *Thirty-Eighth Workshop on Geothermal Reservoir Engineering*, 2013, p. 8.
- [73] K. F. Beckers *et al.*, “Levelized costs of electricity and direct-use heat from Enhanced Geothermal Systems,” *J. Renew. Sustain. Energy*, vol. 6, 2014.
- [74] J. and R. Tester T. and Beckers, K. and Lukawski, M. and Camp, E. and Aguirre, G., “Integrating Geothermal Energy Use into Re-building American Infrastructure,” in *Proceedings World Geothermal Congress 2015*, 2015, no. April.



- [75] T. J. Reber, K. F. Beckers, and J. W. Tester, “The transformative potential of geothermal heating in the U.S. energy market: A regional study of New York and Pennsylvania,” *Energy Policy*, vol. 70, pp. 30–44, 2014.
- [76] K. F. Beckers and K. McCabe, “Introducing GEOPHIRES v2.0: updated geothermal techno-economic simulation tool,” in *PROCEEDINGS, 43rd Workshop on Geothermal Reservoir Engineering*, 2018.
- [77] D. Montanari, L. Andr, R. Hopkirk, C. Calore, and E. Al., “ENGINE Coordination Action (Enhanced Geothermal Innovative Network for Europe) BEST PRACTICE HANDBOOK for the development of Unconventional Geothermal Resources with a focus on ENHANCED GEOTHERMAL SYSTEM,” 2008.
- [78] “ENGINE Decision Support System,” 2009. [Online]. Available: <http://engine.brgm.fr/DecisionSupportSystem.asp>. [Accessed: 07-Apr-2019].
- [79] N. Blair *et al.*, “System advisor model, sam 2014.1. 14: General description,” 2014.
- [80] “GEOELEC Software,” 2313. [Online]. Available: <http://www.geoelec.eu/software/>.
- [81] K. F. Beckers and K. McCabe, “GEOPHIRES v2.0: updated geothermal techno-economic simulation tool,” *Geotherm. Energy*, vol. 7, no. 1, 2019.
- [82] G. T. Office, “Geothermal Electricity Technology Evaluation Model,” 2016. [Online]. Available: <https://www.energy.gov/eere/geothermal/geothermal-electricity-technology-evaluation-model>.
- [83] ENGINE Coordination Action, “Performance Assessment Tool.” Utrecht, 2008.
- [84] “Develop Geothermal Electricity in Europe to have a renewable energy mix (GEOELEC),” *European Commission - Intelligent Energy Europe*, 2011. [Online]. Available: <http://www.geoelec.eu/wp-content/uploads/2011/09/GEOELEC-Project-Slides.pdf>. [Accessed: 20-Jul-2022].
- [85] “ENhanced Geothermal Innovative Network for Europe,” *European Union - 6th Research and Development framework*, 2006. [Online]. Available: <http://engine.brgm.fr/>. [Accessed: 16-Aug-2022].
- [86] T. U. S. D. of Energy, “Department of Energy.” [Online]. Available: <https://www.energy.gov/>. [Accessed: 17-Jul-2022].
- [87] The United States Department of Energy, “NREL - National Renewable Energy Laboratory.” [Online]. Available: <https://www.nrel.gov/>. [Accessed: 10-Sep-2022].
- [88] The United States Department of Energy National Laboratoy, “INL-Idaho National Laboratory.” [Online]. Available: <https://inl.gov/about-inl/>. [Accessed: 20-Sep-2022].
- [89] S. K. Sanyal, J. W. Morrow, S. J. Butler, and A. Robertson-Tait, “Cost of Electricity from Enhanced Geothermal Systems,” in *Thirty-Second Workshop on Geothermal Reservoir Engineering*, 2007, p. 11.
- [90] S. K. Sanyal, J. W. Morrow, S. J. Butler, and A. Robertson-Tait, “Is EGS commercially feasible?,” *Trans. - Geotherm. Resour. Counc.*, vol. 31, pp. 313–322, 2007.
- [91] A. Kumar *et al.*, “A review of multi criteria decision making (MCDM) towards sustainable renewable energy development,” *Renew. Sustain. Energy Rev.*, vol. 69, no. October 2016, pp. 596–609, 2017.
- [92] J. R. S. C. Mateo, *Multi-Criteria Analysis in the Renewable Energy Industry*. Springer-Verlag London, 2012.
- [93] H. Taherdoost and M. Madanchian, “Multi-Criteria Decision Making (MCDM) Methods and Concepts,” *Encyclopedia*, vol. 3, no. 1, pp. 77–87, 2023.
- [94] E. Triantaphyllou, B. Shu, S. N. Sanchez, and T. Ray, “Multi-Criteria Decision Making: An Operations Research Approach,” *Electronics*, vol. 15, no. August, pp. 175–186, 1998.
- [95] H. Polatidis, D. A. Haralambopoulos, G. Munda, and R. Vreeker, “Selecting an appropriate multi-criteria decision analysis technique for renewable energy planning,”

- Energy Sources, Part B Econ. Plan. Policy*, vol. 1, no. 2, pp. 181–193, 2006.
- [96] L. A. Greening and S. Bernow, “Design of coordinated energy and environmental policies: Use of multi-criteria decision-making,” *Energy Policy*, vol. 32, no. 6, pp. 721–735, 2004.
- [97] J. J. Wang, Y. Y. Jing, C. F. Zhang, and J. H. Zhao, “Review on multi-criteria decision analysis aid in sustainable energy decision-making,” *Renew. Sustain. Energy Rev.*, vol. 13, no. 9, pp. 2263–2278, 2009.
- [98] M. Pavan and R. Todeschini, “Multicriteria Decision-Making Methods,” *Compr. Chemom. Chem. Biochem. Data Anal. Second Ed. Four Vol. Set*, vol. 1, pp. 585–615, 2020.
- [99] G. Rowe and G. Wright, “Expert opinions in forecasting: The role of the Delphi Technique,” *Princ. Forecast.*, pp. 125–144, 2001.
- [100] W. Edwards and F. H. Barron, “SMARTS and SMARTER: Improved simple methods for multiattribute utility measurement,” *Organ. Behav. Hum. Decis. Process.*, vol. 60, no. 3, pp. 306–325, 1994.
- [101] T. L. Saaty, *The Analytic Hierarchy Process, Planning, Priority Setting, Resource Allocation*. New York: McGraw-Hill, 1980.
- [102] D. He, J. Xu, and X. Chen, “Information-theoretic-entropy based weight aggregation method in multiple-attribute group decision-making,” *Entropy*, vol. 18, no. 6, pp. 1–13, 2016.
- [103] V. Barichard, M. Ehrgott, X. Gandibleux, and V. T’Kindt, *Multiple Attribute Decision Making: Methods and Applications, A State-of-the-Art Survey*. New York: Springer-Verlag Berlin Heidelberg, 198AD.
- [104] N. Bagheri Moghaddam, M. Nasiri, and S. M. Mousavi, “An appropriate multiple criteria decision making method for solving electricity planning problems, addressing sustainability issue,” *Int. J. Environ. Sci. Technol.*, vol. 8, no. 3, pp. 605–620, 2011.
- [105] L. A. Zadeh, “Fuzzy Sets,” in *Fuzzy Sets, Fuzzy Logic, and Fuzzy Systems*, 1996, pp. 394–432.
- [106] B. Roy, “The Outranking Approach and the Foundations of ELECTRE Methods,” *Theory Decis.*, vol. 31, pp. 49–73, 1991.
- [107] R. Benayoun, B. Roy, and B. Sussman, “Electre: Une méthode pour guider le choix en présence de points de vue multiples,” 1966.
- [108] H. Polatidis, K. Haralambidou, and D. Haralambopoulos, “Multi-criteria decision analysis for geothermal energy: A comparison between the ELECTRE III and the PROMETHEE II methods,” *Energy Sources, Part B Econ. Plan. Policy*, vol. 10, no. 3, pp. 241–249, 2015.
- [109] G.-H. Tzeng and J.-J. Huang, *Multiple Attribute Decision Making: Methods and Applications*. CRC Press, Taylor & Francis, 2011.
- [110] S. Opricovic, “Multicriteria Optimization of Civil Engineering Systems,” 1998.
- [111] S. Opricovic and G. H. Tzeng, “Extended VIKOR method in comparison with outranking methods,” *Eur. J. Oper. Res.*, vol. 178, no. 2, pp. 514–529, 2007.
- [112] P. Korhonen, H. Moskowitz, and J. Wallenius, “Multiple criteria decision support - A review,” *Eur. J. Oper. Res.*, vol. 63, no. 3, pp. 361–375, 1992.
- [113] S. D. Pohekar and M. Ramachandran, “Application of multi-criteria decision making to sustainable energy planning - A review,” *Renew. Sustain. Energy Rev.*, vol. 8, no. 4, pp. 365–381, 2004.
- [114] M. Jovanović, N. Afgan, P. Radovanović, and V. Stevanović, “Sustainable development of the Belgrade energy system,” *Energy*, vol. 34, no. 5, pp. 532–539, 2009.
- [115] N. H. Afgan and M. G. Carvalho, “Multi-criteria assessment of new and renewable

- energy power plants,” *Energy*, vol. 27, no. 8, pp. 739–755, 2002.
- [116] N. H. Afgan and M. G. Carvalho, “Sustainability assessment of a hybrid energy system,” *Energy Policy*, vol. 36, no. 8, pp. 2903–2910, 2008.
- [117] B. A. Akash, R. Mamlook, and M. S. Mohsen, “Multi-criteria selection of electric power plants using analytical hierarchy process,” *Electr. Power Syst. Res.*, vol. 52, pp. 29–35, 1999.
- [118] A. I. Chatzimouratidis and P. A. Pilavachi, “Technological, economic and sustainability evaluation of power plants using the Analytic Hierarchy Process,” *Energy Policy*, vol. 37, no. 3, pp. 778–787, 2009.
- [119] E. Georgopoulou, D. Lalas, and L. Papagiannakis, “Multicriteria Decision Aid approach for energy planning problems: The case of renewable energy option,” *Eur. J. Oper. Res.*, vol. 103, no. 96, pp. 38–54, 1997.
- [120] M. Goumas and V. Lygerou, “An Extension of the PROMETHEE method for decision making in fuzzy environment: Ranking of alternative energy exploitation projects,” *Eur. J. Oper. Res.*, vol. 123, no. 3, pp. 606–613, 2000.
- [121] E. Georgopoulou, Y. Sarafidis, and D. Diakoulaki, “Design and implementation of a group DSS for sustaining renewable energies exploitation,” *Eur. J. Oper. Res.*, vol. 109, no. 2, pp. 483–500, 1998.
- [122] R. Ramanathan and L. S. Ganesh, “Energy resource allocation incorporating qualitative and quantitative criteria: An integrated model using goal programming and AHP,” *Socio-Economic Plan. Sci.*, vol. 29, no. 3, pp. 197–218, 1995.
- [123] B. F. Hobbs and P. M. Meier, “Multicriteria methods for resource planning: An experimental comparison,” *IEEE Trans. Power Syst.*, vol. 9, no. 4, pp. 1811–1817, 1994.
- [124] R. Ramanathan and L. S. Ganesh, “A multiobjective programming approach to energy resource allocation problems,” *Int. J. Energy Res.*, vol. 17, no. 2, pp. 105–119, 1993.
- [125] R. Chedid, T. Mezher, and C. Jarrouche, “A fuzzy programming approach to energy resource allocation,” *Int. J. Energy Res.*, vol. 23, no. 4, pp. 303–317, 1999.
- [126] M. M. Kablan, “Decision support for energy conservation promotion: An analytic hierarchy process approach,” *Energy Policy*, vol. 32, no. 10, pp. 1151–1158, 2004.
- [127] D. Diakoulaki, C. Zopounidis, G. Mavrotas, and M. Doumpos, “The use of a preference disaggregation method in energy analysis and policy making,” *Energy*, vol. 24, no. 2, pp. 157–166, 1999.
- [128] K. D. Patlitzianas, K. Ntotas, H. Doukas, and J. Psarras, “Assessing the renewable energy producers’ environment in EU accession member states,” *Energy Convers. Manag.*, vol. 48, no. 3, pp. 890–897, 2007.
- [129] E. Ilkog, “Indicators for assessment of rural electrification-An approach for the comparison of apples and pears,” *Energy Policy*, vol. 36, no. 7, pp. 2665–2673, 2008.
- [130] J. Hranic, S. Raos, E. Leoutre, and I. Rajšl, “Two-stage geothermal well clustering for oil-to-water conversion on mature oil fields,” *Geosci.*, vol. 11, no. 11, 2021.
- [131] L. S. Georgsson, “Geophysical methods used in geothermal exploration.” Ahuachapan and Santa Tecla, El Salvador, p. 16, 2009.
- [132] J. J. Wang, Y. Y. Jing, C. F. Zhang, G. H. Shi, and X. T. Zhang, “A fuzzy multi-criteria decision-making model for trigeneration system,” *Energy Policy*, vol. 36, no. 10, pp. 3823–3832, 2008.
- [133] A. P. Davis and E. E. Michaelides, “Geothermal power production from abandoned oil wells,” *Energy*, vol. 34, no. 7, pp. 866–872, 2009.
- [134] S. Xin, H. Liang, B. Hu, and K. Li, “Electrical power generation from low temperature co-produced geothermal resources at Huabei oilfield,” *Thirty-Seventh Work. Geotherm. Reserv. Eng. Stanford Univ. Stanford, California, January 30 – Febr. 1, 2012 SGP-TR-*

- 194, p. 6, 2012.
- [135] E. Dalmais, G. Ravier, V. Maurer, D. Fries, A. Genter, and B. Pandélis, “Environmental and Socio-Economic Impact of Deep Geothermal Energy, an Upper Rhine Graben Perspective,” in *Geothermal Energy - Challenges and Improvements*, 2022.
  - [136] S. J. Zarrouk and H. Moon, “Efficiency of geothermal power plants: A worldwide review,” *Geothermics*, vol. 51, pp. 142–153, 2014.
  - [137] M. Astolfi, M. C. Romano, P. Bombarda, and E. Macchi, “Binary ORC (organic Rankine cycles) power plants for the exploitation of medium-low temperature geothermal sources - Part A: Thermodynamic optimization,” *Energy*, vol. 66, pp. 423–434, 2014.
  - [138] M. Astolfi, M. C. Romano, P. Bombarda, and E. Macchi, “Binary ORC (Organic Rankine Cycles) power plants for the exploitation of medium-low temperature geothermal sources - Part B: Techno-economic optimization,” *Energy*, vol. 66, pp. 435–446, 2014.
  - [139] A. C. De Jesus, “Socio-economic impacts of Geothermal Development,” in *Pre-Congress Course on Environmental Aspects of Geothermal Development. IGA*, 1995.
  - [140] A. C. De Jesus, “Social Issues Raised and Measures Adopted in Philippine Geothermal Projects,” *Proc. World Geotherm. Congr.*, no. January 2005, pp. 24–29, 2005.
  - [141] M. Leucht, T. Kölbl, P. Laborgne, and N. Khomenko, “The Role of Societal Acceptance in Renewable Energy Innovations’ Breakthrough,” *Proc. World Geotherm. Congr.*, no. April, pp. 25–29, 2010.
  - [142] C. W. Chang, C. R. Wu, and H. C. Chen, “Using expert technology to select unstable slicing machine to control wafer slicing quality via fuzzy AHP,” *Expert Syst. Appl.*, vol. 34, no. 3, pp. 2210–2220, 2008.
  - [143] S. Raos, P. Ilak, I. Rajšl, T. Bilić, and G. Trullenque, “Multiple-Criteria Decision-Making for Assessing the Enhanced Geothermal Systems,” *Energies*, vol. 12, no. 9, p. 1597, Apr. 2019.
  - [144] S. Raos, J. Hranić, I. Rajšl, and K. Bär, “An extended methodology for multi-criteria decision-making process focused on enhanced geothermal systems,” *Energy Convers. Manag.*, vol. 258, no. September 2021, 2022.
  - [145] K. Breede, K. Dzebisashvili, and G. Falcone, “Overcoming challenges in the classification of deep geothermal potential,” *Geotherm. Energy Sci.*, vol. 3, no. 1, pp. 19–39, 2015.
  - [146] K. Bär *et al.*, “3D-modellierung der tiefeingeothermischen Potenziale von Hessen - Eingangsdaten und Potenzialausweisung,” *Zeitschrift der Dtsch. Gesellschaft für Geowissenschaften*, vol. 162, no. 4, pp. 371–388, 2011.
  - [147] M. Presho, S. Wo, and V. Ginting, “Calibrated dual porosity, dual permeability modeling of fractured reservoirs,” *J. Pet. Sci. Eng.*, vol. 11, pp. 326–337, 2011.
  - [148] I. S. Moeck, “Catalog of geothermal play types based on geologic controls,” *Renew. Sustain. Energy Rev.*, vol. 37, pp. 867–882, 2014.
  - [149] N. Rman *et al.*, “Geothermal sources and utilization practice in six countries along the southern part of the Pannonian basin,” *Environ. Earth Sci.*, vol. 79, no. 1, pp. 1–12, 2020.
  - [150] D. Montanari *et al.*, “Geothermal resources within carbonate reservoirs in western Sicily (Italy): A review,” *Earth-Science Rev.*, vol. 169, no. December 2016, pp. 180–201, 2017.
  - [151] S. K. Sanyal and S. J. Butler, “An Analysis of Power Generation Prospects from Enhanced Geothermal Systems,” in *Proceedings World Geothermal Congress 2005*,

- 2005, pp. 1–6.
- [152] M. P. Hochstein, “Classification and assessment of geothermal resources,” in *Small Geothermal Resources: A Guide to Development and Utilization*, M. H. Dickson and M. Fanelli, Eds. New York: UNITAR, 1990, pp. 31–57.
- [153] M. Rezaie and H. Aghajani, “A New Combinational Terminology for Geothermal Systems,” *Int. J. Geosci.*, vol. 4, pp. 43–48, 2013.
- [154] P. Muffler and R. Cataldi, “Methods for Regional Assessment of Geothermal Resources,” *Geothermics*, vol. 7, pp. 53–89, 1978.
- [155] Y. Benderitter and G. Cormy, “Possible approach to geothermal research and relative cost,” in *Small Geothermal Resources: A Guide to Development and Utilization*, M. H. Dickson and M. Fanelli, Eds. New York: UNITAR, 1990, pp. 59–69.
- [156] K. Nicholson, *Geothermal Fluids: Chemistry and Exploration Techniques*, 1st ed. Springer-Verlag Berlin Heidelberg, 1993.
- [157] G. Axelsson and E. Gunnlaugsson, “Geothermal Utilization, Management and Monitoring, in Long-Term Monitoring of High and Low-Enthalpy Fields under Exploitation,” in *World Geothermal Congress*, 2000, pp. 3–10.
- [158] S. K. Sanyal, “Classification of Geothermal Systems - A Possible Scheme,” in *13th Workshop on Geothermal Reservoir Engineering*, 2005, p. 8.
- [159] J. W. Tester, T. J. Reber, K. F. Beckers, and M. Z. Lukawski, “Deep geothermal energy for district heating: lessons learned from the U.S. and beyond,” in *Advanced District Heating and Cooling (DHC) Systems*, R. Wiltshire, Ed. Woodhead Publishing Series in Energy, 2016, pp. 75–98.
- [160] S. Popovska Vasilevska, “Drying of Agricultural Products with Geothermal Energy,” in *International Summer School on Direct Application of Geothermal Energy*, 2003, pp. 1–11.
- [161] K. Popovski and S. P. Vasilevska, “Prospects and problems for geothermal use in agriculture in Europe,” *Geometrics*, vol. 32, pp. 545–555, 2003.
- [162] I. J. Ronoh, “Geothermal Fluid for Industrial Use in the KenGen Green Energy Park , Kenya,” in *45th workshop on Geothermal Reservoir Engineering*, 2020, pp. 1–11.
- [163] M. Kaczmarczyk, B. Tomaszewska, and A. Operacz, “Sustainable Utilization of Low Enthalpy Geothermal,” *Energies*, vol. 13, no. 2495, 2020.
- [164] P. Ilak *et al.*, “Economic and environmental assessment of enhanced geothermal systems integration into energy systems: decision-making support tool for optimal usage of geothermal energy,” in *Mediterranean Conference on Power Generation, Transmission, Distribution and Energy Conversion (MEDPOWER 2018)*, 2018.
- [165] J. W. Lund and A. Chiasson, “Examples of combined heat and power plants using geothermal energy,” in *Transactions - Geothermal Resources Council*, 2007, vol. 31, no. April, pp. 225–230.
- [166] S. Van Erdeweghe, J. Van Bael, B. Laenen, and D. William, “Optimal combined heat-and-power plant for a low-temperature geothermal source,” *Energy*, vol. 150, pp. 396–409, 2018.
- [167] A. Sperber, I. Moeck, and W. Brandt, “Drilling into Geothermal Reservoirs,” in *Geothermal Energy Systems: Exploration, Development, and Utilization*, E. Huenges, Ed. Wiley-VCH Verlag GmbH & Co. KGaA, 2010, pp. 113–171.
- [168] J. Finger and D. Blankenship, “Handbook of Best Practices for Geothermal Drilling,” Albuquerque, New Mexico, 2010.
- [169] K. Denninger *et al.*, “Optimizing Geothermal Drilling: Oil and Gas Technology Transfer,” *Geotherm. Resour. Counc. Trans.*, vol. 39, pp. 171–180, 2015.
- [170] K. K. Bloomfield and P. T. Laney, “Estimating Well Costs For Enhanced Geothermal System Applications,” 2005.

- [171] Y. Polsky *et al.*, “Enhanced Geothermal Systems (EGS) Well Construction Technology Evaluation Report,” Albuquerque, New Mexico, California, 2008.
- [172] M. Z. Lukawski *et al.*, “Cost analysis of oil, gas, and geothermal well drilling,” *J. Pet. Sci. Eng.*, vol. 118, pp. 1–14, 2014.
- [173] G. L. Mines, “GETEM User Manual,” 2016.
- [174] H. Hole, “Directional Drilling of Geothermal Wells,” no. September. United Nations University, pp. 1–7, 2006.
- [175] U. Serpen and D. K. Basel, “Optimization of Geothermal Borehole Diameters,” in *Proceedings World Geothermal Congress 2015*, 2015, pp. 1–4.
- [176] V. C. Petrică, “Common Geothermal Well Design and a Case Study of the Low-temperature Geothermal Reservoir in Otopeni, Romania,” 2016.
- [177] K. R. Young, A. Badgett, K. McCabe, and P. F. Dobson, “GeoRePORT: Protocol Volume III: Technical Assessment Tool,” 2019.
- [178] S. D. C. Walsh, N. Garapati, A. M. M. Leal, and M. O. Saar, “Calculating thermophysical fluid properties during geothermal energy production with NESS and Reaktoro,” *Geothermics*, vol. 70, no. December 2016, pp. 146–154, 2017.
- [179] J. H. Lienhard, A. Antar, Mohamed, A. Bilton, J. Blanco, and G. Zaragoza, “Solar Desalination,” in *Annual Review of Heat Transfer*, 2012, pp. 277–347.
- [180] J. W. Lund and A. N. Toth, “Direct Utilization of Geothermal Energy 2020 Worldwide Review,” *Geothermics*, 2020.
- [181] R. Bertani, “Geothermal Power Generation in the World 2010-2014 Update Report,” in *Proceedings World Geothermal Congress 2015*, 2015, no. April, pp. 19–25.
- [182] R. Bertani, “Geothermal Power Generation in the World 2005 – 2010 Update Report,” in *Proceedings World Geothermal Congress 2010*, 2010, no. April 2010, pp. 25–29.
- [183] IRENA, “Power Generation Costs in 2017,” 2017.
- [184] T. Agemar, J. Weber, and R. Schulz, “Deep geothermal energy production in Germany,” *Energies*, vol. 7, no. 7, pp. 4397–4416, 2014.
- [185] J. Weber, B. Ganz, B. Sanner, and I. Moeck, “Geothermal Energy Use, Country Update for Belgium,” in *European Geothermal Congress 2016*, 2016, no. September, pp. 1–7.
- [186] Y. Gudmundsson, “Geothermal project timelines,” in *Proceedings 6th African Rift Geothermal Conference*, 2016, no. November, pp. 1–10.
- [187] J. R. San Cristóbal, “Multi-criteria decision-making in the selection of a renewable energy project in Spain: The Vikor method,” *Renew. Energy*, vol. 36, no. 2, pp. 498–502, 2011.
- [188] S. K. Lee, Y. J. Yoon, and J. W. Kim, “A study on making a long-term improvement in the national energy efficiency and GHG control plans by the AHP approach,” *Energy Policy*, vol. 35, no. 5, pp. 2862–2868, 2007.
- [189] M. R. Nava and T. U. Daim, “Evaluating alternative fuels in USA: A proposed forecasting framework using AHP and scenarios,” *Int. J. Automot. Technol. Manag.*, vol. 7, no. 4, pp. 289–313, 2007.
- [190] K. Baris and S. Kucukali, “Availability of renewable energy sources in Turkey: Current situation, potential, government policies and the EU perspective,” *Energy Policy*, vol. 42, pp. 377–391, 2012.
- [191] M. Amer and T. U. Daim, “Selection of renewable energy technologies for a developing county: A case of Pakistan,” *Energy Sustain. Dev.*, vol. 15, no. 4, pp. 420–435, 2011.
- [192] C. Kahraman, I. Kaya, and S. Cebi, “A comparative analysis for multiattribute selection among renewable energy alternatives using fuzzy axiomatic design and fuzzy analytic hierarchy process,” *Energy*, vol. 34, no. 10, pp. 1603–1616, 2009.
- [193] N. Yildirim, M. Toksoy, and G. Gokcen, “Piping network design of geothermal district

- heating systems: Case study for a university campus,” *Energy*, vol. 35, no. 8, pp. 3256–3262, 2010.
- [194] F. Zhou, “Research on heat transfer in geothermal wellbore and surroundings,” Technische Universität Berlin, 2013.
- [195] J. de León Vivar, “Deliverability of Geothermal Reservoirs,” Reykjavík, Iceland, 1988.
- [196] Z. Kamila, E. Kaya, and S. J. Zarrouk, “Reinjection in geothermal fields: An updated worldwide review 2020,” *Geothermics*, vol. 89, pp. 1–88, 2021.
- [197] E. Kaya, S. J. Zarrouk, and M. J. O’Sullivan, “Reinjection in geothermal fields: A review of worldwide experience,” *Renew. Sustain. Energy Rev.*, vol. 15, no. 1, pp. 47–68, 2011.
- [198] A. Rivera Diaz, E. Kaya, and S. Zarrouk, “Reinjection in geothermal fields, a worldwide review and analysis,” in *Proceedings World Geothermal Congress 2015*, 2015, pp. 19–25.
- [199] A. Rivera Diaz, E. Kaya, and S. J. Zarrouk, “Reinjection in geothermal fields - A worldwide review update,” *Renew. Sustain. Energy Rev.*, vol. 53, pp. 105–162, 2016.
- [200] M. D. Aliyu and H. P. Chen, “Sensitivity analysis of deep geothermal reservoir: Effect of reservoir parameters on production temperature,” *Energy*, vol. 129, pp. 101–113, 2017.
- [201] J. Chen and F. Jiang, “Designing multi-well layout for enhanced geothermal system to better exploit hot dry rock geothermal energy,” *Renew. Energy*, vol. 74, pp. 37–48, 2015.
- [202] W. L. Cheng, C. L. Wang, Y. Le Nian, B. B. Han, and J. Liu, “Analysis of influencing factors of heat extraction from enhanced geothermal systems considering water losses,” *Energy*, vol. 115, pp. 274–288, 2016.
- [203] T. Hadgu, E. Kalinina, and T. S. Lowry, “Modeling of heat extraction from variably fractured porous media in Enhanced Geothermal Systems,” *Geothermics*, vol. 61, pp. 75–85, 2016.
- [204] G. N. Wetang’ula, “Assessment of Geothermal Wastewater Disposal Effects,” 2004.
- [205] S. Werner, “European District Heating Price Series,” 2016.
- [206] A. Papadopoulos and A. Karagiannidis, “Application of the multi-criteria analysis method Electre III for the optimisation of decentralised energy systems,” *Omega*, vol. 36, no. 5, pp. 766–776, 2008.
- [207] D. A. Haralambopoulos and H. Polatidis, “Renewable energy projects: Structuring a multi-criteria group decision-making framework,” *Renew. Energy*, vol. 28, no. 6, pp. 961–973, 2003.
- [208] K. Alanne, A. Salo, A. Saari, and S. I. Gustafsson, “Multi-criteria evaluation of residential energy supply systems,” *Energy Build.*, vol. 39, no. 12, pp. 1218–1226, 2007.
- [209] D. Romanov and B. Leiss, “Analysis of Enhanced Geothermal System Development Scenarios for District Heating and Cooling of the Göttingen University Campus,” *Geosciences*, vol. 11, no. 8, p. 349, 2021.
- [210] H. C. Doukas, B. M. Andreas, and J. E. Psarras, “Multi-criteria decision aid for the formulation of sustainable technological energy priorities using linguistic variables,” *Eur. J. Oper. Res.*, vol. 182, no. 2, pp. 844–855, 2007.
- [211] P. A. Pilavachi, C. P. Rourke, S. Minett, and N. H. Afgan, “Multi-criteria evaluation for CHP system options,” *Energy Convers. Manag.*, vol. 47, no. 20, pp. 3519–3529, 2006.
- [212] J. J. Wang, Y.-Y. Jing, and C.-F. Zhang, “Weighting methodologies in multi-criteria evaluations of combined heat and power systems,” *Int. J. Energy Res.*, vol. 33, pp. 1023–1039, 2009.

- [213] E. Løken, A. Botterud, and A. T. Holen, "Use of the equivalent attribute technique in multi-criteria planning of local energy systems," *Eur. J. Oper. Res.*, vol. 197, no. 3, pp. 1075–1083, 2009.
- [214] J. Burton and K. Hubacek, "Is small beautiful? A multicriteria assessment of small-scale energy technology applications in local governments," *Energy Policy*, vol. 35, no. 12, pp. 6402–6412, 2007.
- [215] IRENA, "Renewable Power Generation Costs in 2019," Abu Dhabi, 2020.
- [216] IRENA, "RENEWABLE POWER GENERATION COSTS IN 2018," 2018.
- [217] C. Clauser and M. Ewert, "The renewables cost challenge: Levelized cost of geothermal electric energy compared to other sources of primary energy – Review and case study," *Renew. Sustain. Energy Rev.*, vol. 82, pp. 3683–3693, 2018.
- [218] IEA and NEA, "Projected Costs of Generating Electricity, 2015 Edition," 2015.
- [219] U.S. Department of Energy, "GEO Vision: arnessing the Heat Beneath Our Feet," 2019.
- [220] B. Goldstein *et al.*, "Geothermal Energy," in *IPCC Special Report on Renewable Energy Sources and Climate Change Mitigation*, Cambridge, United Kingdom and New York, NY, USA: Cambridge University Press, 2011, pp. 401–436.
- [221] (EGEC) European Geothermal Energy Council, "EGEC policy paper on 'Financing Geothermal Energy,'" 2013.
- [222] K. F. Beckers and K. R. Young, "Performance, Cost, and Financial Parameters of Geothermal District Heating Systems for Market Penetration Modeling under Various Scenarios," in *42nd Workshop on Geothermal Reservoir Engineering*, 2017, pp. 1–11.
- [223] P. A. Pilavachi, S. D. Stephanidis, V. A. Pappas, and N. H. Afgan, "Multi-criteria evaluation of hydrogen and natural gas fuelled power plant technologies," *Appl. Therm. Eng.*, vol. 29, no. 11–12, pp. 2228–2234, 2009.
- [224] O. Demirtas, "Evaluating the best renewable energy technology for sustainable energy planning," *Int. J. Energy Econ. Policy*, vol. 3, no. SPECIAL ISSUE, pp. 23–33, 2013.
- [225] F. Cavallaro and L. Ciruolo, "A multicriteria approach to evaluate wind energy plants on an Italian island," *Energy Policy*, vol. 33, no. 2, pp. 235–244, 2005.
- [226] J. J. Wang, Y. Y. Jing, C. F. Zhang, X. T. Zhang, and G. H. Shi, "Integrated evaluation of distributed triple-generation systems using improved grey incidence approach," *Energy*, vol. 33, no. 9, pp. 1427–1437, 2008.
- [227] R. Mamlook, B. A. Akash, and M. S. Mohsen, "A neuro-fuzzy program approach for evaluating electric power generation systems," *Energy*, vol. 26, no. 6, pp. 619–632, 2001.
- [228] M. Pehnt, "Dynamic life cycle assessment (LCA) of renewable energy technologies," *Renew. Energy*, vol. 31, no. 1, pp. 55–71, 2006.
- [229] A. V. H. Sola and C. M. D. M. Mota, "A multi-attribute decision model for portfolio selection aiming to replace technologies in industrial motor systems," *Energy Convers. Manag.*, vol. 57, pp. 97–106, 2012.
- [230] W. Short, D. Packey, and T. Holt, "A manual for the economic evaluation of energy efficiency and renewable energy technologies," *Renew. Energy*, vol. 95, no. March, pp. 73–81, 1995.
- [231] G. E. NET, "Financial Instruments and Funding of RD & D and Geothermal Projects Barriers and Opportunities," 2016.
- [232] B. Sigfusson and A. Uihlein, *2014 JRC Geothermal Energy Status Report*, no. January. 2015.
- [233] P. Dumas *et al.*, "Risk Mitigation and Insurance Schemes Adapted to Geothermal Market Maturity: The Right Scheme for my Market," in *European Geothermal Congress 2019*, 2019, no. June, pp. 1–8.



- [234] F. Cavallaro, *Assessment and simulation tools for sustainable energy systems: Theory and applications*, vol. 129. Springer, 2013.
- [235] S. V. Payera, “Understanding social acceptance of geothermal energy : Case study for Araucanía region , Chile,” *Geothermics*, vol. 72, no. October 2017, pp. 138–144, 2018.
- [236] S. Karytsas, O. Polyzou, D. Mendrinou, and C. Karytsas, “Towards social acceptance of geothermal energy power plants,” in *European Geothermal Congress 2019*, 2019, no. June.
- [237] K. Popovski, “Political and public acceptance of geothermal energy,” Reykjavík, Iceland, 2003.
- [238] P. Chavot, C. Heimlich, A. Masseran, Y. Serrano, J. Zoungrana, and C. Bodin, “Social shaping of deep geothermal projects in Alsace : politics , stakeholder attitudes and local democracy,” *Geotherm. Energy*, pp. 1–21, 2018.
- [239] A. Ibrohim, R. M. Prasetyo, and I. H. Rekinagara, “Understanding Social Acceptance of Geothermal Energy : A Case Study,” *IOP Conf. Ser. Earth Environ. Science*, vol. 254, 2019.
- [240] M. Bošnjaković, M. Stojkov, and M. Jurjević, “Environmental impact of geothermal power plants,” *Teh. Vjesn.*, vol. 26, no. 5, pp. 1515–1522, 2019.
- [241] T. B. Johansson, A. Patwardhan, N. Nakićenović, and L. Gomez-Echeverri, *Global Energy Assessment: Toward a Sustainable Future*. Cambridge University Press: Cambridge UK and New York, NY, USA and the International Institute for Applied Systems Analysis, Laxenburg, Austria, 2012.
- [242] T. Fridriksson, A. Mateos, P. Audinet, and Y. Orucu, “Greenhouse Gases from Geothermal Power Production,” *Greenh. Gases from Geotherm. Power Prod.*, 2016.
- [243] E. Huenges and S. Frick, “Costs of Co<sub>2</sub>-Mitigation by Deployment of Enhanced Geothermal Systems Plants,” *Proc. World Geotherm. Congr.*, no. April, pp. 25–29, 2010.
- [244] J. Bonafin, C. Pietra, A. Bonzanini, and P. Bombarda, “CO<sub>2</sub> emissions from geothermal power plants : evaluation of technical solutions for CO<sub>2</sub> reinjection,” *Eur. Geotherm. Congr. 2019*, no. June, pp. 11–14, 2019.
- [245] L. Gerber and F. Maréchal, “Environomic optimal configurations of geothermal energy conversion systems: Application to the future construction of Enhanced Geothermal Systems in Switzerland,” *Energy*, vol. 45, no. 1, pp. 908–923, 2012.
- [246] J. M. Semedi, L. Willemen, T. Nurlambang, and F. Van Der, “Developing a framework for assessing the impact of geothermal development phases on ecosystem services  
Developing a framework for assessing the impact of geothermal development phases on ecosystem services,” in *IOP Conference Series: Earth and Environmental Science*, 2017.
- [247] M. a Barrantes, U. E. N. Pysa, S. José, and C. Rica, “Geoenviromental Aspects of the Development of Las Pailas Geothermal Field , Costa Rica,” no. April, pp. 25–29, 2010.
- [248] ESMAP, “Drilling Down on Geothermal Potential,” *Drill. Down Geotherm. Potential*, 2012.
- [249] E. Meijaard, R. A. Dennis, B. K. Saputra, G. J. Draugelis, M. C. A. Qadir, and S. Garnier, “Rapid Environmental and Social Assessment of Geothermal Power Development in Conservation Forest of Indonesia,” *Proc. World Geotherm. Congr. 2020 Reykjavik, Iceland, April 26 – May 2, 2020*, no. August, pp. 1–12, 2019.
- [250] A. Zang *et al.*, “Analysis of induced seismicity in geothermal reservoirs - An overview,” *Geothermics*, vol. 52, no. 2014, pp. 6–21, 2014.
- [251] K. F. Evans, A. Zappone, T. Kraft, N. Deichmann, and F. Moia, “A survey of the induced seismic responses to fluid injection in geothermal and CO<sub>2</sub> reservoirs in Europe,” *Geothermics*, vol. 41, pp. 30–54, 2012.

- [252] C. Bauer *et al.*, *Energy from the Earth Deep Geothermal as a Resource for the Future?* 2015.
- [253] V. S. Gischig *et al.*, “Hydraulic stimulation and fluid circulation experiments in underground laboratories: Stepping up the scale towards engineered geothermal systems,” *Geomech. Energy Environ.*, p. 100175, 2020.
- [254] E. Majer, J. Nelson, A. Robertson-Tait, J. Savy, and I. Wong, “Protocol for Addressing Induced Seismicity Associated with Enhanced Geothermal Systems,” *Department of Energy (DoE)*. p. 52, 2011.
- [255] J. Schmittbuhl, O. Lengliné, F. Cornet, N. Cuenot, and A. Genter, “Induced seismicity in EGS reservoir: the creep route,” *Geotherm. Energy*, vol. 2, no. 1, pp. 1–13, 2014.
- [256] N. Cuenot, L. Dorbath, M. Frogneux, and N. Langet, “Microseismic Activity Induced Under Circulation Conditions at the EGS Project of Soultz-Sous-Forêts ( France ),” *Proc. World Geotherm. Congr.*, no. December 2005, pp. 25–29, 2010.
- [257] B. Field, B. Barton, R. Funnell, K. Higgs, and A. Nicol, “Managing potential interactions of subsurface resources,” *J. Power Energy*, vol. 232, no. 1, pp. 6–11, 2018.
- [258] S. Opricovic and G. H. Tzeng, “Compromise solution by MCDM methods: A comparative analysis of VIKOR and TOPSIS,” *Eur. J. Oper. Res.*, vol. 156, no. 2, pp. 445–455, 2004.
- [259] T. L. Saaty, *The analytical hierarchy process: Planning, priority setting, resource allocation*. London: McGraw-Hill, 1980.
- [260] T. L. Saaty, “An eigen value location model for prioritization and planning,” 1972.
- [261] T. L. Saaty, “A scaling method for priorities in hierarchical structures,” *J. Math. Psychol.*, vol. 15, no. 3, pp. 234–281, 1977.
- [262] L. L. Thurstone, “A law of comparative judgment,” *Psychol. Rev.*, vol. 34, no. 4, pp. 273–286, 1927.
- [263] J. R. I. Miller, “The assessment of worth: a systematic procedure and its experimental validation,” Massachusetts Institute of Technology (MIT), 1966.
- [264] S. Stevens, “On the psychophysical law,” *Psychol. Rev.*, vol. 64, pp. 153–181, 1957.
- [265] T. L. Saaty and L. Vargas, *Models, methods, concepts & applications of the analytic hierarchy process*, 2nd ed., vol. 175. New York: Springer, 2012.
- [266] E. H. Forman and S. I. Gass, “The Analytical Hierarchy Process - An Exposition,” *Jstor, Oper. Res.*, vol. 49, pp. 1–86, 1999.
- [267] T. L. Saaty, *Fundamentals of Decision Making and Priority Theory*. Pittsburgh, PA: RWS Publications, 1994.
- [268] T. L. Saaty, “Axiomatization of the Analytic Hierarchy Process.” pp. 91–108, 1985.
- [269] R. W. Saaty, “The analytic hierarchy process-what it is and how it is used,” *Math. Model.*, vol. 9, no. 3–5, pp. 161–176, 1987.
- [270] T. Saaty and K. Kułakowski, “Axioms of the Analytic Hierarchy Process (AHP) and its Generalization to Dependence and Feedback: The Analytic Network Process (ANP),” 2016.
- [271] V. Sangiorgio, G. Uva, and F. Fatiguso, “Optimized AHP to Overcome Limits in Weight Calculation: Building Performance Application,” *J. Constr. Eng. Manag.*, vol. 144, no. 2, pp. 1–14, 2018.
- [272] A. Ishizaka and A. Labib, “Review of the main developments in the analytic hierarchy process,” *Expert Syst. Appl.*, vol. 38, no. 11, pp. 14336–14345, 2011.
- [273] T. L. Saaty, K. P. Kearns, and E. Y. (Auth) Rodin, *Analytical Planning. The Organization of System*, 1st ed., vol. 7. Elsevier Ltd, Pergamon Press, 1985.
- [274] P. Harker and L. Vargas, “The theory of ratio scale estimation: Saaty’s analytic hierarchy process,” *Manage. Sci.*, vol. 33, pp. 1383–1403, 1987.
- [275] F. Lootsma, “Conflict resolution via pairwise comparison of concessions,” *Eur. J.*

- Oper. Res.*, vol. 40, pp. 109–116, 1989.
- [276] A. Ishizaka, D. Balkenborg, and T. Kaplan, “Influence of aggregation and measurement scale on ranking a compromise alternative in AHP,” *J. Oper. Reserch Soc.*, vol. 62, pp. 700–710, 2010.
- [277] F. Dodd and H. Donegan, “Comparison of prioritization techniques using interhierarchy mappings,” *J. Oper. Reserch Soc.*, vol. 46, no. 492–498, 1995.
- [278] D. Ma and X. Zheng, “9/9-9/1 Scale method of AHP,” in *Second intenrational symposium on AHP*, 1991, vol. 1, pp. 197–202.
- [279] A. Salo and R. Hamalainen, “On the measurement of preference in the analytic hierarchy process,” *J. Multi-Criteria Decis. Anal.*, vol. 6, pp. 309–319, 1997.
- [280] B. C. Kim, J. Kim, and J. Kim, “Evaluation model for investment in solar photovoltaic power generation using fuzzy analytic hierarchy process,” *Sustainability*, vol. 11, no. 10, pp. 1–23, 2019.
- [281] E. Heo, J. Kim, and K. J. Boo, “Analysis of the assessment factors for renewable energy dissemination program evaluation using fuzzy AHP,” *Renew. Sustain. Energy Rev.*, vol. 14, no. 8, pp. 2214–2220, 2010.
- [282] E. Heo, J. Kim, and S. Cho, “Selecting hydrogen production methods using fuzzy analytic hierarchy process with opportunities, costs, and risks,” *Int. J. Hydrogen Energy*, vol. 37, no. 23, pp. 17655–17662, 2012.
- [283] J. A. Alonso and M. T. Lamata, “Consistency in the analytic hierarchy process: A new approach,” *Int. J. Uncertainty, Fuzziness Knowledge-Based Syst.*, vol. 14, no. 4, pp. 445–459, 2006.
- [284] E. E. Noble and P. P. Sanchez, “A Note on the A note on the information content of a consistent pairwise comparison judgment matrix of an AHP decision maker,” *Theory Decis.*, vol. 34, no. 2, pp. 99–108, 1993.
- [285] T. L. Saaty, “Decision making with the analytic hierarchy process,” *Int. J. Serv. Sci.*, vol. 1, no. 1, pp. 83–98, 2008.
- [286] W. C. Wedley, “Consistency prediction for incomplete AHP matrices,” *Math. Comput. Model.*, vol. 17, no. 4–5, pp. 151–161, 1993.
- [287] D. Ho, G. Newell, and A. Walker, “The importance of property-specific attributes in assessing CBD office building quality,” *J. Prop. Invest. Financ.*, vol. 23, no. 5, pp. 424–444, 2005.
- [288] S. K. Sanyal, “Cost of Geothermal Power and Factors That Affect It,” in *Twenty-Ninth Workshop on Geothermal Reservoir Engineering*, 2004, pp. 1–12.
- [289] P. L. Yu, “A class of solutions for group decision problems,” *Manage. Sci.*, vol. 19, no. 8, pp. 936–946, 1973.
- [290] M. Zeleny, *Multiple Criteria Decision Making*. New York: McGraw-Hill, 1982.
- [291] R. V. Rao, “A decision making methodology for material selection using an improved compromise ranking method,” *Mater. Des.*, vol. 29, no. 10, pp. 1949–1954, 2008.
- [292] D. Siregar *et al.*, “Multi-Attribute Decision Making with VIKOR Method for Any Purpose Decision,” *J. Phys. Conf. Ser.*, vol. 1019, no. 1, 2018.
- [293] J. Wieckowski and W. Salabun, “How the normalization of the decision matrix influences the results in the VIKOR method?,” *Procedia Comput. Sci.*, vol. 176, pp. 2222–2231, 2020.
- [294] S. T. Mhlanga and M. Lall, “Influence of Normalization Techniques on Multi-criteria Decision-making Methods,” *J. Phys. Conf. Ser.*, vol. 2224, no. 1, 2022.
- [295] K. Menberg, S. Pfister, P. Blum, and P. Bayer, “A matter of meters: State of the art in the life cycle assessment of enhanced geothermal systems,” *Energy Environ. Sci.*, vol. 9, no. 9, pp. 2720–2743, 2016.
- [296] R. Cataldi, “Social acceptance: a sine qua non for geothermal development in the 21st

- century,” *Bull. d’Hydrogéologie*, vol. 17, no. 17, p. 17, 1999.
- [297] E. L. Majer *et al.*, “Induced seismicity associated with Enhanced Geothermal Systems,” *Geothermics*, vol. 36, no. 3, pp. 185–222, 2007.
- [298] R. DiPippo, “Geothermal energy Electricity generation and environmental impact,” *Energy Policy*, vol. 19, no. 8, pp. 798–807, 1991.
- [299] M. Khennich and N. Galanis, “Optimal design of ORC systems with a low-temperature heat source,” *Entropy*, vol. 14, no. 2, pp. 370–389, 2012.
- [300] B. Kovačić, “Matematika u MATLAB-u (Mathematics in MATLAB).” Zagreb, Croatia, p. 164, 2005.
- [301] T. Petković, “Kratke upute za korištenje MATLAB-a (Short instructions on MATLAB usage).” Zagreb, Croatia, 2005.
- [302] Y. University, “MATLAB Lesson 1.” [Online]. Available: <https://www.yorku.ca/jdc/Matlab/Lesson1.htm>. [Accessed: 13-Sep-2019].
- [303] I. Vujović, “Modeliranje i simuliranje u elektrotehnici MATLAB/Simulink (Modelling and simulation in electrical engineering MATLAB/Simulink).” Faculty of Maritime Studies, University of Split, Split, Croatia, 2014.
- [304] C. Moler, “MathWorks,” 2018. [Online]. Available: <https://www.mathworks.com/company/newsletters/articles/a-brief-history-of-matlab.html>. [Accessed: 14-Sep-2019].
- [305] H. Ghasemi, M. Paci, A. Tizzanini, and A. Mitsos, “Modeling and optimization of a binary geothermal power plant,” *Energy*, vol. 50, no. 1, pp. 412–428, 2013.
- [306] E. Kontoleonos, C. Karytsas, D. Mendrinou, and P. S. Georgilakis, “Optimized geothermal binary power cycles,” *J. Optoelectron. Adv. Mater.*, vol. 10, no. 5, pp. 1228–1232, 2008.
- [307] D. Walraven, B. Laenen, and W. D’Haeseleer, “Comparison of thermodynamic cycles for power production from low-temperature geothermal heat sources,” *Energy Convers. Manag.*, vol. 66, pp. 220–233, 2013.
- [308] D. Walraven, B. Laenen, and W. D’Haeseleer, “Optimum configuration of shell-and-tube heat exchangers for the use in low-temperature organic Rankine cycles,” *Energy Convers. Manag.*, vol. 83, pp. 177–187, 2014.
- [309] D. Walraven, B. Laenen, and W. D’haeseleer, “Minimizing the levelized cost of electricity production from low-temperature geothermal heat sources with ORCs: Water or air cooled?,” *Appl. Energy*, vol. 142, pp. 144–153, 2015.
- [310] “ENOGIA.” [Online]. Available: <https://enogia.com/en/home/>. [Accessed: 20-Aug-2021].
- [311] tec-science.com, “Final temperature of mixtures (Richmann’s law),” 2021. .
- [312] R. W. Whitesides, “PDH online Course: Process Equipment Cost Estimating By Ratio And Proportion,” 2020. [Online]. Available: [www.PDHcenter.com](http://www.PDHcenter.com).
- [313] R. Smith, *Chemical Process Design and Integration*, 2nd ed. John Wiley & Sons, 2016.
- [314] G. Towler and R. Sinnott, *Chemical Engineering Design: Principles, Practice, and Economics of Plant and Process Design*, 2nd ed. Butterworth-Heinemann (Elsevier), 2008.
- [315] R. Turton, J. Shaeiwitz, D. Bhattacharyya, and W. Whiting, *Analysis, Synthesis, and Design of Chemical Processes (International Series in the Physical and Chemical Engineering Sciences)*, 5th ed. 2018.
- [316] A. Toffolo, A. Lazzaretto, G. Manente, and M. Paci, “A multi-criteria approach for the optimal selection of working fluid and design parameters in Organic Rankine Cycle systems,” *Appl. Energy*, vol. 121, pp. 219–232, 2014.
- [317] U. Persson and S. Werner, “Heat distribution and the future competitiveness of district

- heating,” *Appl. Energy*, vol. 88, no. 3, pp. 568–576, 2011.
- [318] E. R. Institute, “Research Salaries.” [Online]. Available: <https://www.salaryexpert.com/salary>. [Accessed: 21-Jun-2020].
- [319] “Demonstration sites- Havelange,” *MEET Multi-site EGS Demonstration*, 2021. [Online]. Available: <https://www.meet-h2020.com/demonstration-sites/havelange/#1574437667328-2dabb306-1e4f>. [Accessed: 14-Nov-2021].
- [320] J. Hranić and S. Raos, “Deliverable 4.5: Methodology and tool for an economic evaluation of end-of-field life conversion,” 2021.
- [321] N. Pool, “Historical market data,” 2021. [Online]. Available: <https://www.nordpoolgroup.com/historical-market-data/>. [Accessed: 25-Nov-2021].
- [322] B. Rogiers, M. Huysmans, N. Vandenderghe, and M. Verkeyn, “Demonstrating large-scale cooling in a Variscan terrane by coupled groundwater and heat flow modelling,” *Geothermics*, vol. 51, pp. 71–90, 2014.
- [323] J. Reinecker, J. Gutmanis, A. Foxford, L. Cotton, C. Dalby, and R. Law, “Geothermal exploration and reservoir modelling of the United Downs deep geothermal project, Cornwall (UK),” *Geothermics*, vol. 97, pp. 1–27, 2021.
- [324] P. Ledingham, L. Cotton, and R. Law, “The United Downs Deep Geothermal Power Project,” in *44th Workshop on Geothermal Reservoir Engineering*, 2019.
- [325] J. H. Lienhard, M. A. Antar, A. Bilton, J. Blanco, and G. Zaragoza, “Solar desalination,” 2021.
- [326] Eurostat, “Gas prices for non-houshold consumer - bi-annual data,” 2021. [Online]. Available: <https://appsso.eurostat.ec.europa.eu/nui/submitViewTableAction.do>. [Accessed: 24-Nov-2022].
- [327] Statista, “Average monthly electricity wholesale prices in selected countries in the European Union (EU) from January 2020 to September 2021,” 2021. [Online]. Available: <https://www.statista.com/statistics/1267500/eu-monthly-wholesale-electricity-price-country/>. [Accessed: 30-Nov-2021].



# APPENDIX A

## A1. AHP supplementary data

The pairwise comparison matrices for criteria and sub-criteria level for all 35 respondents which passed consistency ration of 0.15. The individual pairwise matrices of each respondent for each cluster for each level of hierarchy were aggregated into a single representative matrix using the geometric mean.

Table A.1. Pairwise comparison matrix at the criteria level with respect to the goal

Criteria level	Geological setting	Technology	Economy/Finance	Society	Environment
Geological setting	1	2	1 1/3	2 1/5	1 3/4
Technology	1/2	1	3/4	1 1/2	1 2/9
Economy/Finance	3/4	1 1/3	1	1 8/9	1 1/2
Society	4/9	2/3	1/2	1	4/5
Environmental	4/7	5/6	2/3	1 1/4	1

Table A.2. Pairwise comparison matrix at the subcriteria level with respect to geological setting criterion

Geological setting	Permeability	Porosity	Reservoir type	Reservoir volume	Reservoir temperature	Reservoir depth	Fluid heat capacity
Permeability	1	2	2 1/5	1 1/2	1	1 3/5	1 3/5
Porosity	1/2	1	1 2/7	6/7	5/9	1	1
Reservoir type	1/2	7/9	1	3/4	3/7	3/4	4/5
Reservoir volume	2/3	1 1/6	1 1/3	1	2/3	1	1 1/7
Reservoir temperature	1	1 4/5	2 1/3	1 1/2	1	2	2 1/9
Reservoir depth	5/8	1	1 1/3	1	1/2	1	1 1/6
Fluid heat capacity	5/8	1	1 1/4	7/8	1/2	6/7	1

Table A.3. Pairwise comparison matrix at the subcriteria level with respect to technology criterion

Technology	Capacity factor	Deployment duration	Proximity to the grid	Global efficiency	Wellhead temperature	Flow rate	Injection temperature
Capacity factor	1	2 1/3	1 1/7	6/7	1	4/5	1 4/7
Deployment duration	3/7	1	2/3	4/9	1/2	4/9	1
Proximity to the grid	7/8	1 1/2	1	4/5	8/9	5/8	1 2/7
Global efficiency	1 1/6	2 1/5	1 1/4	1	1 1/3	1	2 1/6
Wellhead temperature	1	1 6/7	1 1/9	3/4	1	1	1 2/3
Flow rate	1 1/4	2 1/5	1 5/8	1	1	1	2
Injection temperature	5/8	1	7/9	1/2	3/5	1/2	1





Table A.4. Pairwise comparison matrix at the subcriteria level with respect to economy/finance criterion

<i>Economy/Finance</i>	LCOE/LCOH	NPV (EAA)	Capital costs	O&M costs	Discounted payback period	Support schemes
LCOE/LCOH	1	1	5/6	1 2/3	4/5	3/5
NPV (EAA)	1	1	1	2 1/8	1	4/5
Capital costs	1 1/5	1	1	2	1	7/9
O&M costs	3/5	1/2	1/2	1	3/7	4/9
Discounted payback period	1 1/4	1	1	2 1/3	1	4/5
Support schemes	1 2/3	1 1/4	1 2/7	2 1/4	1 1/4	1

Table A.5. Pairwise comparison matrix at the subcriteria level with respect to society criterion

<i>Society</i>	Job creation	Social acceptability
Job creation	1	67/72
Social acceptability	15/67	1

Table A.6. Pairwise comparison matrix at the subcriteria level with respect to environment criterion

<i>Environment</i>	Land use	Noise	Avoided CO <sub>2</sub> emission	Protected areas	Potential seismicity	Conflict with other subsurface uses
Land use	1	1 1/3	1/2	1/2	1/3	5/8
Noise	3/4	1	2/5	1/2	1/3	3/5
Avoided CO <sub>2</sub> emission	2	2 2/5	1	1	7/9	1 5/9
Protected areas	2	2 1/6	1	1	5/7	1 1/3
Potential seismicity	2 7/9	3	1 2/7	1 3/8	1	2 1/8
Conflict with other subsurface uses	1 3/5	1 2/3	2/3	3/4	1/2	1

The pairwise matrices are normalized, the consistency of each matrix is determined and the local weights, i.e. priority vector is calculated for each level of hierarchy (Table A.7 - Table A.12).

Table A.7. Normalized pairwise comparison matrix at the criteria level with respect to the goal

Criteria level	Geological setting	Technology	Economy/Finance	Society	Environment	Local weight
Geological setting	0.30506	0.34309	0.30986	0.28106	0.28052	<b>0.30392</b>
Technology	0.15392	0.17311	0.17747	0.19226	0.19450	<b>0.17825</b>
Economy/Finance	0.22905	0.22694	0.23265	0.24168	0.23614	<b>0.23329</b>
Society	0.13842	0.11482	0.12277	0.12753	0.12925	<b>0.12656</b>
Environmental	0.17356	0.14205	0.15725	0.15748	0.15960	<b>0.15799</b>

$$\lambda_{\max} = 5.01098, CI = 0.00274, CR = 0.00267$$



Table A.8. Normalized pairwise comparison matrix at the subcriteria level with respect to geological setting criterion

<i>Geological setting</i>	<b>Permeability</b>	<b>Porosity</b>	<b>Reservoir type</b>	<b>Reservoir volume</b>	<b>Reservoir temperature</b>	<b>Reservoir depth</b>	<b>Fluid heat capacity</b>	<b>Local weight</b>
<b>Permeability</b>	0.20432	0.22860	0.20394	0.20448	0.21083	0.19556	0.17998	<b>0.20396</b>
<b>Porosity</b>	0.10415	0.11652	0.11912	0.11486	0.12129	0.12653	0.12123	<b>0.11767</b>
<b>Reservoir type</b>	0.09355	0.09133	0.09337	0.09898	0.09349	0.09115	0.08997	<b>0.09312</b>
<b>Reservoir volume</b>	0.13276	0.13479	0.12533	0.13286	0.14192	0.12480	0.12880	<b>0.13161</b>
<b>Reservoir temperature</b>	0.21052	0.20868	0.21694	0.20335	0.21722	0.23568	0.23683	<b>0.21846</b>
<b>Reservoir depth</b>	0.12738	0.11227	0.12489	0.12979	0.11237	0.12191	0.13102	<b>0.12280</b>
<b>Fluid heat capacity</b>	0.12733	0.10781	0.11641	0.11570	0.10288	0.10436	0.11216	<b>0.11238</b>

$\lambda_{\max} = 7.01089$ , CI = 0.00181, CR = 0.00145

Table A.9. Normalized pairwise comparison matrix at the subcriteria level with respect to technology criterion

<i>Technology</i>	<b>Capacity factor</b>	<b>Deployment duration</b>	<b>Proximity to the grid</b>	<b>Global efficiency</b>	<b>Wellhead temperature</b>	<b>Flow rate</b>	<b>Injection temperature</b>	<b>Local weight</b>
<b>Capacity factor</b>	0.15833	0.19093	0.15189	0.16166	0.16279	0.14779	0.14870	<b>0.16030</b>
<b>Deployment duration</b>	0.06835	0.08242	0.08736	0.08577	0.08326	0.08411	0.09186	<b>0.08330</b>
<b>Proximity to the grid</b>	0.13810	0.12500	0.13249	0.15376	0.13880	0.11510	0.12048	<b>0.13196</b>
<b>Global efficiency</b>	0.18551	0.18203	0.16321	0.18942	0.20322	0.19851	0.20267	<b>0.18922</b>
<b>Wellhead temperature</b>	0.15003	0.15272	0.14725	0.14378	0.15426	0.17274	0.15882	<b>0.15423</b>
<b>Flow rate</b>	0.19951	0.18250	0.21436	0.17770	0.16631	0.18623	0.18341	<b>0.18715</b>
<b>Injection temperature</b>	0.10016	0.08440	0.10344	0.08791	0.09136	0.09551	0.09406	<b>0.09383</b>

$\lambda_{\max} = 7.02041$ , CI = 0.00340, CR = 0.00272

Table A.10. Normalized pairwise comparison matrix at the subcriteria level with respect to economy/finance criterion

<i>Economy/Finance</i>	<b>LCOE/LCOH</b>	<b>NPV (EAA)</b>	<b>Capital costs</b>	<b>O&amp;M costs</b>	<b>Discounted payback period</b>	<b>Support schemes</b>	<b>Local weight</b>
<b>LCOE/LCOH</b>	0.14723	0.16580	0.14936	0.14869	0.14388	0.13513	0.14835
<b>NPV (EAA)</b>	0.15520	0.17478	0.17731	0.18783	0.17242	0.18356	0.17518
<b>Capital costs</b>	0.17670	0.17669	0.17925	0.17059	0.19124	0.17625	0.17846
<b>O&amp;M costs</b>	0.08720	0.08194	0.09253	0.08806	0.07855	0.09971	0.08800
<b>Discounted payback period</b>	0.18693	0.18517	0.17122	0.20480	0.18267	0.17889	0.18495
<b>Support schemes</b>	0.24673	0.21562	0.23032	0.20001	0.23124	0.22646	0.22506

$\lambda_{\max} = 6.01103$ , CI = 0.00221, CR = 0.00190



Table A.11. Normalized pairwise comparison matrix at the subcriteria level with respect to society criterion

<i>Society</i>	<b>Job creation</b>	<b>Social acceptance costs</b>	<b>Local weight</b>
<b>Job creation</b>	0.48832	0.48832	<b>0.48832</b>
<b>Social acceptance costs</b>	0.51168	0.51168	<b>0.51168</b>

$\lambda_{\max} = 2.0000$ , CI = 0.0000, CR = 0.0000

Table A.12. Normalized pairwise comparison matrix at the subcriteria level with respect to environment criterion

<i>Environment</i>	<b>Land use</b>	<b>Noise</b>	<b>Avoided CO<sub>2</sub> emission</b>	<b>Protected areas</b>	<b>Potential seismicity</b>	<b>Conflict with other subsurface uses</b>	<b>Local weight</b>
<b>Land use</b>	0.09840	0.11718	0.10351	0.09716	0.09780	0.08577	<b>0.09997</b>
<b>Noise</b>	0.07302	0.08696	0.08248	0.08978	0.09360	0.08320	<b>0.08484</b>
<b>Avoided CO<sub>2</sub> emission</b>	0.19898	0.20995	0.20931	0.20264	0.21216	0.21425	<b>0.20788</b>
<b>Protected areas</b>	0.19813	0.18948	0.20206	0.19563	0.19705	0.18583	<b>0.19470</b>
<b>Potential seismicity</b>	0.27325	0.25230	0.26793	0.26962	0.27158	0.29305	<b>0.27129</b>
<b>Conflict with other subsurface uses</b>	0.15821	0.14413	0.13472	0.14517	0.12780	0.13790	<b>0.14132</b>

$\lambda_{\max} = 6.00375$ , CI = 0.00075, CR = 0.00065

For the detailed analysis of results by stakeholder group local weights of sub-criteria for each criteria group are presented in following figures (Figure A.1 - Figure A.5).

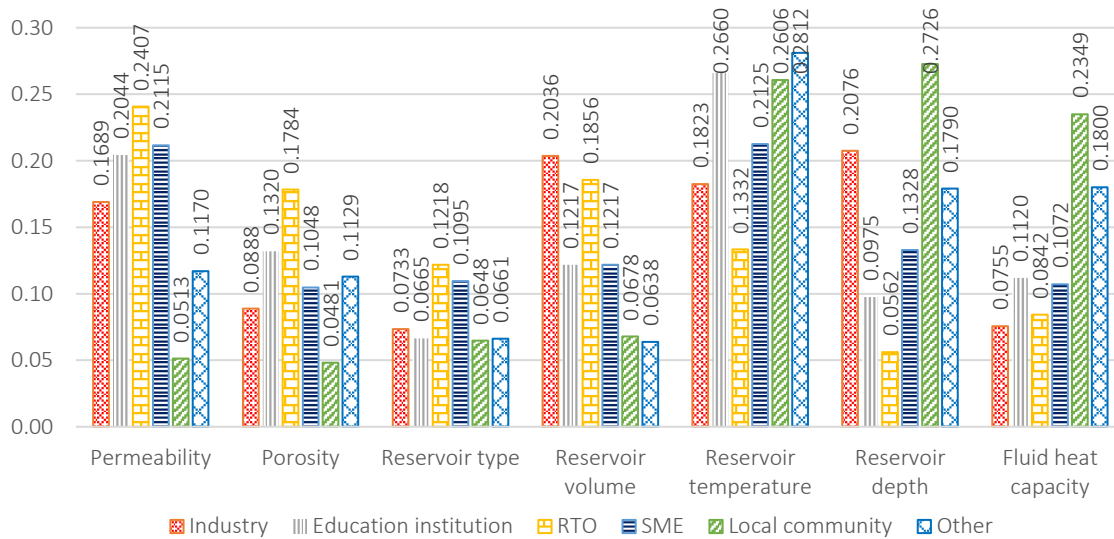

Figure A.1. Local weights for sub-criteria of geological setting criteria group by stakeholder group



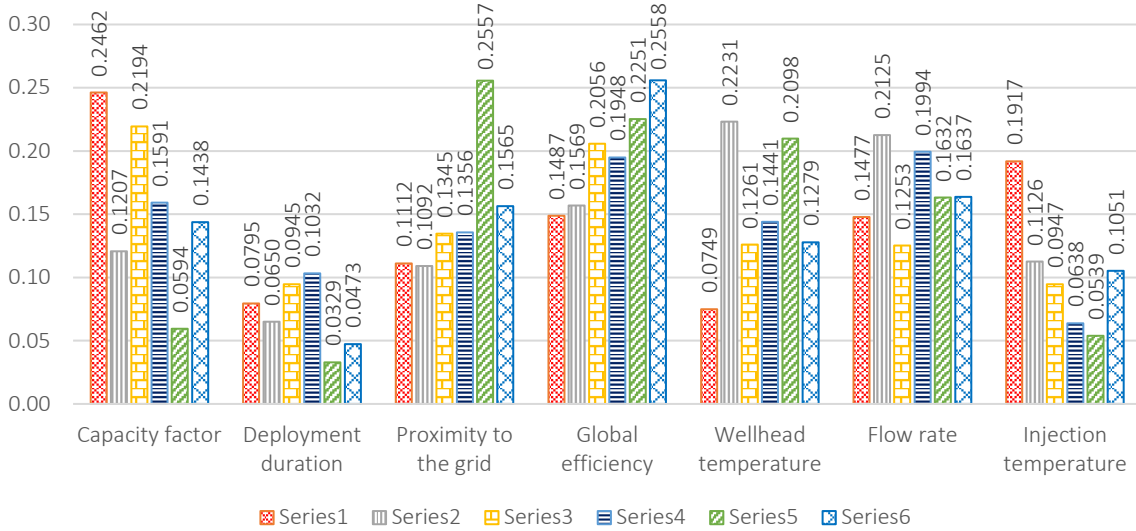

Figure A.2. Local weights for sub-criteria of technology criteria group by stakeholder group

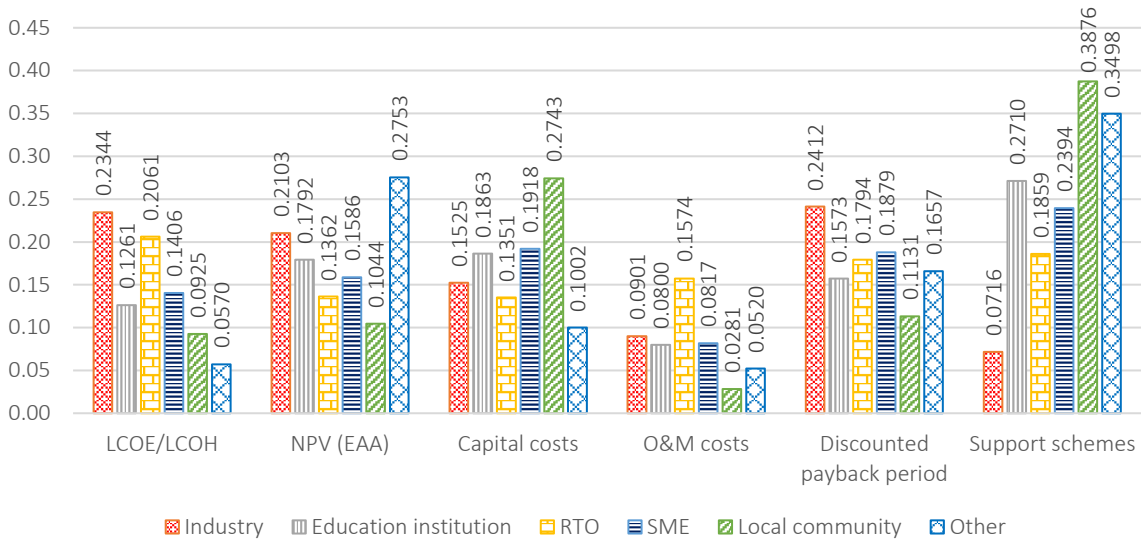

Figure A.3. Local weights for sub-criteria of economy/finance criteria group by stakeholder group

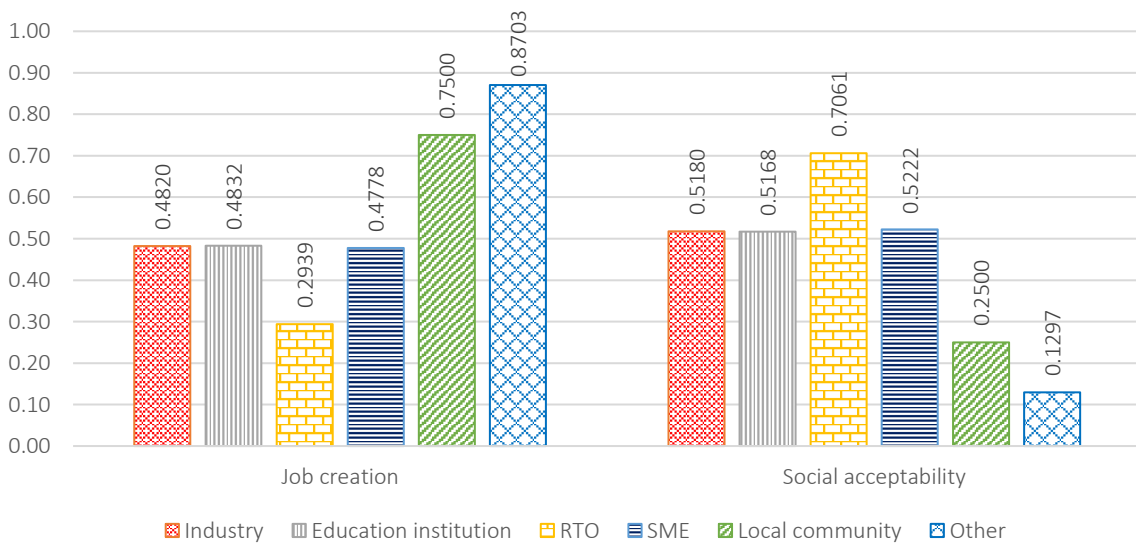

Figure A.4. Local weights for sub-criteria of the society criteria group by stakeholder group





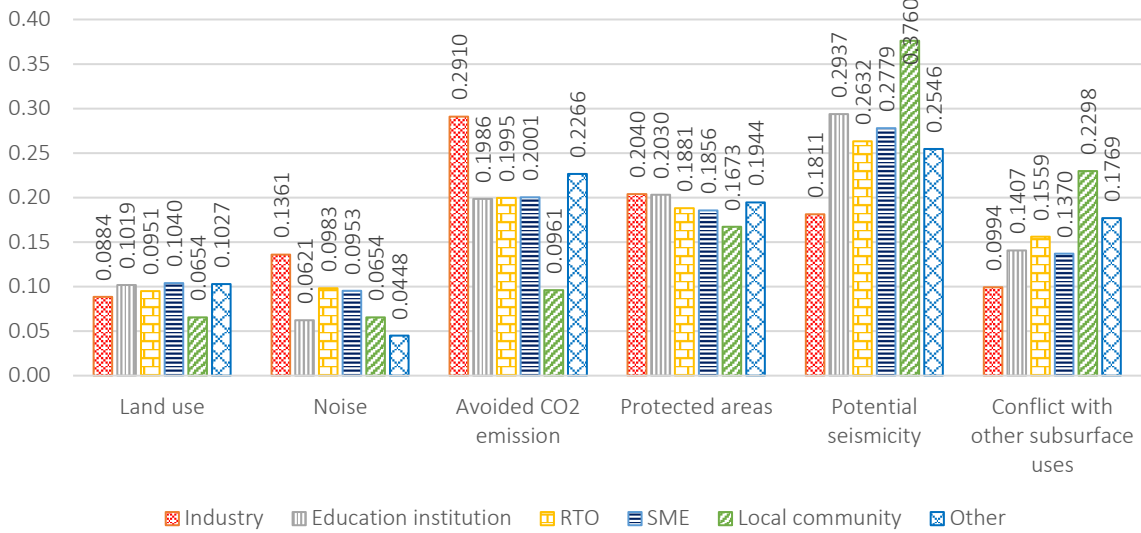

Figure A.5. Local weights for sub-criteria of the environment criteria group by stakeholder group

For the detailed analysis of results by group with and without geological background, local weights of sub-criteria for each criteria group are presented in following figures (Figure A.6- Figure A.10).

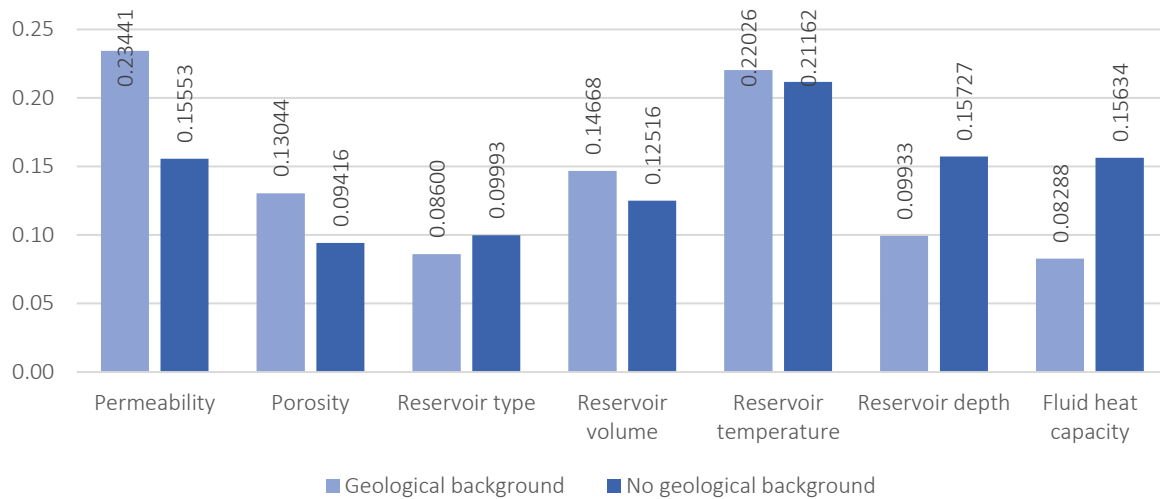

Figure A.6. Local weights for sub-criteria of geological setting criteria group by background group

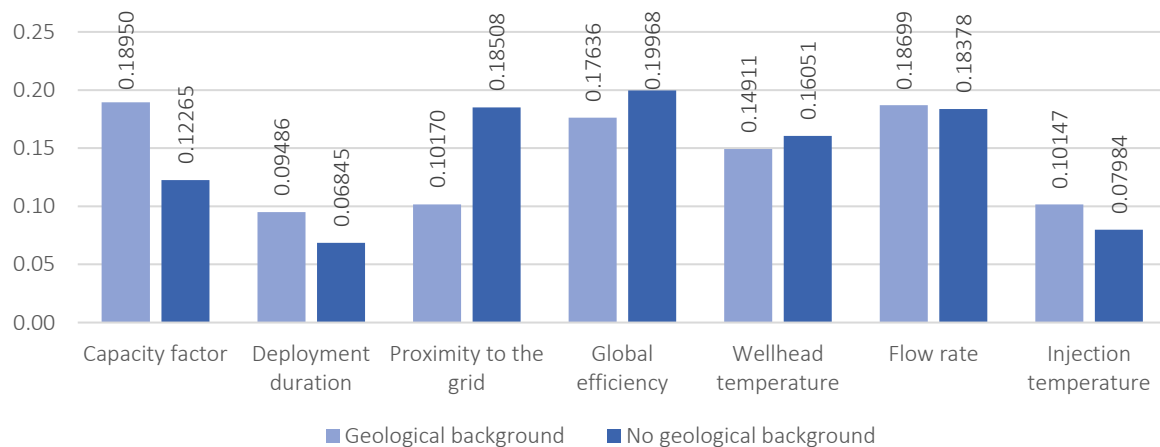

Figure A.7. Local weights for sub-criteria of technology criteria group by background group



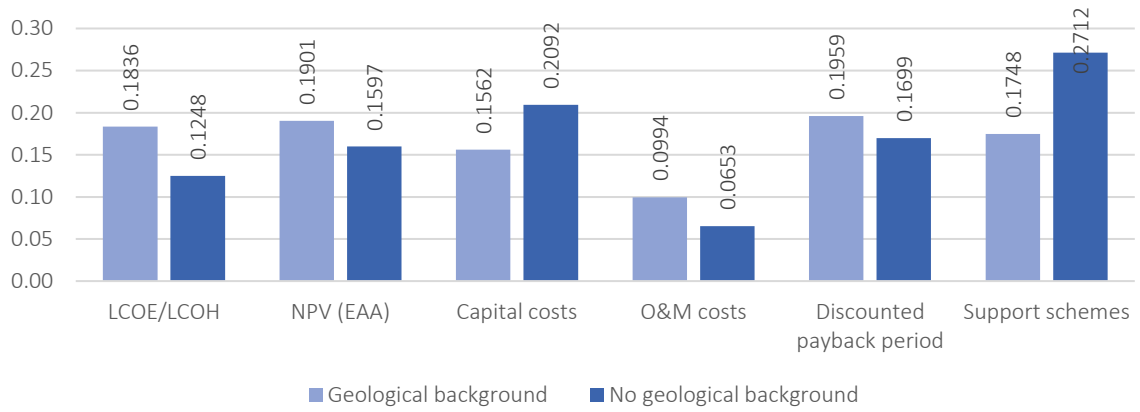

Figure A.8. Local weights for sub-criteria of economy/finance criteria group by background group

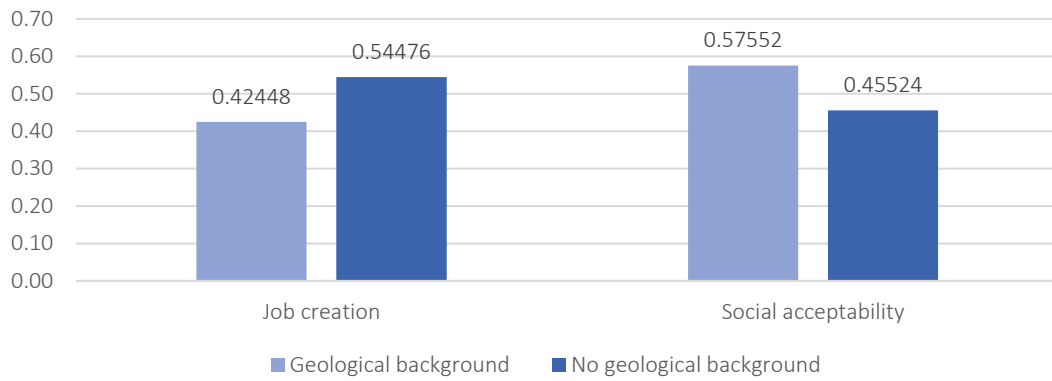

Figure A.9. Local weights for sub-criteria of society criteria group by background group

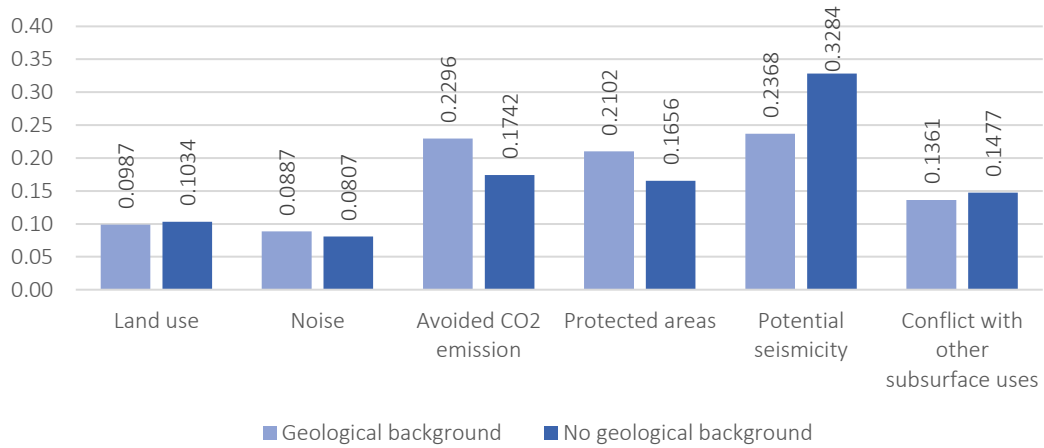

Figure A.10. Local weights for sub-criteria of environmental criteria group by background group



## Biography

SARA RAOS was born in 1993 in Zagreb, Croatia. She enrolled the Faculty of Electrical Engineering and Computing at University of Zagreb in 2012 and graduated in 2017 with magna cum laude (5% of the best students in the generation), becoming Master of Science in Electrical engineering and information technology (Profile: Electrical Power Engineering). During her Graduate study, she was receiving a scholarship for excellence from HEP (Croatian National Power Utility). After graduating, she worked for HEP and in 2018 she starts working at the Faculty of Electrical Engineering and Computing at the University of Zagreb, Department of Energy and Power Systems at the position of research associate. At the same time, she enrolls in postgraduate doctoral study of Electrical engineering and electrical engineering sciences at the same institution. From end of 2021 she is working at the Faculty of Electrical Engineering and Computing at the University of Zagreb, Department of Energy and Power Systems at the position of teaching assistant.

Her research interests include renewable energy sources with the emphasis on geothermal energy, long-term energy modelling, and economics of energy and power systems. Her research activities focus on the development of a comprehensive evaluation model for assessment of enhanced geothermal systems that could assist the decision-makers when assessing the potential investment in geothermal energy utilization projects, with emphasis on enhanced geothermal projects.

Sara has been involved in teaching activities as a teaching assistant in courses Economics of Power and Energy Systems, Energy Efficiency and Demand Side Management, Energy Policy Analysis and Modelling, and Energy and Socio-economic Development. She has also been supervising students in development of bachelor thesis.

She published 7 conference papers and presented them at domestic and international conferences. Additionally, she published 7 journal papers.

She was involved in several international projects: H2020 project MEET (Multidisciplinary and multi-context demonstration of EGS exploration and Exploitation Techniques and potentials), Interreg Danube Transnational Programme STRIDE project (Improved energy planning through the Integration of Smart Grid concepts in the Danube Region), and EUALC (Creation of a model for a transparent and cross-sectoral assessment of possible paths towards climate neutrality by 2050).



# Full list of publications

## JOURNAL PUBLICATIONS

1. Raos, Sara; Hranić, Josipa; Rajšl, Ivan; Bär, Kristian  
An extended methodology for multi-criteria decision-making process focused on enhanced geothermal systems. *Energy Conversion and Management*, 258 (2022); <https://doi.org/10.1016/j.enconman.2022.115253> (international peer-review, article, scientific)
2. Hranić, Josipa; Raos, Sara; Leoutre, Eric; Rajšl, Ivan  
Two-Stage Geothermal Well Clustering for Oil-to-Water Conversion on Mature Oil Fields. *Geosciences*, 11 (2021), 11; 470, 28 doi:10.3390/geosciences11110470 (international peer-review, article, scientific)
3. Ilak, Perica; Herenčić, Lin; Rajšl, Ivan; Raos, Sara; Tomšić, Željko  
Equilibrium Pricing with Duality-Based Method: Approach for Market-Oriented Capacity Remuneration Mechanism. *Energies*, 14 (2021), 567, 21 doi:10.3390/en14030567(international peer-review, article, scientific)
4. Tomšić, Željko; Raos, Sara; Rajšl, Ivan; Ilak, Perica  
Role of Electric Vehicles in Transition to Low Carbon Power System—Case Study Croatia. *Energies*, 2020, 13(24) (2020), 1-22 doi:.org/10.3390/en13246516 (international peer-review, article, scientific)
5. Bilić, Tena; Raos, Sara; Ilak, Perica; Rajšl, Ivan; Pašičko, Robert  
Assessment of Geothermal Fields in the South Pannonian Basin System Using a Multi-Criteria Decision-Making Tool. *Energies*, 13 (2020), 5; 1026-1049 doi:10.3390/en13051026 (international peer-review, article, other)
6. Raos, Sara; Ilak, Perica; Rajšl, Ivan; Bilić, Tena; Trullenque, Ghislain  
Multiple-Criteria Decision-Making for Assessing the Enhanced Geothermal Systems. *Energies*, 12 (2019), 9; 1597, 23 doi:10.3390/en12091597 (international peer-review, article, scientific)
7. Raos, Sara; Tomšić, Željko; Rajšl, Ivan  
The role of pumped-hydro storage power plants and large penetration of electric cars to increase the flexibility of the system with a large share of renewable energy sources. *Journal of Energy*, 66 (2017), Number 1-4; 128-149. (<https://www.bib.irb.hr/975628>) (international peer-review, article, scientific)





## CONFERENCE PUBLICATIONS

1. Raos, Sara; Hranić, Josipa; Rajšl, Ivan  
Methodology for oil-to-water conversion of mature oil fields and decision support tool. *2023 International Conference on Power and Renewable Energy Engineering (PREE 2022)*, Tokyo, Japan, 2023. (lecture, international peer-review, in-publishing (in extenso), scientific)
2. Raos, Sara; Hranić, Josipa; Rajšl, Ivan  
Evaluation model of enhanced geothermal system projects based on multi-criteria decision-making. *13<sup>th</sup> Mediterranean Conference on Power Generation, Transmission, Distribution and Energy Conversion (MEDPOWER 2022)*, Valletta, Malta, 2022. doi: 10.1049/icp.2022.3315 (lecture, international peer-review, published (in extenso), scientific)
3. Raos, Sara; Ilak, Perica; Rajšl, Ivan; Bilić, Tena; Trullenque, Ghislain  
Assessment of enhanced geothermal projects and their optimal long-term usage plans by using the DMS-TOUGE decision-making support tool. *European Geothermal Congress 2019*, Den Haag, Netherlands, (2019) [available online] <http://europeangeothermalcongress.eu/wp-content/uploads/2019/07/150.pdf> (poster, international peer-review, published (in extenso), scientific)
4. Bilić, Tena; Rajšl, Ivan; Ilak, Perica; Raos, Sara; Šadek, Siniša; Krajcar, Slavko; Debrecin, Nenad; Genter, Albert; Leoutre, Eric  
Overview of techno-economic issues of enhanced geothermal systems implementation and integration. *11<sup>th</sup> Mediterranean Conference on Power Generation, Transmission, Distribution and Energy Conversion (MEDPOWER 2018)*, Dubrovnik, Croatia, 2018. doi: 10.1049/cp.2018.1872 (lecture, international peer-review, published (in extenso), scientific)
5. Ilak, Perica; Raos, Sara; Rajšl, Ivan; Trullenque, Ghislain; Bilić, Tena; Šadek, Siniša; Marušić, Ante  
Economic and environmental assessment for enhanced geothermal systems integration into energy systems: Decision-making support tool for optimal usage of geothermal energy. *11<sup>th</sup> Mediterranean Conference on Power Generation, Transmission, Distribution and Energy Conversion (MEDPOWER 2018)*, Dubrovnik, Croatia, 2018. doi: 10.1049/cp.2018.1869 (lecture, international peer-review, published (in extenso), scientific)
6. Tomšić, Željko; Raos, Sara; Rajšl, Ivan  
Power System with Large Share of Renewable Energy Source and Role of Electric Vehicles in Increasing Power System Flexibility– Case Study Croatia. Digital proceeding: *The 13<sup>th</sup> Conference on Sustainable Development of Energy, Water and Environment Systems -SDEWES Conference*. Zagreb: Faculty of Mechanical Engineering and Naval Architecture, Zagreb, 2018. str. 0049-1(lecture, international peer-review, published (in extenso), scientific)
7. Raos, Sara; Tomšić, Željko; Rajšl, Ivan  
Uloga velike penetracije elektroautomobila u povećanju fleksibilnosti sustava s velikim udjelom obnovljivih izvora. 6. (12.) savjetovanje Hrvatskog ogranka Međunarodne elektrodistribucijske konferencije Zagreb: HO CIRED, 2018. str. SO5-02-1-SO5-02-10. (<https://www.bib.irb.hr/975698>)(lecture, domestic peer-review, published (in extenso), scientific)



## Životopis

SARA RAOS rođena je 1993. godine u Zagrebu, Hrvatska. Upisala je Fakultet elektrotehnike i računarstva Sveučilišta u Zagrebu 2012. godine i diplomirala je 2017. godine s odličnim uspjehom (*magna cum laude*), postavši magistrica tehničkih znanosti u području elektroenergetike i informacijske tehnologije (Profil: Elektroenergetika). Tijekom diplomskog studija dobila je stipendiju za izvrsnost od HEP-a (Hrvatska elektroprivreda). Nakon diplomiranja, radila je za HEP, a 2018. godine počela je raditi na Fakultetu elektrotehnike i računarstva Sveučilišta u Zagrebu, na Zavodu za visoki napon i energetiku, na poziciji znanstvenog suradnika. Istovremeno, upisala se u doktorski studij elektroenergetike na istom fakultetu. Od kraja 2021. godine radi na Fakultetu elektrotehnike i računarstva Sveučilišta u Zagrebu, na Zavodu za visoki napon i energetiku, na poziciji asistenta.

Njezini istraživački interesi uključuju obnovljive izvore energije s naglaskom na geotermalnu energiju, dugoročno modeliranje energetske sustava i ekonomiku energetske sustava. Njezine istraživačke aktivnosti usmjerene su na razvoj sveobuhvatnog modela za ocjenu poboljšanih geotermalnih sustava koji bi mogao pomoći donositeljima odluka pri procjeni potencijalnih investicija u projekte korištenja geotermalne energije, s naglaskom na projektima poboljšanih geotermalnih sustava.

Sara je uključena u nastavni proces kao asistentica na kolegijima Ekonomija u energetici, Energetska učinkovitost i upravljanje potrošnjom, Analiza i modeliranje energetske politike te Energija i društveno-gospodarski razvoj. Također je nadzirala studente u izradi završnih radova.

Objavila je 7 konferencijskih radova i prezentirala ih na domaćim i međunarodnim konferencijama. Također, objavila je 7 znanstvenih članaka.

Bila je uključena u nekoliko međunarodnih projekata: H2020 projekt MEET (eng. *Multidisciplinary and multi-context demonstration of EGS exploration and Exploitation Techniques and potentials*), Interreg Dunavski transnacionalni program projekt STRIDE (Energetsko planiranje integracijom koncepata pametne mreže u Dunavskoj regiji) i projekt EUALC (Izrada modela za transparentnu i međusektorsku procjenu mogućih puteva prema klimatskoj neutralnosti do 2050. godine).