

# Optimal energy and reserves scheduling through controllable charging and discharging a fleet of electric vehicles

---

Pavić, Ivan

Doctoral thesis / Disertacija

2021

*Degree Grantor / Ustanova koja je dodijelila akademski / stručni stupanj:* **University of Zagreb, Faculty of Electrical Engineering and Computing / Sveučilište u Zagrebu, Fakultet elektrotehnike i računarstva**

*Permanent link / Trajna poveznica:* <https://urn.nsk.hr/urn:nbn:hr:168:020791>

*Rights / Prava:* [In copyright](#) / [Zaštićeno autorskim pravom.](#)

*Download date / Datum preuzimanja:* **2024-07-14**



*Repository / Repozitorij:*

[FER Repository - University of Zagreb Faculty of Electrical Engineering and Computing repozitory](#)





University of Zagreb

FACULTY OF ELECTRICAL ENGINEERING AND COMPUTING

Ivan Pavić

**OPTIMAL ENERGY AND RESERVES  
SCHEDULING THROUGH CONTROLLABLE  
CHARGING AND DISCHARGING OF A FLEET OF  
ELECTRIC VEHICLES**

DOCTORAL THESIS

Zagreb, 2021



University of Zagreb

FACULTY OF ELECTRICAL ENGINEERING AND COMPUTING

Ivan Pavić

**OPTIMAL ENERGY AND RESERVES  
SCHEDULING THROUGH CONTROLLABLE  
CHARGING AND DISCHARGING OF A FLEET OF  
ELECTRIC VEHICLES**

DOCTORAL THESIS

Supervisor: Professor Igor Kuzle, PhD

Zagreb, 2021



Sveučilište u Zagrebu  
FAKULTET ELEKTROTEHNIKE I RAČUNARSTVA

Ivan Pavić

**ODREĐIVANJE OPTIMALNOGA RASPOREDA  
NABAVE ENERGIJE TE PRUŽANJA REZERVE  
KROZ UPRAVLJIVO PUNJENJE I PRAŽNENJE  
FLOTE ELEKTRIČNIH VOZILA**

DOKTORSKI RAD

Mentor: Prof. dr. sc. Igor Kuzle

Zagreb, 2021.



The doctoral thesis was completed at the University of Zagreb Faculty of Electrical Engineering and Computing, Department of Energy and Power Systems, Zagreb, Croatia

Supervisor: Professor Igor Kuzle, PhD

The thesis has: 207 pages

Thesis number: \_\_\_\_\_

## About the Supervisor

Igor Kuzle ([www.fer.unizg.hr/en/igor.kuzle](http://www.fer.unizg.hr/en/igor.kuzle)) is a full professor at the Department of Energy and Power Systems of the University of Zagreb's Faculty of Electrical Engineering and Computing (FER). He was born in 1967 in Tuzla. He received the B.Sc. degree in 1991, the M.Sc. degree in 1997, and the Ph.D. degree in electrical engineering in 2002 from FER, where he has worked continuously since July 1992. He is a member of two scientific councils of Croatian Academy of Sciences and Arts (Scientific Council for Technological Development and Scientific Council for Crude Oil and Gas Economy and Power Supply). He has been an associate member of Croatian Academy of Engineering since 2017. Prof. Kuzle was awarded the Croatian National Science Award for the year 2018 for his outstanding contribution in the field of smart grid applications in the transmission system. In 2016, he received annual Science award from the Faculty of Electrical Engineering and Computing for outstanding achievement in research or innovation in the last five years in the field of smart grid flexibility. In 2019, he received the Excellence in Engineering Award from the Croatian Academy of Sciences and Arts. The award recognizes work in the field of applying various control concepts to increase the flexibility of the power system and further integrate renewable energy sources. At the University of Zagreb, he is a member of the Committee for Science and International Cooperation and Vice President for Science of the Scientific Field Committee for Electrical Engineering and Computer Science of the National Agency for Science and Higher Education, which evaluates the scientific contribution of candidates in the selection process of university professors in Croatia.

He has participated in seven scientific projects of the Ministry of Science, Education and Sports of the Republic of Croatia, three Croatian Science Foundation (HRZZ) projects, one innovation and development (IRI) project of the European Regional Development Fund, three EU FP7 and three H2020 projects. Currently he is the project coordinator for Croatian partners at H2020 project CROSSBOW, project coordinator of IRI project KONPRO 2 and project leader of the HRZZ research project WINDLIPS and one Croatia-China bilateral project WIND ASP.

At the University of Zagreb, Prof. Kuzle has established the research laboratory Smart Grids Laboratory, which enables practical research in the field of Smart Grids (virtual storage plant, virtual power plant, different generation mixes of renewable energy sources, demand response, islanding and parallel operation, ac/dc microgrids, etc.).

His scientific interests include problems in dynamics and control of electrical power systems, maintenance of electrical equipment, as well as smart grids and integration of renewable energy sources.

He serves on 8 journal editorial boards and acts as a technical reviewer for several international journals. Igor Kuzle published 4 books and more than 400 journal and conference papers,

---

including technical studies and reports for utilities and private companies (project manager for more than 80 technical projects). He has chaired 6 international conferences (IEEE SGSMA 2022, CGEE 2021, CGEE 2020, IET Medpower 2018, IEEE Energycon 2014, IEEE Eurocon 2013) and the national 11th HRO CIGRÉ Session 2013 and served as a chair of the Local Organizing Committee at conferences PAC World 2014 and European Energy Market 2011. He participated in more than 60 conferences' International Scientific /Technical or Steering Committees and gave over 20 keynote lectures.

Since 2012, he has been a member of the Expert Advisory Committee of the Ministry of Environmental and Nature Protection in assessing the environmental impact of RES and a member of the Coordination Group of Croatian Transmission System Operators for the Connection of Renewable Energy Sources. He is a member of the technical commission for awarding the Croatian quality mark Croatian Chamber of the Ministry of Economy and a member of Croatian Chamber of Electrical Engineers and since 1994 a member of Licensed Engineer.

He is a very active member of IEEE, the world's largest engineering association (with more than 400,000 members), where he has held various positions. In period 2015-2016 he was IEEE Region 8 Vice Chair for technical activities, IEEE Croatia Section Chair (2009-2012), and from 2021 he has been the representative of all IEEE Power and Energy Chapters of Europe, Africa and the Middle East. Prof. Kuzle is an associate member of the Croatian Academy of Engineering (HATZ) and a member of the professional association CIGRE (2009-2012 member of the Croatian National Committee CIGRE Executive Board). Since 2019 he has been a member of the Steering Committee of Croatian Maintenance Society.

- <https://orcid.org/0000-0001-8992-4098>
- <https://scholar.google.hr/citations?user=NJZpB50AAAAJ&hl>
- [https://www.researchgate.net/profile/Igor\\_Kuzle](https://www.researchgate.net/profile/Igor_Kuzle)
- <https://www.scopus.com/authid/detail.uri?authorId=6603294176>
- <https://publons.com/researcher/1292088/igor-kuzle/>

## O mentoru

Igor Kuzle ([www.fer.unizg.hr/igor.kuzle](http://www.fer.unizg.hr/igor.kuzle)) je redoviti profesor u trajnom zvanju na Zavodu za visoki napon i energetiku, Sveučilišta u Zagrebu Fakulteta elektrotehnike i računarstva (FER). Rodio se je u Tuzli 1967. godine. Diplomirao je, magistrirao i doktorirao u polju elektrotehnike 1991., 1997. odnosno 2002. godine na FER-u, gdje u kontinuitetu radi od srpnja 1992. godine. Član je dva znanstvena vijeća Hrvatske akademije znanosti i umjetnosti (HAZU), Znanstvenog vijeća za tehnološki razvoj i Znanstvenog vijeća za naftno-plinsko gospodarstvo i energetiku.

Prof. Kuzle je nagrađen Nacionalnom nagradom za znanost 2018. godine za svoj doprinos znanosti u području naprednih mreža u prijenosnom sustavu te 2016. Nagradom za znanost FER-a za svoj izniman istraživački doprinos i inovacije u razdoblju od 2010 do 2015. u području fleksibilnosti naprednih elektroenergetskih mreža. Dobitnik je nagrade HAZU za 2019. godinu za znanstveni doprinos iz primjene različitih koncepata upravljanja naprednim elektroenergetskim mrežama u svrhu povećanja fleksibilnosti elektroenergetskog sustava te omogućavanja masovne integracije obnovljivih izvora energije. Član je Odbora za znanost i međunarodnu suradnju Sveučilišta u Zagrebu te dopredsjednik za znanost Matičnog odbora za elektrotehniku i računarstvo Nacionalnog vijeća za znanost, visoko obrazovanje i tehnološki razvoj.

Sudjelovao je na sedam znanstvenih projekata Ministarstva znanosti, obrazovanja i sporta (MZOS) Republike Hrvatske, tri projekta Hrvatske zaklade za znanost (HRZZ), jednom inovacijsko razvojnom (IRI) projektu Europskog fonda za regionalni razvoj, tri EU FP7 i tri H2020 projekta. Trenutno je koordinator hrvatskih partnera na H2020 projektu CROSSBOW, koordinator IRI projekta KONPRO 2 i voditelj HRZZ istraživačkog projekta WINDLIPS financiranog od Hrvatske naklade za znanost te jednog bilateralnog projekta s Republikom Kinom WIND ASP.

Na Sveučilištu u Zagrebu prof. Kuzle je ustrojio istraživački Laboratorij za napredne elektroenergetske mreže koji omogućava praktična istraživanja iz područja naprednih pametnih mreža (virtualni spremnik energije, virtualna elektrana, različite proizvodne kombinacije obnovljivih izvora energije, odziv potrošnje, otočni i paralelni rad sa sustavom, ac/dc mikro mrežu itd.).

Istražuje probleme iz područja dinamike i regulacije elektroenergetskih sustava, održavanja elektroenergetske opreme, naprednih mreža te integracije obnovljivih izvora energije.

Član je uredničkih odbora osam znanstvenih časopisa te sudjeluje kao recenzent u većem broju inozemnih časopisa. Objavio je četiri knjige i više od 400 radova u časopisima i na konferencijama uključujući i tehničke studije i elaborate za komunalne tvrtke i industriju (bio je voditelj više od 80 projekata). Bio je ili je predsjedavajući šest međunarodnih konferencija (IEEE SGSM 2022, CGEE 2021, CGEE 2020, IET Medpower 2018, IEEE Energycon

---

2014, IEEE Eurocon 2013) te 11. nacionalnog savjetovanja HRO CIGRÉ 2013. godine kao i predsjednik Lokalnog organizacijskog odbora konferencija PAC World 2014 i European Energy Market 2011. Bio je član u više od 60 međunarodnih programskih/ tehničkih ili upravnih odbora znanstvenih konferencija, a održao je i više od 20 pozvanih predavanja.

Od 2012. član je stručnog savjetodavnog odbora za procjenu utjecaja na okoliš obnovljivih izvora energije Ministarstva zaštite okoliša i energetike (MZOE) te član Odbora za priključak obnovljivih izvora energije Hrvatskog operatora prijenosnog sustava (HOPS). Član je odbora za dodjelu znaka „Hrvatska kvaliteta“ Hrvatske gospodarske komore te je član Hrvatske komore inženjera i ovlaštenu inženjer od 1994.

Posebno je aktivan u najvećoj svjetskoj inženjerskoj udruzi IEEE (s više od 400.000 članova) gdje je obnašao više dužnosti. U periodu 2015.-2016. bio je dopredsjednik za tehničke aktivnosti IEEE Regije 8, 2009.-2012. predsjednik Hrvatske sekcije IEEE, a od 2021. predstavnik je svih Odjela za energetiku Europe, Afrike i Bliskog Istoka. Član suradnik je Akademije tehničkih znanosti Hrvatske (HATZ) te član stručne udruge CIGRE (2009-2012 član izvršnog odbora hrvatskog ogranka CIGRE). Od 2019. član je Upravnog odbora Hrvatskog društva održavatelja.

- <https://orcid.org/0000-0001-8992-4098>
- <https://scholar.google.hr/citations?user=NJZpB50AAAAJ&hl>
- [https://www.researchgate.net/profile/Igor\\_Kuzle](https://www.researchgate.net/profile/Igor_Kuzle)
- <https://www.scopus.com/authid/detail.uri?authorId=6603294176>
- <https://publons.com/researcher/1292088/igor-kuzle/>

## **Preface**

Throughout the writing of this dissertation I have received a great deal of support and assistance.

I would first like to thank my supervisor prof. Igor Kuzle for his mentoring throughout my doctoral research. I would also like to express my sincere gratitude to professors Tomislav Capuder and Hrvoje Pandžić for providing me guidance and feedback in all my academic quests, projects and publications.

Many thanks to my colleagues from Department of Energy and Power Systems at FER, especially my coworkers and officemates Matija Zidar, Ninoslav Holjevac and Matej Krpan, for vigorous technical and nontechnical discussions which ultimately help me to frame this dissertation.

I would like to thank my friends and family, especially my wife Matea and our sons Bartol and Juraj, for their continuous counsel and support.

## Abstract

The increasing share of electric vehicles (EV) creates new challenges for both the power and the transport systems. The power system is affected at multiple levels, from distribution and transmission grid operation, through new balancing efforts, up to the long-term power system adequacy issues. EVs can request significant cumulative charging power at specific hours, such as after the evening trips when most of the people drive from work to home and connect their vehicles to home chargers. Roughly at the same period, the peak power consumption occurs. If the charging process is not managed adequately, the EVs could end up taking large portions of energy when the power system is already under significant stress and when the prices are peaking. This is often referred to as uncontrolled or dumb charging. Smart charging is proposed as an alternative to prevent negative effects and to provide new opportunities to the power system and to the EV users.

Smart charging is a charging process that takes into account the current power system condition and behaves accordingly. The main inputs to the smart charging process are energy and ancillary services prices which represent the current status of the power system. If the resources are scarce, prices rise, while if the system has abundance of unused resources they fall (and can even become negative). When the energy prices are high, the charging (under the smart charging scheme) is postponed to later lower-price periods. Apart from moving charging to less costly times, the EVs can also have a possibility to discharge during the high-price periods and receive income. Such charging/discharging is related to dynamic electricity prices, whether wholesale prices or retail tariffs. However, the smart charging can unleash its full potential through ancillary services provision to distribution or transmission system operators. Provision of reserves and balancing energy stands as the most prominent ancillary service that can be achieved from the charging process. These services are more dynamic than the energy-only trading as they are activated on an explicit request from the transmission system operator. The profitability of those services depends on a set of prices, availability and activation fees, as well as on the amount of actually activated energy.

This thesis deals with three challenges related to smart EV charging and provision of the balancing services: the physical effect on the power system, the adequate enabling concept and the market positioning strategies. The first challenge is to check how different charging strategies effect the power system operation for different electricity mixes, different electric vehicles and renewable penetration levels, different power plant decommission policies, renewable policies etc. In general, the smart EV charging provides direct benefits such as decreased overall costs and greenhouse gas emissions plus additional positive effects such as less cycling and flatter operation for the large power plants.

The second challenge refers to the definition of the e-mobility concept that yields the high-

---

est overall potential in terms of the flexibility provision. The term *flexibility* refers to the ability of a unit to change its parameters, primarily active power output (technically viable with negligible economic loss). The conventional concept observes the charging stations as the active power system participants (EVs are merely an flexibility providing instrument) and it has several obstacles when the flexibility is at stake. The biggest issue is that the stations do not see or control the EVs' behavior when they are detached from the charging stations and therefore cannot optimally schedule the EVs' flexibility provision at any time. In the thesis, a new concept is proposed based on EVs as active participants and charging stations merely as an enabling infrastructure. The main advantage of the new concept is that it follows the EVs' throughout day and can optimally schedule all potential services.

The last challenge is in development of market positioning algorithms for simultaneous electricity and reserve provision. Special attention was placed on reserve activation modeling in such algorithms as this was a neglected area in both the technical and the research literature. Reserve activation is an extremely stochastic parameter albeit highly important when deciding how and when to place bids. In the thesis, stochastic and robust models have been built that can efficiently take into account this uncertainty. Both models demonstrated superior results as compared to the baseline deterministic model. However, the robust model seems to be a better choice for this specific purpose due to better computational tractability and risk hedging manageability.

**Keywords:** Electric Vehicles, Ancillary Services, Reserves, Balancing Energy, Smart Charging



# **Određivanje optimalnoga rasporeda nabave energije te pružanja rezerve kroz upravljivo punjenje i pražnjenje flote električnih vozila**

Povećani udio električnih vozila (EV) stvara nove izazove i za elektroenergetski i za cestovni transportni sustav. E-mobilnost utječe na elektroenergetski sustav na nekoliko razina, od pogona distribucijske i prijenosne mreže, kroz nove zahtjeve za uravnoteženjem do problema dugoročne dostatnosti cijelog sustava. Stanice za punjenje električnih vozila se priključuju na distribucijsku razinu, bilo da se radi o malim kućni ili velikim brzim punionicama, te mogu utjecati na strujno-naponske prilike lokalne distribucijske mreže. Problem se može prolongirati i na pojnu prijenosnu mrežu u kojoj može doći do povećanih tokova djelatne i jalove snage te, shodno tome, strujnih i naponskih zagušenja. Nove zahtjeve za punionicama treba odmah uzeti u obzir prilikom izrade dugoročnih planova razvoja mreže kako bi se prevenirali ovakvi neželjeni događaji. Druga opcija je uzeti u obzir fleksibilnost koja se može iskoristiti iz malih distribuiranih izvora te na taj način u pogonu otkloniti spomenute mrežne probleme. Pri tom je potrebno organizirati tržišta za pružanje fleksibilnosti i distribucijskoj i prijenosnoj mreži neovisna o tržištima energije.

Osim razvoja mreže, porast broja električnih vozila i njihovih punjača mora se uzeti u obzir i u proračunima dostatnosti cijelog sustava kako dugoročno ne bi došlo do nedostatka proizvodnih i međudržavnih interkonekcijskih kapaciteta u specifičnim slučajevima. Danas postoje tzv. "mehanizmi kapaciteta" koji na različite načine nagrađuju kapacitet koji se može aktivirati kako bi se pokrilo najveće opterećenje u sustavu. Potrošnja električne energije u punionicama obiluje varijabilnosti i nepredvidivosti. Varijabilnost je povezana s obrascima korištenja cestovnih vozila te se jasno očituju pojačane aktivnosti u jutarnjim i poslijepodnevni satima (dnevne migracije na posao i posla) te vrlo niska aktivnost u noćnim satima. Nepredvidivost je povezana s otežanim predviđanjem vremena punjenja koje dolazi od stohastičke naravi ljudskog ponašanja, ali i od ostalih uvjeta poput stanja u prometu, temperature zraka (u hladnim periodima veća potrošnja radi grijanja vozila), tehničke naravi baterija (veći gubici van optimalnog temperaturnog raspona i stanja napunjenosti) itd. Varijabilnost i nepredvidivost potrošnje na punionicama mogu dovesti do pojačanih zahtjeva za kapacitetom uravnoteženja (rezervom) te energijom uravnoteženja. Naime, kapacitet uravnoteženja operator prijenosnog sustava ugovara unaprijed (prije stvarne isporuke) čime si osigurava dovoljne količine energije uravnoteženja radi uravnoteženja proizvodnje i potrošnje u stvarnom vremenu. Ukoliko se ta ravnoteža naruši može doći do frekvencijskih problema te u najgorem slučaju čak i do urušavanja sustava (engl. "black-out").

Električna vozila mogu zahtijevati značajnu kumulativnu snagu iz elektroenergetskog sus-

---

tava ponajviše zbog visoke istovremenosti korištenja vozila, odnosno visoke istovremenosti parkiranja istih na punionice, npr. nakon poslijepodnevnog puta kući s posla većina vozila se priključuje na punjače. Otprilike u isto vrijeme nastaje i vršno opterećenje u elektroenergetskom sustavu iz istog razloga istovremenosti ljudskog ponašanja, npr. većina ljudi ulazi u kuću te uključuju svjetlo, tv, pećnicu, klima uređaj, grijanje itd. Ako se procesom punjenja adekvatno ne upravlja, električna vozila se mogu naći u stanju da preuzimaju značajne količine energije u trenutcima kada je sustav ionako vrlo opterećen i kada su cijene vrlo visoke. Ovaj način punjenja se često naziva neupravljivo (engl. "Uncontrolled Charging") ili glupo punjenje (engl. "Dumb Charging"). Cilj elektrifikacije prometnog sustava (smanjenje emisija stakleničkih plinova) se neupravljivim punjenjem anulira jer se problemi povećavaju na strani elektroenergetskog sustava. Povećanje vršnog opterećenja kao rezultat može imati povećane potrebe za ulaganjem u mrežnu infrastrukturu (vodovi, transformatorske stanice itd.) ili u proizvodnu infrastrukturu (nove upravljive plinske jedinice itd.). Pametno punjenje (engl. "Smart Charging") je predloženo kao alternativa kako bi se prevenirale negativne posljedice elektrifikacije prometnog sektora te omogućile dodatne mogućnosti kako za elektroenergetski sustav tako i za korisnike vozila.

Pametno punjenje je proces punjenja električnih vozila koji uzima u obzir stanje u elektroenergetskom sustavu te mu se prilagođava. Osnovni ulazni parametri takvom punjenju, sa strane elektroenergetskog sustava, su cijene energije i pomoćnih usluga koje predstavljaju trenutno stanje elektroenergetskog sustava. Ako vlada oskudica resursima, cijene su visoke, ako pak postoji izobilje resursa, cijene su niske (mogu biti čak i negativne). Kada su cijene energije visoke, punjenje se odgađa (unutar koncepta pametnog punjenja) u periode niskih cijena. Osim pomicanja punjenja u periode niskih cijena, električna vozila mogu imati i mogućnost pražnjenja u mrežu za vrijeme visokih cijena kako bi dodatno zaradila. Ovakav način se u literaturi često označava kao vozilo-prema-mreži koncept (engl. „Vehicle-to-grid“, V2G) naspram jednosmjernog načina koji se često označava kao mreža-prema-vozilu koncept (engl. „Grid-to-vehicle“, G2V). Oba načina temelje se na promjenjivosti cijena energije, bilo da se radi o veleprodajnim dan-unaprijed cijenama sa burzi električne energije ili maloprodajnih opskrbnih/mrežnih tarifa. Bitno je spomenuti da pri negativnim cijenama energije punjenje električnih vozila ne predstavlja trošak već prihod (negativne cijene su sve češća pojava na razvijenim energetske tržištima).

Navedeni koncepti, osim na energetska tržišta odnose se i na pružanje pomoćnih usluga distribucijskim i prijenosnim operatorima sustava pri čemu se ostvaruje puni potencijal pametnog punjenja. Pružanje kapaciteta i energije uravnoteženja najistaknutije su pomoćne usluge koje se mogu ostvariti kroz pametno punjenje. Ako su cijene kapaciteta ili energije uravnoteženja visoke, punjenje električnih vozila prilagođava se tako da se tada maksimalno pružaju te usluge. Zanimljiva je vrlo česta pojava, u mnogim zemljama u Europi, da je cijena negativne en-

---

energije uravnoteženja negativna, što ponovno znači da se punjenjem električnih vozila zarađuje. Ove pomoćne usluge su značajno dinamičnije od čistog energetskog trgovanja jer se aktiviraju izravno na zahtjev operatora prijenosnog sustava (ili promjenu frekvencije). Postoji velik broj pilot projekata u Europi koji se bave upravo pružanjem kapaciteta/energije uravnoteženja gdje se osim tehničke izvedivosti definira i isplativost koncepta. Isplativost ovisi o dva seta cijena, cijene za dostupnost te aktivaciju, kao i o volumenu stvarno aktivirane energije. Aktivacija ovih usluga je vrlo nepredvidiva te je vrlo bitno imati adekvatne tržišne modele kako bi električna vozila bila u stanju pružiti sve ugovorene usluge bez narušavanja komfora korisnika električnih vozila (nedovoljna energija za putovanje itd.). Ako korisnik ne želi unaprijed prodati svoj kapacitet punjenja ili pražnjenja kao uslugu kapaciteta uravnoteženja, moguće je trgovati i samo energijom uravnoteženja kroz slobodne ponude (engl. "Free bids"). Tada se odluke donose u stvarnom vremenu kada je korisnik siguran da mu neće biti potrebno vozilo u sljedećem vremenskom periodu.

Osnovna postavka za ovakav način rada jest da punjači tehnički moraju biti drugačije dizajnirani, odnosno moraju biti dvosmjerni te popraćeni odgovarajućom informacijsko-komunikacijskom infrastrukturom. Ovakvi punjači nešto su skuplji od klasičnih jednosmjernih, no prema dostupnoj literaturi, kod pružanja i arbitraže i kapaciteta/energije uravnoteženja, dodatna investicija je često opravdana (što ovisi o uvjetima na pojedinim tržištima). Bitan aspekt jest i pitanje dodatne degradacije baterije uslijed povećanja broja ciklusa punjenja-pražnjenja. Naime, litij ionske baterije degradiraju kalendarski i operativno. Najveći efekt kod degradacije imaju dubina pražnjenja, snage punjenja i pražnjenja te temperatura. Kod učestalih dubokih pražnjenja skraćuje im se životni vijek što se mora uzeti u obzir tijekom proračuna isplativosti.

Kako bi se ostvarilo pametno punjenje, potrebni su i dodatni inputi od strane korisnika. Potrebno je znati sve tehničke podatke o vozilu, snaga punjača i kapacitet baterije, ali i podatke o ponašanju i željama vozača. Ako vozač rijetko i u pravilnim vremenskim razmacima koristi vozilo, moguće su značajne zarade od arbitraže ili pružanja kapaciteta i energije uravnoteženja. Ako pak vozač često i u nepravilnim koracima koristi vozilo tada on mora puniti vozilo gotovo pa neupravljivo kako bi si osigurao potrebnu energiju za vožnju.

Ova doktorska disertacija bavi se s tri izazova povezana s pametnim punjenjem i pružanjem te pružanjem usluga uravnoteženja iz električnih vozila: fizički utjecaj na elektroenergetski sustav, adekvatan i poticajan koncept e-mobilnosti te razvoj strategije za tržišno pozicioniranje električnih vozila.

Prvi izazov jest ispitati kako različite strategije punjenja i pražnjenja električnih vozila utječu na pogon elektroenergetskog sustava s različitim omjerima proizvodnih jedinica, različitim udjelima električnih vozila i obnovljivih izvora energije, različitim planovima dekomisije proizvodnih jedinica, različitim politikama za obnovljive izvore energije itd. Kako bi se navedeno moglo ispitati kreiran je cjelobrojni linearni model za kreiranje voznog reda elektrana (engl.

---

„Unit Commitment“) s integriranim električnim vozilima. Testirane su razne strategije punjenja električnih vozila, od neupravljivog, jednosmjernog i dvosmjernog s i bez utjecaja ili pružanja rezervi. Osim sporog punjenja kada su vozila parkirana, ispitane su i brze stanice za punjenje električnih vozila s i bez stacionarnog spremnika energije. Općeniti zaključak jest da neupravljivo punjenje vodi ka većim troškovima, emisijama stakleničkih plinova te rasipanju obnovljive energije (engl. "Renewable energy mitigation") ponajviše jer su u pogon značajnije uključene skupe vršne elektrane (plinske s otvorenim ili zatvorenim ciklusom). Pametno punjenje, osim što smanjuje troškove, emisije stakleničkih plinova i rasipanje obnovljive energije ima i neizravne koristi poput sniženog cikliranja i ravnomjernije proizvodnje električne energije iz konvencionalnih elektrana. Navedeno dovodi do manje degradacije elektrana, odnosno produženog životnog vijeka. Isto tako, zanimljiv rezultat jest da obnovljivi izvori energije (u sustavu bez električnih vozila) mogu preuzeti značajan dio rezerve ako im je to omogućeno. U određenim slučajevima isplativije je odbaciti dio obnovljive energije nego puštati u pogon konvencionalne elektrane. S druge strane, ako je u isto vrijeme omogućeno i pružanje rezervi iz obnovljivih izvora energije i električnih vozila, električna vozila će pružiti gotovo svu rezervu te u isto vrijeme omogućiti minimalno rasipanje energije iz obnovljivih izvora energije. Dobrobiti pružanja fleksibilnosti iz električnih vozila značajno ovise o energetsom miks razmatranog sustava. U čistom termo sustavu (nuklearne, ugljene, plinske elektrane) dobrobiti su vrlo velike, no one se smanjuju ako u sustav dodajemo upravljive elektrane na obnovljive izvore energije poput akumulacijskih hidroelektrana.

Drugi izazov bavi se problematikom definiranja samog koncepta pametne e-mobilnosti. Dva su moguća koncepta: jedan baziran na punionicama električnih vozila, odnosno CS-based (engl. „Charging Stations“) te drugi baziran na samim električnim vozilima, odnosno EV-based. Pitanje je koji od njih ima veći potencijal za pružanje fleksibilnosti elektroenergetskom sustavu? Pojam fleksibilnosti odnosi se na mogućnost promjene radne točke djelatne snage (tehnički izvedivo s zanemarivim troškom) radi pružanja usluga sustavu. Prvi koncept je zastupljen u skoro svim današnjim sustavima pametnog punjenja, i u praksi i u znanstvenoj literaturi. Prema tom konceptu aktivni sudionici elektroenergetskog sustava su stanice za punjenje električnih vozila, dok su električna vozila samo instrument za pružanje fleksibilnosti. Nekoliko je prepreka kod ovog koncepta kada se razmatra fleksibilnost. Najveća među njima jest nemogućnost stanice za punjenje da prati ili upravlja punjenjem/pražnjenjem električnih vozila kada ona nisu na lokaciji te stanice. Budući da stanica ne zna što se s električnim vozilima događa kada nisu parkirana na njezinim punjačima nije u stanju kreirati optimalni dnevni raspored punjenja/pražnjenja ili pružanja usluga uravnoteženja. Pametne punionice nisu u stanju prognozirati pojedinačne potrebe i mogućnosti pružanja fleksibilnosti od strane električnih vozila već samo kumulativne potrebe za energijom vozila koje su spojene na njihove punjače. S druge strane, u konceptu baziranom na električnim vozilima, električna vozila su aktivni sudionici

---

elektroenergetskog sustava, dok su stanice za punjenje samo infrastruktura koja omogućuje interakciju (slično distribucijskim mrežama koje su infrastruktura koja omogućuje prijenos energije do krajnjeg potrošača). Glavna prednost ovog koncepta jest praćenje ponašanja električnih vozila tijekom cijelog dana čime se može točnije procijeniti kada su optimalni vremenski prozori za pružanje usluga te je moguće prilagoditi pružanje različitih usluga na različitim stanicama za punjenje. Drugim riječima, moguće je maksimizirati pružanje fleksibilnosti bez zadiranja u komfor korisnika. Kroz deterministički matematički model dokazana je prednost predloženog sustava baziranog na električnim vozilima naspram konvencionalnog sustava baziranog na punionicama. Prednosti su značajne u danima kada je cijena energije volatilna, dok se njihov utjecaj smanjuje kada je cijena energije kroz dan jednolika.

Zadnji izazov je razvoj algoritma za tržišno pozicioniranje flote električnih vozila za trgovanje energijom te pružanje kapaciteta i energije uravnoteženja. Posebna pozornost stavljena je na modeliranje aktivacije različitih rezervi u takvim algoritmima. Naime, ovo područje nije dovoljno obrađeno u znanstvenoj literaturi, a ključno je za tehnologije s ograničenim energetske kapacitetom kakva su i električna vozila. Aktivacija rezerve (energija uravnoteženja) vrlo je stohastičan parametar o kojem ovisi kada i kolike ponude će se podnositi na tržištima. U ovoj doktorskoj disertaciji razvijeni su stohastički (bazirani na scenarijima) i robusni modeli (bazirani na najgorem slučaju) koji mogu učinkovito uzeti u obzir spomenutu nesigurnost. Oba modela pokazuju superiornost naspram determinističkog modela čiji rezultati mogu dovesti do neizvedivih radnih stanja električnih vozila, do plaćanja za energiju uravnoteženja i penala radi neisporuke rezervi/energije uravnoteženja. Robusni model pokazao se kao bolji izbor za specifičnu primjenu budući da posjeduje bolje karakteristike u pogledu računalne traktabilnosti te veće upravljivosti za zaštitu od rizika.

**Ključne riječi:** Električna vozila, Pomoćne usluge, Rezerve, Energija uravnoteženja, Pametno punjenje

# Contents

- 1. Introduction . . . . . 1**
  - 1.1. Background and Motivation . . . . . 1
  - 1.2. Objective of the Thesis . . . . . 2
  - 1.3. Structure of the Thesis . . . . . 4
  
- 2. Interconnection of the Power and Electric Transportation Systems . . . . . 5**
  - 2.1. Power System Trends . . . . . 5
    - 2.1.1. Electricity Mix – the Rise of Renewables . . . . . 5
    - 2.1.2. Challenges on the Road - the Increasing Need for Flexibility . . . . . 7
    - 2.1.3. From Flexibility to Energy Arbitrage and Markets . . . . . 9
    - 2.1.4. From Flexibility to Balancing Ancillary Services and Markets . . . . . 10
    - 2.1.5. New Flexibility Sources . . . . . 13
  - 2.2. E-mobility Trends . . . . . 14
    - 2.2.1. EVs in Numbers - Exponential Function . . . . . 14
    - 2.2.2. Electric Vehicle Supply Equipment - Following the EV Trends? . . . . . 15
    - 2.2.3. Architecture of E-mobility System . . . . . 17
    - 2.2.4. Power and E-mobility System Intersection - Downsides and Upsides . . . . . 18
    - 2.2.5. EVs as Flexibility Providers – a Myth or a Valid Pathway . . . . . 20
  - 2.3. Connection to the Contributions . . . . . 22
  
- 3. Modeling Framework . . . . . 23**
  - 3.1. Mathematical Programming Models . . . . . 23
    - 3.1.1. Different Types of Models . . . . . 23
    - 3.1.2. Procedures for Solving Linear and Integer Problems . . . . . 25
  - 3.2. Different Types of System/Market Modeling . . . . . 27
    - 3.2.1. US vs EU Electricity Market Modeling . . . . . 28
    - 3.2.2. Price Taker vs Price Maker . . . . . 29
    - 3.2.3. Uncertainty in Optimization . . . . . 30
    - 3.2.4. Static or Multi-stage Problems . . . . . 30

3.3.	Incorporating Uncertainty Within Bidding Strategy . . . . .	31
3.3.1.	Scenario-based Stochastic Programming . . . . .	31
3.3.2.	Robust Programming . . . . .	33
3.3.3.	Other Methods . . . . .	34
3.4.	Models Used in This Thesis . . . . .	36
<b>4.</b>	<b>Main Scientific Contributions . . . . .</b>	<b>37</b>
4.1.	Model for Optimal Charging Scheduling of a Fleet of Electric Vehicles . . . . .	37
4.2.	Methodology for Evaluating Benefits of Different Charging Strategies . . . . .	38
4.3.	Strategic Positioning Model for Electric Vehicle Aggregator . . . . .	39
<b>5.</b>	<b>List of Publications . . . . .</b>	<b>41</b>
<b>6.</b>	<b>Author's Contribution to the Publications . . . . .</b>	<b>45</b>
<b>7.</b>	<b>Conclusions and Future Work . . . . .</b>	<b>49</b>
7.1.	The Main Conclusions of the Thesis . . . . .	49
7.2.	Further Research Directions . . . . .	50
<b>Bibliography</b>	. . . . .	<b>51</b>
<b>Abbreviation</b>	. . . . .	<b>60</b>
<b>Publications</b>	. . . . .	<b>63</b>
Journal Papers	. . . . .	63
Conference Papers	. . . . .	141
<b>Biography</b>	. . . . .	<b>202</b>
<b>Životopis</b>	. . . . .	<b>207</b>

# Chapter 1

## Introduction

Decarbonisation of the global economy follows the combined efforts of the governments worldwide to reduce the pressure on the planet's rising global temperature. Decarbonisation refers to the process of transition from the fossil-fuel-driven economy to the non-polluting or renewable resources. The key of this process is to decrease the greenhouse gas emissions (GHG) wherever and as much as possible. The research presented in this thesis deals with the interaction of the decarbonisation processes in two sectors: power systems – renewable energy sources integration and transport system – road vehicle electrification. The main focus is on use of smart electric vehicle charging (decarbonized transport infrastructure) to provide reserves and balancing services to the decarbonised power system.

### 1.1 Background and Motivation

According to [1], energy consumption is undoubtedly the biggest source of human-caused GHG emissions, responsible for 73% of the emissions worldwide. It is followed by agriculture (12%), land-use and forestry (6.5 %), industrial processes (5.6%) and waste (3.2%). The cited data refers to the year 2016 as it is the last year with complete data sets. Within the sector of energy consumption, generation of heat and electricity takes the highest share in GHG emissions with 30% of the total emissions (of which 70% is from coal power plants). Transportation sector occupies the second place with 15% and is closely followed by the manufacturing and construction with 12% of the total GHG emissions. If the analysis proceeds towards the last step, i.e. towards end-use activities, it can be seen that the road transport (11.9% of total) is the highest GHG emitter followed by energy consumption in residential (10.9% of total emissions) and commercial (6.6% of total emissions) buildings. Those percentages include both direct emissions from fossil fuel combustion and indirect emissions such as electricity and heat use.

Industrial processes, heat and electricity (part of energy sector), transportation (part of energy sector), manufacturing and construction (part of energy sector) are the sectors with the



highest rise in GHG emissions; with the reference year of 1990 and target year of 2016 the percentages of the increase are the following: 174%, 76%, 71%, 55% [1]. Increase in industrial processes is predominantly stemming from increase in the refrigeration, whereas the energy-related emissions in the heat and electricity, transportation, manufacturing and construction are emerging as an affect of increase in the electricity and heat end-use, road vehicle traveling and industrial production, respectively. The increase in heat and electricity related emission where positive until 2013 (1990-2013: 78%) and afterwards sunk by 2% in the 2013-2016 period. The decrease can be interpreted as an effect of the decarbonisation measures such as the transition from coal to gas power plants and to renewable energy sources. However, some of the more recent data shows further increase of heat and electricity related emissions. It could be labeled to the following effect: event though the decarbonisation measures are in place (in many but not all countries) the rise in the heat and electricity demand worldwide is still sufficient to continue supporting fossil fueled power plants.

It is clear that the decarbonisation process must proceed and even intensify if we want to reach sufficient sustainability levels. The two sectors with the highest absolute emission rates as well as the highest relative increase, in reference to 1990, are the power systems and road transport systems. They are the ones which should be decarbonized first as they have the highest impact. Zero-carbon solutions are becoming competitive across different economic sectors but the trend is the most noticeable in exactly those two sectors as they created many new business opportunities for early movers. In a nutshell, decarbonisation in the power system mainly refers to the process where fossil fueled generation is gradually replaced with renewable energy sources (RES, predominantly wind and solar power plants) and fossil fueled internal combustion engine (ICE) vehicles are replaced with alternate fuel vehicles (predominantly electric vehicles – EVs).

## 1.2 Objective of the Thesis

At a first glance, the new design of the power and transport systems with new zero-carbon technology seems flawless. However, there are integration challenges that must be solved as the penetration of either of them increases. When considering RES, their variable and unpredictable nature increases the overall variability and uncertainty in the power system. Along with the decommission of the fossil fuel power plants it creates the lack of flexibility (controllability) in the power system operation and can create balancing and grid issues. If not strategically managed, it can happen that the decarbonisation measures in the form of RES power plant integration lead to new requests for flexible carbon units such as gas (fossil fuel) power plants which is contradictory to the primary intention of the measures. To bridge the gap between carbon driven and carbon-free power system, new carbon-free flexibility providers should be

introduced.

Road transport electrification brings its own challenges as well. The first phase was electrification under a passive/dumb/uncontrollable approach where the EVs charge at full power right from the beginning of the charging process until fully charged. They do not take into account electricity system and grid constraints whatsoever. Such charging can lead to grid issues such as congestion or under/over voltages. The issue is mostly related to the distribution network, where EV chargers are located, but similar effects can appear in the transmission network. Passive EV charging can also alter the demand curve and introduce new variability and unpredictability to the demand side, which reflects to the power system balancing. Once again, if decarbonisation is managed poorly, the road transport electrification can lead to increased needs for flexible carbon power plants which only transfers the emissions from one sector to another. If overall economy is observed, this nullifies the desired effect of the measures. And once again, to bridge the gap between the carbon-driven and the carbon-free transport system, new carbon-free flexibility providers should be introduced.

To summarize, decarbonisation measures in both the power and the transport sectors have two prominent downsides: power grid and balancing issues. Solutions for both of them can be versatile, e.g. investment in new technology (stationary batteries), changes in the grid operation concept (active grids, microgrids), activation of demand (demand response), liberalization of services (congestion and balancing markets), smart charging of EVs, etc. The focus of this thesis is on use of one of the possible solutions, EVs as active system/market participants, to solve the balancing issues. In the proposed approach, the EVs are not charged passively, which is the practice today, but they are seen as a fully flexible source under bidirectional smart charging scheme that helps the power system and EV users as follows:

- the EV charging is more predictable (as opposed to today's business-as-usual charging) and therefore it does not create new balancing issues – consequently, it does not create additional costs to the electricity users which would, in turn, manifest as higher charging costs for the EV users;
- the EV charging process is controllable and it can charge when there is an abundance of the RES generated power or discharge when the RES power is scarce – it directly translates to charging when the prices are low and discharging when the prices are high and the overall lower charging bills for the EV users;
- the EV charging is more controllable and can provide balancing services to the power system operator to resolve the balancing issues created by the RES integration – less balancing issues means lower charging cost and balancing services provision means additional revenues for the EV users.

The scientific contribution of this thesis consists of the following:

1. Model for optimal charging scheduling of a fleet of electric vehicles with the goal of

- providing reserve services and increasing overall power system flexibility;
- 2. Defining methodology for evaluating benefits of different charging strategies of a fleet of electric vehicles with the goal of increasing the share of variable renewable energy penetration;
- 3. Strategic positioning model for electric vehicle aggregator on electricity and ancillary service markets.

### **1.3 Structure of the Thesis**

The thesis is structured as follows:

- Chapter 2 reviews current processes and status of both systems of interest: power systems and e-mobility (road transport) system;
- Chapter 3 defines and elaborates the mathematical methods often used in the power system modeling which are utilized in this paper;
- Chapter 4 elaborates on the main contributions of the paper and links them to the publications;
- Chapter 5 presents the list of all relevant publications,
- Chapter 6 summarizes author's contribution to the publications;
- Chapter 7 concludes the thesis and highlights main findings.

# Chapter 2

## Interconnection of the Power and Electric Transportation Systems

Power and road transport system share the same long-term goal of zero-emission operation. However, the path to reaching the final goal is complex and thorny, where deep integration of emission-neutral technologies require conceptual changes to the business-as-usual for both observed systems. This Chapter will provide an introduction to the current status and future trends in the power and e-mobility systems and position the research conducted throughout this thesis within those two systems.

### 2.1 Power System Trends

The power system is experiencing a process of transition toward a green-energy system. In the following subsections this transition will be elaborated from the perspective of the current and the future electricity mix, flexibility challenges and market solutions for system-wide services – energy arbitrage and reserves provision. Finally, the section will boil down to the potential and necessity of using e-mobility as the next-era flexibility provider.

#### 2.1.1 Electricity Mix – the Rise of Renewables

The current total energy mix in the world is still largely based on fossil fuels and according to [2] and [3] for 2019. it is as follows: oil - 33.1 %, coal - 27%, gas - 24.2%, nuclear - 4.3%, hydropower - 6.4%, - wind 2.2%, - solar 1.1%, biofuels - 0.7% and other renewables 0.9%. In total, more than 84 % of the world energy comes form fossil fuels. Renewables take only 11.4% of the total energy consumption. Observing only electricity, the mix is a bit different [2]: oil - 3.1%, coal - 36.7%, gas - 23.5%, nuclear - 10.4%, hydropower - 15.8%, wind - 5.3%, solar - 2.7%, other renewables - 2.5%. More than one third of electricity comes

from the low carbon technologies (nuclear + RES), and more than one fourth comes from RES. The situation is better than in total energy mix meaning that power systems are pioneering sector when it comes to decarbonisation, but still the largest share of electricity generation fleet is fossil fueled. Even though the renewable sources (observing all types: hydro, wind, solar, bio...) experienced the highest relative rise in the electricity generation in the last two decades (1999. 2.87 GWh - 2019. 7.03 GWh  $\approx$  2.5 times increase), the total energy demand increased substantially in absolute terms (1999. 14.81 GWh - 2019 26.77 GWh  $\approx$  1.8 times increase) which entailed high investments in new fossil fueled units of all types, but primarily coal and gas (1999 8.21 GWh - 2019 16.12 GWh  $\approx$  2 times increase) [4]. There is large discrepancy between developed countries (US, EU etc.) where the total increase in electricity consumption is low with fast RES integration policies and developing countries (China, India etc.) whose total electricity consumption is rapidly increasing [5] but the RES integration pace cannot follow it. The former countries are already experiencing the RES integration challenges, whereas in the latter countries they are yet to come.

If the focus is switched on one of the leading countries in RES integration, e.g. Germany, it can be seen that their historic curves are different than global trends [2], [4]. Coal is sharply decreasing (1999. 279.1 TWh - 2019 171.2 TWh  $\approx$  1.6 times decrease), hydropower is stagnating (1999. 20.69 TWh - 2019 20.19 TWh), while gas (1999 51.8 TWh - 91.0 TWh  $\approx$  1.6 times increase) and RES without hydro (1999 9.14 TWh - 2019 224.1 TWh  $\approx$  24.5 times increase) are increasing. Such developments lead to the extremely high shares of RES generation compared to not-RES generation (fossil plus nuclear) in Germany [6] in 2019 (RES - 46.1%, not-RES 53.9%) and 2020 (RES - 50.6%, not-RES 49.4%). The 2020. was the first year in history with RES generation higher than not-RES, in February 2020. the RES generation was more than 60% of total generation.

According to IEA Global Energy Outlook [5] the power systems are being reshaped by technology development and by energy security and sustainability goals, and this decarbonisation process will continue in the future. In 2019, RES and nuclear generated more electricity than coal. Following the Stated Policies Scenario from [5] (STEPS - future scenarios based on today's policy settings and an assumption that the COVID pandemic is brought under control in 2021). By 2030, RES and nuclear power will provide nearly half of global electricity supply in the STEPS. RES electricity generation will overtake the coal as primary means of generation by 2025 where solar and wind are the leading technology. It is worth mentioning that 166 countries now have targets for RES in power systems. Gas is environmentally less harmful than coal and its generation will increase by 30% by 2040 (increase in period 2019-2040  $\approx$  2 GWh) providing the backup for the RES integration. The RES alone will provide nearly 40% of electricity supply by 2030. Solar becomes the fastest growing technology with increase of around 660% (increase in period 2019-2040  $\approx$  4.8 GWh) followed by wind with increase of around 280% (in-

crease in period 2019-2040  $\approx$  4.0 GWh) compared to 2019 generation levels. Hydropower have moderate increase (increase in period 2019-2040  $\approx$  1.6 GWh) since locations for large plants are becoming scarce, whereas bioenergy and nuclear energy have much lower effect compared to solar and wind, 0.74 and 0.65 GWh increase in period 2019-2040, respectively. Due to this reasons, the term RES in the following Sections refers to wind and solar if not explicitly stated otherwise.

As a conclusion, the power system decarbonisation/RES integration trends will continue and intensify in the future worldwide and power system researchers and engineers must adapt the system planning and operation methods to them if necessary to at least keep the current security of supply levels.

### 2.1.2 Challenges on the Road - the Increasing Need for Flexibility

Traditionally, the main flexibility sinks are demand uncertainty and variability plus generation fleet and grid infrastructure failures. The term *flexibility* refers to the ability of the unit to change its parameters, primarily active power generation output (technically viable with negligible economic loss). The flexibility is usually bidirectionally divided where terms up or positive flexibility refer to increased power injections or decreased power extractions and terms down or negative flexibility refer to decreased power injections or increased power extractions (compared to planned schedules). In the similar manner, one can say that the power system is flexible if it has sufficient amount of flexible units to wrestle against the overall system's variability and unpredictability and therefore can maintain continuous power supply [7], [8]. The flexibility is wide term which covers a variety of services spanning time scales measured in seconds to hours, days and across seasons. It could be seen as services connected to electricity markets (arbitrage), system adequacy (capacity remuneration mechanisms), transmission and distribution grids (congestion and voltage management, investment deferral), "behind-the-meter" (grid tariff management, peak shaving), balancing balance responsible parties (providing balancing energy), system balancing (providing virtual inertia, reserves, balancing energy) etc. In this thesis the focus is on the first and last group of services whilst the rest of the services falls out of the scope. The energy trading on markets is used as a base to investigate the system balancing challenges and therefore the term flexibility in the rest of the paper means either *market flexibility* or *balancing flexibility*.

New RES enhance the need for new flexibility sources in a twofold manner: they decrease offer and increase demand. Flexibility offer decrease – indirectly RES drive the conventional flexibility providers into unprofitable business operations (lower wholesale prices, shorter peak price periods...) and eventually to their decommissioning. Conventional flexibility providers are large centralized fossil fueled and hydro power plants. Flexibility demand increase – additional variability and unpredictability brought by RES to the power system directly increase flexibility

requirements [9].

The power output of RES power plants is not flexible compared to the fossil fuel power plants. The fossil fuel plants can store their primary energy source (coal, oil, gas...) and generate power on request. If they decide not to generate power, energy is not lost but stored for the latter use. However, if the RES power plant decides not to produce power that energy will be lost (often referred to as *RES curtailment*). Another issue is that the RES can generate power as much as the primary resource allows, e.g. if the wind is blowing with the speed which is less than maximal projected, wind power plant will not be able generate its full rated power. The capacity factors for wind are around 30% whilst for solar are around 20% [10]. The economically optimal power generation of the RES power plants is connected to the current weather conditions and forecasts. This brings us to the challenge of RES behaviour and forecasting or to the challenge of RES variability and uncertainty. The RES generation changes as the weather conditions change (variability), from zero to full rated power in matter of minutes. The RES forecasts are not perfect and always contain some level of errors [8]. Those errors mean that RES generation is uncertain and should have backup generation if weather conditions diverge from the forecasted ones. It's worth mentioning that the vast majority of RES units is coupled to the system through power electronics – invertors. They technically can be easily programmed to provide flexibility, but with financial losses mostly due to RES curtailments. If the RES unit desires to provide up flexibility it should schedule their generation bellow maximal forecasted generation to be able to ramp up the generation on request (price or balancing signal). If the RES unit desires to provide down flexibility they schedule their operation on maximal forecasted generation but if the flexibility is requested they will be ramped down bellow maximal forecasts. In both cases the RES curtailment will occur. Additionally, weather uncertainty could pose a risk of inability of provision of promised flexibility for RES units as the real generation could differ from the maximal forecasts.

Flexibility on energy markets can be defined as the possibility to adapt to the wholesale electricity price signals. For the producers, it means to sell when the price is high and for the consumers it means to buy when the price is low. RES units cannot choose when to generate/sell without noticeable RES curtailment. On the other hand, fossil and hydro power plants can easily choose not to sell if the price is lower than their marginal generation cost. Similarly as RES, conventional demand facilities cannot choose when to consume/buy electricity as it will harm users comfort or the efficiency of the processes. Development towards demand response consumers is explained in Section 2.1.5. Traders and energy storage facilities can exploit the variable character of electricity price even more through energy/electricity arbitrage. This process entails buying/charging electricity when cheap and selling/discharging when expensive. The main parameters to handle arbitrage is what are the losses in the buying/selling process and how big is the difference between low and high prices.

The power systems rely on the equilibrium of system-wide power generation and consumption. If this balance is disturbed the system frequency deviate from the rated one (50 Hz in Europe) which is not allowed as it yields negative effects to the users and their electrical equipment. In the fossil fueled power system the generation side always followed demand and kept the frequency deviation as low as possible. This, in general, means that fossil fueled power plants (along with large conventional hydro power plants) provided most of the necessary balancing flexibility to the power system. If there is no fossil fueled generation (high penetration of RES) the power system losses most of its balancing flexibility and cannot keep the same level of frequency deviations. New flexibility sources should be introduced to support the balancing needs of low carbon power system as highlighted in 2.1.5. Power systems with high share of hydropower rely on hydro generators as balancing flexibility providers and they are less affected by the increasing share of RES.

Sections 2.1.1 and 2.1.2 clearly point out that developments in the traditional flexibility services concepts are necessary to support further decarbonisation process. Diversification of the flexibility providers is essential, but to achieve it a prerequisite is to have adequately and transparently defined flexibility services and their markets.

### **2.1.3 From Flexibility to Energy Arbitrage and Markets**

Flexibility can be provided to different system entities from electricity markets, system operators to balance responsible parties and end-users. The last two entities are the private ones, whereas the emphasis of this research is on the system-wide services. Note that Chapter 4 explains how easily the concepts and the models can be adapted for other services as well.

As stated in Section 2.1.2, flexible market participants can adapt to the prices stemming from the wholesale electricity markets. The wholesale electricity markets are the arenas for the bulk electricity trade by the pure energy price (no grid tariffs, governments levies and taxes etc.). They can be divided to long-term and short-term markets. The long-term markets are usually financial contracts traded several years to weeks ahead of the delivery used for hedging the risk of short-term uncertainties. Short-term markets are closer to real-time and they are mostly physical contracts with agreed electricity delivery (agreed delivery period, price and volume). Both of the mentioned markets can be traded bilaterally and on organized exchanges. This thesis focuses on organized short-term markets as they provide transparent conditions and price and form the foundation for all other trading possibilities (for example reference price for bilateral and long-term contracts).

Globally, many different organized short-term market concepts exist. The leading two being the North American ISO/RTO power pools and EU power exchanges. The former ones are characterized with centralized dispatch where the producers submit their technical data and marginal cost and the market algorithm schedules the cheapest ones to satisfy net demand (demand - vari-



able RES generation). The ISO/RTO dispatch the producers according to the algorithm directly. Since the system operators are the organisers of these markets, they often co-optimize the reserves with the energy as well. In the EU, power exchanges are separated from the TSOs and market algorithm takes the buyers offers and sellers bids (the same conditions apply for all participants, i.e. the markets are technology neutral), creates the aggregated buy and sell curves, and the price settles on the intersection of the two curves. Afterwards, all the buyers and sellers self dispatch themselves according to the accepted offers and bids, respectively. These accepted offers and bids act as a planned schedule which is submitted to the TSOs and which is used as a reference when calculating participant's imbalances (more detail in Section 2.1.4). As the TSO's are separated from the electricity markets, they organize independent markets for the ancillary services such as reserves (more detail in Section 2.1.4). The rest of the thesis concentrate on EU style markets [11].

In Europe, power exchanges organize several type of markets [11]: Day-ahead (DA) auction, Intraday auction, Intraday (ID) continuous trading. The paper focuses on DA market as it is the cornerstone market with 24 hour trading horizon and half to quarter hourly resolution. The gate closure is 12 hours ahead of the first delivery period. Intraday markets supplemental markets to the DA market where market participants try to balance themselves before delivery.

European markets started as national markets but they are in the process of coupling with the aim of creation of one integrated EU market as regulated in [12]. The markets are also continuously developing in the direction of shorter gate closure times, smaller volumes and shorter trading resolution to adapted more to new technology such as RES and new flexibility providers elaborated in Section 2.1.5. Apart from system operation (Section 2.1.2) and energy markets 2.1.3 the important aspects for the further decarbonization are the balancing services and markets further processed in the Section 2.1.4.

### **2.1.4 From Flexibility to Balancing Ancillary Services and Markets**

The services through which the flexibility is provided to the transmission (TSO)/distribution system operators (DSO) are usually termed *ancillary services*. The role of ancillary services is to keep the system stable and running continuously. The in-effect EU electricity market directive [13] defines ancillary service as: "a service necessary for the operation of a transmission or distribution system, including balancing and non-frequency ancillary services, but not including congestion management". As mentioned in Section 2.1.2, the focus in this thesis is on the balancing ancillary services which are defined in [14] as: " all actions and processes, in all time-lines, through which transmission system operators ensure, in an ongoing manner, maintenance of the system frequency within a predefined stability range and compliance with the amount of reserves needed with respect to the required quality."

In general, the European power systems are balanced though balance responsibility and re-

serve activation/balancing energy provision mechanisms. The former one states that each market participant is responsible for their own imbalances (discrepancies between planned power schedules and real power realizations). As defined in [14], each participant will be a balance responsible party (BRP) or it will delegate its balance responsibility to another BRP. Each BRP will be penalized by the TSO for their imbalances according to valid imbalance settlement price (ISP). ISP provides financial signals for the participants to decide whether to invest more into new forecasting, measurement and control technology or to continue to remunerate the TSO for their imbalances. The ISP is published ex post after the actual power delivery and it is based on the reserve activation prices for that balancing period.

The reserve activation/balancing energy provision mechanisms are the other side of the balancing efforts. If the BRPs do not preserve the balance between the planned schedules (from the day-ahead) and real-time realizations the system will suffer from the system-wide imbalances. To bring back the balance the TSOs use balancing energy from the reserve or balancing service providers (BSP). In other words, ancillary services used to solve balancing issues can be divided into reserves and direct balancing energy (often referred to as *voluntary bids* in the market context). Reserves are flexible power capacities allocated before the actual delivery of the services (year, month, week, day-ahead) which can be, if needed, activated to provide balancing energy. Balancing energy can be provided through mentioned reserve activation or by direct energy trading within the delivery period in close to real-time. The latter way doesn't entail any kind of prior capacity reservation. The reserves are design to ensure that sufficient balancing energy will be on disposal in the real time to the TSOs. The direct balancing energy provision is designed in a way that all the unused flexible capacities in the real-time can still provide balancing services to the TSOs to widen their possibilities and to lower the price.

Different market arrangements for reserves and balancing energy currently exist in Europe [15], [16], [11]. The Nordic countries and France operate separate auctions for reserves and balancing energy. The reserve auctions are organised year to day ahead of the delivery and the BSPs bid only reserve capacity volume-price pairs where the cheapest ones get accepted until the required amount of reserves is reached. Afterwards, closer to real-time, the balancing energy auctions are operated where all those accepted for reserve provision are obliged to submit bids for balancing energy (volume-price pairs) up to their accepted reserve volume. Additionally, all other BSPs can voluntary bid their unused capacities as direct trading of balancing energy. The cheapest ones are accepted up to the required amount of balancing energy in the real-time. In Germany, the BSP bid at the same time the reserve capacity volume-price pairs coupled with balancing energy volume-price pairs. The first stage in the auction is arranging the capacity volume-price pairs in an ascending order by price, where all bids up to the total required volume are accepted. The second stage of the auction process arrange the energy volume-price pairs in an ascending order by price and all the bids up to total required energy are activated. Direct

trading of balancing energy or voluntary bids are not allowed. Some EU countries still lack the legislative and regulative support to issue adequate markets and still have monopolistic and bilateral arrangements for the reserve and balancing energy trading. The EU is therefore pushing the harmonization rules [17] to create the cornerstone for future integrated transnational market for reserve capacity and balancing energy [15], [11]. The goal of such efforts is to increase the international trade of those services, lower their price and increase the utilization of the interconnecting lines. For the reserve providers it is important that they are paid twofold: for the promised/reserved capacity in EUR/MW/(balancing time period) and for the actual activated balancing energy in EUR/MWh. The BSP directly selling the balancing energy can acquire only the second fee.

In Europe, the harmonization rules [18] defined four main categories of reserves (more about reserves in [19], [20]):

1. Frequency Contentment Reserves (FCR):

- the active power reserves available to contain system frequency after the occurrence of an imbalance;
- first line of defence, activates automatically on frequency deviations;
- operating reserves with the activation time up to 30 seconds;

2. automatic Frequency Restoration Reserves (aFRR):

- the automatically activated active power reserves available to restore system frequency to the nominal frequency and, for a synchronous area consisting of more than one LFC area, to restore power balance to the scheduled value;
- second line of defence, activates automatically on area control error (ACE) signal;
- an activation time with a delay of 30 seconds up to 15 minutes;

3. manual Frequency Restoration Reserves (mFRR):

- the manually activated active power reserves available to restore system frequency to the nominal frequency and, for a synchronous area consisting of more than one LFC area, to restore power balance to the scheduled value;
- third line of defence, activates manually by TSO's dispatch center;
- an activation time with maximum of 15 minutes;

4. Replacement Reserves (RR):

- the active power reserves available to restore or support the required level of FRR to be prepared for additional system imbalances, including generation reserves;
- fourth line of defence, activates manually by TSO's dispatch center;
- an activation time with minimum of 15 minutes;

### 2.1.5 New Flexibility Sources

Whether it is about market or balancing flexibility, one thing is sure, the direction toward green power system means loss of conventional flexibility providers and increasing flexibility requirements (more details in 2.1.2). The question that arises is: who will compensate the missing flexibility? The question can be reformulated to: which technology will bridge the flexibility gap?

There are several approaches to solve the flexibility riddle, some of them are listed here [8], [9], [7], [21]:

1. Grid-related solutions - enabling sufficient flexibility provision:
  - conventional grid extension – building new lines (especially interconnections) to ease and enhance energy and flexibility flow;
  - grid activation – integration of measurements, FACTS and remote control devices into the grid thus enabling directed power flows and dynamic topology changes;
  - microgrids and energy communities – allowing privately owned medium and low-voltage networks to group and jointly manage their energy needs. With the ability of island operation and the goal of selfsupply;
  - reformulation of grid codes – enabling flexibility provision of end-users.
2. Market-related solutions - enabling sufficient flexibility provision:
  - existing markets redesign – adjusting the market products to aggregators, storage systems, distributed energy sources (DER) and RES;
  - new markets incorporation – creating markets for virtual inertia, congestions, voltage management etc.;
  - market coupling – integrating adjacent energy, reserve capacity, balancing energy markets to allow energy and flexibility flow from areas with lower price to areas with higher price;
3. User-related solutions - providing flexibility:
  - further development of RES flexibility provision concepts – RES energy curtailment or "behind-the-meter" storage integration;
  - further development of demand response concepts – integration of IoT technology to enable loads to adjust to power system needs, users behavior change to allow demand response;
  - further integration of energy storage solutions – household, buildings, industry, utility-scale, RES facility storage integration;
  - enabling smart EV charging and discharging – maximal utilization of smart e-mobility by complete integration into power system operation;

The combined effect of the above-listed solutions is probably the correct pathway for sustainable future. Grid and market-related solutions are the prerequisite for sufficient provision of

flexibility from the user side. The smart e-mobility imposes as one of the leading sustainability ingredients. There are several reasons which backup this statement. E-mobility is pushed forward not from the power system side but from the road transportation side. Meaning that most of the investment into the e-mobility is not related to the power system, hence the transport electrification and its' smartening doesn't cost much from the power system point of view. It can be compared with demand response and its enabling technology (ICT, metering, control...) which can cost significant amount of investment relative to the financial gains of demand response [22]. Part of the cost can be justified as the means of allowing the users to gain better insight into their consumption processes. The costs are especially critical with energy storage integration as they are the technology whose sole purpose is the flexibility provision and all the cost must be reimbursed through financial gains of flexibility provision. It is interesting to observe that smart e-mobility can be seen as both demand response and energy storage. If EV charging is shifted in time it acts as demand response, but if EV is discharged back to the grid it act as a battery storage. In Section 2.2 the smart e-mobility and its intersection with power systems will be further analyses and elaborated.

## **2.2 E-mobility Trends**

Historically, the predominant energy source in transport sector is oil providing 92% of transport energy need in the past decade (0.8% is electricity). Increased transport needs directly translated to increased energy consumption in transport sector which is around 30% of total global energy consumption [5] and to 15% of total GHG emissions [1]. These factors led to accelerated switching to alternate fuels in transport sector. Coupled to power system decarbonisation, transport sector electrification is key technology to reduce GHG emission and air pollution. Electric vehicles have zero tailpipe emissions (if supplied by renewable electricity) and better efficiency compared to ICE vehicles. This Section will investigate the trends in e-mobility sector 2.2.1 and connect it with power system operation 2.2.4.

### **2.2.1 EVs in Numbers - Exponential Function**

In 2010 there were only 17 thousand EVs on the roads worldwide. The accelerate electrification in the next decade led to about 17.2 million EVs in 2019. Over the last five years the annual EV increase was 60%, whereas increase in 2019 compared to 2018 there was around 40%. The electrification is concentrated to China, Europe and United States (47%, 25% and 20% of the global EV fleet in 2019, respectively). Norway is leading the way with 13% of its fleet already electrified, followed by Iceland with 4.4%, Netherlands with 2.7%, Sweden with 2.0% and China with 1.6%.

Even though the annual growth slows, the market share increases. In 2019, more than 20 countries have reached 1% market share of EVs in total number of vehicles sold [23]. The EV's market share worldwide in 2019 was 2.6% (total number of new EVs was 2.1 million) whereas in 2018 and 2017 it was 2.4% and 1.5%, respectively. China was the largest market for EVs with more than 50% of new sales (1.06 million) followed by Europe and US with 541 and 327 thousands, respectively. The total market share in China was 4.9%, while in Europe it was 3.5%. In Europe, the Norway had highest EV market share of 56% of total vehicles sold. The Germany had the biggest volume of sold EVs of 109 thousand EVs. The France, Netherlands and UK had more than 50 thousand EVs sold in 2019.

The lower annual increase in 2019-2018 (40%) compared to 2018-2017 (60%) was mostly due to three factors: decreased overall passenger car sales, cuts in purchase subsidies (many countries are starting to see EVs on level playing field to ICE) and customer expectations of new technology (many new EV types are announced as well anticipated cost decrease and longer travel distances) [23]. The COVID pandemic in 2020 created unprecedented drop in all car type sales due to lockdown policies. However, the authors of [23] expect that the EV market will be less influenced by the pandemic than ICE market. The overall vehicle market revival will be strongly influenced with government policies as the vehicle manufacturing industry is important economic driver in many developed countries.

The future EV stock number predictions be found in [23] under the Stated Policies Scenario from [5] (STEPS - future scenarios based on today's policy settings and an assumption that the COVID pandemic is brought under control in 2021) and Sustainable Developed Scenario (SDS - future scenarios with decarbonisation meet the Paris Agreement goals). IN STEPS scenario the global EV stock will go from 8 million in 2019., through 50 million in 2025 (with 14 million sales in 2025 alone - 10% share of total vehicle sales) up to 140 million by 2030 (with 25 million sales in 2030 alone - 16% share of total vehicle sales). It is expected that EVs will account for 7% of global vehicle fleet by 2030. The SDS scenario is far more ambitious forecasting that global EV stock will reach 80 million EVs in 2025 and 245 million EVs in 2030. In both scenarios China retains the lead in absolute numbers of EV deployment. In STEPS, China reach almost 35% not considering two wheelers and 60% across all EV types of EV market share in 2030. Europe closely follows China trends and reaches market shares of more than 30% across all EV types.

### **2.2.2 Electric Vehicle Supply Equipment - Following the EV Trends?**

Development of electric vehicle supply equipment (EVSE, charging infrastructure, chargers) alongside building up and EV fleet is often considered as chicken and egg dilemma as investment in one is a prerequisite to the development of the other. Future EVSE needs are depending on the mutual relationship of EV stock, driving requirements, routing, EVSE technical capa-

bilities etc. The governments are therefore forced to stimulate investment in both of them to create a complete e-mobility system. EVSE could be private where users must have specific permission to charge (home, workplace etc) or public which are open to all users (next to commercial buildings, on parking lots, dedicated fast charging stations etc.). The home charging access is positively correlated with the number of EV users living in family houses or units with the private garages [23]. Workplace charging depends heavily on company initiatives or local policies, whereas public chargers have higher shares in large and dense cities, especially in China. Another classification of EVSE is by their installed power which range from several kilowatts to more than hundred kilowatts. In [23], authors separate three main EVSE groups: private (home and workplace), public slow and public fast. The average private EVSE installed power is assumed to double from today's 3.3 kW to 6.7 kW in 2030. Average slow charging power is assumed to be 7.4 kW whereas average fast charging power would reach 150 kW in 2030 (based on historic growth of DC EVSE).

The number of private chargers for all the types of road vehicles expands from 6.4 mill. in 2019 to 135 mill. in 2030. From the energy and power perspective, those chargers would be responsible for consumption of around 400 TWh from 0.6 TW of installed power in STEPS scenario. In SDS scenario, number-wise, energy-wise and power-wise are expected to reach 240 mill., 770 TWh and 1.1 TW, respectively (approximately double than STEPS).

The public charging infrastructure role can be twofold: as a complementary to private charging in less dense and less urban areas and as a primary charging source in highly dense and urban areas. The home charging is assumed to be primary source (the cheapest and the least intrusive to power system) accompanied with workplace charging (next step in affordability and intrusiveness). Less dense areas have more space for private chargers (both home and workplace) and therefore can utilize it more. In this case, the public chargers are mostly used to supplement private EVSE and to lower range anxiety (fear of insufficient range). However, dense areas are designed with more skyscraper alike buildings without private parking places (both home and workplace). Vehicle users are mostly parking in public places and therefore they would charge more on slow public EVSE. The fast public EVSE is still used to supplement insufficient charging capabilities on those chargers. In 2019 there were around 870 thousand publicly available slow and fast chargers, while the SPEPS predicts its increase to 11 mill. with energy consumption of 70 TWh and installed capacity of 0.12 TW. SDS predicts two times more than STEPS in 2030, number-wise, energy-wise and power-wise public EVSE to reach 20 mill., 120 TWh and 0.2 TW. If STEPS numbers for slow and fast public charging are to be compared, it can be concluded that 90% of EVSE will be in slow chargers with 60% of installed power and 20% of consumed energy.

### 2.2.3 Architecture of E-mobility System

E-mobility system depends on several players which must be adequately orchestrated to jointly deliver the charging service [24], [25], [26], [27]:

- Charging point related:
  - Charging point manufacturers, sellers, installers
  - Charging point owners
  - Charging point (/station) operators
- E-mobility service related:
  - E-mobility (service) providers
  - E-mobility roaming platforms
- Power system related:
  - Electricity suppliers
  - Grid operators (DSOs and TSOs)
  - Aggregators
- EV related:
  - EV manufactures, sellers
  - EV owners
  - EV users

The first group of players is connected with the EVSE, or the charging points. First, the EVSE must be manufactured, distributed, sold and installed at the charging point owners premises. These actions are outside-the-scope of everyday e-mobility operation, but are important to mention in general classification.

The charging point owner (local authorities, commercial businesses, public institutions etc.) buy and pay for the installation of the EVSE on their own premises. With those charging points, they can earn from the provision of the charging infrastructure by direct payments (public) or indirectly benefit from the increased comfort of their users (private). The owners do not need to be involved into technical operation of the charging points and often the operation of the charging points is outsourced to dedicated companies - Charging Point Operators or CPOs (often the same companies which sell the EVSE). However, in the case of dedicated fast charging stations those roles are sometimes merged.

CPOs are the companies operating and maintaining a pool of charging points from different owners. CPOs can have the option for direct provision of charging service to the EV users and by doing so they also take the role of the E-Mobility Providers or EMPs. However, these services are usually provided by separate EMP entities which have the contracts to multiple charging points (of different CPOs). On the other side, the EMPs have contracts with multiple EV users. The EMPs are the bridge between many different CPOs and EV users. In general, EMPs provide charging services to EV users by enabling them access to the charging points



(authentication) and by offering payment options. There is also one step above the EMPs in the case of e-mobility roaming platforms which serve as a bridge between several EMP companies. For example, if a two EMP companies work in two adjacent countries they can allow roaming charging when EVs transit from one to another country.

Charging point operators are often those who enter the contracts for power related services with electricity suppliers, grid operators, and most recently demand response aggregators. Especially if the charging points are located within other objects (within the same points of common coupling to the grid). However, this task can also be on the CPOs side if the charging point business is separated from the other businesses.

From the EVs point of view, there can also be several distinctive roles. The first ones are the EV manufactures, distributors and resellers. As in the case of charging points, these do not take part in everyday charging operation and they are mentioned only to have a complete picture. However the EV owners and users can be different. For example, if a company buys an EV the users can be different. It is private matter whether to connect EV owner or EV user to EMP, and both are valid.

In general the EV owner/user pays for the charging to the EMPs, EMPs keep their part (ICT charging platform costs plus profit) and forward the payment to the CPOs. CPOs keep their part (CPs' operating and management costs plus profit) and forward the rest of the money to CP owners. CPs owners keep part (investment into CPs plus profit) and forward the rest of the money to energy related companies (for supply, aggregation and grid fees). If energy arbitrage or flexibility provision through an aggregator is the target, EVs and EMPs cannot directly provide it, only the CP owners or CPOs can.

The question that will be tackled within the publications of second contribution are: is this the right way to extract the flexibility from EVs? In this, conventional concept, electricity suppliers and aggregators are connected to the charging points, but is there a way to connect them to EVs? Is it a better or worse solution? From the power system and EV owner/user point of view?

### **2.2.4 Power and E-mobility System Intersection - Downsides and Upsides**

The EVSE impact on power system can be substantial in the following decade. If the EVSE predictions from Section 2.2.2 are to be compared to the rest of the power system, energy and power-wise, its general impact can be understood. As a reference of the power system values, the global and ENTSO-e system data will be used (totaling 36 European countries). According to [28], in 2018. in ENTSO-e system the total power consumed was 3600 TWh whilst the peak power was recorded in 28.02.2018 18:00 – 19:00 of 0.59 TW. The world's total electricity generation in 2018 was around 22315 TWh [29], and while the world peak power is hard to estimate, we will scale it to match total consumption vs peak power ratio of

ENTSO-e, which makes around 3.66 TW. Cumulatively, STEPS scenario estimates 470 TWh of EVSE consumption and installed capacity of 0.72 TW (not including two/three wheelers), whereas the SDS scenario estimates 890 TWh and 1.3 TW [23]. Compared to worldwide energy consumption from 2018, the EVSE would consume from 2% to 4% annually. If power is to be compared, we can see that power installed in EVSE can in the worst case (full charging on all chargers) can occupy up to 20% to 35% of approximated worldwide peak power. From the energy perspective it doesn't seem like a big issue, even though the share increased significantly compared to 0.35 % of EV consumption in 2019. However, the potential share in peak power can be extremely high. Note that those shares are hypothetical for illustration purposes only, as not all chargers will be fully utilised at once. At the same time the approximated peak power such as used in this small example is rare and the current power is much less than yearly peak. Still, it provides a nice first view on the challenge of EV to power system integration.

To dive one step further into EV-power system integration it is crucial to understand when the EV charging will mostly occur. Most of the vehicle users (including ICE) is of a commuter type and they will return to home after work. High share of vehicles return to home in the afternoon – peak traffic congestion (more information in [30]), roughly at the same time, and if they are electric they would all plug in and start charging process at maximal possible power level. Often, the power system peak also occurs when electricity consumers come to home after work - superposition of the two peaks can lead to increase in overall electricity consumption peak which would require new investments in power generation fleet. The peaks in power consumption are translated to wholesale prices as well, so such charging will mean the charging under the highest prices. Those high powers can also overload the transmission and distribution and lines and transformers or lead to grid voltages deviations higher than allowed. It entails new investments in grid infrastructure as the grid is conventionally dimensioned to survive the highest predicted loading. Since EVSE is connected to distribution level, the local distribution grids will be on the front line to battle against those challenges. The second peak superposition is in the morning (turning on office/industrial equipment + morning traffic) when commuters arrive to workplace and plug in their EVs. This have the identical impact to power system as the afternoon peak superposition. Note, the ownership of the EVSE doesn't matter from the power system standpoint as both charging at private and public EVSE near home/workplace will jointly cause mentioned power system issues. In Section 2.2.2 it has been mentioned that fast charging is a supplemental to slow charging and that it is used to back up the EV users with additional energy. In peak traffic periods the most of the EV users is on-the-road which means that the fast charging stations will also be quite occupied in those periods. Fast charging stations can, at present, provide powers higher than 100 kW per EV. Previous two sentences combined state that fast charging can further increase the peak power consumption.

Apart system adequacy issues (generation fleet and grid insufficiency) the EVs can cause

the balancing issues as well. The increase in peak power load can lead to insufficient number of power plants providing the balancing services (more information in Section 2.1.4) as most of them would be engaged to provide energy for charging. Even if the number of plants is sufficient, the prices of balancing services in those periods will increase as more expensive units must be engaged. Another issues are new variability and unpredictability in power system coming form the EV charging. Variability refers to the mentioned morning and afternoon peak increase when ramping requirements will be further increased. Its noteworthy to mentioned, that the balancing requirements are the highest during those ramping periods [20] and that higher amount of balancing services would be needed during them. Unpredictability of the charging can request the increase in the amount of required balancing services thought day as the EVs abound with uncertain elements such as: exact arriving times to EVSE, energy consumption during driving, battery efficiencies, unexpected trips etc.

Average battery size of full electric EV is from 48-67 kWh in 2020 [31] and is expected to increase to 60-70 kWh in 2030. Estimated global EV battery capacity in 2019 is 0.17 TWh, whereas the expected capacity in 2030 is 1.5 TWh and 3 TWh in SDS and STEPS scenarios [23]. The total energy storage capacity within power systems worldwide in 2017 was 1.5 TWh and it was mostly (98%) in pumped storage hydro power plants. Electrochemical storage technologies of all types had installed capacity of 3.5 GWh (2017), within this number li-ion had around 2 GWh [32]. Estimated installed capacity in 2030 in stationary batteries ranges from 0.15-0.45 GWh [32]. It can be seen that EVs will have joint battery capacity of 3-10 times higher than stationary electrochemical storage in 2030 which makes them as one of the potential leaders in power system flexibility provision as elaborated in detail in 2.2.5 .

### **2.2.5 EVs as Flexibility Providers – a Myth or a Valid Pathway**

The leitmotiv of this thesis is contained in the following two sentences:

- If EVs are not managed properly they can cause severe issues to the power system and the benefits of transport electrification are annulled by them;
- If the EVs are manged properly they would not cause issues to the power system but can lend a helping hand to power system decarbonisation measures.

The first one is elaborated in detail in the Section 2.2.4. In this Section the second bullet will be framed. In general, EVs have relatively high: installed power, battery capacity, charging availability, and predictability of behavior. Section 2.2.2 states that the slow charging EVSE equipment ranges from 3.3 kW to 11 kW. On-board-chargers (OBC) share the similar range form 3.3 to 11.5 kW with tendencies to increase in future [33]. Those power capacities are larger than large household loads (air conditioners, washing machines, ovens...) often regarded as future flexibility providers which range from 1-3.5 kW [34]. They are even larger or equal to household allowed power limits which are usually in range from 5-10 kW. In Section 2.2.4

it is already stated that cumulative effect of installed EVSE and EV stock battery capacity on power system is significant. If EV batteries are to be compared with EVSE and OBC power levels it can be seen that charging process for average battery with capacity of 60 kWh (more detail in Section 2.2.2) takes up to ten or even more hours (from empty to full state-of-charge or SOC). From the perspective of vehicle user it is a lot more than ICE charging at gas stations. Daily travel distances in Europe are mostly less than 100 km [30] with average EV consumption of 0.2 kWh/km [35] making daily EV consumption rarely above 20 kWh. Such consumption would require around 3 hours of slow charging daily. The rest of the parking time and with the rest of accumulated energy (not used for driving) EVs are free to provide flexibility services to the power system operators. Compared to stationary batteries EV batteries have smaller power-to-energy ratio meaning that they have less restrictions on SOC when providing full power. Parking time can be seen as availability periods when EVs are coupled with power system and ready to be charged or provide flexibility services. According to [30] and [36], in the peak traffic periods almost 90% of EVs are parked and therefore ready to be utilized as the flexible asset by the power system. It can be seen that cumulative fleet behavior is rather predictable, and the EV aggregators could have a solid predictions of their fleet behavior which is the base for any kind of flexibility provision by EVs. All of this leads to a conclusion that there is a sufficient flexibility accumulated within EV fleet.

In order to mitigate negative effects of the EV charging, it must adapt to variable power system conditions. This defines the *smart EV charging* concept. Primarily, the smart EV charging can be influenced implicitly by charging price. In general, abundance of electricity means low price, while scarcity of electricity means high price. Therefore, by adequate wholesale price forecast EVs can be scheduled to charge when prices are low. This is often termed as Grid-to-Vehicle or G2V and it resembles the demand response concept. Apart of being charged from the grid, there is a possibility to discharge energy at high prices back-to-the grid which is often referred to as vehicle-to-grid or V2G concept [37], [38]. Combination of charging at low and discharging at high price resembles the electricity arbitrage process utilized by stationary batteries. Even though the most often cited and researched is G2V/V2G by wholesale prices the concept is the same if dynamic retail prices or dynamic grid tariffs are used. Along implicit smart charging/discharging EVs can be explicitly called to provide service, such as balancing (Section 2.1.4), and to increase/decrease their current charging/discharging level.

Individual EV batteries are small compared to minimal bid sizes (usually 1 or 5 MW) on different markets [16], [11]. If they want to form the bid of sufficient size the EV fleet must act as one entity which is usually termed EV aggregator. The Ev aggregator deals with wide range of actions from communication with each EV, creation of market bidding strategies for the whole fleet, dispatching the charging/discharging signals, forecasting market and EV behaviour etc. The thesis will try to understand the effect of smart charging on the overall power system

balance and the why how to the services can be transferred to the TSOs. To do so different operation research methods will be used and they basic concepts are described in the following Chapter.

## **2.3 Connection to the Contributions**

The first contribution of the thesis, the EV fleet optimal charging model, is related to the issues stated in Sections 2.1.1, 2.1.2, 2.2.2, and 2.2.4 where overall system shortcomings and benefits from EV integration are defined, modeled and tested. The used EVs' charging strategies are classified and defined in Sections 2.1.5 and 2.2.5. The second contribution, methodology for evaluating the EV integration benefits, builds its scenarios from the global trends and assumptions presented in Sections 2.1.1, 2.2.1, 2.2.2. The second part of the methodology passes from the power systems to electricity markets where Section 2.1.3 declares the market environment, and the 2.2.3 defines the main players in the conventional e-mobility sector. The last part of the dissertation, tackling the strategic market positioning of EV aggregator, have its roots in energy and ancillary service market description from Sections 2.1.3 and 2.1.4, but the main ideas are defined in Section 2.2.5.

# Chapter 3

## Modeling Framework

The research conducted under this thesis tackles three subtopics: EV charging effect on power system operation and balancing, EV-based concept for smart charging integration into e-mobility system and EVs bidding strategies on energy and balancing services markets. To couple will all of these topics different mathematical models in the area of operations research are designed. This Chapter will go through the very basics of these models to make a mathematical introduction for the publications listed in the Chapter 5.

### 3.1 Mathematical Programming Models

Operations Research (OR) is an analytical method of problem-solving and decision-making used in the management of processes and organizations. OR is the study of how to make decisions efficiently. Mathematical programming, the other term for optimization, is one of the main tools within the operations research. Optimization is an approach to a complex decision problem involving selection of optimal values for a wide range of interrelated variables focusing on one objective function which quantifies the the quality of decision. Objective function (OF) is maximized and minimized and subjected to constraints holding some physical, market, policy limits. The quality of optimization solution depends on model builders capability to adequately represent real-world processes with adequate approximations and to adequately interpret the results. There is always a trade-off between problem complexity and the tractability and finding the right recipe is the main task of a model builder.

#### 3.1.1 Different Types of Models

The three types of optimization problems are recognized in [39]: linear, constrained and unconstrained problems. The constrained and unconstrained problems form the nonlinear algorithms and are not used in this paper. Introduction to optimization can also be found in [40].

### **Linear Programming**

Linear programming (LP) is characterized by linear equalities and inequalities as objective functions and constraints. It is the most widely used optimization technique due to its rather simple form and the fact that many real-world applications can be literally written or approximate with linear relationship. Examples of continuous processes are production of beer, flow in water pipes or smart charging of an EV. The authors of [39] singled out conic programming as natural extension of linear programming. In LP, the variables form a vector which is required to be component-wise nonnegative, while in conic programming they are points in a pointed convex cone. Semidefinite programming (SDP) is one type of conic programming where the variable points are symmetric matrices constrained to be positive semidefinite. Nonnegativity constraints on real variables in LP are replaced by semidefiniteness constraints on matrix variables in SDP. Another important branch of conic programming is p-order cone programming where the most used subbranch is second order cone programming (example can be found in [41]). Other non-linear extension of linear programming are quadratic problems where linear functions are replaced with quadratic ones [42].

The solutions of the LP includes the optimal value of the OF, the optimal value of each variable, the amount of slack or surplus in the constraints and shadow price of each constraint. If a constraint is binding, then the corresponding slack or surplus value will equal zero. Otherwise there will be either slack or surplus different than zero. When less-than-or-equal constraint is not binding, then there exist some unused (or slack) resource and the amount of this resource is represented with slack variable. When greater-than-or-equal constraint is not binding, then there exist some extra (or surplus) resource generated and the amount of this resource is represented with surplus variable. The shadow price (dual variables, marginal values) is another value connected with each of the constraint. It represents the change in value of the OF regarding the change of Right-Hand-Side (or the limit on the resource) of the constraint. For non-negativity constraints, the shadow prices are often referred to as reduced costs.

### **Integer and Mixed-integer Programming**

The LP models are continuous meaning that the decision variables can be fractional, and often this is a realistic assumption. However there are real-life processes that only can take one integer value, often they are only binary and can take either value zero or one. Models with only integer values are solved using integer programming (IP) [42]. If a model can have both integer and continuous variables than it is a Mixed-Integer Linear Program (MILP). Examples of integral variables are selection of number of potential investments, choosing a location of new building or other infrastructure element, scheduling of maintenance crews or operating units etc. Binary variables can be used to express logical conditions or to represent nonlinear functions such as

fixed costs, piece-wise linearisations, diseconomies of scales etc. All models within this thesis have been designed as either LPs or MILPs as they provide sufficient accuracy and tractability for issues in question.

### 3.1.2 Procedures for Solving Linear and Integer Problems

Most algorithms designed to solve large optimization problems are iterative in nature. Typically, the algorithm selects an initial solution vector and generates an improved vector which behaves as an initial solution vector for the next step. This procedure is repeated until improved solutions can be found and it approaches to the optimal solution. The algorithms verification that they do indeed reach the optimal solution is often called the global convergence analysis, whereas the rate at which the sequence of iterations converges to the optimal point is termed local convergence analysis. This convergence rate can be used as a measure of the problems tractability. In this Section the brief introduction into LPs (simplex and interior point) and IPs used in this thesis is provided.

#### Simplex Method

LPs can be generally solved by simplex methods or by interior methods. General property of LPs is that the solution lies on the vertices of the feasible region. The simplex method exploits this property by starting at a vertex and moving from vertex to vertex, improving the value of the objective function with each move. The iterative sequence reaches the optimal solution after a finite, initially unspecified, number of steps. The fundamental theorem of LP says that it is necessary to consider only basic feasible solutions when seeking an optimal solution. To elaborate, if the system  $\mathbf{Ax} = b$  has a solution then there is one solution that has at most  $m$  nonzero entries. This is a solution of  $m$ -element subset of  $\mathbf{A}$  (from the standard LP form show in eqs. (3.1) – (3.3)) which is termed as *the basis*. The basis is the  $m \times m$  element matrix which is subset of  $\mathbf{A}$  (the variables outside  $\mathbf{B}$  are zero). The basic feasible solution is, therefore, the solution of the basis matrix  $\mathbf{B}$ . The task of solving a linear program is reduced to that of searching over the basic feasible solutions. Please note that the basic feasible solutions are exactly the vertices of a feasible region. The simplex method proceeds from one basic solution to another in a way that it minimizes OF. Using the pivot operation, a new basic solution can be generated from an old one by replacing one basic variable by a nonbasic variable (more details can be found in [39]). The algorithm continues if pivoting on some of the variables will decrease (in minimization) the OF even further, and if the pivoting on any of the variables do



not decrease the OF further than the optimal solution has been found.

$$\min \quad \mathbf{c}^T \mathbf{x} \quad (3.1)$$

$$s.t. \quad \mathbf{A} \mathbf{x} = \mathbf{b} \quad (3.2)$$

$$\mathbf{x} \geq \mathbf{0}. \quad (3.3)$$

The eqs. (3.1) – (3.3) show a standard form or LP formulation where  $x$  is a decision variable vector,  $c$ ,  $b$  and  $A$  are input parameters. Simplex methods can be further classified as: primal, dual and primal-dual algorithms [39]. As explained later, each original LP problem has its twin, the dual problem. The simplex method can be utilized on both of the twin models as, in some cases, it cannot be performed efficiently in one of them but can in other. The primal-dual algorithm works simultaneously on the primal and the dual problems and can, depending on a problem-at-hand, come to solution more efficiently.

### Interior Methods

The simplex method proved to be an efficient method for vast number of linear problems to be solved. However, if the number of vertices is large and the simplex algorithm visits all of them (as it is proven for some problems [39]) the solving time would be exponential to the size of the problem. Interior point/barrier algorithms behave differently compared to simplex method. The interior algorithm achieves optimization by going through the middle of the feasible region rather than around its surface (as simplex does). The interior algorithm treats the problem by introducing nonlinear terms and do not generally obtain a solution in a finite number of steps but iteratively converges to the optimal solution [39]. Those algorithms are often termed as search algorithms such and one of the examples is the Newton's method. The interior barrier problem (BP) of LP form eqs. (3.1) – (3.3) can be represented with eqs. (3.1) – (3.3). If  $\mu \rightarrow \infty$  the solution reaches the analytic center of the feasible region, and by decreasing it towards zero ( $\mu \rightarrow 0$ ) the path converges to the analytic center of an optimal face (optimal solution). The basic idea behind the interior methods is to solve barrier problem for smaller and smaller values of  $\mu$ . As in the case of simplex algorithm, the method can be utilized on primal and dual problem or one their combination.

$$\min \quad \mathbf{c}^T \mathbf{x} - \mu \sum_{j=1}^n \log x_j \quad (3.4)$$

$$s.t. \quad \mathbf{A} \mathbf{x} = \mathbf{b} \quad (3.5)$$

$$\mathbf{x} \geq \mathbf{0}. \quad (3.6)$$

### **Branch-and-bound Methods**

Integer problems are hard to solve and they fall into domain of combinatorial analysis. Special algorithms are designed to solve integer programs, but they are usually tractable for an order of magnitude smaller problems than linear programs. One of the most used algorithms is the branch-and-bound (BB) algorithm [42]. The BB algorithm divides the feasible area into into several subareas, and, if necessary, to further divide those subareas into sub-subareas. This subdivision can be done by a number of BB methods and here an general BB approach will be described.

In a nutshell, the IP is a linear program with integrality constraints. In a minimization problem, it means that pure LP solution will always be lower bound of IP OF optimal value. In other words, each integer feasible point is an upper bound to optimal LP solution. As a first step, the feasible region is not divided and the integrality constraints are dropped. The integer variable is solved as continuous (lets assume there is only one integer variable in a problem). Solution of such problem becomes the lower bound for minimization problem. In the next step, the LP problem is divided and solved for two cases: one where integer variable is higher-or-equal than rounded up variable solution form the first step and the second case where integer variable is lower-or-equal than variable solution form the first step. Each of the divided problems is solved as LP again and the one with the lowest value is the optimal integer solution (this is still higher than initial LP solution). If there were two integer variables the subareas would be further divided on the integrality of the second integer variable. If there are even more integer variables there would be even more levels of subdivisoning. The subdivided areas which end up in infeasible area are discarded and the procedure follows another path. Which of the integer variables to chose first for a subdivision is usually done by some kind of heuristics. All paths must be checked and the one with the lowest solution becomes the optimal IP solution of the whole problem. For the MILP problems the procedure is the same as for the pure IP problems as the subdivisoning is only done by integer variables. A special algorithm can be used for IP with only binary variables, it is called implicit enumeration and explained in details in [42]. Also there are cutting planes algorithms for IP but they are, generally, outperformed by BB algorithms.

## **3.2 Different Types of System/Market Modeling**

The power system is composed of technical units and the grid which interconnects them. The technical units can be of different technologies and roles within the system. Three main types of units can be found: generators (generate energy), storages (store energy for the latter use) and demand facilities (consume energy). Traditional power systems were monopolistic companies where they operated with large generators (thermal, hydro, nuclear) and large storage facilities

(mostly hydro pump storage) to supply the demand facilities (end-users/end-customers) with energy. They didn't operate the demand facilities and as such they were completely inflexible from the power system standpoint. To optimally operate a power system in this concept the demand must be forecasted ahead of delivery and the generators and storage facilities must be scheduled to follow it. Therefore, the optimal power scheduling algorithms were designed in a way that the large generators and storage facilities were modeled in detail with their: variable (fuel) and fixed costs, technical minimums, ramping rates, start-up and shut-down times and costs, power balance, security requirements, water constraints (hydro and pump storage) etc. This scheduling approach is called centralized since the whole system is scheduled/operated from one central point.

### 3.2.1 US vs EU Electricity Market Modeling

To couple up with complex centralized scheduling algorithm it is usually divided into two parts named: unit commitment (UC) and economic dispatch (ED) [43]. Unit commitment deals with integrality constraints and it results with on/off state for all generators with the aim of cost minimization. UC is the process of deciding which and when unit starts-up or shuts-down taking into account technical and security constraints while supplying the demand. Usually it is observed for 24h horizon and it is a MILP problem. There are different formulations of UC problem as can be found in [44]. To ease the computational effort, proposals have been made for tighter UC formulations [45], to group the generators per type and to use integer [46], [47] or even linear variables to represent set of units binaries [48].

The second part selects the appropriate variable power generation level for online units supplying the demand with the lowest cost while complying with technical constraints and transmission network [43], [49]. The observed horizon is usually 1 hour and it is a simple LP problem. The dual variables of balance constraint of ED are the locational variable prices (LMPs). If both UC and transmission network are observed simultaneously it is called network constrained UC – NCUC [43], [50]. Today, most of the US ISOs and RTOs use the NCUC algorithm. Large number of different formulations of ED can be found combining various constraints, e.g. in [51] they integrate ramping constraints and call it security constrained ED.

After the power market liberalization US electricity markets were designed in a way that they still hold onto centralized dispatch approach even though the generators are privately owned. The generators and pump storages are obliged to provide all their economic and technical bids (data) required for optimal scheduling algorithms to the independent system operator (ISO) or regional system operator (RTO) who are in charge of power system and electricity markets operation. The ISO/RTO runs the NCUC algorithm and the cheapest units are scheduled. The scheduled units are obliged to run as promised at ISO/RTO market. Apart the electricity market, the ISOs/RTOs also operate the ancillary service markets often as a co-optimized

energy-service procedure. The ISOs/RTOs do not own the transmission grid but model it within their markets and in-effect provide congestion management through it as well (LMPs). Example of the state-of-the art UC models can be found in [52], [53], [54].

After the liberalization in Europe, the electricity markets were organized on independent power exchanges where all market participants (including generators, storages, traders and consumers) can submit their bids. Those bids do not involve technical parameters of the units but only the price-volume pairs at which a market participant is willing to generate or consume electricity. Price-volume bids can be created by the participant in any way it pleases him. Once accepted the market participant must generate or consume traded power on the portfolio level. It means that it self-schedules within its portfolio without the TSOs consent. The market participants are incentivized to self-balance their real-time positions and to lower their imbalance penalties. TSOs are separate entities which deal own the grid and operate it in the real time. They separately organize the ancillary service and congestion markets or procure them bilaterally. In such markets the UC and ED or NCUC algorithms cannot be applied for the power exchanges nor for the ancillary services/congestion management. The algorithms on those markets are used to choose the cheapest units only based on their bids and based on the specific products features. The EU-style markets do not take into account the grid constraints and such models are termed as copper plate models.

### 3.2.2 Price Taker vs Price Maker

To be able to create adequate bidding strategy on energy and ancillary service markets, the participants must either know all the techno-economical parameters (US-style) or the bids and bidding strategies of their rivals (EU-style). Since such data is often not publicly accessible, the alternative approach would be to forecast the market price (examples of energy market forecasting [55], [56], [57], examples of aFRR forecasting can be found in [58], [59]) using all available data and, according to that price, optimize their own operation observing only their individual technical and economic constraints. This approach is a single level price-taker model since the decisions of the participant cannot influence the price [60], [61], [62].

The other approach (price-maker) is a bi-level optimization where the participant models its technical process and economic position in the upper level, and the market clearing procedure is modeled in lower level model. One of the potential solution to solve the bi-level problem is using the mathematical problem with equilibrium constraints (MPEC) as in [63] and [64]. The lower level is different for the US [63] and for EU style markets [64] as explained in the previous two paragraphs. In such model structure the decisions of the participant in the upper level effect the lower level price creation whereas the lower level created prices affect the upper level decisions. However, the decisions of one market player are rarely of such significance to directly influence the price. If such influence exists than the participant holds a market power

and can create the prices to maximize its profit. In a such market there is a lack of competition and the regulators must find a way to mitigate those effects. It should be noted that when a market participant tries to influence the price with his behaviour it means that his bids are marginal and that if the price deviate from the forecasts it can end up with unaccepted bids (without the trade at all). Examples of MPEC modeling can be found in [65], [66], [67]. The other issue is that for such modeling, the market participant must know all techno-economic parameters in US-style markets and all submitted bids in EU-style markets. EU-style markets are modeled as copper plate, meaning that it is even less possible to influence the since since the grid is not creating the LMPs. Examples of price-maker models are [68], [69], [70], [71], [72].

### **3.2.3 Uncertainty in Optimization**

Another classification of the optimization models is based on the level of certainty of the input parameters [42], [73]. If all the parameters are know constants it means that that the optimization is deterministic. If the parameters entail certain amount of uncertainty, the models can be termed as stochastic. If the parameters can vary systematically and influence the solution of the optimization model, the models are termed as parametric. Stochastic and parametric models are much more complex than deterministic and finding a solution is more difficult. The uncertainty comes form the inherent randomness of the natural phenomena or human behavior, i.e. from the inaccurate knowledge of input information [74]. Ignoring the uncertainty can lead to wrong decisions made and to suboptimal solutions. More detail view of uncertainty modeling is provided in Section 3.3.

### **3.2.4 Static or Multi-stage Problems**

The optimization problems can be classified according to the number of time periods considered within the optimization. The models can be one-stage or static and multi-stage [75], [76]. Static models solve the problem for one observed period and those solutions cannot be changed by the solution of the subsequent period models. Static models require that all decisions have to be fixed up in-front. Multi-stage formulations are, on the other hand, trying to capture the dynamics of successive information disclosure. One of the possible solutions to multi-stage problems can be dynamic programming concepts where each of the stage is observed separately, either through forward or backward propagation [42]. The models of the multi-stages are often interdependent as the solution of one model affects the solution of the other. The interplay between uncertainty (defined in Section 3.3) and time is important to many decision problems. Those problems require a sequence of decisions which react to time-evolving outcomes and the information about those outcomes is disclosed gradually [77]. Explicit consideration of temporal

relationships between parameters true realizations and (partial) decisions adds complexity to the problem, but improves the solution (brings it closer to optimality).

When electricity markets are observed, they often have a certain point in time when bids are no longer allowed, i.e. the gate closure time. The bidding algorithms must finish and send the results to the market operator before the gate closure time. This can be considered as one stage problem if only one market is observed. However the electricity markets range from years-ahead through day-ahead to intraday and real-time markets. If bidding strategies over all those markets are observed the model must be a multi-stage where each of those markets makes one stage.

Another aspect is that electricity markets are often designed as some-time-ahead of delivery trading (the most famous example is day-ahead) and up to the actual delivery there are many uncertainties which can happen which require new decisions. This is why when the market bidding algorithms are observed they are often separated to two stages: first stage - some-time-ahead market and the second stage real-time realization (real-time market, intraday market, balancing market, imbalance settlement etc.). This two stage separation is a general concept of standard stochastic multistage problems. The first stage deals with variables that have to be decided before the actual realization of the uncertain parameters. After the realization of those variables the second-stage or recourse variables can be decided. Second-stage variables can be seen as a corrective measures against issues which can arise from the issues caused by uncertainty realizations. The second-stage problem may also be an operational-level decision problem following a first-stage plan and the uncertainty realization [78].

### **3.3 Incorporating Uncertainty Within Bidding Strategy**

Two main concepts of uncertainty modeling used in this thesis will be elaborated in a more detail manner: scenario-based and robust stochastic models. Both of them are first defined as deterministic and afterwards the stochastic terms are added on top of it.

#### **3.3.1 Scenario-based Stochastic Programming**

Stochastic programming is a direct extension of deterministic model where uncertainty is modeled assuming prior knowledge of probability density function of uncertain parameter. The stochastic programming is the oldest form of incorporating uncertainty in mathematical programming models. The first notion of stochastic programming proposed usage of estimated values for uncertain variables which in reality still means usage one single point deterministic variable [79]. Such observation of uncertainty assumes risk-neutrality from the decision makers point of view. Incorporating multiple number of possible realizations of uncertain parameter

proportionally grows the size of a problem, and this number increases exponentially with the number of time periods and parameters [80]. However, the solution improves significantly and a trade-off must be found. Solvability of stochastic models is, therefore, limited with large problem dimensions. This can be improved by different techniques such as decomposition, scenario generation and reduction etc. Decomposition techniques can be based on primal and dual methods. The primal divide the problem into series of subproblems, while the dual techniques deal with relaxation of non-anticipativity constraints through Lagrangian function [77]. The examples of partitioning are one timestep one problem or one scenario one subproblem [78]. The problems with infinitely many scenarios are often tackled by generating the large number of scenarios (scenario generation) and reducing it to the number which is the best trade-off of accuracy and compatibility.

The stochastic programming is mostly used with fixed/integer number of possible realizations (discrete distribution of random data) of an uncertain parameter and each of those realizations are termed as scenarios (this where the term scenario-based stochastic programming comes from). The realizations can be written as finite sums where each constraint is duplicated for every scenario. These are so-called non-anticipativity constraints and they ensure that decisions for individual scenarios do not differ before the associated scenarios can be distinguished from one another [77]. The problem, in this case, can be worked out as large deterministic formulation (often term as *deterministic equivalent problem* of the stochastic programming problem). A static stochastic programming incorporates the first stage variables (or here-and-now decisions) which must be feasible for all scenario realizations. However, if the the problem is multistage (introduction in Section 3.2.4) than the recourse level also exist [81]. The recourse variables (wait-and-see) are made after the realization of uncertain parameter happens. The general framework of such problem is given by eqs. (3.7) - (3.11) [74], [82].

$$\min \quad \mathbf{c}^T \mathbf{x} + \sum_{s \in \mathcal{S}} \pi_s \mathbf{d}_s^T \mathbf{y}_s \quad (3.7)$$

$$s.t. \quad \mathbf{A} \mathbf{x} = \mathbf{b} \quad (3.8)$$

$$\mathbf{B}_s \mathbf{x} + \mathbf{C} \mathbf{y}_s = \mathbf{e}_s \quad (3.9)$$

$$\mathbf{x} \geq \mathbf{0}, \quad (3.10)$$

$$\mathbf{y}_s \geq \mathbf{0}. \quad (3.11)$$

The eqs. (3.7) – (3.11) lean back a standard form or LP formulation, shown with eqs. (3.1) – (3.3), where  $x$  is a decision variable vector of the first stage,  $c$ ,  $b$  and  $A$  are input parameters connected to the first stage. The second stage variables are defined with vector  $y_s$ , and constrained with the parameters  $d_s$ ,  $B_s$ ,  $C$ , and  $e_s$ .  $\Phi$  is the probability of occurrence of specific scenario.

Note that removing all the terms with  $y_s$  the model would become one-stage or static. The solution of the stochastic program can be measured through several indices such as the value of the stochastic solution or the expected value of perfect information [80], [77], [74]. The former index compares the stochastic solution to the solution of a problem where all uncertainties has been resolved prior the decision making (deterministic formulation with perfect information). The latter one compares the stochastic solution to that of solution where all uncertainties are switched with their expected values (deterministic solution with expected realization of random parameter). Methods for solving stochastic integer or nonlinear problems are also proposed [78], [82]. In power system stochastic approach is used to model different sources of uncertainty such as prices [83], [61], wind operation [84], [85], [86], [87] etc.

### 3.3.2 Robust Programming

Robust programming is also an extension to deterministic programming. In contrary to stochastic programming, it doesn't utilize probability density function as it can be hard to identify and bound estimation errors [77]. The robust programming use only the set of possible outcomes not their individual probabilities [88], [89], [90]. In robust programming uncertainty is modeled through uncertainty set which is set of equations and parameters which bound the uncertain parameter.

There are several robust formulations as presented in [91] and [92] and can be grouped as: strict robustness, cardinality constrained robustness, adjustable robustness, light robustness, recoverable robustness, regret robustness etc. Strictly robust formulation is the cornerstone and in a way the easiest to implement. However, the solution of the strictly robust problem is feasible for all possible outcomes of the uncertain variable. It means that all the uncertainty parameters can simultaneously change to their worst-case value. In some circumstances this is desirable feature, but often it leads to over-conservative solution. To create solution which is much more practically applicable this framework has been relaxed to many different formulations. The cardinality constrained formulation prevents the possibility that all uncertain parameters change to their uncertain value simultaneously. This formulation allows only  $\Gamma$  uncertain parameters to change per constraint at the same time. The follow up is the adjustable robust formulation which builds up on the multistage nature of the optimization problems. More details on other robust formulations can be found in [92]. In the two stage case this means division on the first (here-and-now variables) and second (wait-and-see variables) stage, this is analogous to two-stage stochastic formulation mentioned in Section 3.3.1. The general structure of such model is show with eqs. (3.12) - (3.15) [92].



$$\min_{(x)} \max_{(B,C,e)} \min_{(y)} \mathbf{c}^T \mathbf{x} + \mathbf{d}^T \mathbf{y} \quad (3.12)$$

$$s.t. \quad \mathbf{A} \mathbf{x} = \mathbf{b} \quad (3.13)$$

$$\mathbf{B} \mathbf{x} + \mathbf{C} \mathbf{y} = \mathbf{e} \quad (3.14)$$

$$\mathbf{x} \geq \mathbf{0}, \quad (3.15)$$

$$\mathbf{y} \geq \mathbf{0}. \quad (3.16)$$

The uncertainty is observed on constraints, but the same applies even if the uncertainty is in the OF as each OF can be rewritten as one constraint (in this case it would look like:  $\min z, \text{ where } z \leq \mathbf{c}^T \mathbf{x}$ ). Variable  $x$  and parameters  $A$ ,  $b$  and  $c$  apply to the first stage. Variable  $y$  resembles second-stage variable where parameters  $B$ ,  $C$  and  $e$  are uncertain variables. If the second stage variable is mitigated the problem becomes static (cardinality constrained). The static problem can be reformulated using duality theorem and strong duality theorem to linear robust counterpart. The adjustable robust formulation uses the same technique to join two innermost sub-problems, however it requires additional techniques to be solved such as decomposition techniques [93]. Often used decomposition techniques in power system modeling are benders decomposition, column and constraint generation, (more information can be found in [94]). Robust optimization is often used method in power system research, some of the examples are: [95], [96], [97], [98], [41].

### 3.3.3 Other Methods

#### Distributionally Robust Stochastic Optimization

Distributionally robust stochastic optimization is an intermediate approach between stochastic and robust programming [77]. In the stochastic programming knowledge of the probability distribution function is required but the approach is not robust to the error of this function. The robust programming on the other side is overly robust and often unrealistic but does not require detail knowledge of future uncertainty. Combination of the two algorithms can provide sufficient robustness without being too conservative or risk-averse. Instead of one distribution, this approach considers a set of distributions and chooses one (the worst one) to optimize the OF. This approach hedges against the worst possible probability distribution. This set of distributions can be termed as *ambiguity set*. It can be concluded that the stochastic optimization minimizes the expected cost, robust optimization minimizes worst-case cost, while the distributionally robust stochastic optimization minimizes the worst-case expected cost. Examples of this method in power system area can be found in [99], [100], [101] [102] etc.

### **Scenario-Based Robust Optimization**

Rather similar approach of intermediate scenario-based and robust optimization can also be envisioned where the robust formulation is used to find the worst-case scenario. In contrast to distributionally robust stochastic optimization, this approach do not add information about probability distribution function (it doesn't include the whole family of distributions) but it finds the worst scenario which is obtained from only one distribution. This approach is sometimes termed as scenario-based robust optimization [103]. It do not observe all the scenarios as in the classical stochastic approach, and it do not need classical uncertainty set as in robust approach but it need a set of scenarios from which it chooses one as the worst-case.

### **Chance Constrained Optimization**

Adding uncertainty on the entire constraint forms probabilistic or chance-constrained programming. The formulation ensures that the probability of meeting the certain constraint will be above defined level [82]. Using probability density function, in the simplest case, the constraint can be relaxed to deterministic formulation and classical modeling schemes can be applied. In a more complex cases where decision variable and random parameters are mutually connected the problem is not easy to solve. Examples of such models can be found in [104], [105], and [106].

### **Online Optimization**

Online optimization is another possibility to tackle with uncertainty input data. It is fundamentally different than stochastic or robust optimization as it do no base its formulation on mathematical programming but on computer science [77]. It resembles sequential decision making and each stage must be cleared before the next one, therefore, it is also a multi-stage algorithm. This approach doesn't need any information concerning the following stages (neither probability density function nor uncertainty set). The complexity of the problem at one stage is not affected by the overall problem size. Such approach can be used where quick decision is required under constant information flow. One of the main concepts within online optimization is *competitive analysis* which similarly to robust optimization tackles the worst case solution. However there are many enhancements which makes the approach more appropriate for real problems. Also, there are algorithms which combine stochastic or robust frameworks with on-line optimization [77].

### 3.4 Models Used in This Thesis

All the modeling within the thesis is based on linear or mixed-integer linear programming introduced in Section 3.1.1. Simplex and interior point procedures were used interchangeably depending on the problem at hand, the one with the better computational characteristics was commonly the preferred choice. Introduction to those solving procedures was given in Section 3.1.2. For the integer problems, branch-and-bound procedure was used, it is also explained in the Section 3.1.2. Unit commitment models, explained in Section 3.2.1, were used in the publications within the first and partially second contribution, to investigate the system-wise unit scheduling changes when EV integration occurs. However, part of the second contribution and the third contribution rely on the price-taker approach explained in Section 3.2.2. Those models assume perfect forecast for prices, and from the price aspect all of them are deterministic. The models within the second contribution dealing with new concepts of EV aggregation are considered as one stage (day-ahead) proof-of-concept models. For clearer understand, the concepts of uncertainty and time dimensionality are briefly elaborated in Sections 3.2.3 and 3.2.4. The models within the third contribution are based on those concepts as they introduce uncertainty from the reserve activation side. These can be considered as a two stage models without recourse, where the first stage is day-ahead scheduling and the second stage is disclosure of the uncertain reserve activation. The uncertainty is modeled using two different methods, the scenario-based stochastic and robust optimization, introduced in Sections 3.3.1 and 3.3.2. The other methods the Section 3.3.3 are mentioned as they are the next steps in the algorithm development, which is out of the scope of this dissertation, as explained in Section 7.2.

# Chapter 4

## Main Scientific Contributions

The thesis is build around three major scientific contributions. The first part of the thesis deal with creation of a new model for optimal charging scheduling of a fleet of electric vehicles with the goal of providing reserve services and increasing overall power system flexibility. The model is designed to easily evaluate how the EVs affect the unit commitment of a power system from the technical standpoint. Second part defines methodology for evaluating benefits of different charging strategies of a fleet of electric vehicles with the goal of increasing the share of variable renewable energy penetration. Finally, the last part of the thesis creates strategic positioning model for electric vehicle aggregator on electricity and ancillary service markets.

### 4.1 Model for Optimal Charging Scheduling of a Fleet of Electric Vehicles

The model for optimal charging scheduling of a fleet of electric vehicles has a task to technically evaluate the changes in power system unit commitment process when EVs are incorporated into the system [Pub<sub>1</sub>]-[Pub<sub>3</sub>], [Pub<sub>6</sub>]-[Pub<sub>7</sub>], [Pub<sub>10</sub>]-[Pub<sub>12</sub>]. Firstly, the power system model for unit commitment process is designed. The model takes into account conventional power plants, namely thermal, nuclear and hydro. Objective function was to minimize the cost including emissions and at the same time to provide sufficient energy and reserves. It was designed as a *cooper plate* not focusing on grid issues but generation fleet adequacy. To ease the computation, the binary MILP was reformulated to a pure integer MILP where generators on/off states where not used per generator but per generator type. The resolution of the models is one hour with weekly horizon. The model was than updated with RES (wind power) and EV fleet. The EV fleet was designed through one set of integer/continuous variables resembling slow charging of EVs [Pub<sub>1</sub>]-[Pub<sub>2</sub>], [Pub<sub>6</sub>]-[Pub<sub>7</sub>], [Pub<sub>10</sub>], [Pub<sub>12</sub>] (similarly as the fleet of generators). The models clearly demonstrated that slow EVs' charging can be utilized to ease the constraints on the conventional generators and decrease the total cost and emissions.

The next phase of the model development was the integration of battery storage within the fast charging stations [Pub<sub>3</sub>], [Pub<sub>8</sub>], [Pub<sub>11</sub>]. These models demonstrated the necessity of integration of a stationary storage system within the fast charging station. The contribution of the above mentioned publications is in the provision of easy-to-use and tractable model which can be easily tailored to specific needs of the policy maker. Publications [Pub<sub>9</sub>], [Pub<sub>10</sub>], and [Pub<sub>13</sub>] additionally deal with the integration of EVs into the transmission and distribution grid.

## **4.2 Methodology for Evaluating Benefits of Different Charging Strategies**

The second contribution was the design methodology for evaluating benefits of different charging strategies of a fleet of electric vehicles with the goal of increasing the share of variable renewable energy penetration. It can be divided into two main parts: applying the models from the Section 4.1 and to the concepts proposed in [Pub<sub>4</sub>] and [Pub<sub>14</sub>].

Publications [Pub<sub>1</sub>], [Pub<sub>6</sub>], [Pub<sub>10</sub>], and [Pub<sub>12</sub>] proposed the definition of three generic power system types: thermal flexible and inflexible and hydro flexible. Each of those types holds different conventional unit energy mixes and by applying the research only on them, the researcher can understand the behavior of the observed technology in any of existing power systems. Furthermore, the comparative sensitivity analysis has been proposed where the models were subject to different shares of RES and EVs. The mutual interactions and impact on power system of flexibility sinks (RES) and flexibility providers (EV) can be easily defined. The results demonstrated that impact of smart EV charging and wind power plants is quite different for different system types and RES and EV integration levels. The assumption that more RES and more smart EV charging do not necessarily always hold as there are many constraints which can steer the results in the unexpected direction. The last part of the methodology tackles the issue of the different EV charging strategies. The uncontrolled charging leads to high costs and emissions whereas smart EV charging can cut both of those, especially if they can also provide reserves. Publications [Pub<sub>2</sub>] and [Pub<sub>7</sub>] add additional segments into the overall methodology: the conventional units decommission scenarios, and different policies for RES units. The future energy mix scenarios are observed by decommission of coal and nuclear units where their mutual impact can be understood. Two wind policies are observed: wind curtailment penalization and wind reserve provision. Interestingly, the penalization policy without EVs increases costs and forces unnatural units working positions. With EVs it does not affect at all, as the EVs are mitigating all wind curtailment. If wind power units can provide flexibility, in the cases without EVs they are preferred choice of provider. However when EVs are included they take the lead in reserve provision. Publications [Pub<sub>3</sub>] and [Pub<sub>11</sub>] expand the method on the fast charging stations + battery storage. The principal is the same with additional variables to observe. The

mutual dependencies of slow and fast charging can be observed.

Second part of the methodology is connected with publications [Pub<sub>4</sub>] and [Pub<sub>14</sub>]. Those publications are a bridge between technical observation from papers mentioned in Section 4.1 and the strategic positioning detailed in Section 4.3. Its main premise is that aggregated smart charging can be seen either through smart charging stations or EVs itself as the active market participants. Thorough literature review has been conducted within the publication [Pub<sub>4</sub>] in the area of EV aggregation to prove that almost all state-of-the-art literature assumes smart charging stations not smart EVs. However, in [Pub<sub>4</sub>] it has been demonstrated that EV based e-mobility system enhance the services provision potential stemming from EVs. Two main reasons why CS-based e-mobility is inferior are singled out, the first one is insufficient information on EVs' behavior at other CSs. The CS must forecast the arriving time and SOC without the knowledge of EVs prior charging and driving. In EV-based system, the EV aggregator have knowledge of each EVs current charging/driving and SOC (it however must forecast its future behavior if optimal decisions are to be made). The second reason is that in CS-based system flexibility cannot be transferred form one charging period to another as the charging station only focus to one charging period. In the EV-based system, the EV aggregator can easily precharge/predischarge or postpone charging/discharging to create better position for its EVs on energy market. Additionally, usual omissions such as neglecting grid tariffs or on-board-charger's capacity are also investigated.

### **4.3 Strategic Positioning Model for Electric Vehicle Aggregator**

The final contribution is design of strategic positioning model for electric vehicle aggregator on electricity and ancillary service markets. Deterministic energy bidding model has been developed and demonstrated in publication [Pub<sub>4</sub>]. In reality, many uncertainties are related to such modeling, to name few: price, EV behavior, ancillary services etc. Uncertainty price modeling as well as EV behavior is well studied in the state-of-the art literature and it can be stated that no significant further research is required. The uncertainty of ancillary services refers to the stochastic nature of their activation. The focus is on the active reserves as ancillary services. The state-of-the-art literature either ignores their activation when it comes to fast reserves or creates deterministic models with their average activation as an input parameter. Such observations can be justified for conventional generators where the activation of the reserves cannot significantly affect generator's working point (or market position). However, when reserves are provided from distributed energy resources with energy limitations such as EVs, the activation must be modeled with high accuracy.

Publication [Pub<sub>15</sub>] first defines deterministic model for energy and FCR reserves schedul-

ing taking into account only capacity reservation payments. Afterwards, the results were tested using historic real-world activations. The results have shown that ignoring the activated energy do not affect the operation of the overall fleet, but they can significantly affect individual EVs (SOC limits). Having that in mind, the publications [Pub<sub>5</sub>] and [Pub<sub>16</sub>] proposed novel strategic positioning models to include stochastics of the reserve activation within the optimal bidding algorithm. In [Pub<sub>5</sub>], deterministic model (average yearly activation as fixed amount of activated reserve) is compared to scenario-based and robust stochastic models. The results clearly demonstrate that deterministic model can lead EV batteries to their limits leaving EV users with insufficient SOC levels. For the aggregator, deterministic model can induce reduced real-time possibilities to provide day-ahead scheduled services. Both stochastic and robust model erase those issues but with reduced overall profits (increased costs). The robust model shows better characteristics and requires less data for modeling. Publications [Pub<sub>16</sub>] and [Pub<sub>17</sub>] extends the robust modeling tailoring the dual constraints around several historic features of reserve activation. It demonstrates how easily and with what effect the budget of uncertainty can be changed according to the decision-makers risk attitude. Selecting the worst-case activations as budget of uncertainty, the EV fleet provides less reserve but never ends-up in infeasible area. However, more risk-tolerant decision maker can choose to discard the reasonable percentage of the worst cases which increases its bidding potential but opens him to the risk of undesirable activation scenarios.

# Chapter 5

## List of Publications

The publications considered as part of this thesis are listed below through two main categories: journals and conferences. Criteria to select those publications as part of thesis is that they explicitly mention EVs. Alongside those papers, there are numerous other publications of the author which are closely related to the topic and could be also considered as part of the thesis. Topics of those publications are power markets, battery storage or distributed energy resources (the EVs are a distributed energy resource with battery storage participating on different markets). Due to conciseness of the thesis, they are not listed here but under Chapter "Biography" where full bibliography of the author is listed. The interested reader is invited to read those as well.

### Journal Papers

#### Published

- [Pub<sub>1</sub>] I. Pavić, T. Capuder, and I. Kuzle, "Value of flexible electric vehicles in providing spinning reserve services," *Applied Energy*, vol. 157, pp. 60–74, Nov. 2015, ISSN: 03062619. DOI: 10.1016/j.apenergy.2015.07.070
- [Pub<sub>2</sub>] I. Pavić, T. Capuder, and I. Kuzle, "Low carbon technologies as providers of operational flexibility in future power systems," *Applied Energy*, vol. 168, pp. 724–738, Apr. 2016, ISSN: 0306-2619. DOI: 10.1016/J.APENERGY.2016.01.123
- [Pub<sub>3</sub>] I. Pavić, T. Capuder, and I. Kuzle, "A Comprehensive Approach for Maximizing Flexibility Benefits of Electric Vehicles," *IEEE Systems Journal*, pp. 1–12, 2017, ISSN: 1932-8184. DOI: 10.1109/JSYST.2017.2730234
- [Pub<sub>4</sub>] I. Pavić, H. Pandžić, and T. Capuder, "Electric vehicle based smart e-mobility system – Definition and comparison to the existing concept," *Applied Energy*, vol. 272, p. 115 153, Aug. 2020, ISSN: 03062619. DOI: 10.1016/j.apenergy.2020.115153



### Early Access/Under Review

- [Pub<sub>5</sub>] I. Pavić, H. Pandžić, and T. Capuder, “Electric Vehicle Aggregator as an Automatic Reserves Provider in the European Market Setting,” *IEEE Transactions on Power System*, vol. Under review, pp. 1–8, 2020. arXiv: 2012.11158

## Conference Papers

### Published and Presented

- [Pub<sub>6</sub>] I. Pavić, T. Capuder, N. Holjevac, and I. Kuzle, “Role and impact of coordinated EV charging on flexibility in low carbon power systems,” in *2014 IEEE International Electric Vehicle Conference (IEVC)*, IEEE, Dec. 2014, pp. 1–8, ISBN: 978-1-4799-6075-0. DOI: 10.1109/IEVC.2014.7056172
- [Pub<sub>7</sub>] I. Pavić, T. Capuder, and I. Kuzle, “Defining the Role of Traditional and Low Carbon Technologies in Providing Flexibility for Future Power Systems Operation,” in *Digital Proceedings of the 10th Conference on Sustainable Development of Energy, Water and Environment Systems – SDEWES, 2015*
- [Pub<sub>8</sub>] T. Martinsen, N. Holjevac, B. A. Bremdal, I. Kuzle, J. M. Guerrero, T. Dragičević, I. Pavić, and Q. Shafiee, “Improved Grid Operation Through Power Smoothing Control Strategies Utilizing Dedicated Energy Storage at an Electric Vehicle Charging Station,” in *CIREN Workshop Helsinki, 2016*, pp. 1–4
- [Pub<sub>9</sub>] I. Pavić, N. Holjevac, M. Zidar, I. Kuzle, and A. Nešković, “Transportation and power system interdependency for urban fast charging and battery swapping stations in Croatia,” in *2017 40th International Convention on Information and Communication Technology, Electronics and Microelectronics, MIPRO 2017 - Proceedings, 2017*, ISBN: 9789532330922. DOI: 10.23919/MIPRO.2017.7973652
- [Pub<sub>10</sub>] I. Pavić, T. Capuder, N. Holjevac, and I. Kuzle, “Utjecaj električnih vozila na razvoj prijenosnog sustava,” in *2017 40th International Convention on Information and Communication Technology, Electronics and Microelectronics, MIPRO 2017 - Proceedings, Opatija, 2017*
- [Pub<sub>11</sub>] I. Pavić, T. Capuder, and I. Kuzle, “Fast charging stations — Power and ancillary services provision,” in *2017 IEEE Manchester PowerTech*, IEEE, Jun. 2017, pp. 1–6, ISBN: 978-1-5090-4237-1. DOI: 10.1109/PTC.2017.7981190
- [Pub<sub>12</sub>] I. Pavić, T. Capuder, I. Kuzle, and H. Pandžić, “Analiza aspekata fleksibilnosti budućeg elektroenergetskog sustava s integriranim električnim vozilima,” in *13. savjetovanje HRO CIGRÉ*, 2017, pp. 1–10
- [Pub<sub>13</sub>] M. Zidar, I. Pavić, N. Holjevac, D. Jakšić, T. Radočaj, and I. Kuzle, “Integracija infras-

strukture za punjenje električnih vozila u distribucijsku mrežu Karlovca,” in *13. savjetovanje HRO CIGRÉ*, 2017, pp. 1–8

- [Pub<sub>14</sub>] I. Pavić, T. Capuder, and H. Pandžić, “Profit margin of electric vehicle battery aggregator,” in *2018 IEEE International Energy Conference (ENERGYCON)*, IEEE, Jun. 2018, pp. 1–6, ISBN: 978-1-5386-3669-5. DOI: 10.1109/ENERGYCON.2018.8398790
- [Pub<sub>15</sub>] I. Pavić, H. Pandžić, and T. Capuder, “Electric vehicles as frequency containment reserve providers,” in *6th IEEE International Energy Conference, ENERGYCon 2020*, Institute of Electrical and Electronics Engineers Inc., Sep. 2020, pp. 911–917, ISBN: 9781728129563. DOI: 10.1109/ENERGYCon48941.2020.9236585
- [Pub<sub>16</sub>] I. Pavić, H. Pandžić, and T. Capuder, “Tight Robust Formulation for Uncertain Reserve Activation of an Electric Vehicle Aggregator,” in *2021 IEEE PowerTech*, Madrid, 2021, pp. 1–6

#### **Upcoming Conference/Under Review**

- [Pub<sub>17</sub>] I. Pavić, T. Capuder, and H. Pandžić, “Istodobni nastup na tržištima energije i rezervi - utjecaj nesigurnosti aktivacije rezerve,” in *15. savjetovanje HRO CIGRE*, 2021, p. 10



# Chapter 6

## Author's Contribution to the Publications

The results presented in this thesis through publications listed in Chapter 5 are based on the research carried out during the period of 2015-2021 at the University of Zagreb Faculty of Electrical Engineering and Computing, Unska 3, HR-10000 Zagreb, Croatia. The results are part of the following research projects:

- Title: System for Electricity Demand Management in Households (ISKON); funding: European Structural and Investment Funds
- Title: Active NeIghborhoods energy Markets pArTicipatION (Animation); funding: Croatian Science Foundation
- Title: FAcilitating Regional CROSS-border Electricity Transmission through Innovation (FARCROSS); funding: EU Horizon 2020
- Title: Big Data IT Solution for E-mobility (BigEVdata); funding: European Structural and Investment Funds
- Title: Compact City Vacuum Cleaner Development (RASCO); funding: European Structural and Investment Funds
- Title: microGrid Positioning(uGrip); funding: SmartGrids Plus ERA-Net
- Title: Electric Vehicle Battery Swapping Station (EV BASS); funding: Croatian Science Foundation
- Title: Flexible Electric Vehicle Charging Infrastructure (FlexChEV); funding: Smart-Grids ERA-Net
- Instigation of Research and Innovation Partnership on Ren. En., En. Eff. and Sust. En. Solutions for Cities (IRES-8); funding: EU-China Research and Innovation Partnership

The thesis includes 16 publications written in the collaboration with coauthors. According to the contributions, the author is listed as the leading author on all journal and most of the conference publications. The author's contributions to each paper include manuscript writing and presentation, conceptualization of the problem and solution, software implementation, development of algorithms, experimental evaluation, and interpretation of the results.

Author's contribution in specific publication is elaborated in the following list:

- [Pub<sub>1</sub>] In the journal paper entitled: "*Value of flexible electric vehicles in providing spinning reserve services*", the author: envisioned new approach of EV integration into UC models, conducted literature review, developed UC + EV MILP program in Fico Xpress environment, created future EV and Wind scenarios for sensitivity analysis, collected all necessary input data, wrote the paper and elaborated the results.
- [Pub<sub>2</sub>] In the journal paper entitled: "*Low carbon technologies as providers of operational flexibility in future power systems*", the author: upgraded existing MILP program with wind policies, conducted literature review, created future power plant decommission scenarios, collected all necessary input data, took part in writing the paper and elaboration of the results.
- [Pub<sub>3</sub>] In the journal paper entitled: "*Comprehensive Approach for Maximizing Flexibility Benefits of Electric Vehicles*", the author: envisioned new approach of fast and slow EV integration into UC models, conducted literature review, upgraded existing MILP program with fast charging stations and battery storage, collected all necessary input data, wrote the paper and elaborated the results.
- [Pub<sub>4</sub>] In the journal paper entitled: "*Electric Vehicle Based Smart E-mobility System – Definition and Comparison to the Existing Concept*", the author: envisioned new approach of EV aggregation, conducted thorough literature review, stated challenges for smart charging in CS-based system and benefits of EV-based system, developed LP program in Fico Xpress environment for energy arbitrage of EV aggregator at day-ahead energy market, collected all necessary input data, converted EV input data into adequate form, wrote the paper and proved the hypothesis through the LP model's results.
- [Pub<sub>5</sub>] In the journal paper entitled: "*Electric Vehicle Aggregator as an Automatic Reserves Provider in the European Market Setting*", the author: envisioned new approaches for reserve activation modeling (scenario-based and robust), conducted literature review, performed all statistical analyses, collected and processed all necessary input data, created stochastic models for EV aggregator market positioning, wrote the paper, elaborated the results and pinpointed the benefits of such models.
- [Pub<sub>6</sub>] In the conference paper entitled: "*Role and Impact of Coordinated EV Charging on Flexibility in Low Carbon Power Systems*", the author: incorporated fleet level EV in integer relaxed UC, collected and processed all necessary input data, visualised changes in UC under EV integration, and presented the paper in live.
- [Pub<sub>7</sub>] In the conference paper entitled: "*Defining the Role of Traditional and Low Carbon Technologies in Providing Flexibility for Future Power Systems Operation*", the author: re-designed the model EV-UC LP model to incorporate decommission policies, collected and processed all necessary input data, visualised changes under different policies, took

part in writing of the paper.

- [Pub<sub>8</sub>] In the conference paper entitled: "*Improved Grid Operation Through Power Smoothing Control Strategies Utilizing Dedicated Energy Storage at an EV Charging Station*", the author: participated in the conceptualization, took part in writing of the paper.
- [Pub<sub>9</sub>] In the conference paper entitled: "*Transportation and Power System Interdependency for Urban Fast Charging and Battery Swapping Stations in Croatia*", the author: participated in the conceptualization of the paper, was in charge for choosing the right case study location, conducted transport analysis, took part in writing of the paper.
- [Pub<sub>10</sub>] In the conference paper entitled: "*Electric Vehicle's Effect on the Transmission System Development*", the author: conceptualized the paper, conducted literature review, acquired are relevant data, wrote and presented the paper in live.
- [Pub<sub>11</sub>] In the conference paper entitled: "*Fast Charging Stations - Power and Ancillary Services Provision*", the author: conceptualized the paper, defined and created new models which incorporate both slow and fast charging in UC, research the battery storage integration into fast charging stations, conducted literature review, acquired are relevant data, wrote and presented the paper in live.
- [Pub<sub>12</sub>] In the conference paper entitled: "*Flexibility Aspects' Analysis of Future Power System with Integrated Electric Vehicles*", the author: conceptualized the paper, defined all potential charging strategies, elaborated the flexibility potential of differed strategies, wrote the paper.
- [Pub<sub>13</sub>] In the conference paper entitled: "*Integration of Electric Vehicles' Supply Equipment in Karlovac Distribution Network*", the author: participated in the conceptualization of the paper, was in charge for introduction and elaboration of the results, took part in writing of the paper.
- [Pub<sub>14</sub>] In the conference paper entitled: "*Profit Margin of Electric Vehicle Battery Aggregator*", the author: envisioned the new model for EV aggregator, conducted literature review, defined charging strategies and their flexibility services, defined different types of EV aggregators, wrote and presented the paper in live.
- [Pub<sub>15</sub>] In the conference paper entitled: "*Electric Vehicles as Frequency Containment Reserve Providers*", the author: designed new model for deterministic EV aggregator reserve bidding, implemented model in Fico Xpress, acquired all relevant input data, tested model for all scenarios, elaborated and visualized results, wrote and presented the paper online.
- [Pub<sub>16</sub>] In the conference paper entitled: "*Tight Robust Formulation for Uncertain Reserve Activation of an Electric Vehicle Aggregator*", the author: designed new model for robust EV aggregator reserve bidding, implemented model in Fico Xpress, acquired all relevant input data, conducted statistical analysis on input data, created tight robust space, tested model for all scenarios, elaborated and visualized results, wrote the paper.



# Chapter 7

## Conclusions and Future Work

The presented thesis conducted thorough research in the field of smart electric vehicle charging, on its effect on power system and on its potential to provide/sell flexibility to the power system operator. The Section 7.1 will summarize the main conclusions of the thesis, while the Section 7.2 will provide an insight in author's future research aspirations.

### 7.1 The Main Conclusions of the Thesis

The research on the e-mobility integration issues started with the detection of changes within the unit commitment caused by penetration of both EV and RES (wind). Different power system scenarios and charging strategies were developed and tested. This in-detail modeling and analysis approach resulted with several important conclusions in EV-power system integration topic applicable for wide range of existing power systems. First of all, uncontrolled EV charging should be rigorously avoided as it increases costs and emissions compared to the systems without EVs. On the other hand, it is clear that controlled EV charging strategies, even without discharging and/or reserve provision capabilities, decrease overall system cost and wind curtailment and. V2G and reserve provision capabilities add additional new flexibility to the power system and the reserve provision shifts from coal and gas plants to EVs. Decommission of coal and nuclear power plants shows that the system becomes more flexible (decreased wind curtailment), but it is also accompanied with increased flexibility provision from expensive gas units (increased total cost). Here, the EVs flexibility potential stands out even more. When both EVs and wind are able to provide reserves, the system always choose EVs as it means lower wind curtailment rates. Fast EV charging can be extremely harmful to the power system as the powers drawn from the grid are very high. The results shows that there are two option to mitigate those issues: integration of stationary storage within charging stations or usage of slow charging flexibility to balance it.

The intermediate step of thesis research was based on the identifying the right strategy for



EV aggregation. The charging station based concept observes the EVs only when connected to a specific charging station. The EV based concept observes EVs wherever they drive or charge and thus can result with higher flexibility potential and higher revenues. While the thesis does a nice job into identification of the issue, it surely cannot steer the overall e-mobility into that direction. However, it can be a first small step towards new system organisation.

The last part of the thesis deals with the challenges of accurate EV energy plus reserve market modeling exposed to reserve activation uncertainty. This issue was, so far, not solved in the scientific community. The results first demonstrated how neglecting reserve activation can push EVs into infeasible states. Next it provided the solution in both stochastic and robust uncertainty modelling. Even though both of those can be utilized, the results shows that the robust modeling is better for the challenge-at-hand. The results also demonstrated how the robust subspace can be efficiently tailored around the historic dataset to provide the better ratio between conservativeness and risking.

## 7.2 Further Research Directions

The proposed robust modeling of reserve activation is a great way how to deal with activation uncertainty but additional research can be carried out to lower the overall conservativeness of the approach. Two research directions are open: adaptive robust and distributionally robust optimization. The former direction opens the robust model for subsequent trading stages which loosens strict obligations to stay feasible in the day-ahead stage only. It also creates more in-between market arbitrage possibilities. The latter direction is a followup on the detail analysis of the historic reserve activation data. It can be utilized to tailor the robust subspace on the probability density functions occurring through those historic data. Similarly to stochastic modelling, this approach takes into account probability of occurrence and not only the worst case.

Also, the last part of the thesis dealt with modeling of the volume of the reserve activation, however, the reserve activation price is also an interesting and insufficiently researched area. Detail analysis of the price formation can be researched and as well as the potential to apply the robust approach for the price uncertainty as well.

# Bibliography

- [1] W. R. Institute, *World Greenhouse Gas Emissions: 2016*, <https://www.wri.org/resources/data-visualizations/world-greenhouse-gas-emissions-2016>.
- [2] BP, “Statistical Review of World Energy, 2020 | 69th Edition,” BP, Tech. Rep., 2020, p. 66.
- [3] H. Ritchie, *Energy mix - Our World in Data*, <https://ourworldindata.org/energy-mix>.
- [4] H. Ritchie, *Electricity Mix - Our World in Data*, <https://ourworldindata.org/electricity-mix>.
- [5] I. E. Agency, *World Energy Outlook 2020*, <https://www.iea.org/reports/world-energy-outlook-2020>, 2020.
- [6] Fraunhofer, *Electricity generation pie charts | Energy charts*, <https://energy-charts.info/charts/energy>.
- [7] International Energy Agency, *Status of Power System Transformation 2019: Power system flexibility*, 2019.
- [8] J. Cochran, M. Miller, O. Zinaman, M. Milligan, D. Arent, B. Palmintier, M. O'Malley, U. College Dublin, S. Mueller, I. Energy Agency, E. Lannoye, A. Tuohy, B. Kujala, N. Power, C. Council, M. Sommer, H. Holttinen, J. Kiviluoma, V. Technical Research Centre of Finland, S. Soonee, and P. System Operation Corporation, “Flexibility in 21st Century Power Systems,” NREL, Tech. Rep., 2014.
- [9] Emanuele Taibi, Thomas Nikolakakis, Laura Gutierrez, Carlos Fernandez, Juha Kiviluoma, Tomi J. Lindroos, and Simo Rissanen, “Power system flexibility for the energy transition,” International Renewable Energy Agency, Tech. Rep., 2018.
- [10] U.S. Energy Information Administration, *Electric Power Monthly - U.S. Energy Information Administration (EIA)*, [https://www.eia.gov/electricity/monthly/epm\\_table\\_grapher.php?t=](https://www.eia.gov/electricity/monthly/epm_table_grapher.php?t=)
- [11] ENTSO-E, “ENTSO-E Market Report 2020,” ENTSO-E, Tech. Rep., 2020.
- [12] THE EUROPEAN COMMISSION, *COMMISSION REGULATION (EU) 2015/1222 of 24 July 2015 establishing a guideline on capacity allocation and congestion management*, 2015.

- [13] THE EUROPEAN PARLIAMENT and THE COUNCIL OF THE EUROPEAN UNION, *DIRECTIVE (EU) 2019/944 OF THE EUROPEAN PARLIAMENT AND OF THE COUNCIL of 5 June 2019 on common rules for the internal market for electricity and amending Directive 2012/27/EU*, 2019.
- [14] THE EUROPEAN PARLIAMENT and THE COUNCIL OF THE EUROPEAN UNION, *REGULATION (EU) 2019/943 OF THE EUROPEAN PARLIAMENT AND OF THE COUNCIL of 5 June 2019 on the internal market for electricity*, 2019.
- [15] ENTSO-E, “Electricity Balancing in Europe,” ENTSO-E, Bruxelles, Tech. Rep., 2018.
- [16] ENTSO-E, “Balancing Report 2020,” ENTSO-E, Bruxelles, Tech. Rep., 2020.
- [17] THE EUROPEAN COMMISSION, *COMMISSION REGULATION (EU) 2017/2195 of 23 November 2017 establishing a guideline on electricity balancing*, 2017.
- [18] THE EUROPEAN COMMISSION, *COMMISSION REGULATION (EU) 2017/1485 of 2 August 2017 establishing a guideline on electricity transmission system operation*, Bruxelles, 2017.
- [19] ENTSO-E, “OPERATIONAL RESERVE AD HOC TEAM REPORT FINAL VERSION,” ENTSO-E, Brussels, Tech. Rep., 2012.
- [20] Entso-e, “Supporting Document for the Network Code on Load-Frequency Control and Reserves,” Entso-e, Tech. Rep., 2013.
- [21] Rambøll Danmark, “Ancillary Services From New Technologies Technical Potentials and Market Integration,” Rambøll Danmark, Tech. Rep. December, 2019.
- [22] SWECO, ECOFYS, TRACTABEL, and ECOFYS, “Study on the effective integration of Distributed Energy Resources for providing flexibility to the electricity system,” SWECO ECOFYS TRACTABEL ECOFYS, Tech. Rep. April, 2015.
- [23] IEA (International Energy Agency), “Global EV Outlook 2018,” IEA, Tech. Rep., 2018. DOI: 10.1787/9789264302365-en.
- [24] Energy BrainBlog, *E-Mobility in Germany (III): Players at the charging station*.
- [25] Netherlands Enterprise Agency, “Electric vehicle charging: Definitions and explanation,” Tech. Rep. January, 2019, p. 12.
- [26] F.-X. CHARBONNIER, B. GRANDJEAN, and T. RÖHR, “Part C – Charging infrastructure analysis,” Tech. Rep., 2015, p. 35.
- [27] O. Paturet, “SUB-GROUP TO FOSTER THE CREATION OF AN ELECTROMOBILITY MARKET OF SERVICES (SGEMS) Draft-Final Report,” European Commission, Tech. Rep., 2017.

- [28] European Network of Transmission System Operators (ENTSO), “ENTSO-E’s Statistical Factsheet 2018,” *Entso-E*, no. April, pp. 1–8, 2019.
- [29] International Energy Agency (IEA), “Electricity Information: Overview 2019,” *Statistics IEA*, pp. 1–10, 2019.
- [30] E. Paffumi, M. De Gennaro, and G. Martini, “European-wide study on big data for supporting road transport policy,” *Case Studies on Transport Policy*, vol. 6, no. 4, pp. 785–802, Dec. 2018, ISSN: 22136258. DOI: 10.1016/j.cstp.2018.10.001.
- [31] EV-Volumes, *The Electric Vehicle World Sales Database*, <https://www.ev-volumes.com/>.
- [32] Ioannis Tsiropoulos, Dalius Tarvydas, and Natalia Lebedeva, “Li-ion batteries for mobility and stationary storage applications - Scenarios for costs and market growth,” JRC, Tech. Rep., 2018. DOI: 10.2760/8717.
- [33] Mobility Foresights, “Global Electric Vehicle On Board Charger Market 2021-2026,” Mobility Research Report, Tech. Rep., 2020, pp. 1–104.
- [34] I. Laicane, D. Blumberga, A. Blumberga, and M. Rosa, “Evaluation of Household Electricity Savings. Analysis of Household Electricity Demand Profile and User Activities,” in *Energy Procedia*, vol. 72, Elsevier Ltd, Jun. 2015, pp. 285–292. DOI: 10.1016/j.egypro.2015.06.041.
- [35] EV Database, *Energy consumption of full electric vehicles cheatsheet - EV Database*, <https://ev-database.org/cheatsheet/energy-consumption-electric-car>.
- [36] G. Pasaoglu, D. Fiorello, A. Martino, G. Scarcella, A. Alemanno, A. Zubaryeva, C. Thiel, and L. P. O. o. t. E. Union, “Driving and parking patterns of European car drivers - a mobility survey,” JRC, Tech. Rep., 2012, p. 112. DOI: doi : 10.2790/7028.
- [37] A. Klettke and A. Mose, “Effect of electromobility on the power system and the integration of RES,” Metis, Tech. Rep. June, 2018, pp. 1–54.
- [38] International Renewable Energy Agency, “ELECTRIC-VEHICLE SMART CHARGING INNOVATION LANDSCAPE BRIEF,” IRENA, Tech. Rep., 2019.
- [39] D. G. Luenberger and Y. Ye, *Linear and nonlinear programming*, 4th ed., C. Springer, 1973, vol. 98, pp. 109–148. DOI: 10.1016/S0076-5392(08)62009-3.
- [40] U. M. Diwekar, *Introduction to Applied Optimization*, ser. Applied Optimization. Boston, MA: Springer US, 2003, vol. 80, ISBN: 978-1-4757-3747-9. DOI: 10.1007/978-1-4757-3745-5.

- [41] B. Li, X. Wang, M. Shahidehpour, C. Jiang, and Z. Li, “Robust Bidding Strategy and Profit Allocation for Cooperative DSR Aggregators with Correlated Wind Power Generation,” *IEEE Transactions on Sustainable Energy*, vol. 10, no. 4, pp. 1904–1915, Oct. 2019, ISSN: 19493037. DOI: 10.1109/TSTE.2018.2875483.
- [42] S. P. Bradley, A. C. Hax, and T. L. Magnanti, *Applied Mathematical Programming*. Addison-Wesley Publishing Company, 1977.
- [43] A. J. Conejo and L. Baringo, *Unit Commitment and Economic Dispatch*. Springer, Cham, 2018, pp. 197–232. DOI: 10.1007/978-3-319-69407-8\_7.
- [44] H. Pandzic, T. Qiu, and D. S. Kirschen, “Comparison of state-of-the-art transmission constrained unit commitment formulations,” in *IEEE Power and Energy Society General Meeting*, 2013, ISBN: 9781479913039. DOI: 10.1109/PESMG.2013.6672719.
- [45] M. Carrión and J. M. Arroyo, “A computationally efficient mixed-integer linear formulation for the thermal unit commitment problem,” *IEEE Transactions on Power Systems*, vol. 21, no. 3, pp. 1371–1378, Aug. 2006, ISSN: 08858950. DOI: 10.1109/TPWRS.2006.876672.
- [46] M. Aunedi, P. Aristidis Kountouriotis, J. E. Ortega Calderon, D. Angeli, and G. Strbac, “Economic and environmental benefits of dynamic demand in providing frequency regulation,” *IEEE Transactions on Smart Grid*, vol. 4, no. 4, pp. 2036–2048, Dec. 2013, ISSN: 19493053. DOI: 10.1109/TSG.2013.2258047.
- [47] B. S. Palmintier and M. D. Webster, “Heterogeneous unit clustering for efficient operational flexibility modeling,” *IEEE Transactions on Power Systems*, vol. 29, no. 3, pp. 1089–1098, 2014, ISSN: 08858950. DOI: 10.1109/TPWRS.2013.2293127.
- [48] L. Zhang, T. Capuder, and P. Mancarella, “Unified Unit Commitment Formulation and Fast Multi-Service LP Model for Flexibility Evaluation in Sustainable Power Systems,” *IEEE Transactions on Sustainable Energy*, vol. 7, no. 2, pp. 658–671, Apr. 2016, ISSN: 19493029. DOI: 10.1109/TSTE.2015.2497411.
- [49] A. Rabiee, B. Mohammadi-Ivatloo, and M. Moradi-Dalvand, “Fast dynamic economic power dispatch problems solution via optimality condition decomposition,” *IEEE Transactions on Power Systems*, vol. 29, no. 2, pp. 982–983, Mar. 2014, ISSN: 08858950. DOI: 10.1109/TPWRS.2013.2288028.
- [50] A. Nasri, S. J. Kazempour, A. J. Conejo, and M. Ghandhari, “Network-constrained AC unit commitment under uncertainty: A benders’ decomposition approach,” *IEEE Transactions on Power Systems*, vol. 31, no. 1, pp. 412–422, Jan. 2016, ISSN: 08858950. DOI: 10.1109/TPWRS.2015.2409198.

- [51] W. R. Barcelo and P. Rastgoufard, "Dynamic economic dispatch using the extended security constrained economic dispatch algorithm," *IEEE Transactions on Power Systems*, vol. 12, no. 2, pp. 961–967, 1997, ISSN: 08858950. DOI: 10.1109/59.589791.
- [52] Y. Chen, F. Liu, B. Liu, W. Wei, and S. Mei, "An Efficient MILP Approximation for the Hydro-Thermal Unit Commitment," *IEEE Transactions on Power Systems*, vol. 31, no. 4, pp. 3318–3319, Jul. 2016, ISSN: 08858950. DOI: 10.1109/TPWRS.2015.2479397.
- [53] I. Blanco and J. M. Morales, "An Efficient Robust Solution to the Two-Stage Stochastic Unit Commitment Problem," *IEEE Transactions on Power Systems*, vol. 32, no. 6, pp. 4477–4488, Nov. 2017, ISSN: 08858950. DOI: 10.1109/TPWRS.2017.2683263. arXiv: 1606.06014.
- [54] B. Lu and M. Shahidehpour, "Unit commitment with flexible generating units," *IEEE Transactions on Power Systems*, vol. 20, no. 2, pp. 1022–1034, May 2005, ISSN: 08858950. DOI: 10.1109/TPWRS.2004.840411.
- [55] M. Polson and V. Sokolov, "Deep learning for energy markets," *Applied Stochastic Models in Business and Industry*, vol. 36, no. 1, pp. 195–209, 2020, ISSN: 15264025. DOI: 10.1002/asmb.2518. arXiv: 1808.05527.
- [56] L. Wang, Z. Zhang, and J. Chen, "Short-Term Electricity Price Forecasting with Stacked Denoising Autoencoders," *IEEE Transactions on Power Systems*, vol. 32, no. 4, pp. 2673–2681, 2017, ISSN: 08858950. DOI: 10.1109/TPWRS.2016.2628873.
- [57] M. K. Kim, "A new approach to short-term price forecast strategy with an artificial neural network approach: Application to the Nord Pool," *Journal of Electrical Engineering and Technology*, vol. 10, no. 4, pp. 1480–1491, 2015, ISSN: 20937423. DOI: 10.5370/JEET.2015.10.4.1480.
- [58] A. Lucas, K. Pegios, E. Kotsakis, and D. Clarke, "Price forecasting for the balancing energy market using machine-learning regression," *Energies*, vol. 13, no. 20, pp. 1–16, 2020, ISSN: 19961073. DOI: 10.3390/en13205420.
- [59] M. Merten, F. Rücker, I. Schoeneberger, and D. U. Sauer, "Automatic frequency restoration reserve market prediction: Methodology and comparison of various approaches," *Applied Energy*, vol. 268, no. May, p. 114978, 2020, ISSN: 03062619. DOI: 10.1016/j.apenergy.2020.114978.

- [60] S. E. Fleten and E. Pettersen, "Constructing bidding curves for a price-taking retailer in the Norwegian electricity market," *IEEE Transactions on Power Systems*, vol. 20, no. 2, pp. 701–708, May 2005, ISSN: 08858950. DOI: 10.1109/TPWRS.2005.846082.
- [61] N. Mazzi, J. Kazempour, and P. Pinson, "Price-Taker Offering Strategy in Electricity Pay-as-Bid Markets," *IEEE Transactions on Power Systems*, vol. 33, no. 2, pp. 2175–2183, Mar. 2018, ISSN: 08858950. DOI: 10.1109/TPWRS.2017.2737322.
- [62] A. J. Conejo, F. J. Nogales, and J. M. Arroyo, "Price-taker bidding strategy under price uncertainty," *IEEE Transactions on Power Systems*, vol. 17, no. 4, pp. 1081–1088, Nov. 2002, ISSN: 08858950. DOI: 10.1109/TPWRS.2002.804948.
- [63] I. Pavic, Y. Dvorkin, and H. Pandžić, "Energy and reserve co-optimisation - Reserve availability, lost opportunity and uplift compensation cost," *IET Generation, Transmission and Distribution*, vol. 13, no. 2, 2019, ISSN: 17518687. DOI: 10.1049/iet-gtd.2018.5480.
- [64] K. Pandžić, I. Pavić, I. Andročec, and H. Pandžić, "Optimal Battery Storage Participation in European Energy and Reserves Markets," *Energies*, vol. 13, no. 24, p. 6629, Dec. 2020. DOI: 10.3390/EN13246629.
- [65] S. Wogrin, E. Centeno, and J. Barquín, "Generation capacity expansion in liberalized electricity markets: A stochastic MPEC approach," *IEEE Transactions on Power Systems*, vol. 26, no. 4, pp. 2526–2532, Nov. 2011, ISSN: 08858950. DOI: 10.1109/TPWRS.2011.2138728.
- [66] L. Baringo and A. J. Conejo, "Strategic offering for a wind power producer," *IEEE Transactions on Power Systems*, vol. 28, no. 4, pp. 4645–4654, 2013, ISSN: 08858950. DOI: 10.1109/TPWRS.2013.2273276.
- [67] M. Yazdani-Damavandi, N. Neyestani, M. Shafie-khah, J. Contreras, and J. P. S. Catalao, "Strategic Behavior of Multi-Energy Players in Electricity Markets as Aggregators of Demand Side Resources Using a Bi-Level Approach," *IEEE Transactions on Power Systems*, vol. 33, no. 1, pp. 397–411, Mar. 2017, ISSN: 0885-8950. DOI: 10.1109/tpwrs.2017.2688344.
- [68] H. Ding, P. Pinson, Z. Hu, J. Wang, and Y. Song, "Optimal Offering and Operating Strategy for a Large Wind-Storage System as a Price Maker," *IEEE Transactions on Power Systems*, vol. 32, no. 6, pp. 4904–4913, Nov. 2017, ISSN: 08858950. DOI: 10.1109/TPWRS.2017.2681720.

- [69] H. M. Pousinho, J. Contreras, A. G. Bakirtzis, and J. P. Catalão, “Risk-constrained scheduling and offering strategies of a price-maker hydro producer under uncertainty,” *IEEE Transactions on Power Systems*, vol. 28, no. 2, pp. 1879–1887, 2013, ISSN: 08858950. DOI: 10.1109/TPWRS.2012.2229473.
- [70] M. Zugno, J. M. Morales, P. Pinson, and H. Madsen, “Pool strategy of a price-maker wind power producer,” *IEEE Transactions on Power Systems*, vol. 28, no. 3, pp. 3440–3450, 2013, ISSN: 08858950. DOI: 10.1109/TPWRS.2013.2252633.
- [71] A. A. De La Nieta, J. Contreras, J. I. Munoz, and M. O’Malley, “Modeling the impact of a wind power producer as a price-maker,” *IEEE Transactions on Power Systems*, vol. 29, no. 6, pp. 2723–2732, Nov. 2014, ISSN: 08858950. DOI: 10.1109/TPWRS.2014.2313960.
- [72] M. Song and M. Amelin, “Price-Maker Bidding in Day-Ahead Electricity Market for a Retailer with Flexible Demands,” *IEEE Transactions on Power Systems*, vol. 33, no. 2, pp. 1948–1958, Mar. 2018, ISSN: 08858950. DOI: 10.1109/TPWRS.2017.2741000.
- [73] A. J. Conejo, M. Carrión, and J. M. Morales, *Decision Making Under Uncertainty in Electricity Markets*, ser. International Series in Operations Research & Management Science. Boston, MA: Springer US, 2010, vol. 153, ISBN: 978-1-4419-7420-4. DOI: 10.1007/978-1-4419-7421-1.
- [74] J. M. Morales, A. J. Conejo, H. Madsen, P. Pinson, and M. Zugno, *Integrating Renewables in Electricity Markets Operational Problems*. Springer, 2010, vol. 139, pp. 1–+, ISBN: 0884-8289.
- [75] G. Cornuéjols, J. Peña, and R. Tütüncü, “Multi-stage stochastic programming,” in *Optimization Methods in Finance*, 2nd ed. Cambridge University Press, 2018, pp. 248–261. DOI: 10.1017/9781107297340.017.
- [76] D. Bertsimas, S. Shtern, and B. Sturt, “A data-driven approach to multi-stage stochastic linear optimization,” Tech. Rep.
- [77] H. Bakker, F. Dunke, and S. Nickel, “A structuring review on multi-stage optimization under uncertainty: Aligning concepts from theory and practice,” *Omega (United Kingdom)*, vol. 96, p. 102 080, Oct. 2020, ISSN: 03050483. DOI: 10.1016/j.omega.2019.06.006.
- [78] N. V. Sahinidis, “Optimization under uncertainty: State-of-the-art and opportunities,” *Computers and Chemical Engineering*, vol. 28, no. 6-7, pp. 971–983, 2004, ISSN: 00981354. DOI: 10.1016/j.compchemeng.2003.09.017.



- [79] G. B. Dantzig, "Linear Programming under Uncertainty," *Management Science*, vol. 1, no. 3-4, pp. 197–206, Apr. 1955, ISSN: 0025-1909. DOI: 10.1287/mnsc.1.3-4.197.
- [80] J. R. Birge, "Stochastic programming computation and applications," *INFORMS Journal on Computing*, vol. 9, no. 2, pp. 111–133, May 1997, ISSN: 10919856. DOI: 10.1287/ijoc.9.2.111.
- [81] P. Kall and J. Mayer, *Stochastic Linear Programming*, ser. International Series in Operations Research & Management Science. Boston, MA: Springer US, 2011, vol. 156, ISBN: 978-1-4419-7728-1. DOI: 10.1007/978-1-4419-7729-8.
- [82] J. R. Birge and F. Louveaux, *Introduction to Stochastic Programming*, ser. Springer Series in Operations Research and Financial Engineering. New York, NY: Springer New York, 2011, ISBN: 978-1-4614-0236-7. DOI: 10.1007/978-1-4614-0237-4.
- [83] F. J. Heredia, M. J. Rider, and C. Corchero, "Optimal bidding strategies for thermal and generic programming units in the day-ahead electricity market," *IEEE Transactions on Power Systems*, vol. 25, no. 3, pp. 1504–1518, Aug. 2010, ISSN: 08858950. DOI: 10.1109/TPWRS.2009.2038269.
- [84] H. Wu and M. Shahidehpour, "Stochastic SCUC solution with variable wind energy using constrained ordinal optimization," *IEEE Transactions on Sustainable Energy*, vol. 5, no. 2, pp. 379–388, 2014, ISSN: 19493029. DOI: 10.1109/TSTE.2013.2289853.
- [85] P. Chen, P. Siano, B. Bak-Jensen, and Z. Chen, "Stochastic optimization of wind turbine power factor using stochastic model of wind power," *IEEE Transactions on Sustainable Energy*, vol. 1, no. 1, pp. 19–29, 2010, ISSN: 19493029. DOI: 10.1109/TSTE.2010.2044900.
- [86] J. Xu, X. Yi, Y. Sun, T. Lan, and H. Sun, "Stochastic Optimal Scheduling Based on Scenario Analysis for Wind Farms," *IEEE Transactions on Sustainable Energy*, vol. 8, no. 4, pp. 1548–1559, Oct. 2017, ISSN: 19493029. DOI: 10.1109/TSTE.2017.2694882.
- [87] C. Sahin, M. Shahidehpour, and I. Erkmén, "Allocation of hourly reserve versus demand response for security-constrained scheduling of stochastic wind energy," *IEEE Transactions on Sustainable Energy*, vol. 4, no. 1, pp. 219–228, 2013, ISSN: 19493029. DOI: 10.1109/TSTE.2012.2213849.
- [88] J. Duchi, "Optimization with uncertain data," Tech. Rep., 2018.
- [89] A. Ben-Tal, L. El Ghaoui, and A. Nemirovski, *Robust Optimization*. Princeton University Press, Aug. 2009, ISBN: 9781400831050. DOI: 10.1515/9781400831050.

- [90] D. Bertsimas and A. Thiele, “Robust and Data-Driven Optimization: Modern Decision-Making Under Uncertainty,” Tech. Rep., 2006.
- [91] D. Bertsimas and M. Sim, “The price of robustness,” *Operations Research*, vol. 52, no. 1, pp. 35–53, Jan. 2004, ISSN: 0030364X. DOI: 10.1287/opre.1030.0065.
- [92] M. Goerigk and A. Schöbel, “Algorithm engineering in robust optimization,” in *Lecture Notes in Computer Science (including subseries Lecture Notes in Artificial Intelligence and Lecture Notes in Bioinformatics)*, vol. 9220 LNCS, Springer Verlag, Nov. 2016, pp. 245–279. DOI: 10.1007/978-3-319-49487-6\_8. arXiv: 1505.04901.
- [93] B. L. Gorissen, I. Yanikoglu, and D. den Hertog, “A practical guide to robust optimization,” *Omega (United Kingdom)*, vol. 53, pp. 124–137, Jun. 2015, ISSN: 03050483. DOI: 10.1016/j.omega.2014.12.006. arXiv: 1501.02634.
- [94] A. J. Conejo, E. Castillo, and R. M. R. García-bertrand, *Decomposition Techniques in Mathematical Programming*. Springer, Cham, 2006, ISBN: 9783540276852. DOI: 10.1007/3-540-27686-6.
- [95] R. Chen, H. Sun, Q. Guo, Z. Li, T. Deng, W. Wu, and B. Zhang, “Reducing Generation Uncertainty by Integrating CSP with Wind Power: An Adaptive Robust Optimization-Based Analysis,” *IEEE Transactions on Sustainable Energy*, vol. 6, no. 2, pp. 583–594, Apr. 2015, ISSN: 19493029. DOI: 10.1109/TSTE.2015.2396971.
- [96] Z. Li, W. Wu, M. Shahidehpour, and B. Zhang, “Adaptive Robust Tie-Line Scheduling Considering Wind Power Uncertainty for Interconnected Power Systems,” *IEEE Transactions on Power Systems*, vol. 31, no. 4, pp. 2701–2713, Jul. 2016, ISSN: 08858950. DOI: 10.1109/TPWRS.2015.2466546.
- [97] M. Rahimiyan and L. Baringo, “Strategic Bidding for a Virtual Power Plant in the Day-Ahead and Real-Time Markets: A Price-Taker Robust Optimization Approach,” *IEEE Transactions on Power Systems*, vol. 31, no. 4, pp. 2676–2687, Jul. 2016, ISSN: 08858950. DOI: 10.1109/TPWRS.2015.2483781.
- [98] A. A. Thatte, L. Xie, D. E. Viassolo, and S. Singh, “Risk measure based robust bidding strategy for arbitrage using a wind farm and energy storage,” *IEEE Transactions on Smart Grid*, vol. 4, no. 4, pp. 2191–2199, Dec. 2013, ISSN: 19493053. DOI: 10.1109/TSG.2013.2271283.
- [99] W. Wei, F. Liu, and S. Mei, “Distributionally robust Co-optimization of energy and reserve dispatch,” *IEEE Transactions on Sustainable Energy*, vol. 7, no. 1, pp. 289–300, Jan. 2016, ISSN: 19493029. DOI: 10.1109/TSTE.2015.2494010.

- [100] Y. Guo, K. Baker, E. Dallanese, Z. Hu, and T. H. Summers, “Data-based distributionally robust stochastic optimal power flow - Part I: Methodologies,” *IEEE Transactions on Power Systems*, vol. 34, no. 2, pp. 1483–1492, Mar. 2019, ISSN: 08858950. DOI: 10.1109/TPWRS.2018.2878385. arXiv: 1804.06388.
- [101] Y. Guo, K. Baker, E. Dallanese, Z. Hu, and T. H. Summers, “Data-based distributionally robust stochastic optimal power flow - Part II: Case studies,” *IEEE Transactions on Power Systems*, vol. 34, no. 2, pp. 1493–1503, Mar. 2019, ISSN: 08858950. DOI: 10.1109/TPWRS.2018.2878380.
- [102] Y. Zhou, M. Shahidehpour, Z. Wei, Z. Li, G. Sun, and S. Chen, “Distributionally Robust Unit Commitment in Coordinated Electricity and District Heating Networks,” *IEEE Transactions on Power Systems*, vol. 35, no. 3, pp. 2155–2166, May 2020, ISSN: 15580679. DOI: 10.1109/TPWRS.2019.2950987.
- [103] A. Velloso, A. Street, D. Pozo, J. M. Arroyo, and N. G. Cobos, “Two-stage robust unit commitment for co-optimized electricity markets: An adaptive data-driven approach for scenario-based uncertainty sets,” *IEEE Transactions on Sustainable Energy*, vol. 11, no. 2, pp. 958–969, Apr. 2020, ISSN: 19493037. DOI: 10.1109/TSTE.2019.2915049. arXiv: 1803.06676.
- [104] Q. Wang, J. Wang, and Y. Guan, “Wind power bidding based on chance-constrained optimization,” in *IEEE Power and Energy Society General Meeting*, 2011, ISBN: 9781457710018. DOI: 10.1109/PES.2011.6039433.
- [105] G. Dorini, P. Pinson, and H. Madsen, “Chance-constrained optimization of demand response to price signals,” *IEEE Transactions on Smart Grid*, vol. 4, no. 4, pp. 2072–2080, Dec. 2013, ISSN: 19493053. DOI: 10.1109/TSG.2013.2258412.
- [106] Z. Liu, Q. Wu, S. S. Oren, S. Huang, R. Li, and L. Cheng, “Distribution locational marginal pricing for optimal electric vehicle charging through chance constrained mixed-integer programming,” *IEEE Transactions on Smart Grid*, vol. 9, no. 2, pp. 644–654, 2018, ISSN: 19493053. DOI: 10.1109/TSG.2016.2559579.

# Abbreviations

aFRR	automatic Frequency Restoration Reserve
BRP	Balance Responsible Party
BSP	Balancing Service Provider
CP	Charging Point
CPO	Charging Point Operator
DA	Day-Ahead
DER	Distributed Energy Resource
DSO	Distribution System Operator
ED	Economic Dispatch
EMP	E-Mobility Provider
EV	Electric Vehicle
FACTS	Flexible Alternating Current Transmission Systems
FCR	Frequency Containment Reserve
GHG	Green-House Gas
ICE	Internal Combustion Engine
ID	IntraDay
IP	Integer Program
ISO	Independent System Operator
ISP	Imbalance Settlement Price
LMP	Locational Marginal Price
LP	Linear Program
mFRR	manual Frequency Restoration Reserve
MILP	Mixed Integer Linear Program
MPEC	Mathematical Program with Equilibrium Constraints
NCUC	Network Constrained Unit Commitment
not-RES	Not Renewable Energy Sources
OBC	On-Board-Charger
OF	Objective Function
OR	Operations Research
RES	Renewable Energy Sources

Abbreviations

---

- RR . . . . . Replacement Reserve
- RTO . . . . . Regional Transmission Organisation
  
- SDP . . . . . Semi-Definite Program
- SOC . . . . . State-Of-Charge
- STEPS . . . . . Stated Policies Scenario
  
- TSO . . . . . Transmission System Operator
  
- UC . . . . . Unit Commitment

# Publications

There are in total 5 journal papers (4 published and 1 under review) and 11 conference papers (15 presented and 1 under review) under this thesis. All (5) journal papers are attached bellow. When it comes to the conferences, due to the brevity of the thesis, only international conferences of high significance in power system community are attached (6).

## Journal Papers

### Published

- [Pub1] I. Pavić, T. Capuder, and I. Kuzle, “Value of flexible electric vehicles in providing spinning reserve services,” *Applied Energy*, vol. 157, pp. 60–74, Nov. 2015, ISSN: 03062619. DOI: 10.1016/j.apenergy.2015.07.070.
- [Pub2] I. Pavić, T. Capuder, and I. Kuzle, “Low carbon technologies as providers of operational flexibility in future power systems,” *Applied Energy*, vol. 168, pp. 724–738, Apr. 2016, ISSN: 0306-2619. DOI: 10.1016/J.APENERGY.2016.01.123.
- [Pub3] I. Pavić, T. Capuder, and I. Kuzle, “A Comprehensive Approach for Maximizing Flexibility Benefits of Electric Vehicles,” *IEEE Systems Journal*, pp. 1–12, 2017, ISSN: 1932-8184. DOI: 10.1109/JSYST.2017.2730234.
- [Pub4] I. Pavić, H. Pandžić, and T. Capuder, “Electric vehicle based smart e-mobility system – Definition and comparison to the existing concept,” *Applied Energy*, vol. 272, p. 115 153, Aug. 2020, ISSN: 03062619. DOI: 10.1016/j.apenergy.2020.115153.

### Early Access/Under Review

- [Pub5] I. Pavić, H. Pandžić, and T. Capuder, “Electric Vehicle Aggregator as an Automatic Reserves Provider in the European Market Setting,” *IEEE Transactions on Power System*, vol. Under review, pp. 1–8, 2020. arXiv: 2012.11158.



### **Publication 1**

I. Pavić, T. Capuder, and I. Kuzle, “Value of flexible electric vehicles in providing spinning reserve services,” *Applied Energy*, vol. 157, pp. 60–74, Nov. 2015, ISSN: 03062619. DOI: 10.1016/j.apenergy.2015.07.070



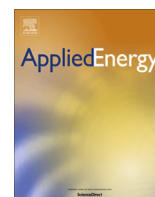

# Value of flexible electric vehicles in providing spinning reserve services



Ivan Pavić\*, Tomislav Capuder, Igor Kuzle

University of Zagreb Faculty of Electrical Engineering and Computing, Croatia

## HIGHLIGHTS

- Mixed integer linear programming model for provision of multiple services from electric vehicles.
- Flexibility benefits of electric vehicles in provision of spinning reserve and energy.
- Impact of different electric vehicles charging strategies on electric power system operation.
- Assessment of environmental and economic benefits under different energy mix scenarios.
- Assessment of wind curtailment reduction under different energy mix scenarios.

## ARTICLE INFO

### Article history:

Received 2 June 2015

Received in revised form 13 July 2015

Accepted 25 July 2015

### Keywords:

Ancillary services

Electric vehicles (EV)

Flexibility

Mixed integer linear programming (MILP)

Renewable energy sources (RES)

Spinning reserve

## ABSTRACT

As the share of integrated renewable energy sources (RES) increases, traditional operation principles of the power systems need to change in order to maintain reliable and secure service provision, on one hand, and minimal cost and environmentally friendly electricity generation on the other. The challenge of alleviating additional uncertainty and variability brought by new sources to the system operation is seen as defining both flexibility capacities and flexibility requirements through provision of multiple services. In this context the role of emerging technologies, such as electric vehicles (EV) and energy storage (ES), is recognized through their active participation in providing both energy and reserve service.

This paper elaborates on the benefits of active EV participation in multiple system services through various charging strategies. The presented mixed integer linear programming (MILP) unit commitment problem (UC) considers the capability of EV to provide primary, secondary and tertiary reserve as well as energy, however the focus is put on the benefits of EV providing spinning reserve services. The results clearly show benefits of multiple EV role to that of providing energy only. In addition the paper analyses multiple power systems, with regards to their energy mix, and recognizes how integration of EVs reflects on power system flexibility through metrics expressed as operational cost, environmental benefits and reduced wind curtailment.

© 2015 Elsevier Ltd. All rights reserved.

## 1. Introduction

Electric power systems are experiencing tremendous transformation over the past few decades as the introduction of new low carbon technologies (LCT) brings changes in economic, environmental and regulatory aspects. One of key challenges in power systems today is the integration of renewable energy sources (RES) which are at the same time creating benefits to national energy policies (energy security, independence on import oil and gas), national economy (new jobs in rural communities) and to human health (decrease of greenhouse gas emissions and waste), but are also creating additional uncertainty and variability and challenging traditional principles of maintaining generation and consumption

equilibrium. To compensate these imbalances the system operator is compelled to have enough reserve in every moment, meaning that the system must have enough flexibility. These services are provided by controllable, generating units through ancillary services forcing traditional fossil fuel based generators to operate in non-optimal working states, sometimes resulting in the overall operation cost and emissions increase despite the integration of clean energy sources [1,2].

With the uptake of LCT, new concepts for providing systems flexibility are emerging where both interconnections to other, more flexible power systems, or integration of new market participants, such as energy storage (ES), electric vehicles (EV) and multi-energy concepts [3], will change the paradigm of how low carbon power systems operate. Advancements in the field of energy storage technologies, improving their performance and reducing their investment cost, are making them a relevant future

\* Corresponding author.

E-mail address: [ivan.pavic@fer.hr](mailto:ivan.pavic@fer.hr) (I. Pavić).

## Nomenclature

### Decision variables

$p_{t,i}^{g-TP}$	thermal units generation
$p_{t,i}^{g-HP}$	hydro units generation
$p_{t,i}^{g-PS}, p_{t,i}^{p-PS}$	pump storage generation/pumping
$p_t^{g-WP}$	wind power generation
$p_{t,i}^{c-EV}, p_{t,i}^{d-EV}$	electric vehicles slow charging/discharging
$p_{t,i}^{f-EV}$	electric vehicles fast charging
$f_{t,i}^{up-TP}, f_{t,i}^{dn-TP}, r_{t,i}^{up-TP}, r_{t,i}^{dn-TP}$	thermal units primary(f)/secondary(r) up/down reserve provision
$f_{t,i}^{up-HP}, f_{t,i}^{dn-HP}, r_{t,i}^{up-HP}, r_{t,i}^{dn-HP}$	hydro units primary(f)/secondary(r) up/down reserve provision
$f_{t,i}^{up-PS}, f_{t,i}^{dn-PS}, r_{t,i}^{up-PS}, r_{t,i}^{dn-PS}$	pump storage primary(f)/secondary(r) up/down reserve provision
$f_{t,i}^{up-EV}, f_{t,i}^{dn-EV}, r_{t,i}^{up-EV}, r_{t,i}^{dn-EV}$	electric vehicles primary(f)/secondary(r) up/down reserve provision
$q_{t,i}^{up-TP}$	thermal units tertiary up reserve provision
$s_{t,i}^{EV}$	total energy in a cluster of EVs
$s_{t,i}^{arr-EV}$	total energy in cluster of EVs arriving to the charging stations
$s_{t,i}^{leav-EV}$	total energy in a cluster of EVs leaving the grid
$p_t^{f-EV}$	percentage of fast charging EVs
$x_{t,i}^{c-EV}$	number of EVs charging
$p_t^{sh-WP}$	curtailed wind power
$C_{t,i}^{TP}$	total thermal power plant cost
$C_{t,i}^{HP}$	total hydro power plant cost

### Input parameters

$P_t^d$	power demand
$F_t^{up}$	primary up reserve requirements
$F_t^{dn}$	primary down reserve requirements
$R_t^{up}$	secondary up reserve requirements
$R_t^{dn}$	secondary down reserve requirements
$Q_t^{up}$	tertiary up reserve requirements
$P_t^{WP}$	potential wind power generation
$R_t^{EV,0.5h}, R_t^{EV,4h}$	secondary and tertiary reserve requirements increase caused by uncontrolled EVs charging
$\sigma_t^{sl(0.5h)-EV}, \sigma_t^{sl(4h)-EV}$	EVs uncontrolled charging standard deviation for secondary and tertiary reserve
$\sigma_t^{(0.5h)-WP}, \sigma_t^{(4h)-WP}$	wind power standard deviation for secondary and tertiary reserve
$N_{\tau,i}^{arr-EV}$	number of EVs arriving (plugging in) to the grid
$N_{t,i}^{g-EV}$	number of EVs connected to the grid
$N_{t,i}^{leav-EV}$	number of EVs leaving the grid
$N_{i,TP}$	number of thermal technology types
$N_{i,HP}$	number of hydro technology types
$N_{i,PS}$	number of pump storage technology types
$N_{i,EV}$	number of electric vehicles types
$\sigma^d$	power demand standard deviation
$p^{gmax}$	the biggest online unit in power system

$C_i^{UCH-EV}$	time needed to fully charge EVs at full power
$\eta_i^{c-EV}$	EV charging efficiency
$\eta_i^{d-EV}$	EVs discharging efficiency
$\Delta t$	time period (0.5 h) for energy calculation
$S_i^{0-EV}$	energy conserved in (all) EVs in time step zero
$S_i^{min-EV}$	the lowest SOC value for one EV
$S_i^{max-EV}$	the highest SOC value for one EV
$S_i^{cons-EV}$	energy conserved in one EV which arrives to the grid
$S_i^{minc-EV}$	the lowest allowed SOC in EVs leaving the grid
$p_i^{fmax-EV}$	fast charging power maximum
$G_i^{EV}$	total number of EVs
$p_i^{max-EV}$	slow charging power maximum

### Abbreviations

BS	battery systems
CCGT	Combined Cycle Gas Turbine
CHPP	Conventional Hydro Power Plant
ColnTh	conventional inflexible thermal system
EPS	electric power system
ES	energy storage
EV	electric vehicle
FITh	flexible thermal system
G2V-NR	grid-to-vehicle without reserve provision capabilities
G2V-YR	grid-to-vehicle with reserve provision capabilities
HP	hydro power
HyTh	Hydro Thermal system
InTh	inflexible thermal system
LCT	low carbon technologies
LoInFl	low carbon inflexible thermal system
MILP	Mixed Integer Linear Programming
NO-EV	Mode without EVs
NPP	nuclear power plants
OCGT	Open Cycle Gas Turbine
PS	pump storage
RES	renewable energy sources
RoR	run-of-river
SO	system operator
SOC	state-of-charge
TP	thermal power
TSC	Total System Cost
TSE	Total System Emissions
UC	unit commitment
UCH-NR	uncontrolled charging without additional reserve requirements
UCH-YR	uncontrolled charging with additional reserve requirements
V2G-NR	vehicle-to-grid without reserve provision capabilities
V2G-YR	vehicle-to-grid with reserve provision capabilities
WPP	Wind Power Production

flexibility provider as can be found in [4–7]. Microgrids are another promising concept where, by aggregating groups of geographically close loads and generators, the focus is shifting from centralized service provision to local, more system independent as described in [8,9]. However, currently the only integrated concept is that of demand response programs which includes changes in electric consumption by end-users in response to changes in electricity

prices throughout day [10,11]. This concept has the potential to increase the systems flexibility by providing reserve to power systems in exchange for lower cost electricity for the end-users.

The focus of this paper is highlight the benefits of controlled electric vehicles charging which can be considered as a combination of all those aforementioned concepts; the battery on board acts as a storage unit, while a parallel can be drawn between

behaviour of drivers and household consumers and their geographical disparity which resembles that of multi microgrid components. Electric vehicles (EVs) are in fact additional demand to electric power system, however depending on their charging behaviour they can be seen as uncontrolled (inflexible) or controlled (flexible) load. Controlled charging of EVs means that EVs are demand responsive loads whose interaction with electric power system (charging) is driven by market or system operator signals throughout day. Since EVs can store energy they can also be observed as mobile energy storage units that can charge or discharge energy. Although EVs could be charged at home or work (slow charging) or at charging stations (fast charging), this paper observes only slow-charging EVs. Integration of new electricity consumers is often followed by additional investments into transmission and distribution network infrastructure, since investments follow human activity. This in terms means most of potential network upgrades would be at residential level. However, if EV charging is managed wisely investing in electric networks could be deferred. When all mentioned is recapitulated, EVs seem to have significant potential for providing flexibility both in energy and ancillary services.<sup>1</sup>

This paper will provide a critical estimation of EVs benefits to the high share RES power systems through a detailed analyses of participation in both energy and reserve services analysing different energy mixes and EV charging strategies.

## 2. Main contributions and literature overview

One of the most energy-consuming sectors, with more than 25% contribution in total energy consumed worldwide, is transportation sector [12], similar to the share of greenhouse gases coming from it. Regulatory trends drive the transformation of transportation sector from oil-consuming to electricity-consuming sector. Large number of EVs is already on the roads and more of them is predicted to be released into the market in the next few years [13–15].

A number of papers focuses on the capability of EVs to participate in the ancillary service markets. However, there is still a lack of research defining what are the benefits of coordinated EVs charging with respect to different energy mix and overall system cost or elaboration how does the participation of EVs alter the role of traditional plants in providing different services. Paper [16] proposes aggregated EVs command architecture where EVs communicate with their aggregator who then acts as a single market entity and posts bids on energy and ancillary services market. The availability, reliability and value of EVs provided ancillary services is calculated both for single EV direct participation and aggregated architecture and compared with that of gas turbines. Aggregative architecture has higher or same availability and reliability as that of gas turbines but, as one would expect, lower revenues for ancillary services compared with direct EV participation. There is significant potential for financial return for the EV's owners when V2G is used for regulation provision and even higher when combined with peak reduction (EVs power injections during peak hours) as found in [17]. Authors in [18] have revealed that profitable peak reduction could be achievable through real-time scheduling techniques. Brief description of control reserves, similar to those used in this paper, and V2G revenues for ancillary services provision with different levels of charging infrastructure is provided in [19]. Costs and revenues for ancillary services provision for different EV's fleets and different regulation markets are presented in [20]. Authors used four regulation markets (NYISO, CAISO, ERCOT and PJM) for annual profit calculation which is on some level

similar to different energy mixes analyses in this paper. Different markets entails different internal generation structure, e.g. energy mixes. The difference is that this paper observes savings for system operator whereas authors of aforementioned research analyse profits for EV owners. Papers [21–23] present primary frequency control of EVs on smaller timescale, few hours, with higher power fluctuations resolution (minutes). Primary reserve in this paper is analysed as pre-occupied space which could be otherwise used for power generation. EVs as responsive demand (in this case it means to unplug EVs if frequency drops) for frequency support through different charging strategies with different charging profiles are observed in [24]. Detailed unit commitment (UC) model is presented in [25] where EVs are analysed through five modes: EVs charging, EVs discharging, EVs for reserve provision only, EVs used for transport and idle plugged-in EVs. The studies in the paper focus on peak increase in case where EVs are uncontrollably charged, charging and discharging behaviour over day for different mark-ups for power injections, state-of-charge (SOC) of EVs over day, reserve provision by EVs over day for different price of reserve, etc. However, all the analyses are again conducted only for a single day and from the aspect of the EV owner as market participant. Stochastic EVs model is formulated in [26] where objective function incorporates multiple markets (day-ahead energy, stochastic intraday energy, regulating reserve) and costs (reserve compensation and driver satisfaction cost). The last mentioned cost represents penalties for non-supplied energy to EVs which results in a conclusion that committing EVs for reserve introduces profit reduction for EV. However, it does not provide insight into scheduling of energy and reserve services and does not answer a question of how these services shift to new units with the introduction of EV. In addition, it does not provide annual analyses to properly evaluate the benefits of EV integration. In [27], a UC model of thermal generation based power system with incorporated EVs is presented. Authors modelled EVs as additional cost and included revenues for ancillary service provision. Traditional units act differently when EVs are used for ancillary services. EVs reserve provision increases efficiency of online units and turn-off the most expensive one. Although similarities with this paper's analyse exist, mentioned paper provides shallower analyse of thermal units reserve provision, unit commitment, system decreased cost etc. Another detail model of V2G assets is defined in [28]. Different EV's battery replacement costs and different types of EVs are used in these simulations. Higher battery replacement cost entails smaller amount of energy injected back to grid and smaller amount of regulation up capacity sold to the system operator (SO). Positive interaction between high wind power production and EV's contingency reserve provision are explained the case of Irish power system (52% of wind penetration) in [29]. Interesting work is presented in [30] where EVs charging is explored as an alternative for additional cross-border transmission investments. Besides transmission investment deferral, the paper found that RES curtailment, electricity price and energy storage usage are reduced when EVs charging is controlled. Covering EVs charging by means of variable renewable generation is done in [31]. Authors compare coordinated and uncoordinated charging in a week and annual simulations with sensitivity analyses on charging power, generation portfolio and charging availability. The last two papers observe only EVs charging, while EVs discharging and reserve provision has not been discussed. Worth mentioning study, focusing on energy provision by EV, is [32]. Authors are observing EVs as distributed energy storage system on a single day time scale but they do not consider EVs as potential reserve providers. Detail research on EVs emissions performance on different driving patterns, charging profiles and electricity mix is done in [33]. Along with the presented literature a short review of the EVs participation in frequency regulation is given in [34].

<sup>1</sup> Term of ancillary services in this paper is used for multiple reserve services, with focus on provision of spinning reserve services (in particular secondary reserve).

Most of the above mentioned papers observe revenues for potential EV owners analysing participation in ancillary service markets as potentially interesting business model for the end EVs users or aggregators. The goal of the paper is to define the impact of EV integration from the standpoint of the power system operator. Benefits from EV aggregation is not the topic of this paper; in other words the system does not care whether EVs cooperate under the aggregator principle or they work alone, as long as they provide the required service. Results of this paper are primarily recognizing benefits and improvements for power system operation in terms of operational cost, environmental benefits and reduced wind curtailment. The important questions that will be answered throughout paper are: how do EVs affect traditional unit commitment for energy and reserve services? How does provision of reserve from EV's affect traditional unit commitment for power and reserve? When will the system gain most from the EV's? How does the increase in EV's percentage affect the profitability of EV's reserve provision? How do EVs affect wind curtailment in future high share wind systems? Is there a positive correlation between increase in WPP and increase in EV's percentage? Which energy mixes acquire most benefits from EV's reserve provision?

Compared to the existing literature, the paper brings novelty through detailed analysis of provision of spinning reserve services and elaboration how service provision shifts from traditional units to more flexible and environmentally friendlier units. It also recognizes that flexibility benefits are different for different energy mixes through annual analyses of all three relevant flexibility metrics: operational cost, CO<sub>2</sub> emissions and wind curtailment.

The following Section, Section 3, elaborates the unit commitment model based on mixed integer linear programming (MILP) and input parameters used, focusing on thorough explanation of EVs behaviour equations. First part of Section 4 provides an answers on the above stated questions by analysing one-week simulation results. In second part of Section 4 annual analyses defines benefits of EV coordinated participation in multiple markets for various energy mix power systems. Section 5 provides concluding remarks, emphasizing the most important contributions of the paper.

### 3. Power system components and modelling

All simulations are run in Fico Xpress programming environment [35] on a Lenovo ThinkCentre computer (4 GB RAM). The electric power system is composed of conventional power plants such as hydro, fossil based thermal power plants and nuclear power plants with the capability of changing the energy mix and, by doing that, representing specific country system. This system is upgraded with models of emerging new technologies such as EVs, wind power plants (WP), and stationary battery systems (BS). Simulation model's architecture is designed to correspond to different national power systems; depending on the input data it can provide results for whatever power system's architecture. To speed up the simulations the system components are clustered by type of particular technology, since number of relevant papers have demonstrated accuracy of such approach, see [36,37]. The following subsections explain in detail vital components of proposed model and their input parameters. Graphical representation of proposed EPS and used scenarios are shown later in the paper, Section 3.3 in Fig. 3. For better understanding of the mathematical expressions it is important to keep in mind:

- Decision variables are written in italic lower case.
- Input parameters are written in roman upper case (or roman Greek letters).
- Extended variable/parameter name is written as roman superscript before underline.

- Technology to which variable/parameter is referring to is written as roman superscript after the underline.
- Indexes are written as italic subscript.
- Index  $i$  corresponds to type of particular technology.
- Index  $t$  corresponds to particular time step.
- All equations are written for one particular time-step/technology but they all apply to all time-steps/technologies in observed range (with the exception of initial conditions).
- Time step in this paper is 0.5 h which entails 336 time steps for one week period.
- Unless otherwise noted decision variables are nonnegative values.

#### 3.1. Power system and electrical demand

Electric generation and consumption equilibrium must be satisfied in all time-steps. Mathematical notation of the last sentence is contained in (1). Left side of the equation present conventional (thermal –  $p_{t,i}^{g\_TP}$ , hydro –  $p_{t,i}^{g\_HP}$ , pump storage –  $p_{t,i}^{g\_PS}$ ) and RESs (wind –  $p_{t,i}^{g\_WPP}$ ) generation and pump storage pumping ( $p_{t,i}^{p\_PS}$ ) with added EVs discharging ( $p_{t,i}^{d\_EV}$ ), charging ( $p_{t,i}^{c\_EV}$ ) and fast charging ( $p_{t,i}^{f\_EV}$ ), while left side present electric demand ( $P^d$ ). Electric demand for UK power system, which is a typical low flexible power system relying on thermal power plants, is displayed in Fig. 1 for typical high (60 GW – winter peak) and low-demand week (50 GW) [38]. Additional data about UK power system used can be found in [39].

$$\sum_{i=1}^{Ni\_TP} (p_{t,i}^{g\_TP}) + \sum_{i=1}^{Ni\_HP} (p_{t,i}^{g\_HP}) + \sum_{i=1}^{Ni\_PS} (p_{t,i}^{g\_PS} - p_{t,i}^{p\_PS}) + p_t^{g\_WP} - \sum_{i=1}^{Ni\_EV} (p_{t,i}^{d\_EV} - p_{t,i}^{c\_EV} - p_{t,i}^{f\_EV}) = P_t^d \quad (1)$$

Other system related Eqs. (2)–(6) are reserve provision requirements. As it can be seen from the following equations, five reserve services are modelled:

- Primary reserve up ( $f^{up}$ ).
- Primary reserve down ( $f^{dn}$ ).
- Secondary reserve up ( $r^{up}$ ).
- Secondary reserve down ( $r^{dn}$ ).
- Tertiary up ( $q^{up}$ ).

$$\sum_{i=1}^{Ni\_TP} f_{t,i}^{up\_TP} + \sum_{i=1}^{Ni\_HP} f_{t,i}^{up\_HP} + \sum_{i=1}^{Ni\_PS} f_{t,i}^{up\_PS} + \sum_{i=1}^{Ni\_EV} f_{t,i}^{up\_EV} \geq F_t^{up} \quad (2)$$

$$\sum_{i=1}^{Ni\_TP} f_{t,i}^{dn\_TP} + \sum_{i=1}^{Ni\_HP} f_{t,i}^{dn\_HP} + \sum_{i=1}^{Ni\_PS} f_{t,i}^{dn\_PS} + \sum_{i=1}^{Ni\_EV} f_{t,i}^{dn\_EV} \geq F_t^{dn} \quad (3)$$

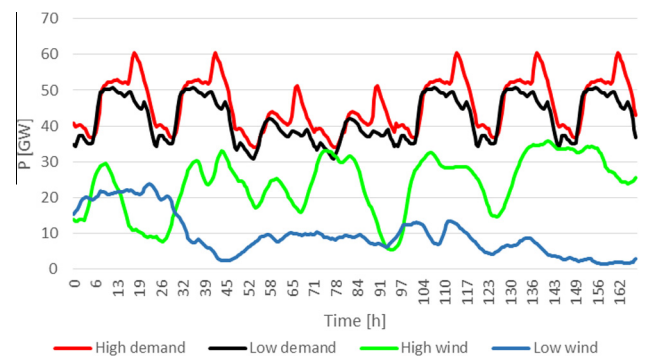

Fig. 1. Weekly demand and wind profiles.



$$\sum_{i=1}^{Ni\_TP} r_{t,i}^{up\_TP} + \sum_{i=1}^{Ni\_HP} r_{t,i}^{up\_HP} + \sum_{i=1}^{Ni\_PS} r_{t,i}^{up\_PS} + \sum_{i=1}^{Ni\_EV} r_{t,i}^{up\_EV} \geq R_t^{up} \quad (4)$$

$$\sum_{i=1}^{Ni\_TP} r_{t,i}^{dn\_TP} + \sum_{i=1}^{Ni\_HP} r_{t,i}^{dn\_HP} + \sum_{i=1}^{Ni\_PS} r_{t,i}^{dn\_PS} + \sum_{i=1}^{Ni\_EV} r_{t,i}^{dn\_EV} \geq R_t^{dn} \quad (5)$$

$$\sum_{i=1}^{Ni\_TP} q_{t,i}^{up\_TP} \geq Q_t^{up} \quad (6)$$

Detailed description of mentioned control reserves could be found in [40]. Primary and secondary reserve in this work are provided by online units (thermal, hydro, EVs), whereas tertiary control can be provided from both online and offline quick-start (CCGT, OCGT) units. Primary control reserve, both up and down, are at constant values of 1.9 GW as they corresponds to the reserve for frequency response in UK power system [38]. Secondary and tertiary control are time vectors of constant values. They depend on the electrical demand (taking into account variability of demand through standard deviations of load forecast  $\sigma^d$ ), wind power production (taking into account uncertainty and variability of wind generation by standard deviation of wind forecast on different time scales through variables  $\sigma^{(0.5h)\_WP}$  and  $\sigma^{(4h)\_WP}$ ) and EV's charging mode (by taking into account a fixed value describing uncertain nature of EV arrival and battery SOC through variables  $R^{EV\_0.5h}$  and  $R^{EV\_4h}$ ), as well as the outage of the largest generating unit  $P^{gmax}$  [41]. Uncontrolled charging (UCH) mode, due to its uncontrollability, cannot participate in energy markets (in terms of shifting its charging to a more favourable periods) nor provide ancillary services to the system operator. In addition, due to its unpredictability and variability UCH can increase system's reserve requirements. An estimation of UCH mode reserve increase (7) is added to standard reserve requirements formulas (8)–(10). Up reserve requirements include the largest online unit (this is taken into account as the largest generator outage). Reserves are modelled as in [37,42].<sup>2</sup>

$$R_t^{EV\_0.5h} = \sum_{i=1}^{Ni\_EV} \left( 3.5 * \sigma_t^{sl(0.5h)\_EV} * P_i^{max\_EV} * \sum_{\tau=t}^{(t-c_i^{UCH\_EV}+1)} N_{\tau,i}^{arr\_EV} \right) \quad (7)$$

$$R_t^{up} = \sqrt{\left( 3 * \sigma^d * P_t^d \right)^2 + \left( 3.5 * \sigma_t^{(0.5h)\_WP} * P_t^{WP} \right)^2 + \left( R_t^{EV\_0.5h} \right)^2} + P^{gmax} \quad (8)$$

$$R_t^{dn} = \sqrt{\left( 3 * \sigma^d * P_t^d \right)^2 + \left( 3.5 * \sigma_t^{(0.5h)\_WP} * P_t^{WP} \right)^2 + \left( R_t^{EV\_0.5h} \right)^2} \quad (9)$$

$$Q_t^{up} = \sqrt{\left( 3 * \sigma^d * P_t^d \right)^2 + \left( 3.5 * \sigma_t^{(4h)\_WP} * P_t^{WP} \right)^2 + \left( R_t^{EV\_4h} \right)^2} + P^{gmax} \quad (10)$$

### 3.2. Conventional power plants

As already mentioned, the core of the analysed EPS's are hydro-thermal generating units. All units are modelled as clustered and participate in daily schedule together. Additional explanation of the conventional and clustered UC thermal model with or

without RES could be found in [37,42,43]. Also, interesting recent publications related to the UC issues can be found in [44–46]. Thermal units are subjected to the following constraints:

- Power generation constraints (piece-wise linear cost curve).
- Minimum up and down times.
- Ramping constraints.
- Reserve provision constraints (primary, secondary and tertiary).
- Greenhouse gas emissions (included as additional cost in objective function).

Four different types of thermal power plants (TP) are considered:

- Nuclear power plants.
- Coal-fired thermal power plants.
- Combined-Cycle Gas Turbines (CCGT).
- Open-Cycle Gas Turbines (OCGT).

Hydro Power Plants (HP) are modelled with small adjustments relative to the models in the available literature [1,47]. Hydro units are subjected to the following constraints<sup>3</sup>:

- Water balance equation.
- Power generation constraints.
- Reservoir constraints.
- Hydro turbine constraints.
- Spillage constraint.
- Reserve provision constraints (primary, secondary and tertiary);

Three different types of hydro power plants (HP) are considered:

- Run-of-river hydro power plants (RoR).
- Conventional Hydro Power Plants with daily accumulation (CHPP).
- Pump storage (PS).

Thermal and hydro power plants parameters can be found in Appendix (Tables 3 and 4).

### 3.3. Electric vehicles

As stated above, RES introduced new challenges to traditional EPS's operation principles. The incapability to accurately forecast their next day schedule resulted in new operating costs to the EPSs. Flexible and responsive units have to be scheduled in order to provide stable operation and unavailability of such units leads to wind curtailment, lower generation efficiency of conventional units, and transmission congestions. Smart planning of EV's charging infrastructure and EV's batteries has the potential to alleviate some of the challenges and to provide the needed flexibility enabling further integration of variable and uncertain RES. Depending on their operation mode EVs could behave as new source of flexibility or they could further damage system's flexibility. For the purpose of this work EV's are modelled through six operation models as follows:

- Uncontrolled Charging with No additional Reserve requirements (UCH-NR) – EVs plug-in when they stop driving and charge until fully charged and their charging does not affect reserve requirements.

<sup>2</sup> The same formula applies for  $R_t^{EV\_4h}$  in (10), the only difference is substitution of  $\sigma^{sl(0.5h)\_EV}$  with  $\sigma^{sl(0.5h)\_EV}$ .

<sup>3</sup> Pump storage units are subjected to "double" constraints (upper and lower reservoir, generation and pumping, etc.).

- Uncontrolled CHarging with (Yes) impact on Reserve (UCH-YR) – EVs plug-in when they stop driving and charge until fully charged. The uncertainty of their arrival time and SoC of batteries increases reserve requirements. These first two types focus on an issue still not properly addressed in the literature – EV as additional source of uncertainty and variability.
- Controlled grid-to-vehicle charging with No possibility for providing Reserve (G2V-NR) – optimal allocation of EVs charging resources without possibility to inject power back to grid or to provide reserve services.
- Controlled grid-to-vehicle charging with (Yes) possibility to provide Reserve (G2V-YR) – optimal allocation of EVs charging resources without possibility to inject power back to grid but with possibility to provide primary and secondary reserve.
- Controlled vehicle-to-grid charging with No possibility for providing Reserve (V2G-NR) – optimal allocation of EVs charging resources with possibility to inject power back to grid but without participating in different reserve services provision.
- Controlled vehicle-to-grid charging with (Yes) possibility to provide Reserve (V2G-YR) – optimal allocation of EVs charging resources with possibility to inject power back to grid and with the possibility to provide reserve services.

All of these operating modes are subjected to the following constraints:

$$S_{t,i}^{EV} = S_{t-1,i}^{EV} + S_{t,i}^{arr\_EV} - S_{t,i}^{leav\_EV} + p_{t,i}^{c\_EV} * \eta_i^{c\_EV} * \Delta t + p_{t-1,i}^{f\_EV} * \eta_i^{c\_EV} * \Delta t - p_{t,i}^{d\_EV} / \eta_i^{d\_EV} * \Delta t \quad (11)$$

$$S_{1,i}^{EV} = S_i^0 + S_{1,i}^{arr\_EV} - S_{1,i}^{leav\_EV} + p_{1,i}^{c\_EV} * \eta_i^{c\_EV} * \Delta t + p_{Nt,i}^{f\_EV} * \eta_i^{c\_EV} * \Delta t - p_{1,i}^{d\_EV} / \eta_i^{d\_EV} * \Delta t \quad (12)$$

$$S_{Nt,i}^{EV} \geq S_i^0 \quad (13)$$

$$N_{t,i}^{g\_EV} * S_i^{min\_EV} + S_{t,i}^{arr\_EV} - S_{t,i}^{leav\_EV} \leq S_{t,i}^{EV} \leq N_{t,i}^{g\_EV} * S_i^{max\_EV} + S_{t,i}^{arr\_EV} - S_{t,i}^{leav\_EV} \quad (14)$$

$$0 \leq S_{t,i}^{arr\_EV} \leq N_{t,i}^{arr\_EV} * S_i^{cons\_EV} \quad (15)$$

$$N_{t,i}^{leav\_EV} * S_i^{minc\_EV} \leq S_{t,i}^{leav\_EV} \leq N_{t,i}^{leav\_EV} * S_i^{max\_EV} \quad (16)$$

$$p_{t,i}^{f\_EV} \geq p_t^{f\_EV} / 100 * P_i^{fmax\_EV} * (G_i^{EV} - N_{t,i}^{g\_EV}) / 3 \quad (17)$$

EVs are aggregated and observed as one unit with time-dependant parameters. Energy conservation equation of aggregated EVs is represented in (11). Energy stored in all EVs of type  $i$  (the model observes three types of EV, as explained later) at time step  $t$  is on the left side of equality sign ( $S_t^{EV}$ ), whereas right side is composed of energy stored at past time step  $\pm$  energy stored in arriving/leaving ( $S_{t,i}^{arr\_EV}/S_{t,i}^{leav\_EV}$ ) EVs,  $\pm$  charged (slow  $p_{t,i}^{c\_EV}$  and fast  $p_{t-1,i}^{f\_EV}$ ) and discharged ( $p_{t,i}^{d\_EV}$ ) EVs energy at actual time step. Initial and final conditions are shown as (12) and (13). Eq. (14) represent boundaries for EVs storage size. EVs usually do not discharge their entire stored energy for driving, meaning that most of the energy is still stored when they plug-into the charging point. Three types of EVs are developed based on their trip lengths (based on their consumed energy for driving) as shown in Table 1. Percentage of EV's types in EV's fleet is chosen to match real proportions (Table 1) based on the [48]. One week driving patterns are extracted from the same study [48]. Every day is modelled with representative driving patterns as shown on Fig. 2. Input vectors  $N_{t,i}^{g\_EV}$ ,  $N_{t,i}^{arr\_EV}$  and  $N_{t,i}^{leav\_EV}$  are derived from those curves. Variable  $S_{t,i}^{arr\_EV}$  denotes unconsumed energy of returning EVs (15). Variable  $S_{t,i}^{leav\_EV}$  denotes

**Table 1**  
Electric vehicle's parameters.

Input parameter	Personal vehicle	
$P_{min}$ (kW)	0.2	
$P_{max}$ (kW)	2	
$S_{min}$ (kW h)	4	
$S_{max}$ (kW h)	20	
$S_{minc}$ (kW h)	20	
$\eta_c, \eta_d$	0.95	
$P_{fmax}$ (kW)	50	
Range (km)	Short	20
	Medium	40
	Long	80
Consumed energy per trip (kW h)	Short	4
	Medium	8
	Long	16
Percentage of EVs type and range in total number of EVs	Short	82%
	Medium	10%
	Long	8%

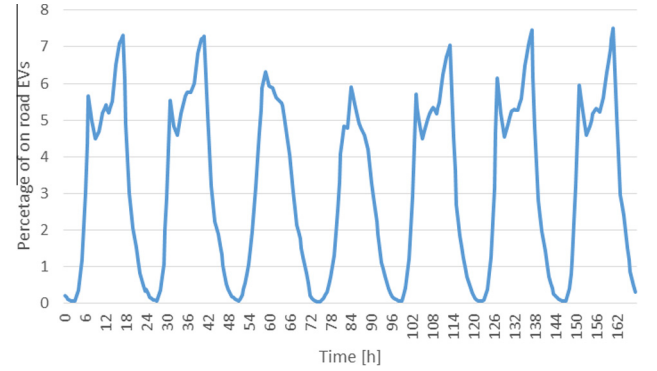

**Fig. 2.** EVs driving pattern.

energy stored in EVs leaving the grid (16). It is assumed that all EV's owners require 100% SOC when leaving the grid ( $S_i^{minc\_EV} = S_i^{max\_EV}$ ). Although the number of vehicles can be modelled as variable (17), fast charging in this paper is taken as constant value; 5% of on-road EVs are allowed to use fast-charging stations ( $p_t^{f\_EV} = 5\%$ ). The assumed duration of fast charging is ten minutes and to assure this, right side of (17) is divided by 3 ((30 min time period/3) = 10 min charging). Fast charging is assumed to be uncontrolled so it increases reserve requirements in a similar manner as uncontrolled slow charging as shown in Eqs. (8)–(10). This paper analyses only slow charging effect on the EPS so no additional description of fast charging model will be provided.

Specific constraints for different charging modes are listed below (18)–(26).

UCH:

$$p_{t,i}^{d\_EV} = 0 \quad (18)$$

$$C_i^{UCH\_EV} = \text{round} \left\{ \frac{S_i^{max\_EV} - S_i^{cons\_EV}}{P_i^{max\_EV} * \Delta t} \right\} \quad (19)$$

$$\begin{aligned} & \sum_{(\tau=Nt+t-C^{UCH\_EV}+1)}^{Nt} (N_{\tau,i}^{arr\_EV} * P_i^{max\_EV} * 0.9) \\ & + \sum_{\tau=1}^t (N_{\tau,i}^{arr\_EV} * P_i^{max\_EV} * 0.9) \leq p_{t,i}^{c\_EV} \\ & \leq \sum_{(\tau=Nt+t-C^{UCH\_EV}+1)}^{Nt} (N_{\tau,i}^{arr\_EV} * P_i^{max\_EV} * 1.1) \\ & + \sum_{\tau=1}^t (N_{\tau,i}^{arr\_EV} * P_i^{max\_EV} * 1.1) \end{aligned} \quad (20)$$

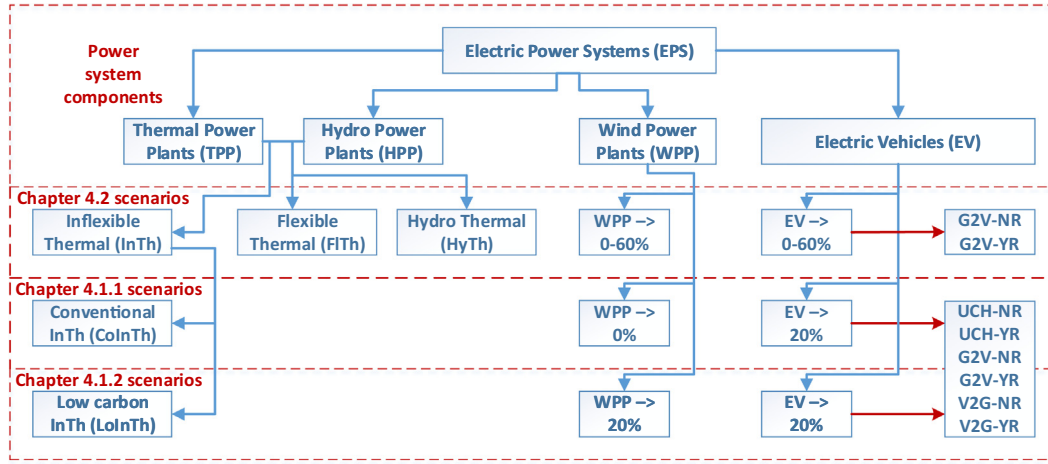

Fig. 3. Modelled power system and scenarios used in simulations.

$$\sum_{(\tau=t-C_{\text{UCH\_EV}}+1)}^t \left( N_{\tau,i}^{\text{arr\_EV}} * P_i^{\text{max\_EV}} * 0.9 \right) \leq p_{t,i}^{\text{c\_EV}}$$

$$\leq \sum_{(\tau=t-C_{\text{UCH\_EV}}+1)}^t \left( N_{\tau,i}^{\text{arr\_EV}} * P_i^{\text{max\_EV}} * 1.1 \right) \quad (21)$$

G2V:

$$p_{t,i}^{\text{d\_EV}} = 0 \quad (22)$$

$$0 \leq p_{t,i}^{\text{c\_EV}} \leq P_i^{\text{max\_EV}} * N_{t,i}^{\text{g\_EV}} \quad (23)$$

V2G:

$$0 \leq x_{t,i}^{\text{c\_EV}} \leq N_{t,i}^{\text{g\_EV}} \quad (24)$$

$$0 \leq p_{t,i}^{\text{c\_EV}} \leq P_i^{\text{max\_EV}} * x_{t,i}^{\text{c\_EV}} \quad (25)$$

$$0 \leq p_{t,i}^{\text{d\_EV}} \leq P_i^{\text{max\_EV}} * \left( N_{t,i}^{\text{g\_EV}} - x_{t,i}^{\text{c\_EV}} \right) \quad (26)$$

Uncontrolled charging mode does not allow EVs to inject power back into the distribution grid (18). Auxiliary constant  $C_i^{\text{UCH\_EV}}$  represents time necessary to fully charge EV's battery while charging is at rated power. Initial conditions are modelled in (20). EV's driving patterns are constructed continuously from available weekly data, meaning that  $N_{t,i}^{\text{arr\_EV}}$  data from time steps before time step 1 are the same as that of the last time steps. In other words required  $N_{t,i}^{\text{arr\_EV}}$  for periods before first time step are not exclusively modelled but taken from last periods. Charging in remaining periods is modelled with (21).

The concept of UCH is inflexible, meaning once EVs are plugged-in they are being charged at power ranging from 90% to 110% of battery's rated power till they fully charged. Controlled G2V charging mode allows only charging during periods beneficial for the system as shown in (22) and (23). On the other hand in the controlled V2G regime, discharging energy into the grid is additionally allowed as modelled in (25) and (26). Integer variable  $x_{t,i}^{\text{c\_EV}}$  denotes the number of EVs being charged at time  $t$  (24), whereas  $(1 - x_{t,i}^{\text{c\_EV}})$  denotes the number of EVs being discharged at time  $t$ .

All of the charging modes (UCH, G2V and V2G) may have an impact on reserve requirements. Due to its uncontrollability, variability and uncertainty, UCH will most likely negatively affect the reserve requirements, resulting in increase in system reserve requirements, as shown in (8)–(10). G2V and V2G due to their controllability can be observed in the context of additional reserve

provision to the EPS. In all three modes, EV's influence on reserve is included or excluded from consideration based on author's decision, resulting in multiple scenarios for different service provision. The secondary reserve provision in the G2V charging mode is modelled with (27) and (28), and in the V2G mode in (31) and (32). Same applies for primary reserve plus additional decrease for already allocated secondary reserve ( $r_{t,i}^{\text{up\_EV}}/r_{t,i}^{\text{dn\_EV}}$ ) as can be seen in (29), (30), (33) and (34).

G2V:

$$r_{t,i}^{\text{up\_EV}} \leq p_{t,i}^{\text{c\_EV}} \quad (27)$$

$$r_{t,i}^{\text{dn\_EV}} \leq P_i^{\text{max\_EV}} * N_{t,i}^{\text{g\_EV}} - p_{t,i}^{\text{c\_EV}} \quad (28)$$

$$f_{t,i}^{\text{up\_EV}} \leq p_{t,i}^{\text{c\_EV}} - r_{t,i}^{\text{up\_EV}} \quad (29)$$

$$f_{t,i}^{\text{dn\_EV}} \leq P_i^{\text{max\_EV}} * N_{t,i}^{\text{g\_EV}} - p_{t,i}^{\text{c\_EV}} - r_{t,i}^{\text{dn\_EV}} \quad (30)$$

V2G:

$$r_{t,i}^{\text{up\_EV}} \leq P_i^{\text{max\_EV}} * \left( N_{t,i}^{\text{g\_EV}} - x_{t,i}^{\text{c\_EV}} \right) - p_{t,i}^{\text{d\_EV}} + p_{t,i}^{\text{c\_EV}} - P_i^{\text{min\_EV}} * x_{t,i}^{\text{c\_EV}} \quad (31)$$

$$r_{t,i}^{\text{dn\_EV}} \leq p_{t,i}^{\text{d\_EV}} - P_i^{\text{min\_EV}} * \left( N_{t,i}^{\text{g\_EV}} - x_{t,i}^{\text{c\_EV}} \right) + P_i^{\text{max\_EV}} * x_{t,i}^{\text{c\_EV}} - p_{t,i}^{\text{c\_EV}} \quad (32)$$

$$f_{t,i}^{\text{up\_EV}} \leq P_i^{\text{max\_EV}} * \left( N_{t,i}^{\text{g\_EV}} - x_{t,i}^{\text{c\_EV}} \right) - p_{t,i}^{\text{d\_EV}} + p_{t,i}^{\text{c\_EV}} - P_i^{\text{min\_EV}} * x_{t,i}^{\text{c\_EV}} - r_{t,i}^{\text{up\_EV}} \quad (33)$$

$$f_{t,i}^{\text{dn\_EV}} \leq p_{t,i}^{\text{d\_EV}} - P_i^{\text{min\_EV}} * \left( N_{t,i}^{\text{g\_EV}} - x_{t,i}^{\text{c\_EV}} \right) + P_i^{\text{max\_EV}} * x_{t,i}^{\text{c\_EV}} - p_{t,i}^{\text{c\_EV}} - r_{t,i}^{\text{dn\_EV}} \quad (34)$$

### 3.4. Renewable energy sources

Real historical data ( $P_r^{\text{WP}}$ ) from Fig. 1 are used to model actual wind power production ( $p_t^{\text{g\_WP}}$ ) and it is displayed in Fig. 1. Decision variable  $p_t^{\text{sh\_WP}}$  allows wind curtailment (shedding). Wind curtailment is undesirable and it is a metric to evaluate the EPS's flexibility; the larger the curtailment the less flexible the EPS is. Wind Power Production (WPP) is represented with (35).

$$p_t^{\text{g\_WP}} + p_t^{\text{sh\_WP}} = P_t^{\text{WP}} \quad (35)$$

### 3.5. Objective function

The objective function is minimization operational costs from the units providing energy and reserve services to the system (36). Thermal (start-up, shut-down, fuel, O&M, greenhouse gas emissions) and hydro (O&M) costs are included. Thermal fuel consumption curve is piece-wise linearized (3 segments) [37,42].

$$\min \text{ COST} = \sum_{t=1}^{N_t} \left[ \sum_{i=1}^{N_{i-TP}} (c_{t,i}^{TP}) + \sum_{i=1}^{N_{i-HP}} (c_{t,i}^{HP}) \right] \quad (36)$$

## 4. Simulation and results

Weekly and annual simulations are performed in this section to gain insight into EV impact on UC performance and traditional principles of providing market services. First part of simulations aim to show EV's physical and economic impact on power and reserve one-week unit commitment. This is shown in Figs. 4 and 7 through three different graphs presenting: (i) EVs charging/discharging and their impact on conventional energy scheduling; (ii) secondary up and (iii) secondary down reserve. Although the designed model enables multi reserve service analyses, as already mentioned, due to space constraints only secondary reserve scheduling will be shown. The results are shown for the base case (without EVs or NO-EV case) and compared with other above listed EV's operating modes. In addition, two different scenarios are taken into account: Conventional Inflexible Thermal (CoInTh) system, with no wind penetration, and low carbon inflexible thermal system with 20% of RESs (LoInFl).

Second part of simulations focuses on EVs and WPPs interaction for G2V charging mode with and without EV's reserve provision capabilities. EPS's savings and wind curtailment decrease caused by EV's reserve provision are the main indicators of EV's capability to enhance flexibility of high RES systems. Seven different percentages of EVs and WPPs, ranging from 0% to 60% with 10% step increase, and three different energy mix scenarios are used: Inflexible Thermal (InTh), Flexible Thermal (FlTh) and Hydro-Thermal (HyTh) system. Details on these scenarios are provided in later subsections. Integration of particular technologies used in different scenarios is presented in Table 2. EV's input parameters are shown in Table 1.

### 4.1. One-week simulations

#### 4.1.1. Conventional inflexible thermal system (CoInFl)

Fig. 4 displays EV's charging and discharging behaviour as well as secondary up and down reserve provision (these are represented by three graphs in each row shown on x-axis) for simulations of the CoInTh system. The analyses are done for base case without EVs (NO-EV) and are compared with 6 other scenarios changing charging/discharging modes of EV as well as type of services they can provide (this are in order shown on y-axis in Fig. 4). For easier understanding of the results in Fig. 4 the following should be kept in mind:

- First vertical column graphs present scheduling of energy in UC for total of 7 scenarios; the first one without EV and six for different charging strategies of EV.
- Second and third vertical column present secondary up and down reserve for total of 7 scenarios; the first one without EV and six for different charging strategies of EV.

Although the presented UC model considers scheduling of multiple services, due to limited space, Fig. 4 shows the results only for secondary reserve service. It should be mentioned that the same

comparison and analyses could be done for primary and tertiary reserve as well.

The analysed EPS resembles that of the UK and for relevant analysis and comparison all the other data is taken for the UK system as well. There are approximately 30 million cars in UK at the moment [49]. For the purposes of this simulation the assumption is made that 10% of those vehicles is going to be replaced with EVs. If all those EVs would charge at the same moment it would increase the electricity demand by 20%, i.e. by 12 GW. Further in the paper number of EVs will be expressed as percentage of total electric demand not as percentage of total number of vehicles on road.

Base case (NO-EV) represents conventional unit commitment model with no RESs and EVs. Nuclear units cover base load, they do not alter their production and do not provide any kind of reserve. Although NPP are not inflexible units, traditional approaches suggest NPP are not used for provision of ancillary services, with the exception of contingency reserves, nor for following net demand changes. Coal power plants are units of limited flexibility and they provide both the up and down reserve. CCGT units cover workday's daily peak period demand, and are almost completely shut down on weekends due to lower electricity demand. The only period when CCGT units provide up reserve are those days of the week when they also cover part of the energy demand. This is happening only during peak periods since lower cost coal power plants are running at their maximum and additional required reserve is provided by more expensive online units such as CCGT. Although some CCGT units are scheduled to provide down reserve during peak periods, almost all down reserve is provided by coal. Aforementioned occurs since coal units are used to provide most of the energy (taking into account only units that can provide reserve, so excluding NPP) and thus, a logical way to provide down reserve is to ramp coal units down. OCGT units are the most expensive units and also the most flexible units, however they are offline most of the time. With the exception of some specific periods, they are primarily used to provide the required tertiary reserve.

The second analysis shows how EPS operation changes with the integration of non-flexible EVs. Charging of uncontrollable EV is presented by green line in first graph (energy graph, second row and first column of Fig. 4) of the unit commitment. The demand curve of EVs charging requirements follows their driving patterns (Fig. 2). Required power for EV charging is high throughout day, with peak charging power in the afternoon when most of the EVs return home. Blue line in the energy graph displays demand without EV, so comparing it with the black line (total demand) it can be seen that demand has increased. Increased demand, i.e. increased energy consumption, entails increased power generation and thus increased Total System Cost (TSC) and Total System Emissions (TSE). In addition, increase in TSC is the result of running more expensive units to cover the higher demand. The third reason is larger requirements for up reserve, in particular scheduling of more OCGT units. Cheaper coal and CCGT units during peak periods are providing energy so OCGT units are required to provide reserve. Increased production from gas turbines does not necessarily mean the increase in TSE since the emissions rate of OCGT is lower than that of coal. Down reserve is provided purely from coal units same as in the base case.

In the third case scenario uncontrolled charging results in additional reserve requirements (UCH-YR case); this can be easily explained by the difficult to predict arrival time and difficult to predict state of charge of EV's batteries. To cover this new reserve demand, new units need to be online to provide it. Although no additional energy is required, OCGT units need to be scheduled to cover energy demand during weekly minimum to be able to correspondingly provide more reserve. Higher reserve requirements, provided by OCGT, in addition to running expensive OCGT to



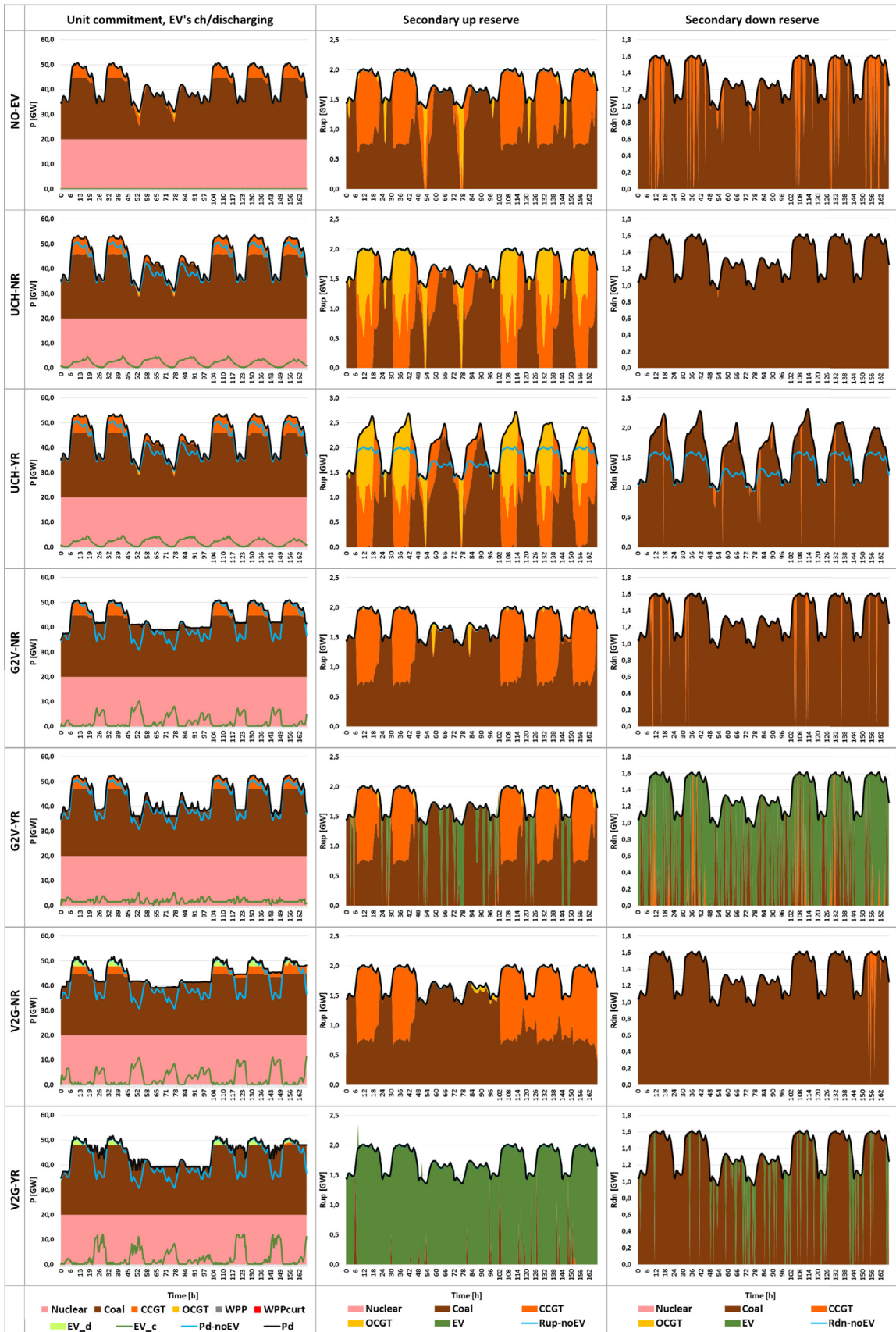

Fig. 4. ColnFl system results.

**Table 2**  
Scenarios generation mixes.

Generation type <sup>a</sup>	Thermal power plants (TPP)				Hydro power plant (HPP)		
	Nuclear (%)	Coal (%)	CCGT (%)	OCGT (%)	CHPP (%)	RoR (%)	PS (%)
InTh	35	45	15	5	0	0	0
FlTh	15	25	45	15	0	0	0
HyTh	20	20	15	0	15	15	15

<sup>a</sup> Percentage of totally needed generation capacity to cover demand, reserve and primary control requirements.

provide energy, means increase in TSC and slight decrease in TSE (less power is produced from more emission intensive coal).

The fourth scenario analyses the controllable EV scenario, where EV can only be charged from the power system. G2V-NR mode follows different charging pattern compared to that in UCH as shown in Fig. 4. EVs are charged at low-demand periods (at night and weekends) and this results in the lower TSC and highest system benefits. Coordinated charging results in more evenly distributed generation and consumption and, due to lower number of unit's start-up and shut-downs, lower TSC. In addition, the flexible EV charging had an impact on both up and down reserves requirements resulting in lower demand when compared to previous two cases.

In the fifth analysed scenario controllable EVs can provide both energy and reserve, this is G2V-YR scenario mode. Unlike the previous case the charging does not occur only during the night, it is rather uniformly distributed through the day during the entire week. TSC is lower than in all previous scenarios since EV's will be assigned to provide secondary reserve instead of more expensive coal, CCGT or OCGT units. Another interesting phenomenon, associated with G2V-YR mode, is a slight increase in TSE. Since coal power plants do not provide down reserve they are scheduled to operate at technical minimum during low demand periods. Although this is less costly than to work at full power, the emissions rate (expressed as  $tCO_2/MW h$ ) is higher. Also, assigning less up reserve to coal units means they will participate more in energy provision during peak periods, resulting in higher total system emissions.

The sixth scenario allows both controlled charging and discharging in V2G-NR mode. It can be easily noticed that TSC additional decreases, compared to G2V-NR mode, due to back-to-grid power injections during peak periods. Although total energy demand is higher in this scenario since part of the energy is lost due to charging/discharging efficiencies, but more energy is generated by lower cost units. Energy discharged by EVs is shown with light green area in Fig. 4 and can be noticed particularly during peak demand periods. EVs are being charged during low demand periods resulting in even more flattened net demand curve. An interesting observation is that G2V-YR mode has lower TSC than V2G-NR mode, which is mostly caused by more energy that needs to be generated by thermal units in the latter case. The same can be noticed for TSE.

The seventh scenario allows controlled EV charging and discharging and participation in both energy and reserve services. This scenario is characterized with the lowest TSC. Coal units are being replaced completely from providing up reserve which enables them to operate at optimum operation point for provision of energy. In addition, CCGT and OCGT units are completely shut down since EVs replace their flexibility services. EV's charging and discharging patterns are very similar to those from V2G-NR mode. Up reserve is completely covered by EVs, while a small portion of down reserve is still covered by coal. This can be explained by practical reasons: if coal power plants are run for provision of

energy as this is the less cost option, it makes sense to use their capability to provide down reserve. EV's are charged/discharged during optimal periods during the day so the algorithm does not assign them provision of down reserve. Although TSC is the lowest, TSE reaches highest value of all observed scenarios since most of the energy generated comes from highly pollutant coal units.

#### 4.1.2. Low carbon inflexible thermal system (LoInFl)

Studies in this subsection are similar to those in the previous one, with addition of wind power plants (WPP) and additional reserve requirements caused by this variable and uncertain source. The system scheduling is analysed in details for WPP integration of 20% (12 GW for the observed system). Weekly wind power production (for a high wind generation week) pattern is displayed in Fig. 1. Wind power production increases the required reserve as shown in Eqs. (8)–(10). Fig. 7 displays EV's charging and discharging behaviour, energy provision from thermal power plants as well as contributions of secondary up and down reserve assigned to different units of LoInTh system. Conceptually all graphs in the Fig. 7 follow the same logic as those in the previous subsection. The only new variables in Fig. 7 are that of wind power production. Grey area represents actual power generated by wind power plants and it is displayed beneath load demand curve (black line). Red area represents curtailed wind power and it is displayed above power demand curve since it is not being used and should be seen as insufficient flexibility of the observed system. Since all scenarios are same as those in the previous section, most of the explanations are very similar so only the differences between the two cases will be highlighted. Whereas in the last chapter flexibility metrics were TSC and TSE, in this chapter wind curtailment is added to those two.

In the base case (NO-EV) Wind Power Production (WPP) is fully exploited during weekday's peak periods, while it is curtailed (WPcurt) during low demand periods, at night and weekends. Comparing it to the previous section simulations, it can be seen that expensive units, OCGT and CCGT, have been replaced by WPP in energy provision. Reserve requirements in both directions are almost completely covered with coal (gas turbines are not online so they are not able to provide spinning reserve service). Gas turbines are scheduled to provide up reserve during few specific periods, when there is either not enough coal or coal is shut down due to low demand and therefore fast response units are scheduled to substitute the coal.

If the first scenario is upgraded with the addition of inflexible EVs (UCH-NR scenario), electricity demand is higher and less wind is curtailed. Although there is an increase in TSC and TSE, the values are lower than in the previous section when the same EVs charging mode was analysed but without wind. This can be simply explained; less curtailed wind means lower generation from expensive and environmentally less friendly thermal power generation. CCGT's up reserve provision during peak periods has increased (higher demand – less coal available to provide reserve), however OCGT scheduled to provide reserve have decreased their provision during low demand periods (higher demand means more coal is scheduled to provide energy and therefore is also available for reserve provision).

Scenario two, UCH-YR mode, results in higher TSC, TSE and wind curtailment. Larger reserve requirements caused by variability and uncertainty of both wind and EV, suggest higher number of scheduled units.

Flexibility of EVs in G2V-NR mode, allows higher WPP to be accommodated; lower wind curtailment also means lower thermal power generation and, correspondingly, lower TSC and TSE. EV's are being charged during periods when otherwise wind power would be curtailed. The flexibility of EV to be charged when it

benefits the system also reduces the need for gas turbines energy and reserve provision.

Allowing EVs to provide reserve (G2V-YR) further increases system's flexibility since zero wind is curtailed and provision of energy and reserves from gas turbines is minimized. This in turn also means TSE and TSC is additionally reduced. Similar to the analyses in the previous section, it can be seen that EVs charging is evenly distributed throughout week. Since EVs are completely providing down reserve and most of the up reserve, coal units are able to ramp up or down from technical minimum to full power, enabling them to work at their optimal operating points (which is not the case when they have to provide reserve services).

As it can be seen from analyses of scenario six, V2G-NR mode is not able to utilize all available wind power thus very small wind curtailment exist during low demand weekend periods. Periods of EV charging are very similar to those of G2V-NR mode and to V2G-NR mode of previous section while discharging rarely happens due to production from WPP (which was not the case in previous section analyses). Two direction roles of EV results in reserve being provided only by coal units.

Last operating mode is the most flexible one where no wind is curtailed, similar to G2V-YR mode. Although the system behaviour in G2V-YR and V2G-YR modes is similar, the V2G mode has lower TSC as it could be seen at Fig. 6. Major difference is that V2G mode have the possibility to discharge. Discharging is, similar to previous case, almost zero and even though that possibility is not being used for provision of energy, this capability contributes to rescheduling of up reserve which is completely provided by EVs as displayed at Fig. 7. Consequently, coal power plants have less start-ups, shut-downs and ramping and thus TSC is lower. Still the same amount of energy is generated by coal so the TSE is the same as in G2V-YR scenario (Fig. 6).

#### 4.1.3. Discussion and conclusion

The analyses in Section 4.1.1 show that the most expensive case for the power system operations is the one when integrating uncontrollable charging EVs, in particular when difficulties of predicting their time and power/energy demand as this results in increased reserve requirements. Uncontrolled charging requires new peak units to be started and new reserve providing units compared with NO EV scenario. Controlled charging could alleviate provision of these services from low efficient and environmentally unfriendly units to low carbon system. It is clear that controlled charging is improving power systems stability as power demand diagram becomes more flattened, i.e. less ramping and start-ups occur in normal daily operations (Fig. 4). It could be seen from Fig. 5 that TSC line decreases when EV's introduce new flexibility services to system operation. The most promising operational mode appears to be V2G-YR mode where valleys in power demand diagram almost correspond to high peaks and TSC is the lowest of all observed operational modes. However, two main issues need to be kept in mind when considering V2G charging mode. Power injections, or constant cycling caused by changing and discharging, could harm and reduce the lifetime of EV's battery. In addition, using EVs as both source and sink of energy results in the increase in TSE. From Fig. 5 it can be noticed that, opposite to TSC, TSE curve has constant increase. It appears that EV's flexibility enhancement negatively affect system TSE. For a power system whose energy mix is based on fossil fuel driven power plants it can be concluded that TSC and TSE are mutually opposed variables and that integrating controllable loads will challenge the environmental policies. Situation improves with the simultaneous integration of RES. This is demonstrated through a set of studies in Section 4.1.2 where 20% of wind power plants is included.

Analyses in Section 4.1.2 define three parameters for defining the systems flexibility; on top of the TSC and TSE (Fig. 6), wind

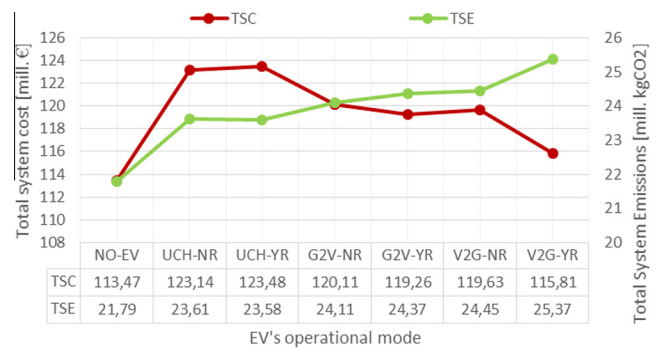

Fig. 5. Total system cost and emissions for ColnTh system.

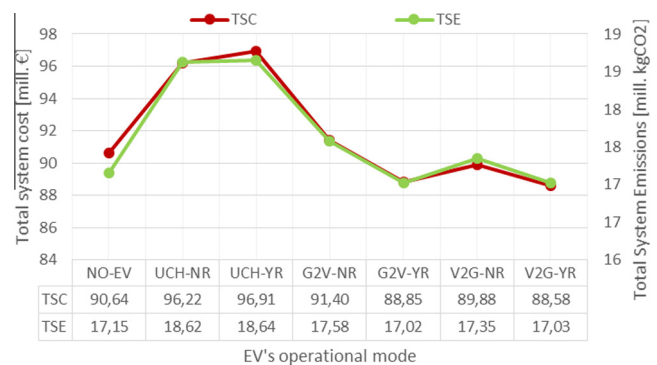

Fig. 6. Total system cost and emissions for LolnTh system.

curtailment serves as a metric of insufficient system flexibility (Fig. 8). The worst case for power system operations, in terms of flexibility metrics TSC, TSE and wind curtailment, is UCH-YR mode. It is clear that this kind of EV's charging should be avoided. Similar to the previous scenario, with no wind in the system, TSC decreases when EV's introduce new flexibility services to power system operation providing energy and reserve, but, unlike in the previous scenarios, TSE also decreases. More precisely TSE and TSC have the same pattern of behaviour. This is a positive change and aforementioned problem of TSE increase is solved. Wind curtailment decreases even in UCH modes, but major decrease is when controllable modes are observed. G2V-YR and V2G-YR fully exploit WPP, meaning that wind curtailment is zero in both modes. The latter control mode, V2G-YR, is an excellent example of flexibility enhancement gained by EV's reserve provision. Another problem mentioned in the previous analyses is discharging effect on battery's life cycle. This problem is indirectly solved by WPP integration, since V2G-YR mode uses option of EVs discharge just for up reserve provision and not for energy service provision, resulting in a lower number of EV battery cycles.

#### 4.2. Benefits of EV participation in spinning reserve provision with respect to power system energy mix

Although the results in the previous chapter provide an insight into benefits of integrating EV for provision of various services, their behaviour is highly dictated by flexibility of the existing power plants in the power systems energy mix. For this reason, additional analyses will be provided focusing on EVs and RESs (WPP) interaction for different energy mix systems.

Following on the results from the previous section, the focus will be only on G2V-NR and G2V-YR charging modes. Figs. 9, 11 and 13 display power system's savings caused by EV's reserve provision capabilities. The Y axis shows "savings" calculated as the difference of TSC for a system where EVs can provide



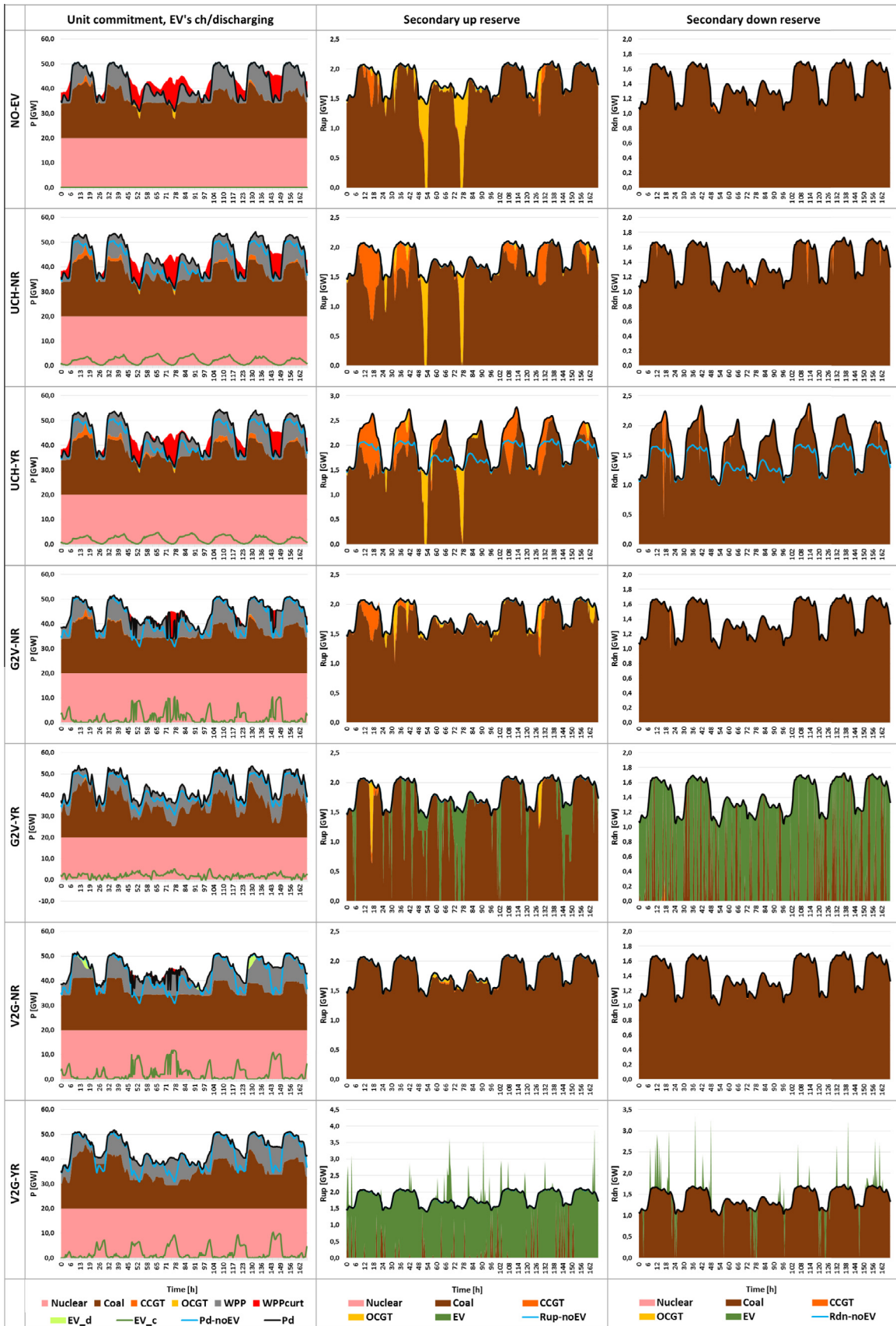

Fig. 7. IolnFl system results.

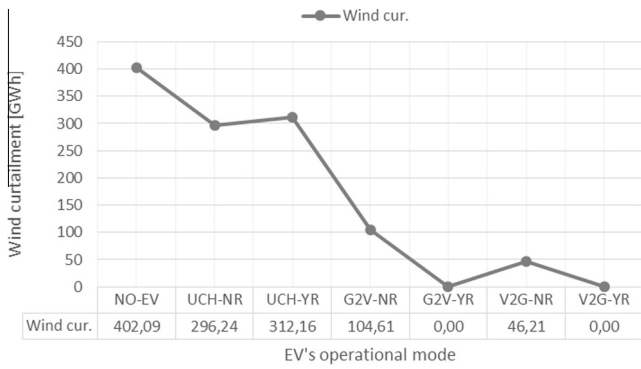

Fig. 8. Wind curtailment for InTh system.

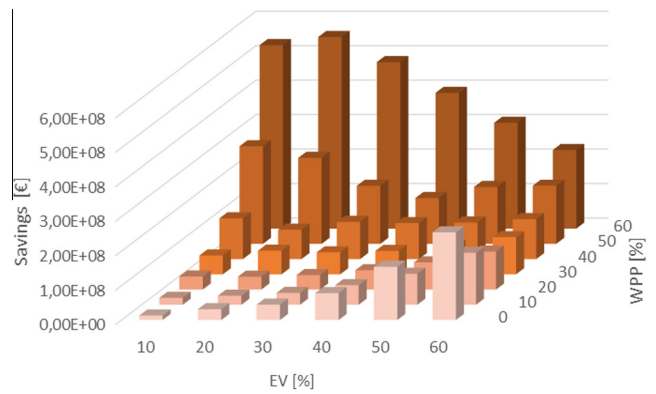

Fig. 11. System savings for FiTh system.

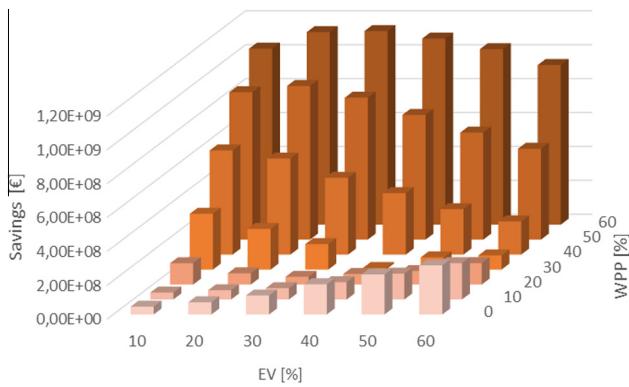

Fig. 9. System savings for InTh system.

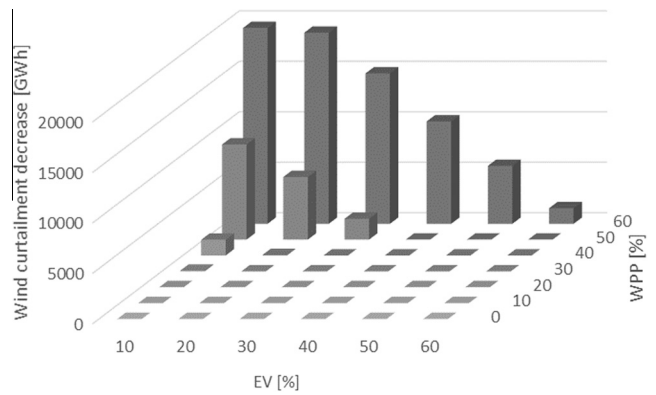

Fig. 12. Wind curtailment for FiTh system.

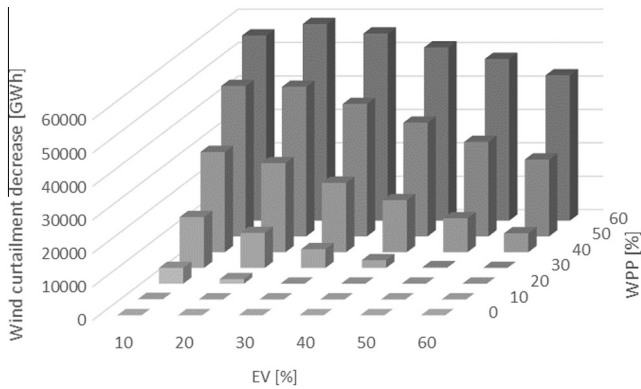

Fig. 10. Wind curtailment for InTh system.

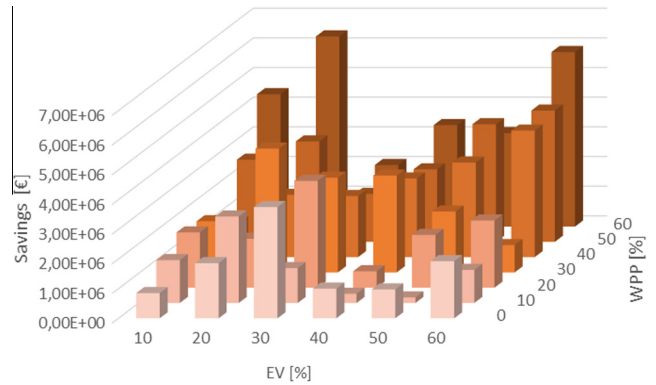

Fig. 13. System savings for HyTh system.

reserve to the one where they cannot. In addition, Figs. 10 and 12 display wind curtailment decrease as the results of EV's additional capability to provide reserve services. The analyses are shown for seven different cases of EVs and WPPs penetration ranging from 0% to 60% in 10% step increase. It provides the analyses for three different scenarios: Inflexible Thermal (InTh), Flexible Thermal (FiTh) and Hydro-Thermal (HyTh) system. Each systems energy mix and belonging characteristics are elaborated next to the results.

First two figures correspond to the InTh system which was analysed in the previous section. When there is no wind or in scenarios when wind penetration is low (<20%), higher EVs penetration results in larger savings. New flexibility introduced by EVs reserve

provision capabilities is “relaxing” coal reserve constraints and they can ramp up and down more freely; in other words EVs flexibility has been mitigated to coal units. Still, the mentioned savings are relatively small compared to TSC. Higher wind penetration (>30%) shows different TSC savings behaviour. It can be easily noticed that for different wind penetration percentage there is an “optimal” EVs percentage when savings are the highest. It can be seen that those optimal points are placed in areas of low EVs penetration, e.g. for 40% WPP optimal EVs penetration level is 10%. When more WPP is included optimal points move to higher EVs penetration levels, e.g. for 60% WPP optimal EVs penetration level is 30%. More WPP means more wind curtailment and EV's capability to provide reserve is no longer used just for substituting coal

power plants role in reserve scheduling, rather for decreasing wind curtailment. This can be easily seen in Fig. 10 where wind curtailment is reduced as EV share increases. It should be noted that the algorithm does not penalize wind curtailment, as in some publications [9], in order to give more realistic results.

The second analyses focus on a more flexible system still dominated by thermal power plants, the FITh system. The size of the system, in terms of demand, is the same to make the results comparable. In addition, compared to InTh system, FITh system has less nuclear and coal units and relies more gas turbine power plants, as shown in Table 2. The first thing that can be noticed comparing Figs. 11 and 13, is that TSC savings are much lower in FITh system. Highest saving for InTh is 1.14 billion € (this accounts for 23.1% to TSC in InTh), while for FITh this value is 0.56 billion € (for comparison, this is 9.5% of the TSC for FITh). Similar case is with wind curtailment in Figs. 10 and 12. Highest wind curtailment reduction for InTh system is 58.83 TW h (85%), while in FITh it is 19.4 TW h (80%), which clearly shows how InTh gains more by new flexibility providers, EV. For the more flexible system, FITh, wind curtailment occurs only for 50% or more WPP. FITh, due to its higher flexibility, can utilize most of integrated WPP even without EV and their reserve capabilities. When there is no wind or wind penetration is low (<20%), higher EVs penetration causes higher TSC savings (savings are again expressed as scenarios when EV can provide reserve services to that where they cannot) for the same reason as in InFl system. For 40–50% of WPP share, higher values of TSC savings happen for very low and very high EVs penetration. TSC savings for highest WPP share analysed, 60%, are very similar to 50% WPP share in InTh system.

The third analyses discuss flexibility enhancement by EVs reserve provision in highly flexible hydro-thermal power system (HyTh). The share of thermal and hydro units in this system is about the same and covers 50% of total installed power capacities. Due to flexible hydro power plants (RoR hydro power plants are modelled to have accumulation of few hours while CHPP can have accumulation of 2 days) and pump-storage power plants (modelled with upper reservoir accumulation of 2.5 days and lower reservoir accumulation of 1 day) WPP is fully exploited even for high WPP penetration levels (60%), meaning wind curtailment for all analysed cases is zero. Highest saving for this system is 6.41 mill. € (0.5% of the TSC for HyTh system) and is significantly lower when compared to savings in first two cases. In Fig. 13 it can be seen that no uniform conclusion in terms of savings exist as it was the case in previous two analyses. High inherited flexibility of hydro units and new flexibility enhancement of EVs ensure sufficient low-price reserve provision even without EVs reserve provision. Irregularity in gained savings (Fig. 13) occurs since reserve provision from both hydro and EVs have similar benefits to system; none or very small additional cost occurs when reserve is provided either from hydro or EVs.

## 5. Concluding remarks

The results and analyses presented in the paper clearly show EV uncontrolled charging should be rigorously avoided as it creates additional costs and increases emissions compared to the systems where there is no EV. On the other hand it can be clearly seen how controlled charging strategies, even without discharging and/or reserve provision capabilities, decrease overall system cost and wind curtailment and, at the same time, increase the EPS's capability to integrate variable and uncertain sources. Additional discharging and reserve capabilities further improve EPS operations and further reduces overall system cost and wind curtailment. A key finding of the paper is that EV capability to provide spinning reserve introduces additional flexibility to EPS displacing high cost and emission units. An interesting results can be noticed for G2V mode (charging only) with the capability to provide reserve, when compared to V2G mode (both charging and discharging capability) without option to participate in reserve services. The first option outperforms the second one, and its performance is comparable to that of V2G with capability to provide both reserve and energy services.

The savings gained, both in terms of cost and CO<sub>2</sub> emissions, are a result of shifting the scheduling of energy and spinning reserve services from coal and gas power plants to EV. By doing this, the fossil fuel based power plants are either turned off or are operating closer to their optimal operating points, unlike in the scenarios when they have the task to alleviate issues caused by variable and uncertain wind generation.

The paper additionally contributes by clearly recognizing EVs contribution to flexibility for different power systems energy mix. While these benefits are rather high for inflexible systems, such as the one of UK, both in terms of operational cost, environmental benefits and reduced wind curtailment, they are significantly lower for already flexible systems. From the results it can be clearly seen that low flexible systems would benefit greatly from EV participation in both energy and reserve services, with the TSC reduction of 23.1% and wind curtailment reduction of 80%, while for already highly flexible systems these savings are almost negligible and are below 1% of total system cost.

## Acknowledgments

The work of the authors is a part of the Flex-ChEV – Flexible Electric Vehicle Charging Infrastructure project funded by Smart Grids ERA-Net under project grant No. 13 and FENISG – Flexible Energy Nodes in Low Carbon Smart Grid funded by Croatian Science Foundation under project grant No. 7766.

## Appendix A

See Tables 3 and 4.

**Table 3**  
Thermal units parameters.

Technology	$P_{min}$ (MW)	$E_{i1}$ (MW)	$E_{i2}$ (MW)	$P_{max}$ (MW)	$C_{n1}$ (\$/h)	$C_{in1}$ (\$/MW h)	$C_{in2}$ (\$/MW h)	$C_{in3}$ (\$/MW h)	$C_{st}$ (\$)	$C_{sh}$ (\$)	$T_{up}$ (h)
Nuclear	400	400	400	400	260.865	12.093	12.663	13.233	750	75	16
Coal	140	210	280	350	199.435	17.0805	17.3955	17.7105	450	45	8
CCGT	68.9	111.6	154.3	197	359.485	35.3535	35.6865	36.0195	300	30	5
OCGT	4	9.3	14.7	20	176.925	56.937	57.1545	57.3735	46	4.6	0.5
	$T_{dn}$ (h)	$V_{up}$ (MW/h)	$V_{dn}$ (MW/h)	$P_0$ (MW)	$N_0$	$RHO_{up}$	$RHO_{dn}$	$F_{iup}$ (MW)	$F_{idn}$ (MW)	Emiss. (kgCO <sub>2</sub> /MW h)	Start emiss. rate (kgCO <sub>2</sub> )
Nuclear	10	50.5	100	12,000	30	0.5	0.5	40	40	0	0
Coal	5	70	120	10,500	30	0.4	0.4	35	35	925	25,000
CCGT	4	55	99	0	0	0.6	0.6	19.7	19.7	394	8000
OCGT	0.5	30.5	70	0	0	0.7	0.7	2	2	600	3000

**Table 4**  
Hydro units parameters.

Techn.	$P_{min}$ (MW)	$P_{max}$ (MW)	$H_{min}$ (m)	$H_{max}$ (m)	$Q_{min}$ (m <sup>3</sup> /s)	$Q_{max}$ (m <sup>3</sup> /s)	$V_0$ (m <sup>3</sup> )	$V_k$ (m <sup>3</sup> )	etah	kv	$T_{ak}$ (d)	$C_{nl}$	$C_{in}$
Run-of-river	10	60	0	100	15	60	2.16E+05	8.64E+05	0.9	1	0.167	20	1
CHPP	100	250	0	238	50	120	5.25E+06	2.10E+07	0.9	1	2.025	200	1.5
	$P_{gmin}$ (MW)	$P_{gmax}$ (MW)	$H_{gmi}$ (m)	$H_{gma}$ (m)	$Q_{gmin}$ (m <sup>3</sup> /s)	$Q_{gmax}$ (m <sup>3</sup> /s)	$V_{0up}$ (m <sup>3</sup> )	$V_{kup}$ (m <sup>3</sup> )	etag	kv	$T_{akup}$ (d)		
PS	33	275	0	519	0	60	0	12,650,000	0.9	0.99	2.44020062		
	$C_{nl}$	$C_{in}$	$P_{pmi}$ (MW)	$P_{pma}$ (MW)	$H_{pmin}$	$H_{pmax}$	$Q_{pmin}$	$Q_{pmax}$	$V_{odn}$ (m <sup>3</sup> )	$V_{kdn}$ (m <sup>3</sup> )			
PS	200	1.5	35	140	0	519	0	40	84,000	3,500,000			

## References

- Pavić I, Capuder T, Holjevac N, Kuzle I. Role and impact of coordinated EV charging on flexibility in low carbon power systems. In: 2014 IEEE international electric vehicle conference (IEVC); 2014. p. 1–8.
- Ummels BC, Gibescu M, Pelgrum E, Kling WL, Brand AJ. Impacts of wind power on thermal generation unit commitment and dispatch. *IEEE Trans Energy Convers* 2007;22(1):44–51.
- Capuder T, Mancarella P. Techno-economic and environmental modelling and optimization of flexible distributed multi-generation options. *Energy* 2014;71:516–33.
- Kling WL, Pelgrum E, Ummels BC. Integration of large-scale wind power and use of energy storage in the Netherlands' electricity supply. *IET Renew Power Gener* 2008;2(1):34–46.
- Amoli NA, Sakis Meliopoulos AP. Operational flexibility enhancement in power systems with high penetration of wind power using compressed air energy storage. In: 2015 Clemson University power systems conference (PSC); 2015. p. 1–8.
- Arteconi A, Hewitt NJ, Polonara F. State of the art of thermal storage for demand-side management. *Appl Energy* 2012;93:371–89.
- Pandzić H, Wang Y, Qiu T, Dvorkin Y, Kirschen DS. Near-optimal method for siting and sizing of distributed storage in a transmission network. *IEEE Trans Power Syst* 2014;30:1–13.
- Hatziaargyriou N, Asano H, Iravani R, Marnay C. Microgrids. *IEEE Power Energy Mag* 2007;5(4):78–94.
- Holjevac N, Capuder T, Kuzle I. Adaptive control for evaluation of flexibility benefits in microgrid systems. *Energy* 2015;10:10.
- Dietrich K, Latorre JM, Olmos L, Ramos A. Demand response in an isolated system with high wind integration. *IEEE Trans Power Syst* 2012;27(1):20–9.
- Alizadeh M, Scaglione A, Goldsmith A, Kesidis G. Capturing aggregate flexibility in demand response. In: 53rd IEEE conference on decision and control; 2014. p. 6439–45.
- International Energy Agency. 2014 Key World Energy STATISTICS; 2014.
- Pathways to high penetration of electric vehicles. Final report for the committee on element energy; 2013.
- Block D, Harrison J, Dunn MD. Electric vehicle sales and future projections; 2014.
- Trigg T, Telleen P, Boyd R, Cuenot F. Global EV outlook: understanding the electric vehicle landscape to 2020; 2013.
- Quinn C, Zimmerle D, Bradley TH. The effect of communication architecture on the availability, reliability, and economics of plug-in hybrid electric vehicle-to-grid ancillary services. *J Power Sources* 2010;195(5):1500–9.
- White CD, Zhang KM. Using vehicle-to-grid technology for frequency regulation and peak-load reduction. *J Power Sources* 2011;196(8):3972–80.
- Kang J, Duncan SJ, Mavris DN. Real-time scheduling techniques for electric vehicle charging in support of frequency regulation. *Proc Comput Sci* 2013;16:767–75.
- Freund D, Lützenberger M, Albayrak S. Costs and gains of smart charging electric vehicles to provide regulation services. *Proc Comput Sci* 2012;10:846–53.
- Tomić J, Kempton W. Using fleets of electric-drive vehicles for grid support. *J Power Sources* 2007;168(2):459–68.
- Liu H, Hu Z, Song Y, Lin J. Decentralized vehicle-to-grid control for primary frequency regulation considering charging demands. *IEEE Trans Power Syst* 2013;28(3):3480–9.
- Li VOK. Online scheduling for vehicle-to-grid regulation service. In: 2013 IEEE international conference on smart grid communications (SmartGridComm); 2013. p. 43–8.
- Liu H, Hu Z, Song Y, Wang J, Xie X. Vehicle-to-grid control for supplementary frequency regulation considering charging demands. *IEEE Trans Power Syst* 2015;PP(99):1–10.
- Huang S, Wu L, Infield D, Zhang T. Using electric vehicle fleet as responsive demand for power system frequency support. In: 2013 IEEE vehicle power and propulsion conference (VPPC); 2013. p. 1–5.
- Ortega-Vazquez MA, Bouffard F, Silva V. Electric vehicle aggregator/system operator coordination for charging scheduling and services procurement. *IEEE Trans Power Syst* 2013;28(2):1806–15.
- Sanchez-Martin P, Lumbrellas S, Alberdi-Alen A. Stochastic programming applied to EV charging points for energy and reserve service markets. *IEEE Trans Power Syst* 2015;PP(99):1–8.
- Reddy KS, Panwar LK, Kumar R. Potential benefits of electric vehicle deployment as responsive reserve in unit commitment. In: 2014 9th International conference on industrial and information systems (ICIIS); 2014. p. 1–6.
- Sortomme E, El-Sharkawi MA. Optimal scheduling of vehicle-to-grid energy and ancillary services. *IEEE Trans Smart Grid* 2012;3(1):351–9.
- Keane E, Flynn D. Potential for electric vehicles to provide power system reserve. In: 2012 IEEE PES innovative smart grid technologies (ISGT); 2012. p. 1–7.
- Verzijlbergh R, Brancucci Martínez-Anido C, Lukszo Z, de Vries L. Does controlled electric vehicle charging substitute cross-border transmission capacity? *Appl Energy* 2014;120:169–80.
- Schuller A, Flath CM, Gottwalt S. Quantifying load flexibility of electric vehicles for renewable energy integration. *Appl Energy* 2015;151:335–44.
- Jian L, Zheng Y, Xiao X, Chan CC. Optimal scheduling for vehicle-to-grid operation with stochastic connection of plug-in electric vehicles to smart grid. *Appl Energy* 2015;146:150–61.
- Rangaraju S, De Vroey L, Messagie M, Mertens J, Van Mierlo J. Impacts of electricity mix, charging profile, and driving behavior on the emissions performance of battery electric vehicles: a Belgian case study. *Appl Energy* 2015;148:496–505.
- Xiao G, Li C, Yu Z, Cao Y, Fang B. Review of the impact of electric vehicles participating in frequency regulation on power grid. In: 2013 Chinese automation congress; 2013. p. 75–80.
- FICO Xpress optimization suite. Available: <<http://www.fico.com/en/>>.
- Palmintier BS, Webster MD. Heterogeneous unit clustering for efficient operational flexibility modeling. *IEEE Trans Power Syst* 2014;29(3):1089–98.
- Aunedi M. Value of flexible demand-side technologies in future low-carbon systems. Imperial College London; 2013.
- Gross R, Green T, Leach M, Skea J, Heptonstall P, Anderson D. The costs and impacts of intermittency; 2006.
- National grid. Winter outlook 2013/14; 2013.
- Rebours Y, Kirschen DS. A survey of definitions and specifications of reserve services; 2005.
- Ma J, Silva V, Belhomme R, Kirschen DS, Ochoa LF. Evaluating and planning flexibility in sustainable power systems. In: 2013 IEEE power & energy society general meeting; 2013. p. 1–11.
- Silva V. Value of flexibility in systems with large wind penetration. University of London; 2010.
- Pudjianto D, Aunedi M, Djapic P, Strbac G. Whole-systems assessment of the value of energy storage in low-carbon electricity systems. *IEEE Trans Smart Grid* 2014;5(2):1098–109.
- Quan H, Srinivasan D, Khambadkone AM, Khosravi A. A computational framework for uncertainty integration in stochastic unit commitment with intermittent renewable energy sources. *Appl Energy* 2015;152:71–82.
- Dimitroulas DK, Georgilakis PS. A new memetic algorithm approach for the price based unit commitment problem. *Appl Energy* 2011;88(12):4687–99.
- Wang J, Wang J, Liu C, Ruiz JP. Stochastic unit commitment with sub-hourly dispatch constraints. *Appl Energy* 2013;105:418–22.
- Basilis CG, Bakirtzis AG. Optimal yearly scheduling of generation and pumping for a price-maker hydro producer. In: 2010 7th International conference on the European energy market; 2010. p. 1–6.
- Van Haaren R. Assessment of electric cars' range requirements and usage patterns based on driving behavior recorded in the National Household Travel Survey of 2009; 2011.
- Department for transport. Vehicle licensing statistics: quarter 3 (July–September) 2014; 2014.

## Publication 2

I. Pavić, T. Capuder, and I. Kuzle, “Low carbon technologies as providers of operational flexibility in future power systems,” *Applied Energy*, vol. 168, pp. 724–738, Apr. 2016, ISSN: 0306-2619. DOI: 10.1016/J.APENERGY.2016.01.123



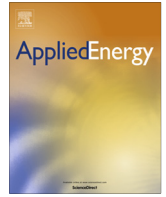

# Low carbon technologies as providers of operational flexibility in future power systems



Ivan Pavić\*, Tomislav Capuder, Igor Kuzle

University of Zagreb Faculty of Electrical Engineering and Computing, Unska 3, Zagreb, Croatia

## HIGHLIGHTS

- Mixed integer linear programming model for provision of multiple services from EV.
- EV energy and reserve services provision effects on power system operation.
- Impacts of conventional unit's decommission on system's operation and flexibility.
- Assessment of power system's flexibility under different wind generation polices.

## ARTICLE INFO

### Article history:

Received 17 November 2015

Received in revised form 29 January 2016

Accepted 30 January 2016

### Keywords:

Ancillary services

Electric vehicles

Flexibility

Power plant decommissioning

Reserve services

Wind curtailment

## ABSTRACT

The paper presents a unit commitment model, based on mixed integer linear programming, capable of assessing the impact of electric vehicles (EV) on provision of ancillary services in power systems with high share of renewable energy sources (RES). The analyses show how role of different conventional units changes with integration of variable and uncertain RES and how introducing a flexible sources on the demand side, in this case EV, impact the traditional provision of spinning/contingency reserve services. In addition, technical constraints of conventional units, such as nuclear, gas or coal, limit the inherit flexibility of the system which results in curtailing clean renewable sources and inefficient operation. Following on that, sensitivity analyses of operational cost and wind curtailment shows which techno-economic constraints impact the flexibility of the high RES systems the most and how integration of more flexible units or decommission of conventional nuclear, coal and gas driven power plants would impact the system's operation. Finally, two different wind generation polices (wind penalization and wind turbines as reserve providers) have been analysed in terms of operational flexibility through different stages of conventional unit's decommission and compared with the same analyses when EV were used as reserve providers.

© 2016 Elsevier Ltd. All rights reserved.

## 1. Introduction

Emerging integration of so called low carbon technologies (LCT), which are considered to be the essential link in creation of sustainable energy future, redefines operation and planning concepts of traditional energy systems. As the environmental goals of reducing CO<sub>2</sub> emissions drive the energy regulatory frameworks toward “all electric” systems by stimulating electrification of heat and transport, power system operators face the challenge of planning and operating increasingly variable and uncertain power systems [1]. While electric vehicles (EV) and, potentially, electrified heating (EH) act as sources of the variability and uncertainty from the

demand side [2] integration of renewable energy sources additionally contributes to this from the supply side [3]. To alleviate the uncertain and variable nature of renewable energy sources (RES) new sources of flexibility become of critical value. Number of studies address the integration of different energy storage technologies (ES) [4–6] or demand response programs (DR) [7,8], but they rarely address the impact on power system operation planning and scheduling and how their integration impacts the existing generation units role in the system.

The capability of EV to participate in provision of energy arbitrage, ancillary services, as well as on their impact on distribution and transmission grid has gained much attention in recent literature. The authors in [9] proposed a multi-objective optimization model assessing the impact of EV on distribution grid, clearly showing how controlled charging in regards to uncontrolled brings benefits to daily distribution grid operation in multiple technical

\* Corresponding author.

E-mail addresses: [ivan.pavic@fer.hr](mailto:ivan.pavic@fer.hr) (I. Pavić), [tomislav.capuder@fer.hr](mailto:tomislav.capuder@fer.hr) (T. Capuder), [igor.kuzle@fer.hr](mailto:igor.kuzle@fer.hr) (I. Kuzle).

## Nomenclature

### Decision variables

$p_{t,i}^{g\_TP}$	thermal units generation
$p_{t,i}^{g\_HP}$	hydro units generation
$p_{t,i}^{g\_PS}$	pump storage generation/pumping
$p_{t,i}^{p\_PS}$	pump storage pumping
$p_t^{g\_WP}$ , $p_t^{curt\_WP}$	wind power generation, wind power curtailment
$p_{t,i}^{c\_EV}$ , $p_{t,i}^{d\_EV}$	electric vehicles slow charging/discharging
$p_{t,i}^{f\_EV}$	electric vehicles fast charging
$f_{t,i}^{up\_TP}$ , $f_{t,i}^{dn\_TP}$ , $r_{t,i}^{up\_TP}$ , $r_{t,i}^{dn\_TP}$	thermal units primary(f)/secondary(r) up/down reserve provision
$f_{t,i}^{up\_HP}$ , $f_{t,i}^{dn\_HP}$ , $r_{t,i}^{up\_HP}$ , $r_{t,i}^{dn\_HP}$	hydro units primary(f)/secondary(r) up/down reserve provision
$f_{t,i}^{up\_PS}$ , $f_{t,i}^{dn\_PS}$ , $r_{t,i}^{up\_PS}$ , $r_{t,i}^{dn\_PS}$	pump storage primary(f)/secondary(r) up/down reserve provision
$f_{t,i}^{up\_EV}$ , $f_{t,i}^{dn\_EV}$ , $r_{t,i}^{up\_EV}$ , $r_{t,i}^{dn\_EV}$	electric vehicles primary(f)/secondary(r) up/down reserve provision
$f_t^{up\_WP}$ , $r_t^{up\_WP}$	wind turbines primary(f)/secondary(r) up reserve provision
$q_{t,i}^{up\_TP}$	thermal units tertiary up reserve provision
$c_{t,i}^{TP}$	total thermal power plant cost
$c_{t,i}^{HP}$	total hydro power plant cost
$c_t^{curt\_WP}$	wind power curtailment cost

### Input parameters

$P_t^d$	power demand
$F_t^{up}$	primary up reserve requirements
$F_t^{dn}$	primary down reserve requirements
$R_t^{up}$	secondary up reserve requirements
$R_t^{dn}$	secondary down reserve requirements
$Q_t^{up}$	tertiary up reserve requirements
$P_t^{-WP}$	potential wind power generation

$PF^{curt\_WP}$	penalty factor for wind power curtailment
$R_t^{EV\_0.5h}$ , $R_t^{EV\_4h}$	secondary and tertiary reserve requirements increase caused by uncontrolled EVs charging
$\sigma_t^{sl(0.5h)\_EV}$ , $\sigma_t^{sl(4h)\_EV}$	EVs uncontrolled charging standard deviation for secondary and tertiary reserve
$\sigma_t^{(0.5h)\_WP}$ , $\sigma_t^{(4h)\_WP}$	wind power standard deviation for secondary and tertiary reserve

### Input parameters

Ni_TP	number of thermal technology types
Ni_HP	number of hydro technology types
Ni_PS	number of pump storage technology types
Ni_EV	number of electric vehicles types
$\sigma^d$	power demand standard deviation
$p_{gmax}$	the largest online unit in power system
$\Delta t$	time period (0.5 h) for energy calculation
$S_i^{0\_EV}$	energy conserved in (all) EVs in time step zero

### Abbreviations

CCGT	combined cycle gas turbine
HPP	hydro power plant
EPS	electric power system
ES	energy storage
EV	electric vehicle
G2V	grid-to-vehicle
HP	hydro power
LCT	low carbon technologies
MILP	mixed integer linear programming
NPP	nuclear power plants
OCGT	open cycle gas turbine
PS	pump storage
RES	renewable energy sources
TP	thermal power
TSC	total system cost
TSE	total system emissions
UC	unit commitment
V2G	vehicle-to-grid
WPP	wind power plant

and economic aspects. Similar to [9], the authors in [10] provides detail analyses of EV grid impacts and suggest DSO grid investment to support EV integration in order to better manage daily grid operations. Stochasticity of EV connection to the grid has been studied in [11] by optimization model updating if unexpected EV disconnections occur. Aggregating multiple EV units in a single market participant, so called virtual power plant, and coordinating their operation with different renewable and conventional generation units for future energy scheduling is proposed in [12]. Combined effects of high RES and EV integration is also analysed in [13] with different EV types and charging strategies emphasizing mutual benefits in scenarios with higher wind penetration. Improved utilization of wind and solar power, through flexible coordinated charging of EV has been discussed in [14] along with sensitivity analyses of different input parameters. Using EV as frequency controllers is proposed in [15] where it has been shown that EV can help utilize more variable RES by provision of frequency control. Automatic generation control (AGC) requirements are rapidly increasing with the uptake of RES, therefore, paper [16] proposes coordinated EV and battery storage frequency regulation supporting today's conventional frequency regulation providers. A novel s

tochastic-probabilistic energy and reserve market clearing scheme is proposed in [17], modelling plug-in vehicles (PEV) though a new market subject, a PEV aggregators. A bi-level optimization algorithm based on multiagent systems and dynamic game theory was developed in [18], modelling the oligopoly energy and reserve market. Authors in [19] use both EV and EH to improve efficiency of system and to allow higher integration of RES. Benefits of intelligent control of EV is researched in [20], where focus is put on analysing if EV can be used to substitute cross border capacities. Interesting review of EV technology's benefits and impediments can be found in [21–23]. As it can be seen from the above the topic of EV has been in focus in recent years, analysing its pros and cons from different perspectives, jointly concluding capability of EV to act as a provider of new flexibility will be one of key factors in determining the share of variable renewable sources in future power systems. However, it needs to be mentioned that none of the papers above elaborates how behaviour of conventional units changes taking into account both energy and reserve unit commitment plans. This paper provides a comprehensive analysis of EV as provider of spinning reserve services in future low carbon systems.

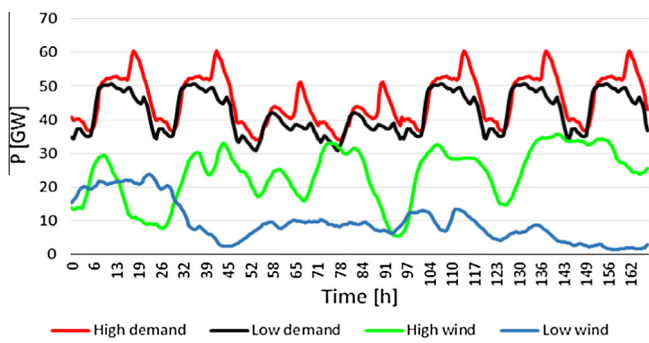

Fig. 1. Demand and wind profiles for a period of one week.

A number of models have been proposed for simulation of power system operation, in order to assess the power system operational flexibility. These mathematical models, called unit commitment schedules (UC), are most commonly based on Lagrangian relaxation [24] or more currently on mixed integer linear programming (MILP) [25], also modelling variability and uncertainty of both demand and supply by including stochasticity of wind, demand and market prices [26–28]. The model presented in this paper is based on a technique of clustering similar units, for example gas, coal and nuclear; this approach has been shown to significantly increase the computational speed of simulations [29–31] without losing on the accuracy of the results. Similar approach, simulating impact of EV integration on multiple interconnected systems can be found in [32,33]. The presented model is a continuation of work presented in [34] where the authors focus on how integration of controllable electric vehicle charging impacts the provision of secondary reserve services for various power systems with regards to the energy mix. In this paper, however, the focus is on three different analyses:

- *Flexibility contribution of LCT technologies (EV, ES and DR) through both energy and reserve services:* LCT technologies contribute to flexibility of future power systems characterized by high share of renewable sources. The results of the model clearly show how roles of traditional generation units in providing multiple services (energy and multiple reserve services) change with the integration of these technologies, specifically focusing on the role of EV.
- *Impact of traditional units decommission on future power system:* With respect to the above, the model demonstrates how decommission of traditional units impacts the flexibility of the future power system. In particular, this part focuses on redistribution between traditional and LCT sources for provision of energy and reserve services.

Table 1  
Input values and constraints of fossil fuel driven generation units.

Technology	$P_{min}$ (MW)	$E_{l1}$ (MW)	$E_{l2}$ (MW)	$P_{max}$ (MW)	$C_{nl}$ (\$/h)	$C_{in1}$ (\$/MW h)	$C_{in2}$ (\$/MW h)	$C_{in3}$ (\$/MW h)	$C_{st}$ (\$)	$C_{sh}$ (\$)	$T_{up}$ (h)
Nuclear	400	400	400	400	260.86	12.093	12.663	13.233	750	75	16
Coal	140	210	280	350	199.43	17.0805	17.3955	17.7105	450	45	8
CCGT	68.9	111.6	154.3	197	359.48	35.3535	35.6865	36.0195	300	30	5
OCGT	4	9.3	14.7	20	176.92	56.937	57.1545	57.3735	46	4.6	0.5
	$T_{dn}$ (h)	$V_{up}$ (MW/h)	$V_{dn}$ (MW/h)	$P_0$ (MW)	$N_0$	$RHO_{up}$	$RHO_{dn}$	$F_{iup}$ (MW)	$F_{idn}$ (MW)	Emiss. (kgCO <sub>2</sub> /MW h)	Start emiss. rate (kgCO <sub>2</sub> )
Nuclear	10	50.5	100	12.000	30	0.5	0.5	40	40	0	0
Coal	5	70	120	10.500	30	0.4	0.4	35	35	925	25.000
CCGT	4	55	99	0	0	0.6	0.6	19.7	19.7	394	8000
OCGT	0.5	30.5	70	0	0	0.7	0.7	2	2	600	3000

Table 2  
Input values and constraints of EV.

Input parameter	Personal vehicle
$P_{min}$ (kW)	0.2
$P_{max}$ (kW)	2
$S_{min}$ (kW h)	4
$S_{max}$ (kW h)	20
$S_{minc}$ (kW h)	20
$\eta_c, \eta_d$	0.95
$P_{jmax}$ (kW)	50
Range (km)	Short 20 Medium 40 Long 80
Consumed energy per trip (kW h)	Short 4 Medium 8 Long 16
Percentage of EVs type and range in total number of EVs	Short 82% Medium 10% Long 8%

- *Comparison of LCT technologies and different wind policies as flexibility providers:* The last aspect of the paper focuses on single week power system operation with respect to the above decommission scenarios, analysing different wind power plant (WPP) policies. In particular it focuses on the system operation in cases of: (a) penalized wind curtailment and (b) using WPP as secondary reserve providers.

The above issues are, up to a certain point, a research topic in a number of papers, see for example [35], however with several very important differences. In [36,37] the authors define the flexibility through minimum stable generation (MSG) of the power system as metric critical for integration of large scale wind. In [36] a metric is proposed for defining the amount of wind that can be integrated without curtailment, however it focuses only on the value of MSG, neglecting the ramping and other relevant technical constraints such as minimum up and down times of units being scheduled. In addition, neither of the papers elaborates on the mathematical models used to study the flexibility or elaborates on multiple services assigned/scheduled to particular units. A number of papers [38–40] propose pathways for achieving high RES integration, however they are not based on mathematical modelling nor do they focus on provision of flexibility services from specific technologies. On the other hand, [41,42] model provision of multiple services but do not focus on flexibility and integration of RES rather on reliability aspects of power system operation and reduction of CO<sub>2</sub> emissions. In [43,44] the authors propose a rolling UC for planning of future power systems. The focus of the work is on technical and economic constraints of the

system for future wind scenarios. With respect to that they propose a flexibility metric for planning high RES system energy mix, taking into account MSG and ramping constraints of existing and new units. Similar idea can be found in [45] where the author analyses impact of relaxing UC constraints on the accuracy of the results in UC scheduling. Neither of these two papers considers EV nor their contribution to the flexibility services in integration of RES. Finally, in [46] the authors evaluate impact of electric vehicles on future energy portfolio. The impact of coordinated charging of electric vehicles is assessed for multiple countries where EV are controlled in order to increase the flexibility by providing energy arbitrage. None of the multiple reserve services are specifically considered.

The MILP model of UC presented in this paper is unified in terms that it allows the above mentioned analyses for different energy mix power systems, ranging from low flexible nuclear dominated power system, such as the one in UK, to highly flexible hydro dominated power system, similar to the one in Croatia. It models multiple reserve services, primary, secondary and tertiary, as in [47,48], and focuses on the impact integration of EV will have on the role of existing units in future high RES scenarios.

The paper is organized as follows: In Section 2 detailed explanation of the MILP model of multiple service UC is given. Modelling of EV is based on mobility patterns and considers different vehicles sizes and batteries on board of the vehicles. Although EV can be

scheduled for provision of multiple services, in Section 3 an analysis of spinning reserves is given through different scenarios of wind and EV penetration. Section 4 further analyses the flexibility of the system in the presence of EV and wind, analysing how different decommission stages impact system’s flexibility. Section 5 observes system operation through one week and changes due to decommission for different wind turbines policies (penalizing wind curtailment and using wind as reserve provider). Finally, Section 6 provides conclusions and guidelines for future work.

### 2. Multiple service unit commitment (MSUC) modelling

The presented model is similar to the one presented by the authors in [34], however for easier understanding it will be again elaborated in the following section.

The objective function driving the power system operation is minimization of the operational costs from all units providing energy and reserve services to the system, as shown in (1). The objective function models all operational costs of thermal (start-up, shut-down, fuel, O&M, greenhouse gas emissions) and hydro (O&M) units, linearizing fuel consumption curve of thermal power plants as in [49,50].

$$\text{minimize COST} = \sum_{t=1}^{N_t} \left[ \sum_{i=1}^{N_{i\_TP}} (c_{t,i}^{TP}) + \sum_{i=1}^{N_{i\_HP}} (c_{t,i}^{HP}) \right] \tag{1}$$

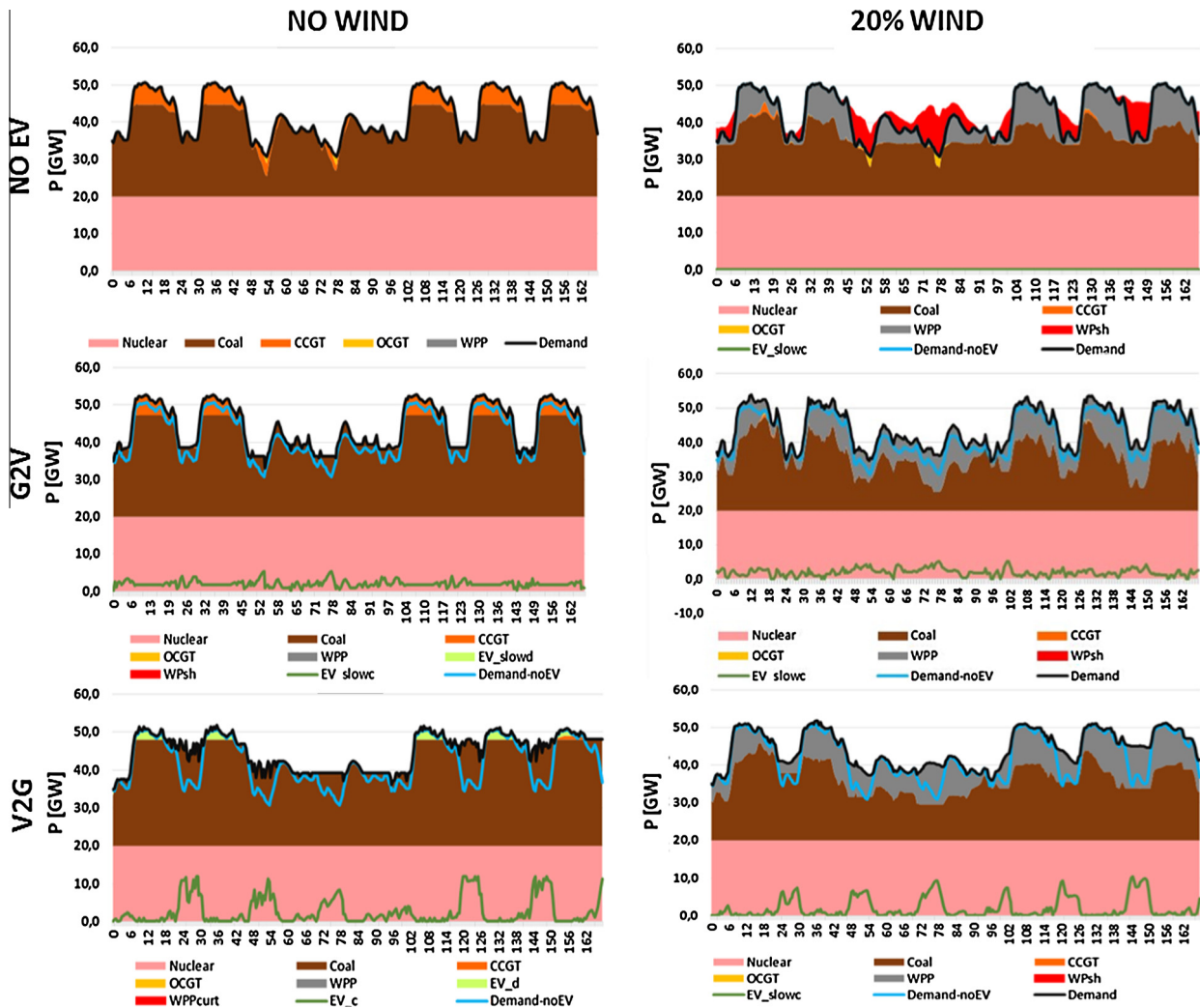

Fig. 2. Energy service scheduling in different wind and EV scenarios.



Electricity equilibrium has to be maintained in all simulation periods, meaning that the total generation from all units in the system has to be equal to the total demand as shown in Eq. (2). Left side of the equation summarizes the production of all generation units considered; conventional units (since the model is unified, these can be thermal –  $p_{t,i}^{g\_TP}$ , hydro –  $p_{t,i}^{g\_HP}$ , generation from hydro pump storage unit –  $p_{t,i}^{g\_PS}$ ), RESs (wind –  $p_{t,i}^{g\_WP}$ ), storage (in this paper pump storage pumping –  $p_{t,i}^{p\_PS}$ ; is considered as storage technology) with added EVs discharging ( $p_{t,i}^{d\_EV}$ ), charging ( $p_{t,i}^{c\_EV}$ ) and fast charging ( $p_{t,i}^{f\_EV}$ ). The right side of the equation models electric demand ( $P^d$ ). For the case of UK power system, taken as an example of low flexible power system driven by thermal power plants, demand and wind profiles are shown in Fig. 1 [51]. Additional data about UK power system used can be found in [52].

$$\sum_{i=1}^{Ni\_TP} (p_{t,i}^{g\_TP}) + \sum_{i=1}^{Ni\_HP} (p_{t,i}^{g\_HP}) + \sum_{i=1}^{Ni\_PS} (p_{t,i}^{g\_PS} - p_{t,i}^{p\_PS}) + p_{t,i}^{g\_WP} - \sum_{i=1}^{Ni\_EV} (p_{t,i}^{d\_EV} - p_{t,i}^{c\_EV} - p_{t,i}^{f\_EV}) = P_t^d \quad (2)$$

The reserve requirements of the system are modelled by (3)–(7). Multiple reserve services are modelled; primary up reserve ( $f_{up}$ ), primary down reserve ( $f_{dn}$ ), secondary up reserve ( $r_{up}$ ), secondary reserve down ( $r_{dn}$ ), tertiary up reserve ( $q_{up}$ ). The primary reserve can be provided by all units, as shown in (3) and (4),

however technical limitations of the power plants usually mean that power plants participate with about 10% in the primary frequency provision. Modelling primary frequency response is based on the model in [53]. Primary reserve value that needs to be reserved for the size of the system simulated, both up and down, is set to 1.9 GW as in [51,53].

Secondary reserve can again be provided by all units in the system, conventional and EV. Although EV could also participate in tertiary reserve, due to their capability of reacting to fast system changes, they are considered only for spinning reserve service provision (primary and secondary reserve).

$$\sum_{i=1}^{Ni\_TP} f_{t,i}^{up\_TP} + \sum_{i=1}^{Ni\_HP} f_{t,i}^{up\_HP} + \sum_{i=1}^{Ni\_PS} f_{t,i}^{up\_PS} + \sum_{i=1}^{Ni\_EV} f_{t,i}^{up\_EV} \geq F_t^{up} \quad (3)$$

$$\sum_{i=1}^{Ni\_TP} f_{t,i}^{dn\_TP} + \sum_{i=1}^{Ni\_HP} f_{t,i}^{dn\_HP} + \sum_{i=1}^{Ni\_PS} f_{t,i}^{dn\_PS} + \sum_{i=1}^{Ni\_EV} f_{t,i}^{dn\_EV} \geq F_t^{dn} \quad (4)$$

$$\sum_{i=1}^{Ni\_TP} r_{t,i}^{up\_TP} + \sum_{i=1}^{Ni\_HP} r_{t,i}^{up\_HP} + \sum_{i=1}^{Ni\_PS} r_{t,i}^{up\_PS} + \sum_{i=1}^{Ni\_EV} r_{t,i}^{up\_EV} \geq R_t^{up} \quad (5)$$

$$\sum_{i=1}^{Ni\_TP} r_{t,i}^{dn\_TP} + \sum_{i=1}^{Ni\_HP} r_{t,i}^{dn\_HP} + \sum_{i=1}^{Ni\_PS} r_{t,i}^{dn\_PS} + \sum_{i=1}^{Ni\_EV} r_{t,i}^{dn\_EV} \geq R_t^{dn} \quad (6)$$

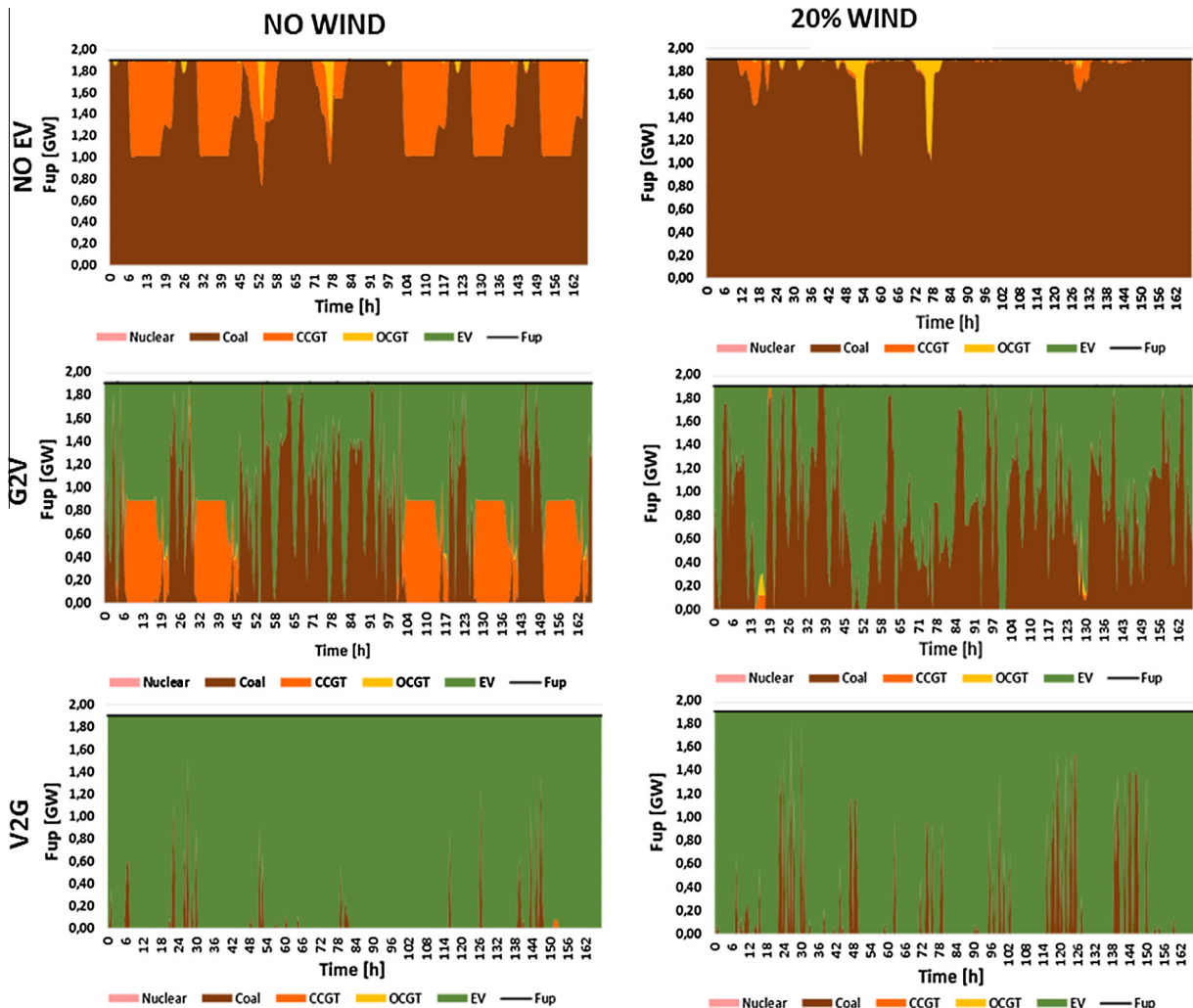

Fig. 3. Results of scheduling primary frequency reserve service in different wind and EV scenarios.

$$\sum_{i=1}^{N_{i\_TP}} q_{t,i}^{up\_TP} \geq Q_t^{up} \quad (7)$$

Secondary and tertiary reserve values are defined as time vectors depending on the electrical demand (taking into account variability of demand through standard deviations of load forecast  $\sigma^d$ ), wind power production (taking into account uncertainty and variability of wind generation modelled as standard deviation of wind forecast  $\sigma^{(0.5h)\_WP}$  and  $\sigma^{(4h)\_WP}$ ) and EV's as well as the outage of the largest generating unit  $P_t^{gmax}$ . Uncontrollable charging of EV's results in increase of the secondary and tertiary reserve requirements. This is modelled as a fixed value, describing uncertain nature of EV arrival and battery SOC through parameters  $R_t^{EV\_0.5h}$  and  $R_t^{EV\_4h}$ . In this paper only controlled (G2V and V2G) charging is observed so parameters  $R_t^{EV\_0.5h}$  and  $R_t^{EV\_4h}$  are equal to zero. It should be noticed that both upward and downward reserve have been modelled. Modelling of secondary and tertiary reserve is similar to that in [44] and described by (8)–(12):

$$R_t^{EV\_0.5h} = \sum_{i=1}^{N_{i\_EV}} \left( 3.5 * \sigma_t^{sl(0.5h)\_EV} * P_i^{max\_EV} * \sum_{\tau=t}^{t(-C_i^{UCH\_EV}+1)} N_{\tau,i}^{arr\_EV} \right) \quad (8)$$

$$R_t^{EV\_4h} = \sum_{i=1}^{N_{i\_EV}} \left( 3.5 * \sigma_t^{sl(4h)\_EV} * P_i^{max\_EV} * \sum_{\tau=t}^{t(-C_i^{UCH\_EV}+1)} N_{\tau,i}^{arr\_EV} \right) \quad (9)$$

$$R_t^{up} = \sqrt{(3 * \sigma^d * P_t^d)^2 + (3.5 * \sigma_t^{(0.5h)\_WP} * P_t^{WP})^2 + (R_t^{EV\_0.5h})^2} + P_t^{gmax} \quad (10)$$

$$R_t^{dn} = \sqrt{(3 * \sigma^d * P_t^d)^2 + (3.5 * \sigma_t^{(0.5h)\_WP} * P_t^{WP})^2 + (R_t^{EV\_0.5h})^2} \quad (11)$$

$$Q_t^{up} = \sqrt{(3 * \sigma^d * P_t^d)^2 + (3.5 * \sigma_t^{(4h)\_WP} * P_t^{WP})^2 + (R_t^{EV\_4h})^2} + P_t^{gmax} \quad (12)$$

As mentioned in the introduction, similar approach to modelling can be applied to both energy storage systems and demand side technologies, such as electrified heating (EH). In general, both EV and EH can be modelled as variable capacity energy storage providing both energy arbitrage and reserve provision. While EV energy storage capacity depends on driving behaviour and EV charging mode, variable capacity energy storage of EH depends on heat demand of the consumers, capacity and size of heat storages (if it exists) and the comfort required by the final consumer. In this context, energy consumed by EV for driving between two adjacent periods is analogue to energy consumed by EH for heating (with the difference of efficiency factors, which are of course different). Although the main idea can appear the same, there are several important differences defining the availability and the amount of different system services. However, the logic used in the above

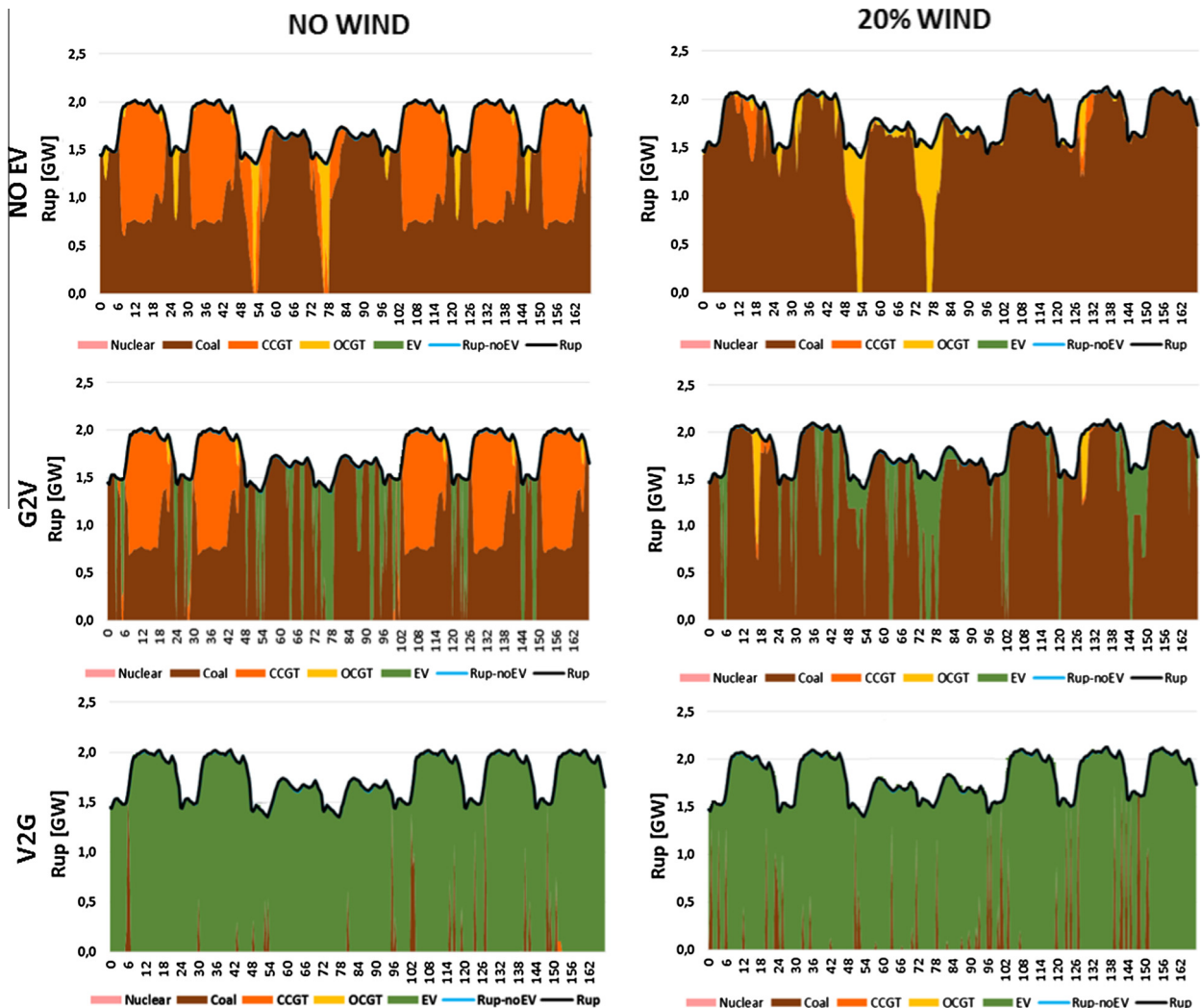

Fig. 4. Results of scheduling secondary frequency reserve service in different wind and EV scenarios.

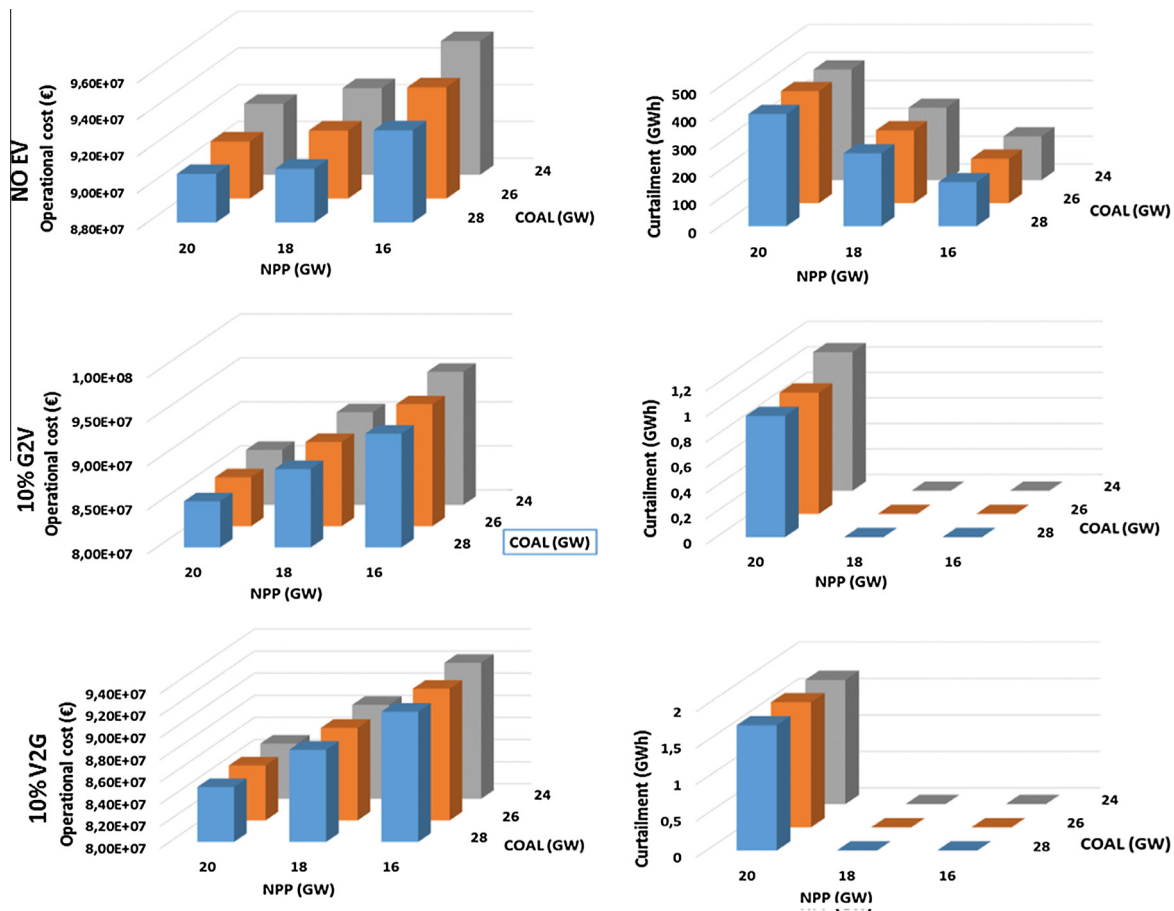

Fig. 5. Power plant decommission analysis in power system with 20% wind energy.

EV model can be applied to the electrified heating flexibility provision analyses by adjusting specific constraints and input parameters.

Modelling technical limitation of fossil fuel based power plants is taken from recent publications [54–56] where thermal units are subjected to the following constraints: power generation constraints (piece-wise linear cost curve), minimum up and down times, ramping constraints, reserve provision constraints (primary, secondary and tertiary), greenhouse gas emissions (included as additional cost in objective function). In addition, hydro power plants are modelled similar to the models in [57,58]. Details on input parameters of power plants is given in Table 1.

Mathematical models of all possible EV operational regimes are shown in [34] where 6 different concepts are presented, depending on controllability of EV and number of services these units provide. In this paper only a description of selected operating regimes used in the simulations is provided for understanding specific charging/discharging concept. In this paper only controllable charging is considered where EV provide multiple services (energy and reserve). This controllable charging can be G2V (vehicles are “only” controllably charged) or V2G (vehicles can be controllably discharged, injecting electricity back to the system and providing additional value). Once again, only 2 out of 6 EV regimes are selected for the purpose of simulations in the following Sections:

- Controlled Grid-to-Vehicle charging with possibility to provide reserve, both upward (additional electricity for charging) and downward reserve (not charging EV) – G2V.

- Controlled Vehicle-to-Grid charging with possibility to provide reserve, both upward (additional electricity for charging) and downward reserve (discharging EV) – V2G.

Input values and constraints for EV modelling are given in Table 2.

Wind power plants as variable renewable source are modelled with following equation, where right side corresponds to maximal wind power at particular moment and left side is composed of actual wind power produced and wind power curtailed.

$$p_t^{g\_WP} + p_t^{curr\_WP} = P_t^{-WP} \quad (13)$$

### 3. Weekly operational analyses

To define how the role of specific unit changes in systems with high wind penetration, weekly analyses of the system operation are run for several relevant scenarios. The focus is put on provision of energy as well as primary and secondary reserve, including participation of EVs in all these services. Two scenarios are further analysed for 3 different EV cases, one with no wind integrated in the system and one where installed wind power is 20% of total power demand:

- No electric vehicles integrated.
- G2V scenario: Electric vehicles can only be charged, meaning they act as controllable loads providing both energy and upward and downward reserve services.

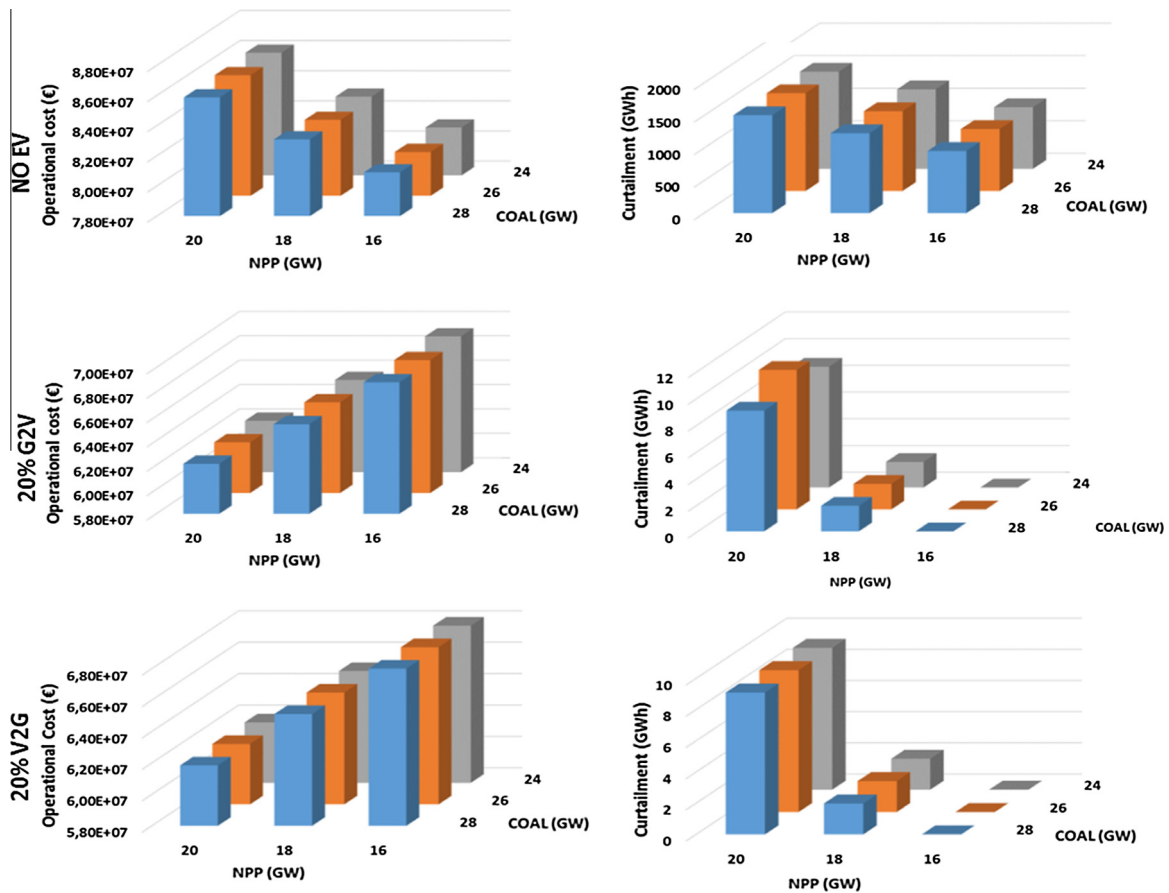

Fig. 6. Power plant decommission analysis in power system with 40% wind energy.

- V2G scenario: Electric vehicles can be both controllably charged and discharged providing both energy and upward and downward reserve services.

Fig. 2 shows the results of power system dispatch for a period of one week, in particular which units provide energy service over 6 analysed cases. The layout of the figure enables comparing both the impact of wind integration and the impact of EV flexibility on provision of multiple services.

Looking at the first two scenarios, where EVs are not included in provision of flexibility services (first “row” of Fig. 2), it can be seen that the current system is not flexible enough and, to maintain the security of supply, wind is curtailed. Alongside wind curtailment, changes in coal and gas thermal plants behaviour can be noticed when wind takes part in providing energy. The most expensive gas turbines are shut down and their former production is now substituted by wind. Wind integration reduces operating periods of gas power plants to only two cases: when demand is high and wind is low (insufficient generation requires starting up of CCGT units) and when demand is low and wind production is high. Already in G2V mode wind curtailment is eliminated (as can be seen in second row of Fig. 2). In G2V mode EV charging is uniformly distributed (both in case with wind and without wind) since EVs are used for reserve provision. On the other hand, in V2G mode and no wind, EVs take on the role of fast responding units covering daily peak demand.

Fig. 3 shows the provision of primary frequency response (PFR) for all of the above 6 scenarios. It should be noted that integration of wind does not directly affect the amount of primary reserve required, however due to different dispatching of the conventional units which provide secondary and tertiary reserve service, provi-

sion of PFR is assigned to the different units. Since EV have, due to their technical characteristics, the capability to respond to fast changes, the role of providing PFR switches from classical thermal units (coal and CCGT) to electric vehicles with the integration of EV and wind, in particular in cases where they can be controllably charged and discharged (V2G case). This mitigation of PFR service means more efficient thermal units operation and reduction of expensive units’ start-ups (e.g. CCGT, see Table 2), resulting in lower system operational cost.

Provision of secondary frequency reserve service (SFR) from specific units, is shown in Fig. 4, for all the above described scenarios of wind and flexible EV integration. Similar to PFR, EV take over the role in providing SFR from expensive CCGT units and, in case where they can provide additional flexibility by discharging, coal units.

To summarize; by integrating wind, gas driven units are initially substituted by that of coal. Gas units are taking the role of standing reserve, since they are the most expensive ones, and, since primary and secondary reserve needs to be provided by spinning units, coal units take on the role of providing PFR and SFR. Furthermore, in case when EVs have the capability to both charge and discharge (V2G regime) they cover over 95% of PFR and SFR needs in the system while conventional units solely provide energy and tertiary reserve service.

#### 4. Impact of different units in future flexible power systems

Integration of renewable energy sources are often put in the context of replacing conventional units such as high carbon intensity coal and low flexible nuclear power plants. Several strategies



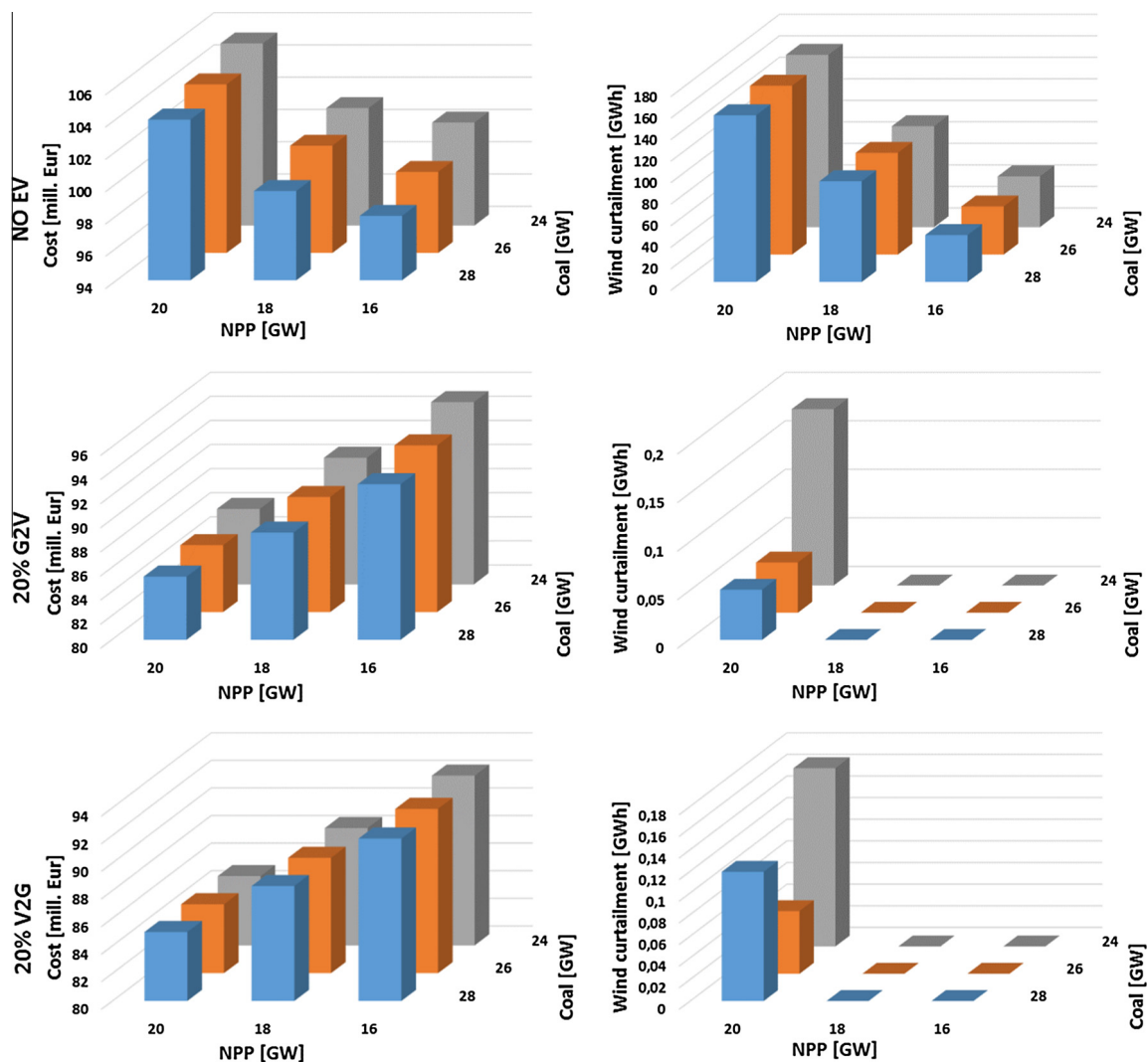

Fig. 7. Power plant decommission analysis in power system with 20% wind energy and curtailment penalty.

even suggest that these units should be decommissioned and that RES and LCT will take on their role in the power system. However, very little research has been done on how such actions reflect on total system operational cost and system's flexibility. In this paper insufficient flexibility is expressed as the curtailed wind energy. In the following Section a detailed analysis is provided answering these questions.

Governments worldwide made a decision to decommission or to rely less on nuclear energy, particularly after the Fukushima incident in 2011. In addition, national greenhouse gas goals suggest shutting down coal power plants. The main idea of this Section is to analyse how decommissioning of conventional low flexible power plants, in case coal and nuclear, reflects on system operational cost and wind curtailment. It has been shown in Fig. 2 that nuclear power plants serve as base load units and are not scheduled for provision of reserve services nor for load following. Although NPP have the flexibility to ramp and respond to variability of the system, they are, for security reasons, operated either on their maximum power, at their minimum stable generation point (MSG) or they are offline. It should be noted that once NPP is shut down it takes between 24 and 48 hours to start it back again; each NPP start-up is expensive and these actions are thus avoided if possible. Although a bit more flexible, coal power plants,

once shut down, cannot be put online for the next 4–6 h (depending on the level of shut down; hot, warm or cold).

Fig. 5 shows the results and the effects of decommissioning coal and NPP for the same scenarios as in the previous Section. A general conclusion can be made that, by decommissioning either coal or NPP, curtailment of wind is reduced and total systems operational cost increases. Although the last statement might seem a bit contradictory, decommissioning of low flexible units in fact reflects in changing the role of conventional units. In fact, with the decommissioning of inflexible units (coal and NPP) highly flexible, but expensive, gas units (CCGT and OCGT) take on the role of energy provision and due to their higher flexibility they are capable to follow fast wind power generation alternations. Since wind curtailment is decreased (due to the increase in systems flexibility) and more “free” wind power is supplied to the customers, the total systems operational cost should decrease. However, the higher cost result should not be observed only through the shift of energy being provided from wind and gas instead of coal and NPP, but also through different scheduling of spinning reserve. As the number of NPP and coal units decreases this consequently results in less available coal base power plants for providing reserve services. This “void” is in particularly noticeable in reserve up provision, where gas units take the role of reserve provider.

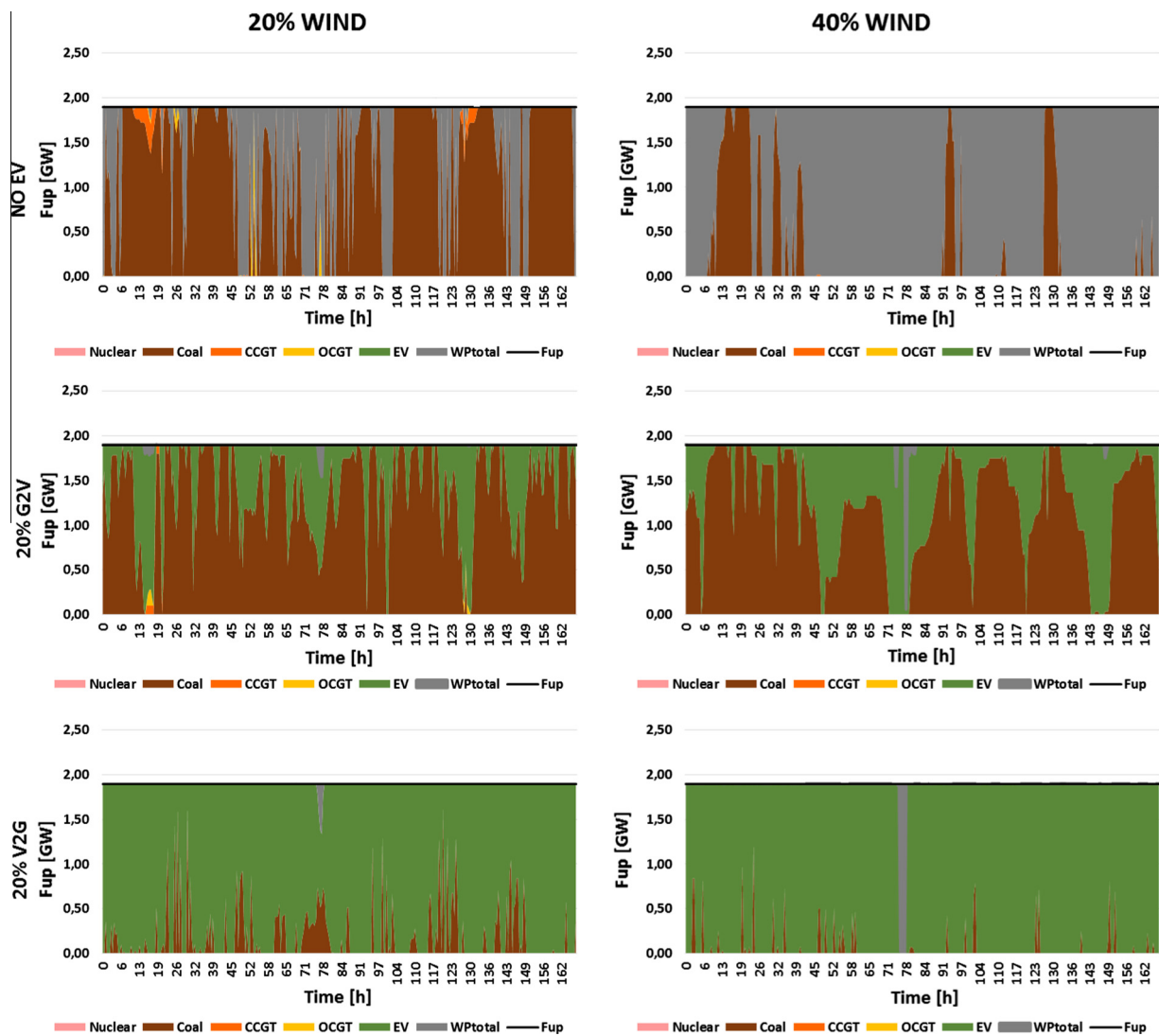

Fig. 8. Results of scheduling primary frequency reserve service in different wind and EV scenarios (with wind turbines reserve provision).

As in previous scenarios, integration of controllable EV charging results in significant wind curtailment reduction (300 times lower than without EV). The most significant change in scenarios with flexibility provided from G2V is in reserve down provision, which is now completely provided by controllable EV for all analysed decommission scenarios. Additional provision of flexibility by deploying V2G capability is manifested through lower total operational cost than in previous scenarios; the role of other units remain the same.

The same analyses are conducted for an even larger penetration of wind, doubling the share of wind power to 40%, and the results are shown in Fig. 6.

By decommissioning low flexible NPP and coal the curtailed wind energy is significantly reduced, which directly impacts the operational cost. Gas turbines are, similarly as in previous Section, used for load following and peak covering (mainly CCGT units) as well as during periods when reserve cannot be entirely provided by operating coal power plants (in those cases fast responding OCGT units start up).

Integration of controllable EV additionally reduces wind curtailment by a margin of 1000. In addition, similar as in 20% wind scenario, operational cost increases when non flexible units are decommissioned. High wind penetration changes operational regime of coal power plants by increasing their number of start-

up times and forcing them to more frequently ramp in both directions, which leads to lower efficiency of these units.

A general conclusion can be made that by decommissioning NPP and coal units the system flexibility increases, completely eliminating wind curtailment. However, and this in particular is valid for NPP, decommissioning the low cost base load units means that more expensive gas driven units take on the role of providing both energy and reserve services, cycling and increasing the number of their start-ups. This in turn results in total operational cost increase.

## 5. Wind power plants as flexibility providers

In previous Sections wind curtailment is regarded as an indicator of insufficiently flexible system and it has not been penalized, similar to the model in [35]. The literature proposes two approaches: penalizing wind curtailment and not penalizing, each with its pros and cons. On one hand high cost assigned to wind energy not utilized creates large operational cost spikes and indicates inflexibility, however it sets the operating points of power plants to unlikely states (in reality, wind generation would be curtailed if this favoured the security and economy of the system operation). On the other hand, avoiding to penalize wind not used

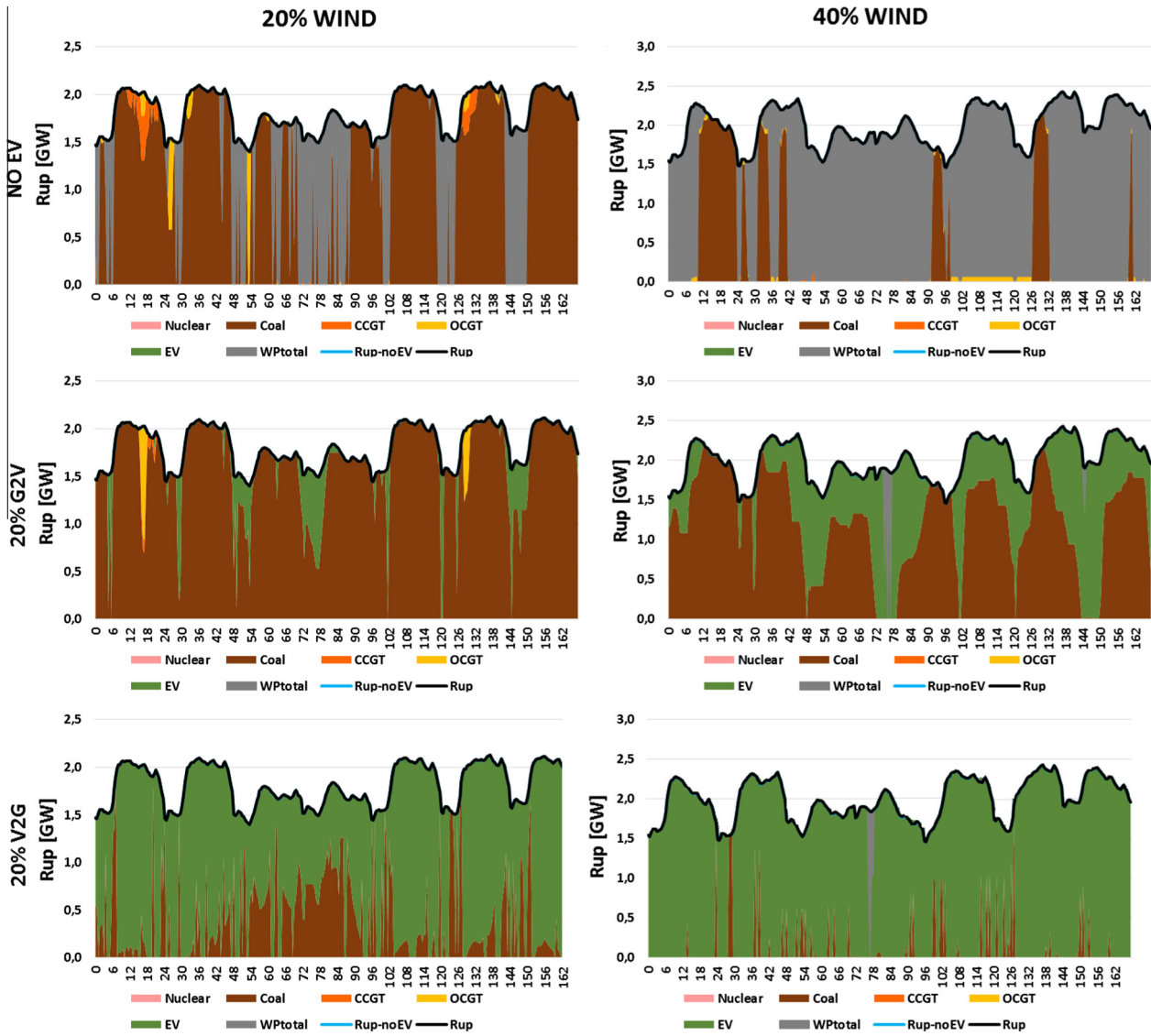

Fig. 9. Results of scheduling secondary frequency reserve service in different wind and EV scenarios (with wind turbines reserve provision).

might result in overestimating the share of wind being curtailed in low flexible systems as the one analysed in this paper.

A lot of research has been done over past few years in order to reduce or even eradicate wind curtailment [59–63]. Following this research the focus of the Section will be on two most likely roles wind power plants will have in the future: (i) wind curtailment as an indicator of inflexibility and penalized as in [64] and (ii) wind used for upward reserve provision as in [65]. For the first approach a new variable is added to the objective function,  $c_t^{\text{curt\_WP}}$ , which denotes curtailed wind energy at every moment; this energy is multiplied with penalty factor ( $\text{PF}^{\text{curt\_WP}} = 46.7 \text{ €/MW h}$ ). New objective function, including new curtailment cost function, is represented with Eqs. (14) and (15), respectively.

$$\text{minimize COST} = \sum_{t=1}^{N_t} \left[ \sum_{i=1}^{N_{i\_TP}} (c_{t,i}^{\text{TP}}) + \sum_{i=1}^{N_{i\_HP}} (c_{t,i}^{\text{HP}}) + c_t^{\text{curt\_WP}} \right] \quad (14)$$

$$c_t^{\text{curt\_WP}} = p_t^{\text{curt\_WP}} * \Delta t * \text{PF}^{\text{curt\_WP}} \quad (15)$$

As mentioned above, the second approach considers the case when wind power plants are providers of flexibility, participating in primary and secondary up reserve. In this sense, Eqs. (3), (4)

and (13) are replaced with (16), (17) and (18) respectively, introducing new variables  $f_t^{\text{up\_WP}}$  (upward primary frequency response provided by wind power plants) and  $r_t^{\text{up\_WP}}$  (upward secondary reserve provided by wind power plants).

$$\sum_{i=1}^{N_{i\_TP}} f_{t,i}^{\text{up\_TP}} + \sum_{i=1}^{N_{i\_HP}} f_{t,i}^{\text{up\_HP}} + \sum_{i=1}^{N_{i\_PS}} f_{t,i}^{\text{up\_PS}} + \sum_{i=1}^{N_{i\_EV}} f_{t,i}^{\text{up\_EV}} + f_t^{\text{up\_WP}} \geq F_t^{\text{up}} \quad (16)$$

$$\sum_{i=1}^{N_{i\_TP}} r_{t,i}^{\text{up\_TP}} + \sum_{i=1}^{N_{i\_HP}} r_{t,i}^{\text{up\_HP}} + \sum_{i=1}^{N_{i\_PS}} r_{t,i}^{\text{up\_PS}} + \sum_{i=1}^{N_{i\_EV}} r_{t,i}^{\text{up\_EV}} + r_t^{\text{up\_WP}} \geq R_t^{\text{up}} \quad (17)$$

$$p_t^{\text{g\_WP}} + p_t^{\text{curt\_WP}} + f_t^{\text{up\_WP}} + r_t^{\text{up\_WP}} = p_t^{\text{WP}} \quad (18)$$

The goal of this study is to understand the decommissioning effect with different wind policies for both cases with and without EV. Fig. 7 shows how introducing wind curtailment penalty factor reflects on previously analysed scenarios of decommissioning of NPP and coal power plants. In the initial scenario with no EV, shown in first row of Fig. 7, by reducing the installed power of low flexible units - total system operational cost reduces, unlike the previous analyses shown in Fig. 5. With the introduction of wind power curtailment penalty factor (PF) the amount of wind

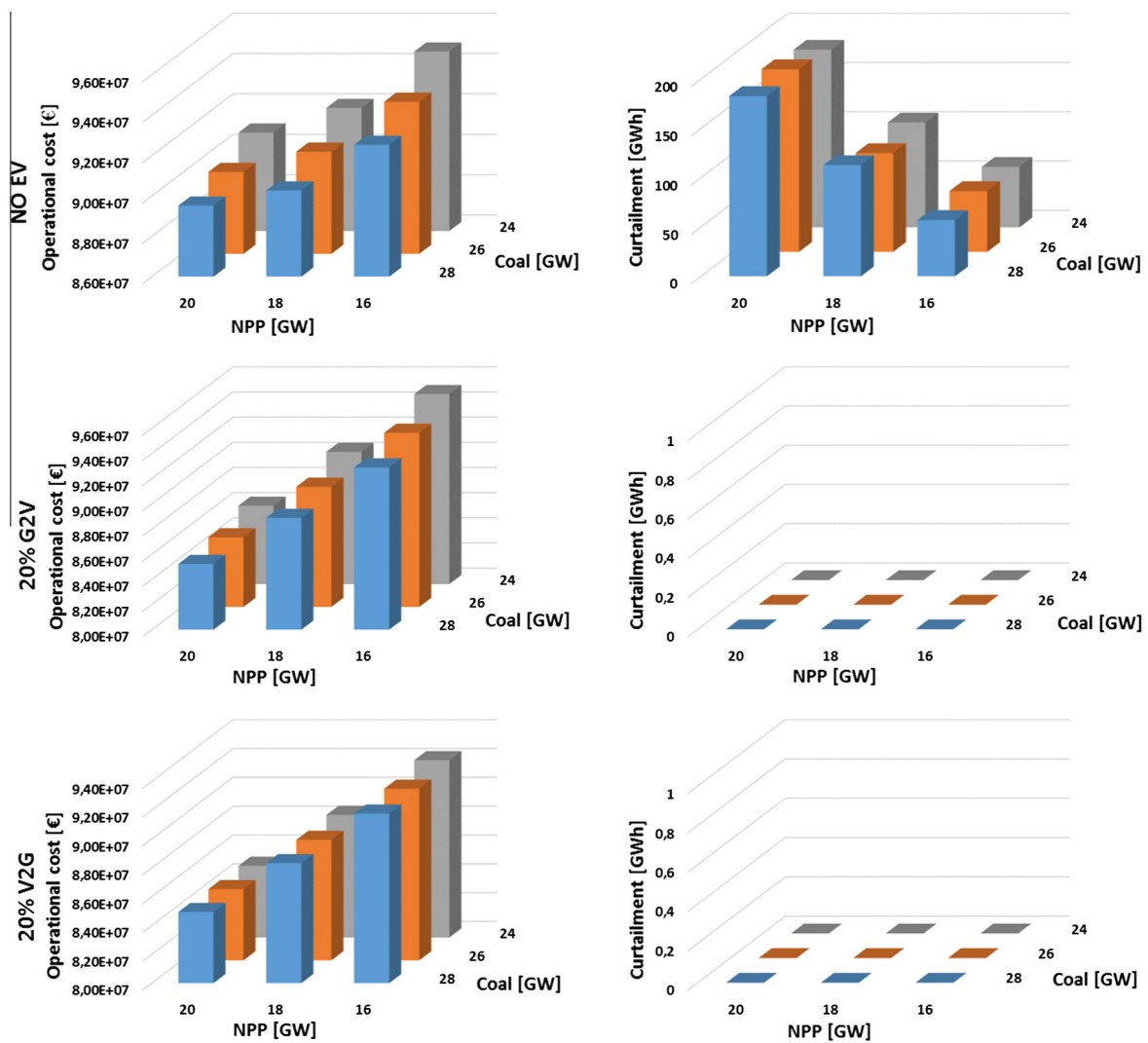

Fig. 10. Power plant decommission analysis in power system with 20% wind energy and possibility of wind upward reserve provision – graphical results.

energy curtailed is reduced by more than 50%. However, at the same time total system operational cost increases by more than 12% compared to the case shown in Fig. 5. This suggests that monetary gains due to lower curtailed wind are higher than cost increase due to the usage of more expensive conventional units (in this case of gas units). In the remaining cases, with EV integrated, no noticeable changes in power system operation are visible – introduction of PF does not impact cost and curtailment trends in power systems with high wind and EV penetration. The results for the systems with 40% wind share are similar to the scenarios of 20% wind share or no PF introduced.

Although wind curtailment can, to a certain extent, be considered as an “emergency flexibility” service provision, an interesting concept is presented by authors in [65], where they explain in details how upward reserve provision from wind turbines can decrease both wind curtailment and total system cost. As wind is used for up reserve provision in high wind periods it decreases both required reserve and reserve provided by conventional power plants thus allowing more efficient operation of those conventional units. Conventional units run closer to their optimal points and their intra-day cycling is reduced.

In order to better elaborate on the changes in system scheduling with wind turbines as reserve providers, weekly analyses, similar

to those shown in Figs. 2–4 are again shown here in Fig. 8 (for scheduling provision of primary reserve) and Fig. 9 (for scheduling of secondary reserve). Again, three different EV charging regimes are considered, NO EV, G2V and V2G, for wind penetration levels 20% (left column of Figs. 8 and 9) and 40% (right column of Figs. 8 and 9). New variable  $WP_{total}$  is referring to wind reserve provision. The energy service diagram is omitted because of the succinctness of the paper.

In the initial case, with no EV, both primary and secondary reserve are scheduled differently when reserve can be provided by wind turbines. In the reference case whenever power system (due to its technical constraints) could not use wind for power generation there was significant amount of wind curtailed. Here, surplus of the available wind power is used for primary and secondary reserve provision. In general, it means that expensive gas turbines have significantly fewer start up times in order to provide energy of reserve services. Still, during some critical periods (for example from 13 to 16 h) when there is not enough wind, gas turbines are started up from cold state to provide needed energy and reserve services. In case where wind energy can meet 40% of total demand, these “critical periods” are eliminated; the need for gas turbines, in particularly expensive start-up of gas units, is eliminated since more wind entails more curtailment which leaves more space for



wind energy provision and, more importantly, reserve provision. More wind reserve provision also means relaxed and more efficient operation of coal units.

Introduction of EV by G2V mode brings new changes to the reserve scheduling problem. With 20% of wind penetration almost all wind reserve provision is shifted to EV; EV take over reserve provision enabling higher wind utilization for provision of energy. In general, periods when reserve is not provided by conventional units can be regarded as systems inflexible points, when any kind of new flexibility provider is welcome just to hold of starting up or shutting down inflexible units from the cold state. In V2G mode EV provide both primary and secondary reserve in 20% and 40% wind penetration scenarios.

Similar to previous analyses, Fig. 10 offers a detailed perspective on how different stages of decommissioning NPP and coal impacts total system cost and wind curtailment, this time considering wind power plants as additional flexibility provider (providing primary and secondary upward reserve). Initial scenario, not considering EV, shows decrease in both total system operational cost and wind curtailed (when compared to the reference case in Fig. 5).

Introduction of EV brings new flexibility to power system mitigating provision of flexibility services from wind turbines to EV. Total system cost increases similar as in the reference case, while flexible EVs entirely eliminate wind curtailment.

To conclude the Section the following conclusions can be made:

- (i) Case 1: Wind curtailment penalized:
  - Wind curtailment penalty factor increases total system cost and sets operating points of other power plants to non-realistic states.
  - Decommission of low flexible units in such system, without EV, decreases total system cost. While scheduling more expensive gas units to take on the role of nuclear and coal results in operating cost increase, this is still less than decrease due to lower wind energy curtailed. However, a similar conclusion is valid as for the above point – due to “forcing” of wind usage the remaining units operating points are not reflecting the realistic state resulting higher ramping and more cycling of the units.
  - When EV are included (both G2V and V2G mode) PF does not affect power system operation since EV provide enough flexibility and there is no wind curtailment.
- (ii) Case 2: Wind turbines provide upward primary and secondary reserve:
  - In scenarios not considering EV, wind is used for primary and secondary reserve provision instead of gas turbines. The higher wind penetration is, the lower system requirement for gas turbine services is.
  - Usage of wind for reserve provision decreases total system cost and wind curtailment.
  - Low flexible unit decommissioning in such system (without EV) increases total system cost and decreases wind curtailment in the same manner as in reference case (Section 4).
  - When EV are included (both G2V and V2G mode) wind turbines are not preferred as reserve providers any more since EV introduce enough flexibility.
  - When EV are included (both G2V and V2G mode) while decommissioning total system cost increases similar to the reference case.

## 6. Conclusion

The paper presents a mathematical model of power system operation capable of analysing systems flexibility and the impact of integrating renewable energy and flexible low carbon technolo-

gies, in this case EV. The model captures all technical characteristics and constraints of power system components, modelling different types of EV and different aspects of controllable charging/discharging where EV can provide multiple system services. In low flexible power systems, and usually highly carbon intensive, integration of controllable EVs has a positive effect on all aspects of power system operation, ranging from reduced operational cost, lower curtailed wind energy to lower carbon emissions due to more efficient operation of conventional units. Their capability to respond to fast changes following systems variability and uncertainty means they take over the role that is traditionally assigned to coal and gas power plants in providing of PFR and SFR, resulting in lower operational cost and CO<sub>2</sub> emissions. Another aspect, reflecting more planning than operation aspect of future low carbon systems, is addressed in the paper by showing the effect of decommissioning coal and nuclear power plants in systems with high share of wind power plants and flexible EV. The results clearly show that, although the system in general becomes more flexible by lowering systems MSG and increasing its ramping capability, the positive effects of reduced wind curtailment is followed by increase in systems operational cost. This occurs due to increased utilization of gas units, their cycling behaviour and high start-up costs. Third aspect involves different wind policies: penalization of wind curtailment and wind upward reserve provision. If no EV are present in the system as a source of flexibility, penalizing wind curtailment has a negative effect on power system operational cost, increasing it by 12%, even though curtailment is decreased by 50%. However, under this policy, decommission of low flexible units affects the system positively reducing both flexibility indicator values: total system cost and wind curtailment. On the other hand, in cases when EV are included, wasted wind penalization does not affect systems operation; neither in the reference case nor in other stages of decommission. Wind upward reserve provision causes decrease in cost and curtailment when no EVs are included, however, in scenarios with EV, provision of flexibility services from wind does not provide any additional benefits to power system operation.

## Acknowledgments

The work of the authors is a part of the Flex-ChEV – Flexible Electric Vehicle Charging Infrastructure project funded by Smart Grids ERA-Net under project grant No. 13 and SNOVI funded by the Croatian Environmental Protection and Energy Efficiency Fund through EnU-16/2015 program.

## References

- [1] Ortega-Vazquez MA, Kirschen DS. Estimating the spinning reserve requirements in systems with significant wind power generation penetration. *IEEE Trans Power Syst* 2009;24:114–24. <http://dx.doi.org/10.1109/TPWRS.2008.2004745>.
- [2] Ortega-Vazquez MA, Bouffard F, Silva V. Electric vehicle aggregator/system operator coordination for charging scheduling and services procurement. *IEEE Trans Power Syst* 2013;28:1806–15. <http://dx.doi.org/10.1109/TPWRS.2012.2221750>.
- [3] Ryan J, Ela E, Flynn D, O'Malley M. Variable generation, reserves, flexibility and policy interactions. In: 2014 47th Hawaii int conf syst sci. IEEE; 2014. p. 2426–34. <http://dx.doi.org/10.1109/HICSS.2014.304>.
- [4] Black M, Strbac G. Value of bulk energy storage for managing wind power fluctuations. *IEEE Trans Energy Convers* 2007;22:197–205. <http://dx.doi.org/10.1109/TEC.2006.889619>.
- [5] Pudjianto D, Aunedi M, Djapic P, Strbac G. Whole-systems assessment of the value of energy storage in low-carbon electricity systems. *IEEE Trans Smart Grid* 2014;5:1098–109. <http://dx.doi.org/10.1109/TSG.2013.2282039>.
- [6] Pandzic H, Wang Y, Qiu T, Dvorkin Y, Kirschen DS. Near-optimal method for siting and sizing of distributed storage in a transmission network. *IEEE Trans Power Syst* 2014;1–13. <http://dx.doi.org/10.1109/TPWRS.2014.2364257>.
- [7] Karangelos E, Bouffard F. Towards full integration of demand-side resources in joint forward energy/reserve electricity markets. *IEEE Trans Power Syst* 2012;27:280–9. <http://dx.doi.org/10.1109/TPWRS.2011.2163949>.

- [8] Gross G. Key issues and challenges in the deepening penetration of demand response resources; 2014. <<https://meetings.vtools.ieee.org/m/32397>> [accessed November 26, 2015].
- [9] Yang J, He L, Fu S. An improved PSO-based charging strategy of electric vehicles in electrical distribution grid. *Appl Energy* 2014;128:82–92. <http://dx.doi.org/10.1016/j.apenergy.2014.04.047>.
- [10] Neaimh M, Wardle R, Jenkins AM, Yi J, Hill G, Lyons PF, et al. A probabilistic approach to combining smart meter and electric vehicle charging data to investigate distribution network impacts. *Appl Energy* 2015;157:688–98. <http://dx.doi.org/10.1016/j.apenergy.2015.01.144>.
- [11] Jian L, Zheng Y, Xiao X, Chan CC. Optimal scheduling for vehicle-to-grid operation with stochastic connection of plug-in electric vehicles to smart grid. *Appl Energy* 2015;146:150–61. <http://dx.doi.org/10.1016/j.apenergy.2015.02.030>.
- [12] Sousa T, Morais H, Soares J, Vale Z. Day-ahead resource scheduling in smart grids considering Vehicle-to-Grid and network constraints. *Appl Energy* 2012;96:183–93. <http://dx.doi.org/10.1016/j.apenergy.2012.01.053>.
- [13] Liu W, Hu W, Lund H, Chen Z. Electric vehicles and large-scale integration of wind power – the case of Inner Mongolia in China. *Appl Energy* 2013;104:445–56. <http://dx.doi.org/10.1016/j.apenergy.2012.11.003>.
- [14] Schuller A, Flath CM, Gottwalt S. Quantifying load flexibility of electric vehicles for renewable energy integration. *Appl Energy* 2015;151:335–44. <http://dx.doi.org/10.1016/j.apenergy.2015.04.004>.
- [15] Meng J, Mu Y, Jia H, Wu J, Yu X, Qu B. Dynamic frequency response from electric vehicles considering travelling behavior in the Great Britain power system 2016;162:966–79. <http://dx.doi.org/10.1016/j.apenergy.2015.10.159>.
- [16] Zhong J, He L, Li C, Cao Y, Wang J, Fang B, et al. Coordinated control for large-scale EV charging facilities and energy storage devices participating in frequency regulation. *Appl Energy* 2014;123:253–62. <http://dx.doi.org/10.1016/j.apenergy.2014.02.074>.
- [17] Khazali A, Kalantar M. A stochastic-probabilistic energy and reserve market clearing scheme for smart power systems with plug-in electrical vehicles. *Energy Convers Manage* 2015;96:242–57. <http://dx.doi.org/10.1016/j.enconman.2015.02.070>.
- [18] Shafie-khah M, Moghaddam MP, Sheikh-El-Eslami MK, Catalão JPS. Optimised performance of a plug-in electric vehicle aggregator in energy and reserve markets. *Energy Convers Manage* 2015;97:393–408. <http://dx.doi.org/10.1016/j.enconman.2015.03.074>.
- [19] Teng F, Aunedi M, Strbac G. Benefits of flexibility from smart electrified transportation and heating in the future UK electricity system. *Appl Energy* 2015. <http://dx.doi.org/10.1016/j.apenergy.2015.10.028>.
- [20] Verzijlbergh R, Brancucci Martínez-Anido C, Lukszo Z, de Vries L. Does controlled electric vehicle charging substitute cross-border transmission capacity? *Appl Energy* 2014;120:169–80. <http://dx.doi.org/10.1016/j.apenergy.2013.08.020>.
- [21] Habib S, Kamran M, Rashid U. Impact analysis of vehicle-to-grid technology and charging strategies of electric vehicles on distribution networks – a review. *J Power Sources* 2015;277:205–14. <http://dx.doi.org/10.1016/j.jpowsour.2014.12.020>.
- [22] Green RC, Wang L, Alam M. The impact of plug-in hybrid electric vehicles on distribution networks: a review and outlook. *Renew Sustain Energy Rev* 2011;15:544–53. <http://dx.doi.org/10.1016/j.rser.2010.08.015>.
- [23] Richardson DB. Electric vehicles and the electric grid: a review of modeling approaches, impacts, and renewable energy integration. *Renew Sustain Energy Rev* 2013;19:247–54. <http://dx.doi.org/10.1016/j.rser.2012.11.042>.
- [24] Li T, Shahidepour M. Price-based unit commitment: a case of lagrangian relaxation versus mixed integer programming. *IEEE Trans Power Syst* 2005;20:2015–25. <http://dx.doi.org/10.1109/TPWRS.2005.857391>.
- [25] Carrion M, Arroyo JM. A computationally efficient mixed-integer linear formulation for the thermal unit commitment problem. *IEEE Trans Power Syst* 2006;21:1371–8. <http://dx.doi.org/10.1109/TPWRS.2006.876672>.
- [26] Dvorkin Y, Pandzic H, Ortega-Vazquez MA, Kirschen DS. A hybrid stochastic/interval approach to transmission-constrained unit commitment. *IEEE Trans Power Syst* 2015;30:621–31. <http://dx.doi.org/10.1109/TPWRS.2014.2331279>.
- [27] Meibom P, Barth R, Hasche B, Brand H, Weber C, O'Malley M. Stochastic optimization model to study the operational impacts of high wind penetrations in Ireland. *IEEE Trans Power Syst* 2011;26:1367–79. <http://dx.doi.org/10.1109/TPWRS.2010.2070848>.
- [28] Sturt A, Strbac G. Efficient stochastic scheduling for simulation of wind-integrated power systems. *IEEE Trans Power Syst* 2012;27:323–34. <http://dx.doi.org/10.1109/TPWRS.2011.2164558>.
- [29] Palmintier BS. *Incorporating operational flexibility into electric generation planning*. Massachusetts Institute of Technology; 2013.
- [30] Palmintier BS, Webster MD. Heterogeneous unit clustering for efficient operational flexibility modeling. *IEEE Trans Power Syst* 2014;29:1089–98. <http://dx.doi.org/10.1109/TPWRS.2013.2293127>.
- [31] Zhang L, Member S, Capuder T. Unified unit commitment formulation and fast multi-service lp model for flexibility evaluation in sustainable power systems; 2015. p. 1–14.
- [32] Kiviluoma J, Meibom P. Methodology for modelling plug-in electric vehicles in the power system and cost estimates for a system with either smart or dumb electric vehicles. *Energy* 2011;36:1758–67. <http://dx.doi.org/10.1016/j.energy.2010.12.053>.
- [33] Barth R, Brand H, Meibom P, Weber C. A stochastic unit-commitment model for the evaluation of the impacts of integration of large amounts of intermittent wind power. In: 2006 Int Conf Probabilistic Methods Appl to Power Syst. IEEE; 2006. p. 1–8. <http://dx.doi.org/10.1109/PMAPS.2006.360195>.
- [34] Pavić I, Capuder T, Kuzle I. Value of flexible electric vehicles in providing spinning reserve services. *Appl Energy* 2015;157:60–74. <http://dx.doi.org/10.1016/j.apenergy.2015.07.070>.
- [35] Ummels BC, Gibescu M, Pelgrum E, Kling WL, Brand AJ. Impacts of wind power on thermal generation unit commitment and dispatch. *IEEE Trans Energy Convers* 2007;22:44–51. <http://dx.doi.org/10.1109/TEC.2006.889616>.
- [36] Kubik ML, Coker PJ, Barlow JF. Increasing thermal plant flexibility in a high renewables power system. *Appl Energy* 2015;154:102–11. <http://dx.doi.org/10.1016/j.apenergy.2015.04.063>.
- [37] Denholm P, Hand M. Grid flexibility and storage required to achieve very high penetration of variable renewable electricity. *Energy Policy* 2011;39:1817–30. <http://dx.doi.org/10.1016/j.enpol.2011.01.019>.
- [38] Krajačić G, Duić N, Carvalho M. How to achieve a 100% RES electricity supply for Portugal? *Appl Energy* 2011;88:508–17.
- [39] Krajačić G, Duić N, Zmijarević Z, Mathiesen BV, Vučinić AA, da Graça Carvalho M. Planning for a 100% independent energy system based on smart energy storage for integration of renewables and CO<sub>2</sub> emissions reduction. *Appl Therm Eng* 2011;31:2073–83. <http://dx.doi.org/10.1016/j.applthermaleng.2011.03.014>.
- [40] Čosić B, Krajačić G, Duić N. A 100% renewable energy system in the year 2050: the case of Macedonia. *Energy* 2012;48:80–7. <http://dx.doi.org/10.1016/j.energy.2012.06.078>.
- [41] Tarroja B, Shaffer B, Samuelsen S. The importance of grid integration for achievable greenhouse gas emissions reductions from alternative vehicle technologies. *Energy* 2015;87:504–19. <http://dx.doi.org/10.1016/j.energy.2015.05.012>.
- [42] Božić D, Pantoš M. Impact of electric-drive vehicles on power system reliability. *Energy* 2015;83:511–20. <http://dx.doi.org/10.1016/j.energy.2015.02.055>.
- [43] Kirschen DS, Ma J, Silva V, Belhomme R. Optimizing the flexibility of a portfolio of generating plants to deal with wind generation. In: 2011 IEEE power energy soc gen meet. IEEE; 2011. p. 1–7. <http://dx.doi.org/10.1109/PES.2011.6039157>.
- [44] Ma J, Silva V, Belhomme R, Kirschen DS, Ochoa LF. Evaluating and planning flexibility in sustainable power systems. In: 2013 IEEE Power Energy Soc Gen Meet. IEEE; 2013. p. 1–11. <http://dx.doi.org/10.1109/PESMG.2013.6672221>.
- [45] Palmintier B. Flexibility in generation planning: identifying key operating constraints. In: 2014 Power syst comput conf. IEEE; 2014. p. 1–7. <http://dx.doi.org/10.1109/PSCC.2014.7038323>.
- [46] Shortt A, O'Malley M. Quantifying the long-term impact of electric vehicles on the generation portfolio. *IEEE Trans Smart Grid* 2014;5:71–83. <http://dx.doi.org/10.1109/TSG.2013.2286353>.
- [47] ENTSO-E WG Ancillary Services. Ancillary Services in Europe Contractual aspects; 2011. <[www.entsoe.eu/fileadmin/user\\_upload/\\_library/position\\_papers/ENTSO\\_BalancingMaps\\_Final.pdf](http://www.entsoe.eu/fileadmin/user_upload/_library/position_papers/ENTSO_BalancingMaps_Final.pdf)>.
- [48] Galiana FD, Bouffard F, Arroyo JM, Restrepo JF. Scheduling and pricing of coupled energy and primary, secondary, and tertiary reserves. *Proc IEEE* 2005;93:1970–83. <http://dx.doi.org/10.1109/JPROC.2005.857492>.
- [49] Aunedi M. *Value of flexible demand-side technologies in future low-carbon systems*. Imperial College London; 2013.
- [50] Silva V. *Value of flexibility in systems with large wind penetration*. University of London; 2010.
- [51] Gross R, Green T, Leach M, Skea J, Heptonstall P, Anderson D. The costs and impacts of intermittency; 2006. <http://dx.doi.org/10.1016/j.enpol.2008.06.013>.
- [52] National Grid, Winter Outlook 2013/14; 2013.
- [53] Teng F, Trovato V, Strbac G. Stochastic scheduling with inertia-dependent fast frequency response requirements. *IEEE Trans Power Syst* 2015;1–10. <http://dx.doi.org/10.1109/TPWRS.2015.2434837>.
- [54] Quan H, Srinivasan D, Khambadkone AM, Khosravi A. A computational framework for uncertainty integration in stochastic unit commitment with intermittent renewable energy sources. *Appl Energy* 2015;152:71–82. <http://dx.doi.org/10.1016/j.apenergy.2015.04.103>.
- [55] Dimitroulas DK, Georgilakis PS. A new memetic algorithm approach for the price based unit commitment problem. *Appl Energy* 2011;88:4687–99. <http://dx.doi.org/10.1016/j.apenergy.2011.06.009>.
- [56] Wang J, Wang J, Liu C, Ruiz JP. Stochastic unit commitment with sub-hourly dispatch constraints. *Appl Energy* 2013;105:418–22. <http://dx.doi.org/10.1016/j.apenergy.2013.01.008>.
- [57] Pavić I, Capuder T, Holjevac N, Kuzle I. Role and impact of coordinated EV charging on flexibility in low carbon power systems. In: 2014 IEEE int electr veh conf. IEEE; 2014. p. 1–8. <http://dx.doi.org/10.1109/IEVC.2014.7056172>.
- [58] Basis CG, Bakirtzis AG. Optimal yearly scheduling of generation and pumping for a price-maker hydro producer. In: 2010 7th Int conf Eur energy mark. IEEE; 2010. p. 1–6. <http://dx.doi.org/10.1109/EEM.2010.5558685>.
- [59] Cleary B, Duffy a, O'Connor a, Conlon M, Fthenakis V. Assessing the Economic benefits of compressed air energy storage for mitigating wind curtailment. *Sustain Energy, IEEE Trans* 2015;6:1021–8. <http://dx.doi.org/10.1109/TSTE.2014.2376698>.
- [60] Kane L, Ault G. Evaluation of wind power curtailment in active network management schemes. *IEEE Trans Smart Grids* 2015;30:8. <http://dx.doi.org/10.1109/TPWRS.2014.2336862>.
- [61] Grünwald P, McKenna E, Thomson M. Going with the wind: temporal characteristics of potential wind curtailment in Ireland in 2020 and

- opportunities for demand response. *IET Renew Power Gener* 2015;9:66–77. <http://dx.doi.org/10.1049/iet-rpg.2013.0320>.
- [62] Hozouri MA, Abbaspour A, Fotuhi-Firuzabad M, Moeini-Agtaie M. On the use of pumped storage for wind energy maximization in transmission-constrained power systems. *IEEE Trans Power Syst* 2015;30:1017–25. <http://dx.doi.org/10.1109/TPWRS.2014.2364313>.
- [63] Vargas LS, Bustos-Turu G, Larrain F. Wind power curtailment and energy storage in transmission congestion management considering power plants ramp rates. *IEEE Trans Power Syst* 2014;1–9. <http://dx.doi.org/10.1109/TPWRS.2014.2362922>.
- [64] Park H, Baldick R. Transmission planning under uncertainties of wind and load: sequential approximation approach. *IEEE Trans Power Syst* 2013;28:2395–402. <http://dx.doi.org/10.1109/TPWRS.2013.2251481>.
- [65] Ortega-Vazquez MA, Kirschen DS, Dvorkin Y. Wind generation as a reserve provider. *IET Gener Transm Distrib* 2015;9:779–87. <http://dx.doi.org/10.1049/iet-gtd.2014.0614>.

### **Publication 3**

I. Pavić, T. Capuder, and I. Kuzle, “A Comprehensive Approach for Maximizing Flexibility Benefits of Electric Vehicles,” *IEEE Systems Journal*, pp. 1–12, 2017, ISSN: 1932-8184. DOI: 10.1109/JSYST.2017.2730234



# A Comprehensive Approach for Maximizing Flexibility Benefits of Electric Vehicles

Ivan Pavić, *Student Member, IEEE*, Tomislav Capuder, *Member, IEEE*, and Igor Kuzle, *Senior Member, IEEE*

**Abstract**—Increasing variability and uncertainty coming from both sides of the power system equilibrium equation, such as wind energy on the generation side and increasing share of new consumers such as electric vehicles on the demand side, entail higher reserve requirements. While traditional approaches of assigning conventional generation units to maintain system stability can increase operational costs, greenhouse gas emissions, or give signals for new investments, utilizing intelligent control of distributed sources might mitigate those negative effects. This can be achieved by controllable charging of domestic electric vehicles. On the other hand, increasing number of public charging stations gives final users the opportunity to fast charge, making their vehicles an additional source of uncertainty rather than a provider of flexibility. This paper brings a full system assessment of combined effect of slow home charging of electric vehicles together with fast charging stations (both with and without integrated energy storage systems), cast as mixed integer linear programming unit commitment model. The contributions of this paper look into optimal periods when fast charging is beneficial for the system operation, as well as assess the benefits of integrating battery storage into fast charging stations to mitigate the negative effects to power system operation.

**Index Terms**—Ancillary services, battery storage system, electric vehicles (EVs), fast charging stations (FCS), power system flexibility, reserve provision.

## NOMENCLATURE

### Abbreviations

CPD	Conventional power demand.
EPS	Electrical power system.
ESS	Energy storage system.
EV	Electric vehicles.
FCS	Fast charging stations.
G2V	Grid to vehicle.
G2S	Grid to station.
HPP	Hydropower plants.
PRP	Primary reserve provision.
RES	Renewable energy sources.
S2G	Station to grid.
SEV	Slow electric vehicle (charging).
SOC	State-of-charge.

SRP	Secondary reserve provision.
TPP	Thermal power plants.
TSC	Total system cost.
TSE	Total system emissions.
UFC	Uncontrolled fast charging.
USC	Uncontrolled slow charging.
V2G	Vehicle to grid.
V2S	Vehicle to station.
WPC	Wind power curtailment.
WPP	Wind power plants.

## I. INTRODUCTION

Fossil fuel depletion and increasing environmental awareness are pushing modern societies to change their modus operandi by reducing nonrenewable energy consumption. Currently, more than 80% of total energy supply in the world relies on fossil fuels, where electricity generation and transportation systems are the biggest consumers [1]. Transition to nonfossil fuel driven economy is, therefore, seen through integration of renewable energy sources (RES) and society's willingness to accept lifestyle revisions such as transportation behavior changes. Although variable RES are a key factor in building environmentally efficient electrical power system (EPS), they introduce new challenges to traditional EPS operation. Variability and uncertainty of their primary source (wind speed, solar radiation) force conventional units to operate in nonoptimal operating points with higher number of intraday cycles. Additionally, integration of RES increases reserve requirements, which leads to higher total operational costs and emissions [2]. To fully exploit the benefits of RES, future power systems need to be flexible enough to cope with generation variations. Flexibility of EPS can be defined as the competence of EPS to balance power supply and demand through minimum cost provision of different services on multiple time scales. This capability of EPS is traditionally provided by conventional units and constrained by their technical characteristics. Nowadays, the focus is shifting to new concepts and technologies [3], [4] to provide required flexibility. A number of papers have been published analyzing the flexibility potential of energy storage systems (ESS) [5], [6], demand response [7], microgrids [8], multigeneration [9], EPS interconnection [10], and electric vehicles (EV).

This paper provides a comprehensive analysis of EV integration, focusing on mitigating negative effects of uncontrollable EV charging, in particular that of fast charging stations (FCS). Poorly designed EV charging infrastructure and management can generate new sources of imbalances and magnify system's flexibility requirements. The paper models EV behavior considering multiservice EPS with focus on a longer time scales (week, year) and different conditions/scenarios. The novelty of

Manuscript received September 23, 2016; revised March 7, 2017 and May 16, 2017; accepted July 8, 2017. Date of publication August 4, 2017; date of current version August 23, 2018. This work was supported in part by the Croatian Science Foundation under the project SUSTAINABLE CONCEPT for integration of distributed Energy Storage Systems (SUCCESS) and in part by the Croatian Science Foundation under the project Electric Vehicles Battery Swapping Station (IP-2014-09-3517). (Corresponding author: Ivan Pavić.)

The authors are with the Faculty of Electrical Engineering and Computing, University of Zagreb, Zagreb 10000, Croatia (e-mail: ivan.pavic@fer.hr; Tomislav.Capuder@fer.hr; igor.kuzle@fer.hr).

Digital Object Identifier 10.1109/JSYST.2017.2730234

the proposed approach is in modeling simultaneously both effects of slow, controllable charging and uncertain and variable FCS (not shown before). Similar analyses could be done for other demand response technologies, but due to the specific requirements of EV and succinctness of the paper, they are omitted from consideration. Specifically, this paper analyses how FCS impact the system operation and looks into different aspects of (non)coincidence of RES production and FCS operation. With this in mind, integrating ESS into FCS could mitigate larger reserve requirements of uncontrollable FCS but also act as an additional service provider.

It should be mentioned that analyzes in this paper do not attempt to provide a full economic benefits assessment of ESS integration (by incorporating their investment costs) and cost benefit analyses of such implementation, only operational aspects and benefits are the focus.

## II. LITERATURE REVIEW AND RELEVANT CONTRIBUTIONS

The concept of smart EV integration is, in recently published literature, usually seen through coordinated operation of EV and RES [11], [12], mitigation of variable and stochastic RES impact on the system operation [13], or through EV grid impacts [14], [15]. In the case where unit commitment of the entire system is considered, including the impact of EV on the provision of different services and, in particular, ancillary services as one of critical aspects of low carbon power system, FCS are neglected and their potentially negative impacts are not included in the modeling [16], [17]. To the authors' best knowledge, FCS have been analyzed only focusing on impacts on technical distribution grid constraints [18], [19] or included in models developed for distribution network planning, siting, and sizing [20], [21]. Additionally, FCS have been considered in the aggregators business concepts, maximizing revenues and defining business models for large FCS deployment [22], [23].

Potential of EV participation in ancillary services provision is discussed in [24] where authors conclude that providing negative secondary control is economically most beneficial for EV. In [25] and [26], EV aggregator model is proposed for participation in energy and reserve markets. Coordinated, aggregated participation of EV (slow charging) and battery storage stations along with conventional units in automatic frequency regulation is proposed in [27]. A new model for primary frequency control assessment is proposed in [28]. It was shown that PEVs can effectively improve system's frequency response following a disturbance. Another paper, [29], proposes EV as frequency controllers with goal to utilize more wind power. Papers listed in this paragraph describe the potential of EVs to provide ancillary services, however they do not consider the whole EPS operation nor the impact of both flexible slow or fast charging of EVs.

Stochastic optimization method has been developed in [30] for wind balancing using EV. Stochasticity of EV grid connection (unexpected EV interruptions) is modeled in [31]. Faria *et al.* [32] analyze EV charging impact on daily load diagram as well as detailed impact on local emissions of various particles. Detailed forecast tool for EV demand is provided in [33]; the presented model is very useful for both generation and demand side management of EV. Research in [34] provides stochastic UC MILP model used for study on slow charging EV impact on EPS flexibility under different charging patterns.

Work in [35] proposes day-ahead hourly unit commitment model in a power system composed of large-scale generators

and aggregated EV. The model described in this paper is a short-term dispatch model and observes only slow charging of EVs without considering the need for ancillary services. Shortt and O'Malley [36] and Ramirez *et al.* [37] propose interesting long-term planning models where EV impact on system expansion has been observed. Mathematical models are very detail, however EVs are once again modeled only as slow charging without considering EV participation in ancillary services provision.

None of the papers published focuses on the entire power systems modeled with all technical and economic constraints, analyzing both SEV and FCS impacts, and considering both energy and ancillary services. This paper continues authors' prior research in [38] and [39], where detailed analyses of SEV contribution to system flexibility are provided. Mentioned papers handle only SEV charging as a potential flexibility provider, whereas model in this paper adds up FCS both as flexibility sink and source. It is very important to point out that this paper uses the same input parameters and the same energy balance equation for both SEV and FCS (all research so far observed only one of them). Interaction of the two methods can suppress or enhance the total EV impact. Therefore, the main contributions of this paper can be defined as follows.

- 1) Design of multiservice (energy plus reserve provision) unit commitment model considering technical constraints and forecasts of conventional units, RES and EVs, cast as mixed integer linear program.
- 2) EVs are, for the first time, mathematically described as both slow charging (at home) and fast charging (at FCS) in the same model using the same driving patterns and the same fleet's SOC equation.
- 3) Assessment of combined slow and fast EV charging impact on EPS flexibility through different charging modes.
- 4) Finding the "optimal time window" for FCS charging with regards to SEV charging and other technical constraints.
- 5) Optimal SEV and FCS charging strategy selection in regards to EPS flexibility.
- 6) Defining the role of integrated ESS as a technology to mitigate the negative effects of FCS integration and as additional contributor to systems flexibility.

## III. PROBLEM FORMULATION

Described model captures techno-economic aspects of large-scale thermal and hydro generators, wind generators, conventional demand, and EVs. Even though the entire EPS is modeled, contributions of this paper are in EVs modeling. Therefore, only EV's (both SEV and FCS in Sections III-C, III-D, and III-E) formulations are explained. Details of the remaining mathematical formulations (Sections III-A and III-B) are for the most part omitted. Only the most relevant equations are provided. Readers are encouraged to find related papers where additional information can be found.

### A. Electric Power System Model

EPS is based on power generation-demand balance (1) and reserve provision-requirements balance (2)–(6). Considered EPS with service provision of different entities is illustrated in Fig. 1. Generation side, left side of (1), consists of the following.

- 1) Conventional units.
  - a) Thermal power plants (TPP)—denoted as  $p^{gTP}$ ;
  - i) nuclear power plants;

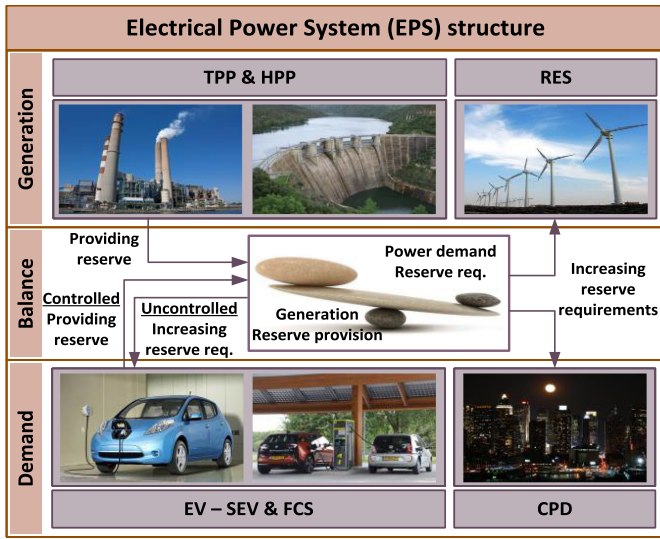

Fig. 1. Structure of observed EPS.

- ii) coal fueled power plants;
  - iii) combined cycle gas turbines;
  - iv) open cycle gas turbines.
  - b) Hydropower plants (HPP)—denoted as  $p^g\text{-HP}$ :
    - i) run-of-river;
    - ii) conventional HPP;
    - iii) pump storage—denoted as  $p^g\text{-PS}$ .
  - 2) Renewable energy sources.
    - a) Variable renewable energy:
      - i) wind power plants (WPP)—denoted as  $p^g\text{-WP}$ .
- On the other hand, the right side of (1) consists of the following.
- 3) Conventional power demand (CPD)—denoted as  $P^d$ .
  - 4) Electric vehicles:<sup>1</sup>
    - a) slow EV (SEV) charging ( $p^{c\text{-EV}}$ ) and dis. ( $p^{d\text{-EV}}$ );
    - b) FCS charging ( $p^{c\text{-FCS}}$ ) and discharging ( $p^{d\text{-FCS}}$ ).<sup>2</sup>

$$\begin{aligned}
 & \sum_{i=1}^{N_{i\text{-TP}}} (p_{t,i}^{g\text{-TP}}) + \sum_{i=1}^{N_{i\text{-HP}}} (p_{t,i}^{g\text{-HP}}) \\
 & + \sum_{i=1}^{N_{i\text{-PS}}} (p_{t,i}^{g\text{-PS}} - p_{t,i}^{p\text{-PS}}) + p_{t,i}^{g\text{-WP}} \\
 & = P_t^d + \sum_{i=1}^{N_{i\text{-EV}}} (p_{t,i}^{c\text{-EV}} - p_{t,i}^{d\text{-EV}}) + \sum_{i=1}^{N_{i\text{-FCS}}} \\
 & \quad \times (p_{t,i}^{c\text{-FCS}} - p_{t,i}^{d\text{-FCS}}). \quad (1)
 \end{aligned}$$

Ancillary services are the supporting services provided to EPS to enable continuous and stable flow of electricity from producer to consumer. Even though the term is used to refer to variety of operations, in this paper it refers to spinning reserve provision only. Reserve provision-requirements equations are defined for five different services as follows:

- 1) primary reserve up (2) and down (3);

<sup>1</sup>In mathematical expressions, SEVs charging and discharging is denoted as EV in the superscript not SEV.

<sup>2</sup>It should be noted that, with no additional storage, FCS do not actually provide V2G service and  $p^{d\text{-FCS}}$  variable takes the value of zero.

- 2) secondary reserve up (4) and down (5); and
- 3) tertiary reserve up (6).

$$\begin{aligned}
 & \sum_{i=1}^{N_{i\text{-TP}}} f_{t,i}^{\text{up-TP}} + \sum_{i=1}^{N_{i\text{-HP}}} f_{t,i}^{\text{up-HP}} + \sum_{i=1}^{N_{i\text{-EV}}} f_{t,i}^{\text{up-EV}} \\
 & + \sum_{i=1}^{N_{i\text{-FCS}}} f_{t,i}^{\text{up-FCS}} \geq F_t^{\text{up}} \quad (2)
 \end{aligned}$$

$$\begin{aligned}
 & \sum_{i=1}^{N_{i\text{-TP}}} f_{t,i}^{\text{dn-TP}} + \sum_{i=1}^{N_{i\text{-HP}}} f_{t,i}^{\text{dn-HP}} + \sum_{i=1}^{N_{i\text{-EV}}} f_{t,i}^{\text{dn-EV}} \\
 & + \sum_{i=1}^{N_{i\text{-FCS}}} f_{t,i}^{\text{dn-FCS}} \geq F_t^{\text{dn}} \quad (3)
 \end{aligned}$$

$$\begin{aligned}
 & \sum_{i=1}^{N_{i\text{-TP}}} r_{t,i}^{\text{up-TP}} + \sum_{i=1}^{N_{i\text{-HP}}} r_{t,i}^{\text{up-HP}} + \sum_{i=1}^{N_{i\text{-EV}}} r_{t,i}^{\text{up-EV}} \\
 & + \sum_{i=1}^{N_{i\text{-FCS}}} r_{t,i}^{\text{up-FCS}} \geq R_t^{\text{up}} \quad (4)
 \end{aligned}$$

$$\begin{aligned}
 & \sum_{i=1}^{N_{i\text{-TP}}} r_{t,i}^{\text{dn-TP}} + \sum_{i=1}^{N_{i\text{-HP}}} r_{t,i}^{\text{dn-HP}} + \sum_{i=1}^{N_{i\text{-EV}}} r_{t,i}^{\text{dn-EV}} \\
 & + \sum_{i=1}^{N_{i\text{-FCS}}} r_{t,i}^{\text{dn-FCS}} \geq R_t^{\text{dn}} \quad (5)
 \end{aligned}$$

$$\sum_{i=1}^{N_{i\text{-TP}}} q_{t,i}^{\text{up-TP}} \geq Q_t^{\text{up}}. \quad (6)$$

The left side of equations (2)–(6)<sup>3</sup> models all technologies capable of providing specific reserve (variables), while right side is calculated in advance and refers to deterministic reserve requirements (input time vectors).

Primary reserve requirements are usually fixed values defined by the loss of the largest generator in the system (or the largest loss of load), while secondary and tertiary reserve requirements depend on demand, wind, and EV forecasts (both SEV and FCS charging), shown in (7)–(11).  $R_t^{0,5h\text{-EV}}/R_t^{0,5h\text{-FCS}}$  represent SEV/FCS share in secondary reserve requirements, while  $R_t^{4h\text{-EV}}/R_t^{4h\text{-FCS}}$  represent their share in tertiary reserve. Please note that deterministic forecasts are used for future SEV and FCS power requirements (as well as for CPD and WPP); therefore,  $\sigma$  represents prediction error or deviation from the expected forecasted values, thus capturing the uncertainty of forecasts. Further explanations are provided in sections below.

$$\begin{aligned}
 & R_t^{0,5h\text{-EV}} \\
 & = \sum_{i=1}^{N_{i\text{-EV}}} \left( 3, 5 \cdot \sigma_t^{0,5h\text{-EV}} \cdot P_i^{\text{max-EV}} \cdot \sum_{\tau=t}^{(t-C_i^{\text{U-CH-EV}}+1)} N_{\tau,i}^{\text{arr-EV}} \right) \quad (7)
 \end{aligned}$$

<sup>3</sup>In the paper, tertiary reserve requirements are assumed to be provided only by offline TPPs.



$$R_t^{0,5h.FCS} = \sum_{i=1}^{N_{i.FCS}} \left( 3, 5 \cdot \sigma_t^{0,5h.FCS} \cdot \frac{P_i^{\max.FCS}}{3} \cdot \left( G_i^{EV} - N_{\tau,i}^{arr.EV} \right) \cdot \frac{p^{perf.EV}}{100} \right) \quad (8)$$

$$R_t^{up} = P^{gmax} + \sqrt{\left( 3 \cdot \sigma^d \cdot P_t^d \right)^2 + \left( 3, 5 \cdot \sigma_t^{(0,5h)-WP} \cdot P_t^{WP} \right)^2 + \left( R_t^{0,5h.EV} \right)^2 + \left( R_t^{0,5h.FCS} \right)^2} \quad (9)$$

$$R_t^{dn} = \sqrt{\left( 3 \cdot \sigma^d \cdot P_t^d \right)^2 + \left( 3, 5 \cdot \sigma_t^{(0,5h)-WP} \cdot P_t^{WP} \right)^2 + \left( R_t^{0,5h.EV} \right)^2 + \left( R_t^{0,5h.FCS} \right)^2} \quad (10)$$

$$Q_t^{up} = P^{gmax} + \sqrt{\left( 3 \cdot \sigma^d \cdot P_t^d \right)^2 + \left( 3, 5 \cdot \sigma_t^{(4h)-WP} \cdot P_t^{WP} \right)^2 + \left( R_t^{4h.EV} \right)^2 + \left( R_t^{4h.FCS} \right)^2} \quad (11)$$

Uncontrollable EV charging increases the reserve requirements due to uncertainty and variability of their arrival time at charging points and energy/power requirements; on the other hand, if EV charging is controlled/dispatchable, they are capable to provide reserve services. While TPP and HPP are conventional reserve providers, uncertain and variable CPD and WPP enhance the reserve requirements. Some papers have even considered WPP as reserve providers [40]. However, in the presence of flexible demand, such as controllable SEV, it has been shown that WPP are not preferred reserve providers since such concept does not fully utilize the renewable energy generation potential [39]. Additional information about reserve requirements and modeling can be found in [41].

The objective function of the UC model is the minimization of the operational costs, as shown in (12). Thermal unit's operational costs (startup, shutdown, fuel, greenhouse gas emissions), as well as those of hydro unit costs (O&M), are included. Thermal fuel consumption curve is modeled as three segments piecewise linear function as it is used in the U.S. electricity markets. For better understanding of the objective function, the reader is directed to [42]

$$\min \text{COST} = \sum_{t=1}^{N_t} \left[ \sum_{i=1}^{N_{i.TP}} (c_{t,i}^{TP}) + \sum_{i=1}^{N_{i.HP}} (c_{t,i}^{HP}) \right]. \quad (12)$$

### B. Generation Side Model

TPP and HPP models within unit commitment optimization are most commonly cast as binary problems. In order to improve computational efficiency of the UC model, TPP and HPP in this paper are clustered by technology type as in [43].

TPP generation is bounded by the following:

- 1) power generation constraints (three segment piecewise linear cost curve);
- 2) minimum up and down times;
- 3) ramping constraints;
- 4) reserve provision constraints;
- 5) greenhouse gas emission cost function.

HPP generation is subjected to:

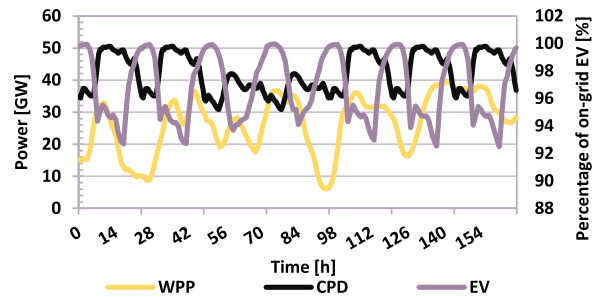

Fig. 2. WPP and CPD forecasts and EV's driving behavior.

- 1) water balance equation;
- 2) generation power constraints;
- 3) reservoir constraints;
- 4) hydro turbine constraints;
- 5) spillage constraint;
- 6) reserve provision constraints.

WPP generation is defined by real historical wind generation data (it can be seen as maximum wind power generation). Curtailment of WPP generation is allowed (production can be lower than historical/deterministic data). CPD has also been modeled as historic data, but it cannot be curtailed (strict constraint). Both WPP and CPD curves used in this paper are depicted in Fig. 2.

Due to the succinctness of this paper, mathematical formulations of UC operation are omitted from the paper but can be found in large number of recent publications [44]. Additional information (such as conventional units' technical data) can also be found in previous publications [38], [39]; the UC model presented in those papers is further expanded in the proposed contribution as shown in the following sections.

### C. EVs Model

Integration of EVs might result in increase of peak power demand or reserve requirements. On the other hand, availability to provide services to the system mostly depends on their driving/parking/charging curves. This main constraint for EV charging/discharging is based on real historical driving behavior curves. The main input parameters, such as the number of EV arriving to the charging spots ( $N_{t,i}^{arr.EV}$ ), number of EV leaving them ( $N_{t,i}^{leav.EV}$ ), and number of EV currently connected to the charging spots ( $N_{t,i}^{g.EV}$ ) are derived from the curves in report [45]. (13) presents energy balance equation where energy of the entire EV fleet ( $s_{t,i}^{EV}$ ) depends on fleet's energy in previous time step ( $t-1$ ), energy of vehicles arriving ( $s_{t,i}^{arr.EV}$ )/leaving ( $s_{t,i}^{leav.EV}$ ) charging spots, energy used for slow charging ( $p_{t,i}^{c.EV}$ ), energy injected back into the grid in the V2G mode ( $p_{t,i}^{d.EV}$ ), and energy used for fast charging/discharging ( $s_{t,i}^{add.FCS}$ ). (14) and (15) present initial and final charging conditions. Minimum and maximum capacity of EV fleet is constrained with (16). (17) and (18) present boundaries for EV energy upon arrival and departure from the charging spot (state of charge of the fleet);  $S^{cons.EV}$  is energy of one EV when arriving to the charging spot,  $S^{minc.EV}$  is minimum energy of EV when leaving it, while  $S^{rmax.EV}$  is the maximum battery capacity of one EV

$$s_{t,i}^{EV} = s_{t-1,i}^{EV} + s_{t,i}^{arr.EV} - s_{t,i}^{leav.EV} + p_{t,i}^{c.EV} \cdot \eta_i^{c.EV} \cdot \Delta t - p_{t,i}^{d.EV} / \eta_i^{d.EV} \cdot \Delta t + s_{t,i}^{add.FCS} \quad (13)$$

TABLE I  
SEV OPERATION MODES

		SEV – SLOW EV CHARGING		
		NR – No Reserve	YR – Yes Reserve	
Uncontrolled	<b>A</b>	USC – Uncon. Slow Charging	- EV slow charge at rated power from the moment they plug in until fully charged - EV do not impact reserve requirements	- EV slow charge at rated power from the moment they plug in until fully charged - EV causing increase in reserve requirements
	<b>B</b>	Unidirectional G2V – Grid to Vehicle	- EV optimal slow charging (in regards to EPS) - no EV discharging - no EV reserve provision	- EV optimal slow charging (in regards to EPS) - no EV discharging - EV provide reserve
Controlled	<b>C</b>	Bidirectional V2G – Vehicle to Grid	- EV optimal slow charging & discharging (in regards to EPS) - no EV reserve provision	- EV optimal slow charging & discharging (in regards to EPS) - EV provide reserve

$$s_{1,i}^{EV} = S_i^{0,EV} + s_{1,i}^{arr,EV} - s_{1,i}^{leav,EV} + p_{1,i}^{c,EV} \cdot \eta_i^{c,EV} \cdot \Delta t - p_{1,i}^{d,EV} / \eta_i^{d,EV} \Delta t + s_{1,i}^{add,FCS} \quad (14)$$

$$s_{Nt,i}^{EV} \geq S_i^{0,EV} \quad (15)$$

$$N_{t,i}^{g,EV} \cdot S_i^{\min,EV} + s_{t,i}^{arr,EV} - s_{t,i}^{leav,EV} + s_{t,i}^{add,FCS} \leq s_{t,i}^{EV} \leq N_{t,i}^{g,EV} \cdot S_i^{\max,EV} + s_{t,i}^{arr,EV} - s_{t,i}^{leav,EV} + s_{t,i}^{add,FCS} \quad (16)$$

$$N_{t,i}^{leav,EV} \cdot S_i^{\minc,EV} \leq s_{t,i}^{leav,EV} \leq N_{t,i}^{leav,EV} \cdot S_i^{\max,EV} \quad (17)$$

$$0 \leq s_{t,i}^{arr,EV} \leq N_{t,i}^{arr,EV} \cdot S_i^{\cons,EV} \quad (18)$$

As elaborated in previous sections, charging of EVs can be done in two different ways: 1) SEV charging, denoted with EV superscript and 2) fast EVs charging denoted with superscript FCS in all equations. Unified modeling approach shown in the above equations enables different analyses of these charging regimes.

#### D. SEV Charging Model

Slow charging of EVs corresponds to charging at home, in garage, at workplace, at road curbs, parking lots, etc. These locations offer charging at lower power rates but require longer charging times (up to 10 h). However, the impact of SEV charging on EV battery is less degrading and service should be cheaper than in the case of FCS. To investigate all possible impacts on EPS, SEV charging is modeled through six operating modes as follows (see Table I).

- 1) *Operating mode A*: Uncontrolled slow charging (USC; also in the literature known as dumb, plug-in, passive). This mode is analyzed in two scenarios: 1) where such mode has no impact on the reserve requirements (marked USC-NR), this is the most frequent approach in the available literature; 2) with impact/increase of the reserve requirements (marked USC-YR), thus capturing unknown times of EV arrival/departure and energy/power requirements.
- 2) *Operating mode B*: Controlled unidirectional EV operation (G2V, only charging) where EV can provide only energy and no reserve services (denoted as G2V-NR) and

multiple services, energy, and reserve (denoted as G2V-YR);

- 3) *Operating mode C*: Controlled bidirectional operation of EV (called V2G) where EV can be both charged and discharged. Again, the operating mode not only considers energy arbitrage participation (V2G-NR) but also energy and reserve provision by EV (V2G-YR).

In USC mode, power demand of EV passively and directly follows parking behavior of EV. EVs begin their charging immediately after they plug-in and charge until specific level of their battery's SOC has been reached. Discharging is not possible during USC as modeled by (19).  $C_i^{UCH,EV}$  in (20) corresponds to time required to fully charge EV at rated power.

$$p_{t,i}^{d,EV} = 0 \quad (19)$$

$$C_i^{UCH,EV} = \text{round} \left\{ \frac{S_i^{\max,EV} - S_i^{\cons,EV}}{P_i^{\max,EV} \cdot \Delta t \cdot \eta_i^{c,EV}} \right\} \quad (20)$$

EVs in USC modes charge within the range of 90–100% of their rated power, as shown in (21) and (22). (21) presents initial conditions for time steps  $1, \dots, C_i^{UCH,EV}$ .

$$\begin{aligned} & \sum_{\tau=Nt+t-C_i^{UCH,EV}+1}^{Nt} (N_{\tau,i}^{arr,EV} \cdot P_i^{\max,EV} \cdot 0,9) \\ & + \sum_{\tau=1}^t (N_{\tau,i}^{arr,EV} \cdot P_i^{\max,EV} \cdot 0,9) \leq p_{t,i}^{c,EV} \\ & \leq \sum_{\tau=Nt+t-C_i^{UCH,EV}+1}^{Nt} (N_{\tau,i}^{arr,EV} \cdot P_i^{\max,EV}) \\ & + \sum_{\tau=1}^t (N_{\tau,i}^{arr,EV} \cdot P_i^{\max,EV}). \end{aligned} \quad (21)$$

Equation (22) presents EV charging for a period of  $C_i^{UCH,EV}, \dots, Nt$

$$\begin{aligned} & \sum_{\tau=t-C_i^{UCH,EV}+1}^t (N_{\tau,i}^{arr,EV} \cdot P_i^{\max,EV} \cdot 0,9) \leq p_{t,i}^{c,EV} \\ & \leq \sum_{\tau=t-C_i^{UCH,EV}+1}^t (N_{\tau,i}^{arr,EV} \cdot P_i^{\max,EV}). \end{aligned} \quad (22)$$

Controlled unidirectional charging (G2V) of operational mode B is a flexible way of charging, EVs charge according to signals from the system/market operator, as shown in (24). EV discharging is not permitted in this mode (23). G2V mode, due to its controllability, allows primary reserve provision (PRP),  $r_{t,i}^{\uparrow,EV}$  and  $r_{t,i}^{\downarrow,EV}$  in (27) and (28), and secondary reserve provision (SRP),  $r_{t,i}^{\uparrow,EV}$  and  $r_{t,i}^{\downarrow,EV}$  in (25) and (26). EV can provide secondary upward/downward reserve with decrease/increase in their scheduled charging power. PRP is defined in the same manner, but it considers already allocated SRP

$$p_{t,i}^{d,EV} = 0 \quad (23)$$

$$P_i^{\min,EV} \cdot N_{t,i}^{g,EV} \leq p_{t,i}^{c,EV} \leq P_i^{\max,EV} \cdot N_{t,i}^{g,EV} \quad (24)$$

$$r_{t,i}^{\uparrow,EV} \leq p_{t,i}^{c,EV} \quad (25)$$

$$r_{t,i}^{\text{dn, EV}} \leq P_i^{\text{max, EV}} \cdot N_{t,i}^{\text{g, EV}} - p_{t,i}^{\text{c, EV}} \quad (26)$$

$$f_{t,i}^{\text{up, EV}} \leq p_{t,i}^{\text{c, EV}} - r_{t,i}^{\text{up, EV}} \quad (27)$$

$$f_{t,i}^{\text{dn, EV}} \leq P_i^{\text{max, EV}} \cdot N_{t,i}^{\text{g, EV}} - p_{t,i}^{\text{c, EV}} - r_{t,i}^{\text{dn, EV}}. \quad (28)$$

In operational mode C, controlled bidirectional mode (V2G), EVs are charged (30) and discharged (31) when they bring benefits to power system operation. Integer variable  $x_{t,i}^{\text{c, EV}}$  in (29) corresponds to the number of EV currently charging, while  $(N_{t,i}^{\text{g, EV}} - x_{t,i}^{\text{c, EV}})$  corresponds to the number of EV discharging

$$0 \leq x_{t,i}^{\text{c, EV}} \leq N_{t,i}^{\text{g, EV}} \quad (29)$$

$$P_i^{\text{min, EV}} \cdot x_{t,i}^{\text{c, EV}} \leq p_{t,i}^{\text{c, EV}} \leq P_i^{\text{max, EV}} \cdot x_{t,i}^{\text{c, EV}} \quad (30)$$

$$P_i^{\text{min, EV}} \cdot (N_{t,i}^{\text{g, EV}} - x_{t,i}^{\text{c, EV}}) \leq p_{t,i}^{\text{d, EV}} \leq P_i^{\text{max, EV}} \cdot (N_{t,i}^{\text{g, EV}} - x_{t,i}^{\text{c, EV}}). \quad (31)$$

Similar to G2V, bidirectional V2G operational model can contribute to PRP, modeled as  $f_{t,i}^{\text{up, EV}}$  and  $f_{t,i}^{\text{dn, EV}}$  in (34) and (35), and SRP, modeled as  $r_{t,i}^{\text{up, EV}}$  and  $r_{t,i}^{\text{dn, EV}}$  in (32) and (33), respectively. SRP up can be provided by decrease in EV charging power or by increase in EV discharging power. On the other side, downward reserve can be provided by EV charging power increase or discharging power decrease. PRP is defined in the same manner, but it also takes already allocated SRP into account

$$r_{t,i}^{\text{up, EV}} \leq P_i^{\text{max, EV}} \cdot (N_{t,i}^{\text{g, EV}} - x_{t,i}^{\text{c, EV}}) - p_{t,i}^{\text{d, EV}} + p_{t,i}^{\text{c, EV}} - P_i^{\text{min, EV}} \cdot x_{t,i}^{\text{c, EV}} \quad (32)$$

$$r_{t,i}^{\text{dn, EV}} \leq p_{t,i}^{\text{d, EV}} - P_i^{\text{min, EV}} \cdot (N_{t,i}^{\text{g, EV}} - x_{t,i}^{\text{c, EV}}) + P_i^{\text{max, EV}} \cdot x_{t,i}^{\text{c, EV}} - p_{t,i}^{\text{c, EV}} \quad (33)$$

$$f_{t,i}^{\text{up, EV}} \leq P_i^{\text{max, EV}} \cdot (N_{t,i}^{\text{g, EV}} - x_{t,i}^{\text{c, EV}}) - P_{t,i}^{\text{d, EV}} + p_{t,i}^{\text{c, EV}} - P_i^{\text{min, EV}} \cdot x_{t,i}^{\text{c, EV}} - r_{t,i}^{\text{up, EV}} \quad (34)$$

$$f_{t,i}^{\text{dn, EV}} \leq p_{t,i}^{\text{d, EV}} - P_i^{\text{min, EV}} \cdot (N_{t,i}^{\text{g, EV}} - x_{t,i}^{\text{c, EV}}) + P_i^{\text{max, EV}} \cdot x_{t,i}^{\text{c, EV}} - p_{t,i}^{\text{c, EV}} - r_{t,i}^{\text{dn, EV}}. \quad (35)$$

### E. FCS Model

Integration of FCS is gaining momentum in recent years. Many distribution system operators, or private investors, are installing public FCS with high rated power. The main issue concerning FCS is not their consumed energy throughout day but their high peak demand. Fast charging service should be more expensive than SEV regime due to higher impact on grid's technical constraints (such as voltage congestions) and peak generation scheduling. Some recent research suggests that there are benefits of integrating ESS with FCS; in these conditions, the service for the final consumer remains fast, while the impact on the grid and the system is reduced. As mentioned before, this paper does not attempt to find economic justification for investments in ESS, it provides an insight in its positive impact on the system operation. Following on this, this paper considers ESS as integrated part of FCS, but it can be used or omitted depending

TABLE II  
FCS OPERATION MODES

		FCS – FAST CHARGING STATIONS	
		NR – No Reserve	YR – Yes Reserve
Uncontrolled	CHARGING\RESERVE		
	D	UFC – Uncon. Fast Charging	UFC – Yes Reserve
Controlled	E	G2S – Grid to Station	G2S – Yes Reserve
		F	S2G – Station to Grid

on the services and scenarios analyzed. FCS is modeled by six potential operating modes (see Table II)

- 1) *Operating mode D*: Uncontrolled fast charging (UFC) without reserve requirements impact (UFC-NR) and increasing the reserve requirements (UFC-YR). The explanations are similar to the mode A of SEV, however the potential impact on requirements is much higher.
- 2) *Operating mode E*: Controlled unidirectional grid-to-station mode (called G2S, where fast charging is conducted by using ESS as a buffer to mitigate large power requirements). Again, two cases are analyzed: 1) FCS with reserve provision capability in G2S-YR scenario (capability of ESS to provide reserve services); and 2) without reserve provision capability in G2S-NR;
- 3) *Operating mode F*: Controlled bidirectional station-to-grid operation (called S2G, where FCS use ESS as interface with the grid, reducing the charging/discharging impact). Similar to the first two, this operating mode is analyzed for concepts when ESS can provide only energy arbitrage (S2G-NR) and energy arbitrage and reserve services (S2G-YR).

Modeling of FCS needs to be observed through three stages: 1) availability and the number of EV to be charged by FCS; 2) modeling ESS as a potential buffer of FCS and grid/system (if used); and 3) operating mode (both uncontrollable and controllable through integrated ESS).

EV fast charging requirements are modeled with (36) and (37). In (36), the minimum expected fast charging power is defined, as expected percentage of on-road fast charging EV. It is modeled using  $p_t^{\text{perf, EV}}$ , which can either be a constant value or a decision variable (when used in the scenarios for determining the optimal fast charging time window) as modeled in (37). Opposite to SEV charging, where upper boundary for EV charging power is defined by the number of EVs parked, the requirements for EV to be fast charged are defined by the number of on-road EV ( $G_i^{\text{EV}} - N_{t,i}^{\text{g, EV}}$ )

$$p_{t,i}^{\text{f, EV}} \geq p_t^{\text{perf, EV}} \cdot P_i^{\text{fmax, EV}} \cdot (G_i^{\text{EV}} - N_{t,i}^{\text{g, EV}}) \quad (36)$$

$$P_i^{\text{perfmin, EV}} \leq p_t^{\text{perf, EV}} \leq P_i^{\text{perfmax, EV}}. \quad (37)$$

Additionally, optional constraint for optimal fast charging is modeled by (38) where fast charging during a particular period (of length  $N_p$ ) is defined by a minimum percentage of total EV energy demand ( $P^{\text{enf.EV}}$ ), meaning that a certain percentage of EV must be fast charged. This needs to be satisfied during periods  $k$ , ensuring minimum customer satisfaction if fast charging is allowed only during “optimal” periods in the day

$$\sum_{T=1+N_p*k}^{N_p*(k+1)} \begin{pmatrix} p_{t,i}^{\text{c.EV}} \cdot \eta_i^{\text{c.EV}} \cdot \Delta t \\ -p_{t,i}^{\text{d.EV}} \cdot \eta_i^{\text{d.EV}} \cdot \Delta t + s_{t,i}^{\text{add.FCS}} \end{pmatrix} \cdot P^{\text{enf.EV}} \leq \sum_{T=1+N_p*k}^{N_p*(k+1)} (s_{t,i}^{\text{add.FCS}}). \quad (38)$$

If EV can be charged by fast chargers, the decision variable  $s_{t,i}^{\text{add.FCS}}$ , in (13) and (14), contributes to total EV energy demand. The energy and the time of use of fast charging is defined with the duration of EV travel time  $T_i^{\text{dur.EV}}$ , modeling the connection between FCS requirements and energy of EV battery. (39) presents initial conditions and is valid for time steps  $1, \dots, \text{arr}_i^{\text{EV}}$ . (40) defines additional energy for FCS in the remaining time steps

$$s_{t,i}^{\text{add.FCS}} \leq \eta_i^{\text{f.EV}} \cdot p_{(N_{t+T}^{\text{dur.EV}},i)}^{\text{f.EV}} \cdot \Delta t \quad (39)$$

$$s_{t,i}^{\text{add.FCS}} \leq \eta_i^{\text{f.EV}} \cdot p_{(t-T^{\text{dur.EV}},i)}^{\text{f.EV}} \cdot \Delta t. \quad (40)$$

(41)–(44) model storage (ESS) integrated in FCS. Integrated ESS prevents large power spikes in peak demand periods. From the system/grid point of view storage provides energy arbitrage and acts as a flexibility provider, while on the EV side it provides fast charging and thus satisfies customers’ requirements for fast service. Equation (41) presents energy balance equation for FCS with ESS.  $c_{t,i}^{\text{FCS}}$  is the current state of charge of ESS. It is equal to energy in previous ( $t-1$ ) state  $c_{t-1,i}^{\text{FCS}}$  plus energy “fast charged” to EV,  $p_{t,i}^{\text{f.EV}}$ , and energy exchanged by ESS and the system/grid expressed through ESS charging ( $p_{t,i}^{\text{c.FCS}}$ ) and discharging ( $p_{t,i}^{\text{d.FCS}}$ )

$$\sum_{i=1}^{N_i.\text{FCS}} c_{t,i}^{\text{FCS}} \leq \sum_{i=1}^{N_i.\text{FCS}} c_{t-1,i}^{\text{FCS}} \cdot k_i^{\text{loss.FCS}} - \sum_{i=1}^{N_i.\text{FCS}} p_{t,i}^{\text{f.FCS}} / \eta_i^{\text{fc.EV}} \cdot \Delta t + \sum_{i=1}^{N_i.\text{FCS}} p_{t,i}^{\text{c.FCS}} \cdot \eta_i^{\text{c.FCS}} \cdot \Delta t - \sum_{i=1}^{N_i.\text{FCS}} p_{t,i}^{\text{d.FCS}} / \eta_i^{\text{d.FCS}} \cdot \Delta t. \quad (41)$$

Equations (42) and (43) present initial and final conditions of ESS FCS

$$\sum_{i=1}^{N_i.\text{FCS}} c_{1,i}^{\text{FCS}} \leq \sum_{i=1}^{N_i.\text{FCS}} C_i^{0.\text{FCS}} \cdot k_i^{\text{loss.FCS}} - \sum_{i=1}^{N_i.\text{FCS}} p_{1,i}^{\text{f.FCS}} / \eta_i^{\text{fc.EV}} \cdot \Delta t + \sum_{i=1}^{N_i.\text{FCS}} p_{1,i}^{\text{c.FCS}} \cdot \eta_i^{\text{c.FCS}} \cdot \Delta t - \sum_{i=1}^{N_i.\text{FCS}} p_{1,i}^{\text{d.FCS}} / \eta_i^{\text{d.FCS}} \cdot \Delta t \quad (42)$$

$$c_{N_t,i}^{\text{FCS}} \geq C_i^{0.\text{FCS}} \cdot G_i^{\text{FCS}} \quad (43)$$

FCS energy storage boundaries are defined as

$$C_i^{\text{min.FCS}} \cdot G_i^{\text{FCS}} \leq c_{t,i}^{\text{FCS}} \leq C_i^{\text{max.FCS}} \cdot G_i^{\text{FCS}}. \quad (44)$$

In UFC mode, EVs are directly connected to grid (there is no ESS). Power for EV fast charging ( $p^{\text{f.FCS}}$ ) is equal to the power withdrawn from the grid/system ( $p^{\text{c.FCS}}$ ), shown in (45). If there is no ESS, the EV have no capability of discharging, as shown by (46). This operating mode depends only on EV driving/charging behavior; thus, it becomes an uncontrollable stochastic value. The impact of such charging regime on reserve requirements can only be negative, i.e., it increases reserve requirements as modeled in (8)–(11)

$$p_{t,i}^{\text{c.FCS}} = p_{t,i}^{\text{f.FCS}} \quad (45)$$

$$p_{t,i}^{\text{d.FCS}} = 0. \quad (46)$$

On the other hand, controlled unidirectional fast charging mode (G2S) requires ESS integration into FCS to alleviate unpredictable and variable behavior of EV fast charging demand. FCS are again used as platform for EV fast charging but EVs are not directly connected to the grid. The ESS acts as a mediator and charges during periods when it brings benefits to the EPS (47). By doing so, it allows EV to fast charge whenever they prefer, maintaining EV owners’ comfort. Reserve modeling is similar as in SEV reserve provision and shown by (48)–(51)

$$P_i^{\text{min.FCS}} \cdot G_i^{\text{FCS}} \leq p_{t,i}^{\text{c.FCS}} \leq P_i^{\text{max.FCS}} \cdot G_i^{\text{FCS}} \quad (47)$$

$$r_{t,i}^{\text{up.FCS}} \leq p_{t,i}^{\text{c.FCS}} \quad (48)$$

$$r_{t,i}^{\text{dn.FCS}} \leq P_i^{\text{max.FCS}} \cdot G_i^{\text{FCS}} - p_{t,i}^{\text{c.FCS}} \quad (49)$$

$$f_{t,i}^{\text{up.FCS}} \leq p_{t,i}^{\text{c.FCS}} - r_{t,i}^{\text{up.FCS}} \quad (50)$$

$$f_{t,i}^{\text{dn.FCS}} \leq P_i^{\text{max.FCS}} \cdot G_i^{\text{FCS}} - p_{t,i}^{\text{c.FCS}} - r_{t,i}^{\text{dn.FCS}}. \quad (51)$$

Controlled bidirectional fast charging mode (S2G) is similar to G2S mode, modeled with (52), adding the exception of FCS discharging as in (53). Integer variable  $x_{t,i}^{\text{c.FCS}}$  corresponds to the number of FCS currently charging, while expression ( $G_i^{\text{FCS}} - x_{t,i}^{\text{EV}}$ ) corresponds to the number of FCS currently discharging. Reserves are modeled in the same manner



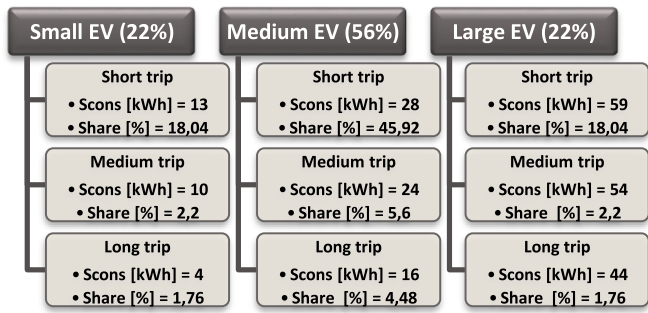

Fig. 3. EV types.

as SEV reserve provision

$$P_{i,\min}^{\text{FCS}} \cdot x_{t,i}^{c,\text{FCS}} \leq p_{t,i}^{c,\text{FCS}} \leq P_{i,\max}^{\text{FCS}} \cdot x_{t,i}^{c,\text{FCS}} \quad (52)$$

$$P_{i,\min}^{\text{FCS}} \cdot (G_i^{\text{FCS}} - x_{t,i}^{c,\text{FCS}}) \leq p_{t,i}^{d,\text{FCS}} \leq P_{i,\max}^{\text{FCS}} \cdot (G_i^{\text{FCS}} - x_{t,i}^{c,\text{FCS}}). \quad (53)$$

#### IV. CASE STUDIES

The value of the proposed model will be shown using two case studies. The first analysis attempts to find an optimal time window for EV fast charging. The goal of these simulations is to analyze if an optimal charging time for fast charging of EV, without integrated ESS, exists.

In the second part, the analyses focus on determining the impact of fast charging EV on power systems flexibility. In these analyses, the flexibility will be evaluated through three flexibility metrics: total system cost (TSC), total system emissions (TSE), and wind power curtailment (WPC). General idea behind those three metrics is as follows: If flexibility of the system is decreasing then conventional system components work in nonoptimal operating points and have higher number of startups, consequently it means higher TSC and TSE. Lower flexibility also means the degraded capability of integrating wind power (WPC increases).

##### A. Simulation Parameters

Considered energy mix is similar to U.K. power system energy mix [38]. Vehicles driving behavior is taken from [45] and it has been used for calculation of number of vehicles arriving and leaving the charging stations (same as in [38]). Three different EV battery capacities and trip lengths have been modeled along with their different shares in total EV fleet, forming nine EV types (see Fig. 3). EV-type shares are calculated combining percentages of particular trip length (last row in Table III, coming from [45]) and future projections of EV types share in total EV fleet (highest priority row in Fig. 3, obtained from [46]). Energy conserved at the end of the trip is calculated using battery capacity, travel length, and average consumption.

The remaining EV technical characteristics are gathered from different publications and they are displayed in Table III (e.g., EV slow charging power used is 3.7 kW—IEC 61851 one phase ac connection, and fast charging power is 62.5 kW—ChadeMo). In this paper, EVs are leaving the grid fully charged,  $S_i^{\text{min},\text{EV}} = S_i^{\text{max},\text{EV}}$ . Initial energy of each EV type ( $S_i^{0,\text{EV}}$ ) is equal to 60% of battery capacity of initial on-grid EV.

Three different types/sizes of FCS have been observed as presented in Table II. Data for particular FCS type are calculated

 TABLE III  
EV INPUT DATA

Power	$P^{\min}$ [kW]	0,37	$\eta^c, \eta^d, \eta^{fc}$	0,95
	$P^{\max}$ [kW]	3,7	$P^{\text{max}}$ [kW]	50
EV size	$S^{\min}$ [kWh]	Small	3,2	
		Medium	6,4	
		Large	12,8	
	$S^{\max}$ [kWh]	Small	16	
		Medium	32	
		Large	64	
Average consumption [kWh/km]	Small	0,15		
	Medium	0,2		
	Large	0,25		
Trip length (km)	Short	20		
	Medium	40		
	Long	80		
Trip duration – Arr iv. (h)	Short	0,5		
	Medium	1		
	Long	1,5		
Percentage of the trips [%]	Short	82		
	Medium	10		
	Long	8		

 TABLE IV  
FCS INPUT DATA

Power energy loss		
$\eta^c, \eta^d$		0,95
$k_{\text{loss}}^c$		0,98
FCS type		
$P^{\min}$ [kW]	Small	50
	Medium	150
	Large	500
$P^{\max}$ [kW]	Small	500
	Medium	1500
	Large	5000
$S^{\min}$ [kWh]	Small	200
	Medium	600
	Large	2000
$S^{\max}$ [kWh]	Small	1000
	Medium	3000
	Large	10000
FCS type share [%]	Small	50
	Medium	35
	Large	15
Max charg. number of EV (#)	Small	10
	Medium	30
	Large	100

based on the number of EV that can be charged in every time step at full power (last row in Table IV). The total number of FCS ( $G_1^{\text{FCS}}$ ) considers that all on-road EV can be fast charged (in other words, if it is “optimal for EPS,” fast charging could be done without ESS). FCS/ESS capacities are calculated so they can fully recharge for eight hours at rated power.

The initial U.K. like power system (details are in [38]) energy mix is around 35% nuclear power plants, 45% coal power plants, 15% combined cycle gas turbines, and 5% open cycle gas turbines. For these analyses, a percentage of 40% WPP integration is used with peak net demand of around 60 GW. Percentage of EV integration is expressed as the share of EV in today’s



TABLE V  
OPTIMAL FAST CHARGING TIME WINDOW—FLEXIBILITY INDICATORS FOR UFC CHARGING MODE

Slow charging modes	USC-YR			G2V-YR		
Uncontrolled Fast Charging Scenarios UFC	5%	0–12%	0–12 + 50% E	5%	0–12%	1–12 + 50% E
Total System Cost TSC [%]	−0,31	−1,27	−1,04	0,61	0,02	0,22
Total System Emissions TSE [%]	−0,06	−0,83	−0,57	−0,55	−0,02	0,25
Wind Power Curtailment WPC [%]	0,87	−9,47	−2,33	0,00	0,00	0,00
Peak Demand Increase PDI [%]	−2,68	7,95	1,18	−7,43	0,00	−9,51
Energy supplied through FCS [%]	25,78	38,96	50,03	27,69	2,49	54,23

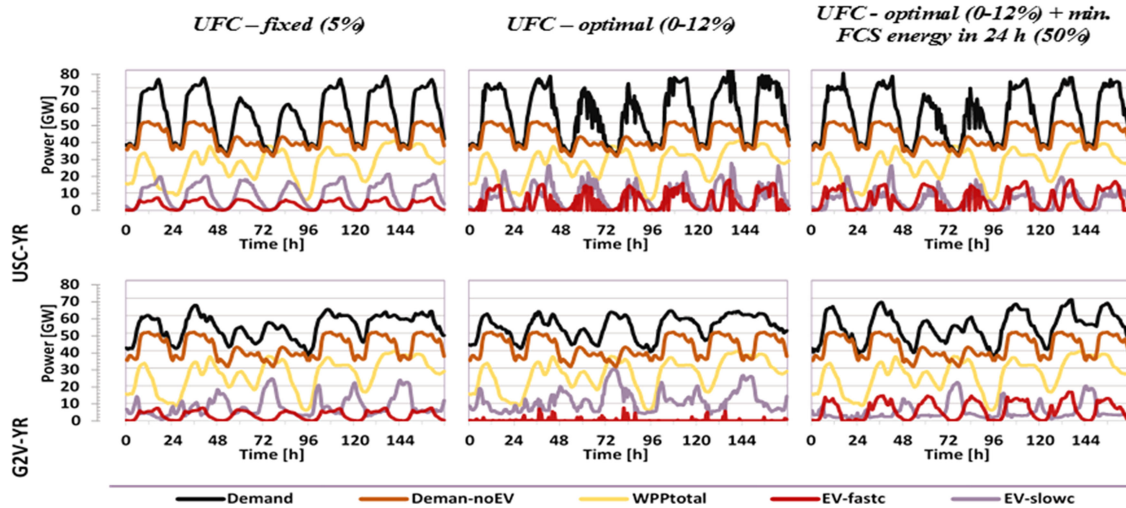

Fig. 4. Optimal fast charging time window—graphical result.

vehicle fleet in UK. It can be translated to EV maximum power; for example, total conventional vehicle fleet in U.K. today is around 30 million cars [47] and replacing 10% of them with EV increases U.K. peak power demand by 20% (if they all slow charged at daily peak power).

### B. Optimal Fast Charging Time Window

This section will try to discover whether an optimal fast charging window ever exists, i.e., can the power system ever benefit from uncontrolled FCS (taking into account flexibility that is already consumed or brought to EPS by SEV charging). By allowing different shares of on-road EV to fast charge at each moment makes fast charging partially controllable but at the cost of EV drivers comfort. For example, it can be observed as discounts offered to FCS for charging at specific time (“happy hours”) in order to change their behavior. On the other hand, controllable fast charging (G2S and S2G, or FCS with integrated ESS) provides controlled charging at FCS without any effect on EV drivers behavior.

Following on this, two SEV operational modes are analyzed in combination with FCS; USC-YR (operational mode A, increasing reserve due to uncontrollability, “dumb” charging), as inflexible operating regime, and G2V-YR, as source of additional flexibility (operational mode B, providing flexibility as reserve due to controllable charging).

Each of the two SEV modes is combined with fast charging, three different UFC scenarios have been simulated as follows.

- 1) Fixed percentage of on-road EV that are allowed to fast charge ( $P_{\text{tperf\_EV}} = 5\%$ ), while the remaining 95% is using slow charging.

- 2) A certain percentage of up to 12% of on-road EV can fast charge (this is modeled by (37), variables  $P_{\text{perfm\_EV}} = 0\%$ ,  $P_{\text{perfm\_max\_EV}} = 12\%$ ).
- 3) Variable percentage of EV is fast charged; however, there is a minimum required energy “assigned” for fast charging throughout the day (modeled with (37) and (38),  $P_{\text{enf\_EV}} = 50\%$ ). In this section, 100% vehicles are considered electric.

Results of the simulations are shown in Table V and Fig. 4 for one-week time horizon. It can be noticed that in case with predefined fixed number of “dumb” fast charging EV (first column of Fig. 2), fast charging patterns are very similar for both SEV charging modes. As expected, such charging behavior results in peak demand increase, in case of uncontrollable slow charging, UCH-YR, the power demand increase (PDI) is around 54%, while in controllable slow charging regime, G2V-YR, PDI increases by 28%. The explanation is rather simple; controllable SEV charging is alleviating negative effects of FCS by shifting its charging during the night and using as much wind as possible during low demand periods (load leveling). This can be seen in Fig. 4, as slow charging EV curve and fast charging curve almost never occur at the same time. Comparing peak demands of the system with the case of only SEV charging (see Table V), introduction of FCS slightly decreases the peak demand in both USC-YR (−2.68%) and G2V-YR (−7.43%). On the other hand, its effect on other flexibility metrics is negligible (operational cost, greenhouse gas emissions, and wind curtailment). In the second case (second column of Fig. 4), the algorithm finds optimal fast charging time windows for fast charging. In case of uncontrollable slow charging mode, all flexibility metrics are slightly improved/decreased compared to fixed UFC; TSC,

TSE around 1%, while WPC is reduced by 9.47%. It is interesting to notice that peak demand increases (by 7.95%). This happens because the objective function of the algorithm pushes the minimization of WPC and during the few specific peak demand moments, when there is an excess of wind, fast charging is deployed (total demand is increased). Since UCH-YR mode is inflexible, the capability of creating optimal fast charging windows brings additional flexibility. Fast charging will be a preferred option in those scenarios, encouraging all EV to fast charge, and, by doing so, increasing fast charging energy from 26% to 39% (FCS in Table V represents percentage of total required energy by EV provided through fast charging). It is interesting to notice that peak demand increases (by 7.95%). This happens since the objective function pushes the minimization of WPC and during the few specific peak demand moments when there is an excess of wind, fast charging is deployed (total demand is increased). UCH-YR mode is inflexible SEV charging mode and optimal fast charging provides new flexibility, meaning fast charging will be a preferred option in those scenarios increasing fast charging energy from 26% to 39% (FCS in Table V represents percentage of total required energy by EV provided through fast charging).

Due to high flexibility of the G2V-YR mode, there is no need for optimal fast charging windows and the end result is that all EVs have been controllably slow charged. In scenario where 50% of energy is being used for fast charging, both observed scenarios (third column of Fig. 4) show poorer results as system has been moved from its optimal point.

As a general conclusion, introduction of fast charging has minimal effect on defined flexibility metrics when comparing to flexible and inflexible SEV charging with 0% FCS. Uncontrollable charging, both slow in (USC-YR) and fast (UFC), depends on driving behavior of EVs and their charging occurs during peak daytime periods. Since they are both inflexible regimes, their effect on EPS is similar. On the other hand, G2V-YR incorporates high flexibility and can alleviate negative impacts of inflexible fast charging behavior.

### C. Charging Station Impact on System's Flexibility

To evaluate the impact of fast charging on system's flexibility, the following analyses have been considered: 1) uncontrollable USC-YR with the addition of fixed 5% on-road vehicles fast charging and 2) controllable G2V-YR with the addition of fixed 5% on-road vehicles fast charging. Since there is a lack of real data on EV fast charging, we assume these percentages. In both analyses, six FCS operating modes and two EV shares have been used: 33% and 67%<sup>4</sup> (of total U.K. vehicle's fleet as EVs). The results are shown in Figs. 5 and 6, using 0% of fast charging EVs as base case for comparing (all EVs have been slow charged in base case).

Analyzing the results for uncontrollable SEV charging (see Fig. 5), USC-YR mode, it can be noticed that FCS coupled with ESS as a reserve provider (G2S-YR and S2G-YR) reduces all flexibility metric values, increasing the power system flexibility. In case of 67% of EVs, reduction of wind curtailment metric (WPC) is higher than for 33%, while the operating cost (TSC) and system emissions (TSE) reduction is lower. This suggests that larger share of USC-YR impacts EPS flexibility more than it gains from utilizing G2S and S2G reserve provision. Controlled

<sup>4</sup>The results for 100% are very similar as for 67%, therefore they are omitted from the paper.

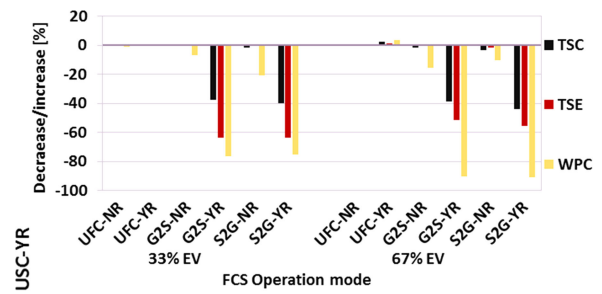

Fig. 5. FCS impact on EPS flexibility metrics USC-YR.

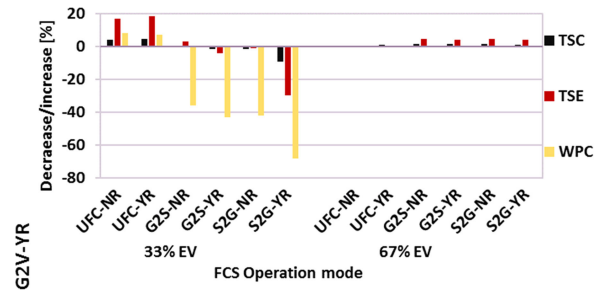

Fig. 6. FCS impact on EPS flexibility metrics G2V-YR.

fast charging modes without the capability of providing reserve (G2S-NR and S2G-NR) improves flexibility metrics; however, this is negligible compared to G2S-YR and S2G-YR modes. UFC-NR mode does not impact the metrics, while UFC-YR is the only mode negatively affecting EPS due to its increase in reserve requirements.

G2V-YR results (see Fig. 6) differ from those of USC-YR mode. When there is 33% share of EVs, UFC-NR and UFC-YR negatively impact flexibility metrics, as controllable slow charging does not provide enough flexibility to alleviate negative effects of uncontrollable fast charging. For higher EV share, i.e., 67% (meaning higher G2V-YR flexibility provision), fast charging impacts are completely mitigated. For 33% EV share, in all G2S and S2G modes, WPC is decreased. G2S-NR, G2S-YR, and S2G-NR have negligible effect on TSC and TSE, while S2G-YR provides far better results. For higher EV shares, all G2S and S2G modes act as TSC and TSE enhancers. A general conclusion can be made that unless fast chargers are coupled with ESS, they will have a negative impact on system operation, in terms of cost, emissions, and wind usage. Adding ESS to FCS can create additional benefits to the system operation by providing ancillary services, reducing the flexibility metrics.

## V. CONCLUSION

This paper presents a multiple service unit commitment model for combined SEV and FCS operation, giving insight into the operational flexibility issues of integrating EV, respecting all technical constraints of conventional and low carbon technologies. A detailed model of EV behavior and their impact on power system operation, both in passive and active/controllable regime, demonstrates how increasing number of FCS, as providers of higher EV user comfort, can have a negative impact on power system operation; increasing the total operational cost, emissions, and reducing the level of used renewable energy. Even in cases where a certain percentage of EV can fast charge during "optimal" time windows, the negative effects are clearly visible. Issues arising from EVs integration can be efficiently

mitigated and can turn into flexibility enhancement if adequate management plan is implemented. Uncoordinated fast and slow modes of charging will have severe negative effects on systems secure operation. If only controllable slow charging is enabled (for example at home), this could, to a significant level, mitigate negative effects of fast charging. ESS, as a part of FCS, can mitigate the negative effects caused by a large number of EVs being charged at FCS. Those effects are even more emphasized in case where a certain number of EVs are uncontrollably slow charged. In this paper, the role of storage is to act as a mediator between charging spot and power grid, also providing energy arbitrage and reserve services to the system operator. In general, FCS with integrated ESS can provide flexibility to power system by bidirectional power flow and by ancillary service provision. This paper revealed that ancillary services provision is more valuable as flexibility provider than the possibility of reinjecting the power back to grid.

## APPENDIX

### A. Decision Variables

$p_{t,i}^{g\_TP}$	Thermal units generation.
$p_{t,i}^{g\_HP}$	Hydro units generation.
$p_{t,i}^{g\_PS}, p_{t,i}^{p\_PS}$	Pump storage generation/pumping.
$p_t^{g\_WP}$	Wind power generation.
$p_{t,i}^{c\_EV}, p_{t,i}^{d\_EV}$	EV slow charging/discharging.
$p_{t,i}^{c\_FCS}, p_{t,i}^{d\_FCS}$	FCS charging/discharging.
$p_{t,i}^{f\_EV}$	EV fast charging.
$f_{t,i}^{up\_TP}, f_{t,i}^{dn\_TP}, r_{t,i}^{up\_TP}, r_{t,i}^{dn\_TP}$	Thermal units primary(f)/secondary(r) up/down reserve provision.
$f_{t,i}^{up\_HP}, f_{t,i}^{dn\_HP}, r_{t,i}^{up\_HP}, r_{t,i}^{dn\_HP}$	Hydro units primary(f)/secondary(r) up/down reserve provision.
$f_{t,i}^{up\_PS}, f_{t,i}^{dn\_PS}, r_{t,i}^{up\_PS}, r_{t,i}^{dn\_PS}$	Pump storage primary(f)/secondary(r) up/down reserve provision.
$f_{t,i}^{up\_EV}, f_{t,i}^{dn\_EV}, r_{t,i}^{up\_EV}, r_{t,i}^{dn\_EV}$	EV primary(f)/secondary(r) up/down reserve provision.
$f_{t,i}^{up\_EV}, f_{t,i}^{dn\_EV}, r_{t,i}^{up\_EV}, r_{t,i}^{dn\_EV}$	FCS primary(f)/secondary(r) up/down reserve provision.
$q_{t,i}^{up\_TP}$	Thermal units tertiary up reserve provision.
$s_{t,i}^{EV}$	Total energy in EV fleet of one EV type.
$s_{t,i}^{arr\_EV}$	Total energy in cluster of EV arriving to the grid.
$s_{t,i}^{leav\_EV}$	Total energy in a cluster of EV leaving the grid.
$s_{t,i}^{add\_FCS}$	Additional energy brought to EV fleet due to fast charging.
$p_t^{perf\_EV}$	Percentage of fast charging EV.
$x_{t,i}^{c\_EV}, x_{t,i}^{c\_FCS}$	Number of EV/FCS charging.
$p_t^{sh\_WP}$	Curtailed wind power.
$c_{t,i}^{TP}$	Total thermal power plant cost.
$c_{t,i}^{HP}$	Total HPP cost.
$c_{t,i}^{FCS}$	Energy conserved in FCS/ESS.

### B. Input Parameters

$T_{dur\_EV_i}^{dur}$	EV-type trip duration.
-----------------------	------------------------

$C_i^{0\_FCS}$	Initial SOC of FCS/ESS.
$C_i^{min\_FCS}, C_i^{max\_FCS}$	Minimum/maximum capacity of FCS/ESS.
$k_i^{loss\_FCS}$	Storage efficiency of FCS/ESS.
$P_t^d$	Power demand.
$F_t^{up}, F_t^{dn}$	Primary up reserve requirements.
$R_t^{up}, R_t^{dn}$	Primary down reserve requirements.
$Q_t^{up}$	Secondary up reserve requirements.
$P_t^{WP}$	Secondary down reserve requirements.
$R_t^{EV\_0,5h}, R_t^{EV\_4h}$	Tertiary up reserve requirements.
$R_t^{FCS\_0,5h}, R_t^{FCS\_4h}$	Potential wind power generation.
$\sigma_t^{sl(0,5h)\_EV}, \sigma_t^{sl(4h)\_EV}$	Secondary/tertiary reserve requirements increase caused by uncontrolled EV charging.
$\sigma_t^{sl(0,5h)\_FCS}, \sigma_t^{sl(4h)\_FCS}$	Secondary/tertiary reserve requirements increase caused by uncontrolled FCS charging.
$\sigma_t^{(0,5h)\_WP}, \sigma_t^{(4h)\_WP}$	EV USC charging standard deviation for secondary/tertiary reserve.
$N_{r,i}^{arr\_EV}, N_{t,i}^{g\_EV}, N_{t,i}^{leav\_EV}$	FCS uncontrolled charging standard deviation for secondary/tertiary reserve.
$N_{i\_TP}, N_{i\_HP}, N_{i\_PS}, N_{i\_EV}$	Wind power standard deviation for secondary/tertiary reserve.
$\sigma^d, C_i^{UCH\_EV}, \eta_i^{c\_EV}, \eta_i^{d\_EV}, \eta_i^{fc\_EV}, \eta_i^{c\_FCS}, \eta_i^{d\_FCS}$	# of EV arriving to the grid.
$S_i^{0\_EV}, S_i^{min\_EV}, S_i^{max\_EV}, S_i^{cons\_EV}$	# of EV connected to the grid.
$S_i^{minc\_EV}, P_{i\_max\_EV}^{fmax\_EV}, G_i^{EV}, G_i^{FCS}, P_{i\_min\_FCS}, P_{i\_max\_EV}, P_{i\_min\_FCS}, P_{i\_max\_FCS}, P_i^{perfmmin\_EV}, P_i^{perfmmax\_EV}$	# of EV leaving the grid.
	# of thermal technology types
	# of hydro technology types.
	# of pump storage technology types.
	# of electric vehicles types.
	Power demand standard deviation.
	Time required to recharge EV at full power.
	EV charging/discharging efficiency.
	EV fast charging efficiency.
	FCS charging/discharging efficiency.
	Initial energy conserved in EV fleet.
	The lowest SOC value of one EV.
	The highest SOC value of one EV.
	Energy conserved in one EV which arrives to the grid.
	The lowest allowed SOC in EV leaving the grid.
	Fast charging power maximum.
	Total number of EV per type.
	Total number of FCS per type.
	FCS charging (discharging) power minimum/maximum.
	EV charging (discharging) power min/max.
	Minimum/maximum percentage of fast charging

## REFERENCES

- [1] International Energy Agency, "2014 key world energy statistics," 2014.
- [2] B. C. Ummels, M. Gibescu, E. Pelgrum, W. L. Kling, and A. J. Brand, "Impacts of wind power on thermal generation unit commitment and dispatch," *IEEE Trans. Energy Convers.*, vol. 22, no. 1, pp. 44–51, Mar. 2007.



- [3] E. Banovac, M. Stojkov, and D. Kozak, "Designing a global energy policy model," *Energy*, vol. 170, no. 1, pp. 2–11, 2016.
- [4] P. D. Lund, J. Lindgren, J. Mikkola, and J. Salpakari, "Review of energy system flexibility measures to enable high levels of variable renewable electricity," *Renewable Sustain. Energy Rev.*, vol. 45, pp. 785–807, May 2015.
- [5] W. L. Kling, E. Pelgrum, and B. C. Ummels, "Integration of large-scale wind power and use of energy storage in the Netherlands' electricity supply," *IET Renewable Power Gener.*, vol. 2, no. 1, pp. 34–46, Mar. 2008.
- [6] H. Pandzic, Y. Wang, T. Qiu, Y. Dvorkin, and D. S. Kirschen, "Near-optimal method for siting and sizing of distributed storage in a transmission network," *IEEE Trans. Power Syst.*, vol. 30, no. 5, pp. 2288–2300, Sep. 2015.
- [7] K. Dietrich, J. M. Latorre, L. Olmos, and A. Ramos, "Demand response in an isolated system with high wind integration," *IEEE Trans. Power Syst.*, vol. 27, no. 1, pp. 20–29, Feb. 2012.
- [8] N. Holjevac, T. Capuder, and I. Kuzle, "Adaptive control for evaluation of flexibility benefits in microgrid systems," *Energy*, vol. 92, pp. 487–504, May 2015.
- [9] T. Capuder and P. Mancarella, "Techno-economic and environmental modelling and optimization of flexible distributed multi-generation options," *Energy*, vol. 71, pp. 516–533, Jul. 2014.
- [10] K. Schaber, F. Steinke, and T. Hamacher, "Transmission grid extensions for the integration of variable renewable energies in Europe: Who benefits where?" *Energy Policy*, vol. 43, pp. 123–135, Apr. 2012.
- [11] W. Liu, W. Hu, H. Lund, and Z. Chen, "Electric vehicles and large-scale integration of wind power – the case of inner mongolia in china," *Appl. Energy*, vol. 104, pp. 445–456, 2013.
- [12] A. Schuller, C. M. Flath, and S. Gottwalt, "Quantifying load flexibility of electric vehicles for renewable energy integration," *Appl. Energy*, vol. 151, pp. 335–344, Aug. 2015.
- [13] Z. Li, Q. Guo, H. Sun, Y. Wang, and S. Xin, "Emission-concerned wind-EV coordination on the transmission grid side with network constraints: Concept and case study," *IEEE Trans. Smart Grid*, vol. 4, no. 3, pp. 1692–1704, Sep. 2013.
- [14] M. Neaimeh *et al.*, "A probabilistic approach to combining smart meter and electric vehicle charging data to investigate distribution network impacts," *Appl. Energy*, vol. 157, pp. 688–698, 2015.
- [15] E. Veldman and R. A. Verzijlbergh, "Distribution grid impacts of smart electric vehicle charging from different perspectives," *IEEE Trans. Smart Grid*, vol. 6, no. 1, pp. 333–342, Jan. 2015.
- [16] E. Sortomme and M. A. El-Sharkawi, "Optimal scheduling of vehicle-to-grid energy and ancillary services," *IEEE Trans. Smart Grid*, vol. 3, no. 1, pp. 351–359, Mar. 2012.
- [17] R. J. Bessa and M. A. Matos, "Optimization models for EV aggregator participation in a manual reserve market," *IEEE Trans. Power Syst.*, vol. 28, no. 3, pp. 3085–3095, Aug. 2013.
- [18] R.-C. Leou, C.-L. Su, and J.-H. Teng, "Modelling and verifying the load behaviour of electric vehicle charging stations based on field measurements," *IET Gener., Transmiss. Distrib.*, vol. 9, no. 11, pp. 1112–1119, 2015.
- [19] G. Wang, Z. Xu, F. Wen, and K. P. Wong, "Traffic-constrained multi-objective planning of electric-vehicle charging stations," *IEEE Trans. Power Del.*, vol. 28, no. 4, pp. 2363–2372, Oct. 2013.
- [20] A. Y. S. Lam, Y.-W. Leung, and X. Chu, "Electric vehicle charging station placement: Formulation, complexity, and solutions," *IEEE Trans. Smart Grid*, vol. 5, no. 6, pp. 2846–2856, Nov. 2014.
- [21] S. Guo and H. Zhao, "Optimal site selection of electric vehicle charging station by using fuzzy TOPSIS based on sustainability perspective," *Appl. Energy*, vol. 158, pp. 390–402, Nov. 2015.
- [22] W. Lee, L. Xiang, S. Member, R. Schober, V. W. S. Wong, and S. Member, "Electric vehicles charging stations with renewable power generators: A game theoretical analysis," *IEEE Trans. Smart Grid*, vol. 6, no. 2, pp. 608–617, Mar. 2015.
- [23] M. R. Sarker, H. Pandzic, and M. A. Ortega-Vazquez, "Optimal operation and services scheduling for an electric vehicle battery swapping station," *IEEE Trans. Power Syst.*, vol. 30, no. 2, pp. 901–910, Mar. 2015.
- [24] D. Dallinger, D. Krampe, and M. Wietschel, "Vehicle-to-grid regulation reserves based on a dynamic simulation of mobility behavior," *IEEE Trans. Smart Grid*, vol. 2, no. 2, pp. 302–313, Jun. 2011.
- [25] A. Khazali and M. Kalantar, "A stochastic-probabilistic energy and reserve market clearing scheme for smart power systems with plug-in electrical vehicles," *Energy Convers. Manage.*, vol. 96, pp. 242–257, 2015.
- [26] M. Shafie-khah, M. P. Moghaddam, M. K. Sheikh-El-Eslami, and J. P. S. Catalão, "Optimised performance of a plug-in electric vehicle aggregator in energy and reserve markets," *Energy Convers. Manage.*, vol. 97, pp. 393–408, 2015.
- [27] J. Zhong *et al.*, "Coordinated control for large-scale EV charging facilities and energy storage devices participating in frequency regulation," *Appl. Energy*, vol. 123, pp. 253–262, 2014.
- [28] S. Izadkhast, P. Garcia-Gonzalez, and P. Frias, "An aggregate model of plug-in electric vehicles for primary frequency control," *IEEE Trans. Power Syst.*, vol. 30, no. 3, pp. 1475–1482, May 2015.
- [29] J. Meng, Y. Mu, H. Jia, J. Wu, X. Yu, and B. Qu, "Dynamic frequency response from electric vehicles considering travelling behavior in the Great Britain power system," *Appl. Energy*, vol. 162, pp. 966–979, 2016.
- [30] W. Leterme, F. Ruelens, B. Claessens, and R. Belmans, "A flexible stochastic optimization method for wind power balancing with PHEVs," *IEEE Trans. Smart Grid*, vol. 5, no. 3, pp. 1238–1245, May 2014.
- [31] L. Jian, Y. Zheng, X. Xiao, and C. C. Chan, "Optimal scheduling for vehicle-to-grid operation with stochastic connection of plug-in electric vehicles to smart grid," *Appl. Energy*, vol. 146, pp. 150–161, May 2015.
- [32] R. Faria, P. Moura, J. Delgado, and A. T. de Almeida, "Managing the charging of electrical vehicles: Impacts on the electrical grid and on the environment," *IEEE Intell. Transp. Syst. Mag.*, vol. 6, no. 3, pp. 54–65, Fall 2014.
- [33] M. Alizadeh, A. Scaglione, J. Davies, and K. S. Kurani, "A scalable stochastic model for the electricity demand of electric and plug-in hybrid vehicles," *IEEE Trans. Smart Grid*, vol. 5, no. 2, pp. 848–860, Mar. 2014.
- [34] C. Liu, J. Wang, A. Botterud, Y. Zhou, and A. Vyas, "Assessment of Impacts of PHEV charging patterns on wind-thermal scheduling by stochastic unit commitment," *IEEE Trans. Smart Grid*, vol. 3, no. 2, pp. 675–683, Jun. 2012.
- [35] M. E. Khodayar, L. Wu, and Z. Li, "Electric vehicle mobility in transmission-constrained hourly power generation scheduling," *IEEE Trans. Smart Grid*, vol. 4, no. 2, pp. 779–788, Jun. 2013.
- [36] A. Shortt and M. O'Malley, "Quantifying the long-term impact of electric vehicles on the generation portfolio," *IEEE Trans. Smart Grid*, vol. 5, no. 1, pp. 71–83, Jan. 2014.
- [37] P. J. Ramirez, D. Papadaskalopoulos, and G. Strbac, "Co-optimization of generation expansion planning and electric vehicles flexibility," *IEEE Trans. Smart Grid*, vol. 7, no. 3, pp. 1609–1619, May 2016.
- [38] I. Pavić, T. Capuder, and I. Kuzle, "Value of flexible electric vehicles in providing spinning reserve services," *Appl. Energy*, vol. 157, pp. 60–74, Nov. 2015.
- [39] I. Pavić, T. Capuder, and I. Kuzle, "Low carbon technologies as providers of operational flexibility in future power systems," *Appl. Energy*, vol. 168, pp. 724–738, Apr. 2016.
- [40] M. A. Ortega-Vazquez, D. S. Kirschen, and Y. Dvorkin, "Wind generation as a reserve provider," *IET Gener., Transmiss. Distrib.*, vol. 9, no. 8, pp. 779–787, May 2015.
- [41] V. Silva, "Value of flexibility in systems with large wind penetration," Ph.D. dissertation, Dept. Elect. Electron. Eng., Univ. London, London, U.K., 2010.
- [42] M. Carrion and J. M. Arroyo, "A computationally efficient mixed-integer linear formulation for the thermal unit commitment problem," *IEEE Trans. Power Syst.*, vol. 21, no. 3, pp. 1371–1378, Aug. 2006.
- [43] L. Zhang, T. Capuder, and P. Mancarella, "Unified unit commitment formulation and fast multi-service LP model for flexibility evaluation in sustainable power systems," *IEEE Trans. Sustain. Energy*, vol. 7, no. 2, pp. 658–671, Apr. 2016.
- [44] M. Aunedi, "Value of flexible demand-side technologies in future low-carbon systems," Ph.D. dissertation, Dept. Elect. Electron. Eng., Imperial College London, London, U.K., 2013.
- [45] R. Van Haaren, "Assessment of electric cars' range requirements and usage patterns based on driving behavior recorded in the National Household Travel Survey of 2009," Columbia Univ., New York, NY, USA, 2011.
- [46] G. Pasaoglu, D. Fiorello, L. Zani, A. Martino, A. Zubaryeva, and C. Thiel, "Projections for electric vehicle load profiles in Europe based on travel survey data contact information," Eur. Commission Joint Res. Centre Inst. for Energy and Transport, Luxembourg, 2013.
- [47] Dept. Transport, "Vehicle licensing statistics: Quarter 3 (Jul–Sep) 2014," 2014.

Authors' photographs and biographies not available at the time of publication.



### **Publication 4**

I. Pavić, H. Pandžić, and T. Capuder, “Electric vehicle based smart e-mobility system – Definition and comparison to the existing concept,” *Applied Energy*, vol. 272, p. 115 153, Aug. 2020, ISSN: 03062619. DOI: 10.1016/j.apenergy.2020.115153

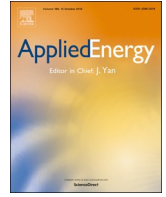

# Electric vehicle based smart e-mobility system – Definition and comparison to the existing concept



Ivan Pavić\*, Hrvoje Pandžić, Tomislav Capuder

University of Zagreb, Faculty of Electrical Engineering and Computing, Zagreb HR-10000, Croatia

## HIGHLIGHTS

- Control authority in smart e-mobility is usually on the side of charging stations.
- Electric vehicle based concept is an alternative where vehicles control charging.
- In a proposed concept charging stations are merely an enabling infrastructure.
- Electric vehicle based system yields higher revenues for the vehicle owners.

## ARTICLE INFO

### Keywords:

Electric vehicles  
Charging stations  
Aggregator  
Electric vehicle aggregator  
Electricity market

## ABSTRACT

The existing models designed to reap the benefits of electric vehicles' flexibility in the literature almost exclusively identify charging stations as active players exploiting this flexibility. Such stations are seen as static loads able to provide flexibility only when electric vehicles are connected to them. This standpoint, however, suffers from two major issues. First, the charging stations need to anticipate important parameters of the incoming vehicles, e.g. time of arrival/departure, state-of-energy at arrival/departure. Second, it interacts with vehicles only when connected to a specific charging station, thus overlooking the arbitrage opportunities when they are connected to other stations. This conventional way of addressing the electric vehicles is referred to as charging station-based e-mobility system. A new viewpoint is presented in this paper, where electric vehicles are observed as dynamic movable storage that can provide flexibility at any charging station. The paper defines both the existing system, where the flexibility is viewed from the standpoint of charging stations, and the proposed one, where the flexibility is viewed from the vehicles' standpoint. The both concepts are mathematically formulated as linear optimization programs and run over a simple case study to numerically evaluate the differences. Each of the four issues identified are individually examined and omission of corresponding constraints is analysed and quantified. The main result is that the proposed system yields better results for the vehicle owners.

## 1. Introduction

Much focus has been given lately to the decarbonization of the electricity production, however a greater challenge might be doing the same with the heating and transportation sector. The transition from conventional vehicles to low carbon emission ones is moving slower than anticipated, despite that its importance is highlighted in all relevant policy documents [1]. The solutions for changing transportation habits and preferences of end-users [2] require an integrated approach, especially in designing models for end-users and encouraging them to make a quicker transition to electrified transport, as designed by the relevant regulatory goals [3]. This means being aware of technical, economic and social constraints when creating models to make

electrification of the transport an alternative new flexibility source. If electric vehicles (EVs) are charged uncontrollably [4], i.e. charging at maximum power until fully charged, power system's hunger for flexibility increases, calling for additional investments in peaking units and grid infrastructure upgrades. On the other hand, if EVs are charged in a controllable manner [5], they resemble features of both demand response and energy storage. Shifting their charging times represents the aspect of demand response. This is often referred to as Grid-to-Vehicle (G2V) mode, which requires unidirectional controllable chargers [6]. A possibility to discharge a part of the surplus energy when not needed for motion, often referred to as Vehicle-to-Grid (V2G) mode, corresponds to the energy storage aspect of EVs and requires bidirectional controllable chargers [7,8]. Detailed overviews of EV charging modes are available

\* Corresponding author.

E-mail addresses: [ivan.pavic@fer.hr](mailto:ivan.pavic@fer.hr) (I. Pavić), [hrvoje.pandzic@fer.hr](mailto:hrvoje.pandzic@fer.hr) (H. Pandžić), [tomislav.capuder@fer.hr](mailto:tomislav.capuder@fer.hr) (T. Capuder).

<https://doi.org/10.1016/j.apenergy.2020.115153>

Received 10 February 2020; Received in revised form 1 May 2020; Accepted 5 May 2020

0306-2619/© 2020 The Authors. Published by Elsevier Ltd. This is an open access article under the CC BY-NC-ND license (<http://creativecommons.org/licenses/by-nc-nd/4.0/>).



Fig. 1. Illustrative example composed of three EVs and three CSs - general overview.

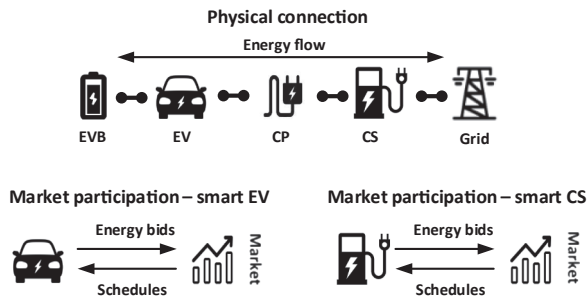

Fig. 2. Physical connection and market participation of EV-based and CS-based smart e-mobility models.

in [9,10].

This paper proposes a new concept of using the EV flexibility more efficiently in a world with a multitude of new data streams relying on information-communication technologies in vehicles and without any loss of comfort for EV drivers. We argue that the state-of-the-art literature, research projects and e-mobility sector currently conceive the smart e-mobility in a way which leads to an underutilization of the EV flexibility and to insufficient financial returns. The usual understanding of smart e-mobility is that Charging Stations (CSs) use EVs to provide flexibility to the power system (we define this as the CS-based concept), whereas this paper challenges this approach and reverses the roles by identifying EVs themselves as smart players that provide flexibility and the CSs as merely an enabling infrastructure (we refer to this as the EV-based concept).

The *smart e-mobility* term used in this paper refers to an advanced multisector system where the main actors are: EVs, CSs, Electric Vehicle Aggregators (EVAs), power grid and electricity market operators. Merchant actors within this ecosystem have at their disposal smart EV charging and discharging options to provide flexibility to the power system and in return receive monetary reward. This paper analyzes a basic illustrative example with three EVs and three CSs. The purpose of the example is to highlight certain issues in the state-of-the-art, after which we define a new mathematical model and demonstrate how the issues of the current state-of-the-art are eliminated using our model through a detailed case study.

This paper contributes to the body of knowledge in the field of EV aggregation by providing the following:

1. a design and a formulation of a novel EVA model tracking the EVs during their trips, thus capturing all relevant trip and battery information,
2. a systematic and rigorous comparative assessment of the CS-based and EV-based models,
3. a demonstration that aggregate EV models without relevant features, such as power levels and grid tariffs, result in incorrect conclusions regarding the cost of EV charging.

## 2. Illustrative example

### 2.1. Assumptions and description

An illustrative example presented in Figs. 1–3 compares the current smart e-mobility CS-based model with the proposed EV-based concept. Several simplifications and assumptions are made to keep this example concise. We observe three EVs and three CSs (Fig. 1) and their behavior through a 24-h period with 1-h time resolution. Each EV can be charged at different CSs and each driving period, i.e. period when EV is not connected to any CS, lasts one hour. Each EV has one Battery (EVB) and one On-Board Charger (OBC), while each CS encompasses three Charging Points (CPs), meaning it can serve all three EVs at a time. All three CPs within a CS are AC and have chargers of same power capacity.

Let us assume that both EVs and CSs can individually participate in the wholesale electricity market,<sup>1</sup> namely the day-ahead market, and that their objective is to minimize the purchasing costs of electricity for mobility purposes and/or to maximize revenue through energy arbitrage.

A smart e-mobility system can therefore be conceived as an EV-based or a CS-based, as illustrated in Fig. 2. In the former model, the EVs are the smart entities negotiating market strategy while the CSs are merely an infrastructure with their technical constraints (CP power capacity) and economic parameters (CS utilization fee). The latter model observes the same entities, but from an opposite standpoint. The CSs are the smart entities negotiating market strategy, while the EVs only impose technical constraints (OBC power capacity) and economic charges (battery utilization fee). The CSs must pay a fee to use the EVs' physical equipment (battery) and the energy stored within the EVBs when performing arbitrage (V2G mode). On the other hand, they receive payments by the EVs for the energy they charge for driving purposes. Currently, the roads are populated with both hybrid and full EVs. Hybrid EVs can be seen as a part of the bridging process toward the full transportation electrification. Our focus is on future scenarios where electrification is already in its final steps and where full EVs are a dominant technology. Therefore, we do not explicitly model the hybrid EVs in this paper.

### 2.2. EV-based vs. CS-based smart e-mobility model

We use the graphs in Fig. 3 to describe the differences between the EV-based and the CS-based smart e-mobility models. The graphs to the left show charging profiles of the three EVs, while the ones to the right show charging profiles of the three CSs. All graphs are created from the same data, but observed from different viewpoints: graphs to the left are relevant for the EV-based, while the ones to the right are relevant for the CS-based smart e-mobility model.

EVs in Fig. 3 are shown in different colors: EV1 – turquoise, EV2 – orange, and EV3 – purple. Their respective OBC maximum powers (OBC LIM) are marked with straight lines: EV1 – low-power OBC (4 kW), EV2 – medium-power OBC (8 kW), and EV3 – high-power OBC (12 kW). The EVs can charge at three CS types: CS1 is a home charger (4 kW) – green, CS2 is charger at work (8 kW) – blue, and CS3 is charger at a shopping mall (12 kW) – red. EVs have different driving profiles. EV1 has a *home-work-home* profile: it is connected to CS1 from midnight to 07:00, drives to CS2 where it stays from 08:00 to 16:00, and drives back to CS1, where it is connected from 17:00 to midnight. Charging profile of EV2 is *home-mall-home*, while EV3's profile is *home-work-mall-home*. Each charging period is colored according to the corresponding CS.

The CS charging curves are composed of the charging curves of the EVs connected to it. For example, the graph for CS1 (upper-right in

<sup>1</sup> Currently this is done through aggregators due to energy bid thresholds in most markets.



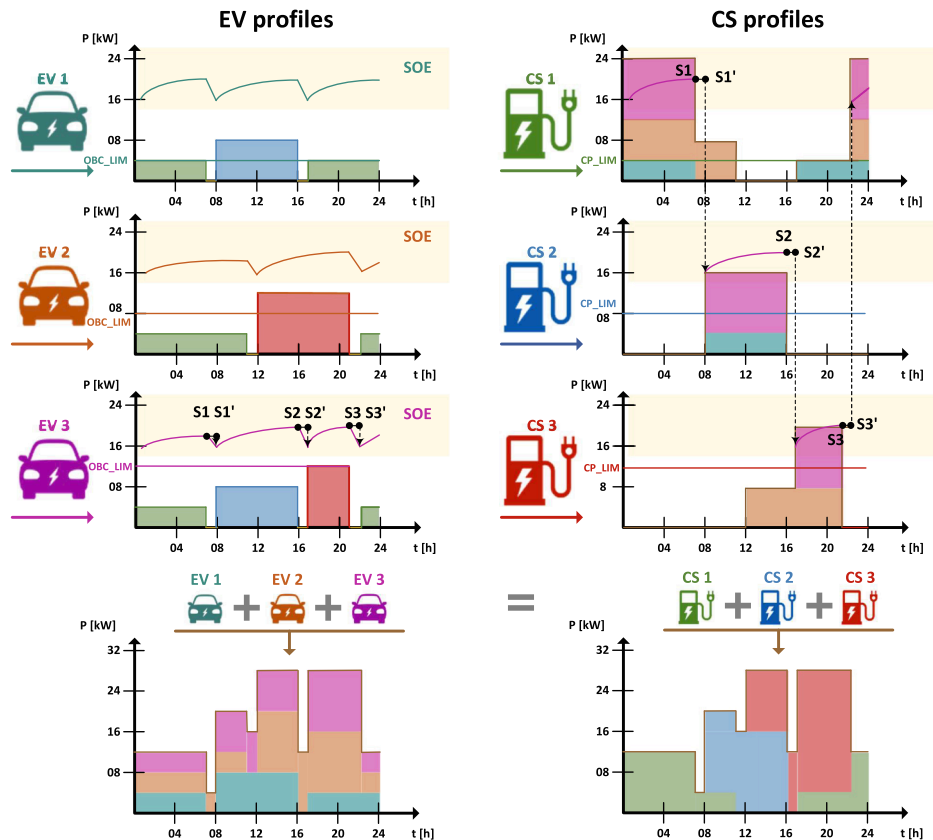

Fig. 3. Illustrative example - daily curves for three EVs and three CSs; left figures - EV view on charging profiles, right figures - CS view on charging profiles.

Fig. 3) shows that all three EVs are connected to it from 00:00 to 07:00. The power required at CS1 during that time is the sum of the OBC powers of the EVs using it. EV2 (orange) is staying longer at CS1 (until 11:00), while EV1 (turquoise) comes back home earlier than others (at 17:00). Since EV1 and EV3 are at work during the morning and midday hours, CS2 has two connected EVs from 08:00 to 16:00 (turquoise EV1 and purple EV3), and no connected EVs in other hours. EV2 goes to a shopping mall, where it charges at CS3 from 12:00 to 21:00, while EV3 goes to the mall after work from 17:00 to 21:00 (third graph on the right-hand side). The areas in the graphs to the right correspond to stacked OBC powers, while the maximum CP power limits are indicated with fixed straight lines. In instances where  $CP\_LIM$  is lower than  $OBC\_LIM$ , the CP is the limiting factor for charging power.

The lower graphs in Fig. 3 are aggregate curves based on the EVs' behavior (on the left) and the CSs' behavior (on the right). The colors display which EV (on the left) or CS (on the right) contributes to the aggregated behavior at a specific period of time. The outline curve is the same in the left and the right graphs, meaning that if there is only one central aggregation entity that oversees all EVs and CSs, it does not matter whether it is defined as an EV- or a CS-based. However, it does matter when multiple aggregators enter the market. Interesting research concerning EV and CS measurements data sets can be found in [11] where they observe similar issue of EV and CS viewpoints.

The areas with the yellow background in the graphs in Fig. 3 show the EV state of energy (SOE) throughout the day. In graphs to the left, each SOE curve corresponds to the corresponding EV, while in graphs to the right only the SOE curve of EV3 is displayed for simplicity.

Both concepts base their predictions for available power and energy on the accurate SOE estimations. Those estimations itself could be highly uncertain due to differences in chemical structure of the cells and due to different algorithms used for the estimations [12,13].

From the ecological perspective, EV batteries effect greenhouse emission at both the production and the utilization stages. The

production stage contributes to around 150–200 kg  $CO_2$ -eq/kWh according to [14], where most of production-stage emissions are the result of battery manufacturing and material processing. Manufacturing and processing are mostly nonflexible, meaning that the energy mix of the power system defines the exact level of emissions. A solution to lower the emission at the production stage is therefore decarbonization of the power system. The concepts of smart EV charging does not directly lower the production emissions, but they do foster the power system decarbonization. In other words, the EV-based e-mobility system could significantly increase the share of renewable power in power systems.

Research carried out in [15] concludes that the emissions related to EVs during the utilization phase are by far the lowest in high-renewable energy case studies. European Energy Agency confirmed that decrease of emissions from transport electrification is significantly higher than the increase in emissions due to higher electricity production to support transportation electrification [16]. In this paper we assume that electricity price follows the renewable generation, i.e. low price indicates abundance of renewable generation and vice versa. Therefore, the EV scheduling by price minimization also tends to maximize renewable generation utilization. However this is not always the case. Thus, if an EV user wants to schedule its EV directly to maximize renewable generation, the objective function should be reformulated to consider the amount of renewable generation in the system. In general, the proposed EVBA concept allows decarbonization due to its better adaptability to changes in the power system, resulting in reduced system operator's flexibility needs.

### 2.3. Data transfer

Different data forms must be exchanged between the EVs and the CSs, which is essential for proper smart e-mobility operation in both the EV- and CS-based system. In the EV-based system the CS data must be

sent to EVs, while in the CS-based system the EV data must be sent to CSs.

Required EV data are:

1. technical data – parameters such as OBC power levels, battery capacity, etc.,
2. infrastructure cost – expenses arising from EV usage apart from mobility reasons, such as V2G battery degradation,
3. preferences – EV users' desires related to charging, such as minimum SOE under which an EV does not offer flexibility, targeted SOE at some point in time, etc.,
4. behaviour – historic driving/parking data which serve as a base for future EV behaviour forecasts.

Required CS data are:

1. technical data – parameters such as CP connector type and CP power levels,
2. infrastructure cost – expenses arising from the CS usage for any kind of charging and discharging, e.g. CS operation and maintenance cost, CS investment return, and grid fees.

### 3. Issues and proposed solution

In the CS-based smart e-mobility system the CSs submit their individual bids in the market. Each of them runs their own optimization algorithm based on their own predictions. However, this results in the issues individually elaborated below, each followed by a proposed solution using the EV-based concept.

#### 3.1. Issue 1 – insufficient information on EVs' behavior at other CSs

##### 3.1.1. CS-based issue

The first issue is that a CS only tracks the EVs' SOE in the periods when they are connected to it. From the mathematical standpoint, power to be charged/discharged and the SOE while the EVs are either parked at other premises or driving are unknown and included in the model as stochastic parameters. Only when EVs are connected to this CS those values become controllable variables. If observing the SOE curve of EV3 in Fig. 3, it is broken down into several segments (at points S1–S3), where each CS can see only one part of it but not the entire daily curve. This is a major drawback since the values of the (dis) charging variables should come directly from forecasting the four main attributes of each EV:

1. arrival time of vehicle  $v$  ( $t_v^{ARR}$ ),
2. SOE at arrival ( $SOE_v^{ARR}$ ),
3. departure time ( $t_v^{DEP}$ ),
4. required SOE at departure ( $SOE_v^{DEP}$ ).

For the CSs in the presented example, the following stands for EV3:

- CS1 forecasts  $t_v^{DEP}$  and  $SOE_{v,cp1}^{DEP}$  at S1 and  $t_v^{ARR}$  and at S3',
- CS2 forecasts  $t_v^{ARR}$  and  $SOE_{v,cp2}^{ARR}$  at S1' and  $t_v^{DEP}$  and  $SOE_{v,cp2}^{DEP}$  at S2,
- CS3 forecasts  $t_v^{ARR}$  and  $SOE_{v,cp3}^{ARR}$  at S2' and  $t_v^{DEP}$  and  $SOE_{v,cp3}^{DEP}$  at S3.

The CSs must do the same for all EVs coming to charge. Mathematically, this is represented as follows:

$$\text{if } t \in \Omega_{v,cp}^{T_{\text{parked\_at\_observed\_CS}}} \\ soe_{v,t}^{EV} = soe_{v,t-1}^{EV} + e_{v,t}^{SCH} \cdot \eta^{SCH} - e_{v,t}^{DCH} / \eta^{DCH}, \quad (1)$$

$$\text{else-if } t = t_{v,cp}^{ARR} \\ soe_{v,t}^{EV} = SOE_{v,cp}^{ARR}, \quad (2)$$

$$\text{else-if } t = t_{v,cp}^{DEP} \\ soe_{v,t}^{EV} \geq SOE_{v,cp}^{DEP}, \quad (3)$$

$$\text{else } t \in \Omega_{v,cp}^{T_{\text{driving\_or\_parked\_at\_other\_CS}}} \\ soe_{v,t}^{EV} \text{ unconstrained } \forall v, t. \quad (4)$$

The first equation tracks an EVB while the EV is parked at the observed CS ( $\Omega_{v,cp}$  is a set of EVs  $v$  at charging point  $cp$  at time  $t$ ), with variables  $soe_{v,t}^{EV}$ ,  $e_{v,t}^{SCH}$  and  $e_{v,t}^{DCH}$  denoting the EV's SOE, energy charged and discharged, respectively, and  $\eta^{SCH}$  and  $\eta^{DCH}$  the corresponding efficiencies. Eqs. (2) and (3) set the  $soe_{v,t}^{EV}$  at arrival/departure based on the SOE forecasts or requirements. The periods when an EV is driving or parked at other CSs are not explicitly modeled and its behavior during these periods can only be considered through the forecasted values of unknown parameters, eq. (4).

The questions that inspired this research were: How would each of the CSs forecast the four uncertain values (arrival time, SOE at arrival, departure time and required SOE at departure) for all the EVs with sufficient accuracy? How would they anticipate the EVs' behavior while driving and especially while at other CSs? One option is that each EV sends its data to all the CSs where it could potentially park and charge. Another option is that each CS sends its own forecasts for each EV to all CSs in surroundings, i.e. all the CSs should optimize their portfolio in a joint optimization or using separate optimizations with coupling SOE constraints. On top of the issue of global optimality of such approach, the amount of data to be transmitted becomes critical and data security issues could easily render such model inapplicable.

#### 3.1.2. EV-based solution

In the EV-based smart e-mobility system, the three EVs in Fig. 3 submit their individual bids to the market operator. Each of them runs its own independent optimization algorithm based on own predictions. Contrary to the CS-based system, each EV knows its behavior (SOE curve) throughout the day wherever it is. From the mathematical standpoint, power to be (dis) charged and the SOE is always known to the EV. If the SOE curve of EV3 in Fig. 3 is observed, EV3 sees it as a continuous line without interruptions at points S1–S3, while the CSs see only their portion of this curve. The EV-based model can thus be mathematically represented as follows:

$$soe_{v,t}^{EV} \\ = soe_{v,t-1}^{EV} + e_{v,t}^{SCH} \cdot \eta^{SCH} - e_{v,t}^{DCH} / \eta^{DCH} - E_{v,t}^{RUN} / \eta^{RUN} + e_{v,t}^{FCH} \cdot \eta^{FCH} \quad \forall \\ v, t; \quad (5)$$

It sets the EVs' SOE considering the SOE from the previous time step, charging at a slow CS (SCH), energy discharged in V2G mode (DCH), discharged for driving purposes (RUN), and energy charged at fast charging stations (FCH). Compared to Eqs. (1)–(4) in the CS-based system, this model observes and controls all variables at all time periods. The forecasting effort is drastically reduced and simplified since the EV predicts its own behavior, while in the CS-based system each CS must predict behavior of a multitude of EVs. There is no need for the EV-to-CS communication nor for additional CS-to-CS communication. Each EV keeps its driving/parking information and its technical data to itself and does not send any data to other entities. The complexity of data flow is reduced, while its security is increased as compared to the CS-based model.

#### 3.2. Issue 2 – inability to transfer flexibility between CSs

##### 3.2.1. CS-based issue

The second issue in the CS-based system relates to daily human activities and the way the CSs are usually organized. In our example, CS1 is a home charger and has access to the EVs mostly during the night. On the other hand, CS2 has EVs connected to it only during

daytime, while the EVs are at CS3 mostly during the evening periods. When performing energy arbitrage, the energy should be shifted from peak to low-price periods. Usually, the prices are lower during the night (when the consumption is low) and midday (when PV generation is high and load is at its local minimum), while the peak prices occur in the morning and evening (when PV generation is low and consumption high). The CSs aiming to perform energy arbitrage with EVs should thus roughly follow the sequence: night→charging, morning→discharging, midday→charging, evening→discharging. CS1 has only one EV connected to it in the morning and the evening so it cannot discharge all the EVs at peak periods. At midday it does not have any EVs connected to it and thus cannot recharge them. CS2 cannot transfer energy from night to evening periods because it does not have any EVs connected to it in the evening, but can discharge the EVs in the morning and recharge them at midday. However, to have enough energy to discharge EVs in the morning it must communicate with CS1 and request additional charging (more than necessary for mobility). CS3 can discharge EVs in the evening, but it needs to communicate the additional energy with CS2.

### 3.2.2. EV-based solution

The EV-based concept follows the EVs throughout the day. EV3 in Fig. 3 can provide optimal charge–discharge sequence following the typical daily price curve elaborated above. It can charge during the night at CS1 and discharge in the morning at CS2, where it can also recharge around midday. Then, it can discharge in the evening at CS3 and start charging at CS1 late in the evening. In the EV-based system, the EV flexibility can thus be fully exploited without the need for CS-to-CS communication. To summarize, the proposed EV-based concept results in higher savings, no privacy issues and lower communication burden.

## 3.3. Issue 3 – insufficient power constraints

### 3.3.1. CS-based issue

Throughout the day, EVs with their own OBC power capacities park at CSs with various power capacities. This issue is illustrated in the graphs to the right in Fig. 3, where each CP installed power capacity is shown with a fixed value, CP\_LIM, while the EVs' OBC power constraints are shown as stacked colored areas. If the OBC power constraints are omitted, the CSs could end up scheduling higher power than technically possible to deliver, e.g. EV1 at CS2. On the other hand, if the OBC power constraint is higher than the CP power constraint, the CP constraint is binding and does not affect the EV scheduling, e.g. EV2 at CS1.

Such events can cause differences between the scheduled and delivered energy and lead to additional balancing costs. The OBC installed power is an additional parameter that all EVs must communicate to the CSs or CSs must anticipate, which can lead to errors. Furthermore, this EV-to-CS communication is highly inconvenient due to large amount of dynamic data as well as security issues.

### 3.3.2. EV-based solution

EVs change their location during the day. In our example EV1 and EV2 park at two, while EV3 parks at three different locations. Since CSs have different installed charging powers, the EVs must anticipate the installed power of the CSs where they park. This is illustrated in Fig. 3 on graphs to the left, where each EV's OBC installed power (OBC\_LIM) is shown as a fixed value, while the CSs' capacities vary through the day (visualized as stacked colored areas). If the CS power constraint is omitted, the EVs whose OBC is of higher power than the CS's maximum power could schedule more charging power than possible in reality, e.g. EV2 during night/morning parked at CS1.

As in the CS-based concept, both the OBC and CS maximum charging power constraints need to be included in the optimization model. However, most CSs publicly publish their chargers' technical

parameters, such as connector type and installed power, and EVs can easily download the required data. The EV-to-CS communication is again avoided making the EV-based system easier to implement than the CS-based system.

## 3.4. Issue 4 – incomplete costs

### 3.4.1. CS-based issue

Each EV must pay energy cost for its basic mobility charging in the electricity market (through its CS supplier). Apart from energy expenditures, each load must pay a grid fee (upper part of Fig. 2). CSs are connected to the low voltage distribution grid and the grid fees account for a significant share in their total costs transferred to the EVs. To properly address the cost of EV charging, grid fees must be taken into account.<sup>2</sup>

Apart from energy cost and grid fees, there is a cost associated with remuneration between the EVs and the CSs. When it comes to basic mobility charging, EVs pay fees to the CSs to recover the operation and maintenance costs, as well as the investment. However, when CSs use EVBs for energy arbitrage or other actions beside basic mobility charging, they should pay a fee to the EVs for using their battery since increased battery cycling causes faster degradation. In the CS-based system, a CS must obtain data from EVs on their infrastructure (battery) costs. Again, the EVs must send their private data to all relevant CSs.

### 3.4.2. EV-based solution

In the EV-based system, EVs obtain data on CS infrastructure costs and grid fees. Unlike the EVs, the CSs are public and already publish their prices online to attract EVs. In the proposed EV-based system, EVs must pay a fee to CSs whenever they use them for energy arbitrage and/or basic mobility charging. The EV-to-CS communication is not necessary as the relevant CS data are available online.

## 4. Current state-of-the-art, industry practices and proposed concept

### 4.1. Literature review

State-of-the-art literature on smart e-mobility scheduling can be divided into several research approaches. Table 1 summarizes the literature considering three topics (smart home/microgrids, EV aggregators, smart parking lots/charging stations) and the way they tackle the four issues detected in Section 3. Under *Issue 1* we add an intermediate step between the CS-based and EV-based concepts for papers using equations similar to (5), but not specifying chargers or considering only residential chargers.

#### 4.1.1. Smart homes/microgrids

Smart home algorithms often include EVs as one of the demand response appliances that help minimize the total home electricity bill [17–21,24,27,28]. Papers [17,27] seek to optimize a smart home comprising of demand response devices, PVs, energy storage and EVs to cut down the peak power and electricity cost. Paper [18] consists of two parts: EV charging scheduling algorithm for smart homes/buildings and implementation of a prototype application for home/building EMS. In [19] a detailed structure of a household user capable of energy transactions between consumers and load-serving entities is presented. Authors in [20] propose a heuristic method that suggests most suitable charging/discharging instances for an EV battery in a time-of-day regime. Paper [21] investigates the optimal sizing of PV, wind turbine, and storage in a smart home with EV. In [24] the authors presented a model for participation of sub-aggregators in the aggregation of EVs in

<sup>2</sup> Generation facilities mostly do not pay the grid fees. In case of V2G discharging, such fees could have a major effect on its financial profitability.

**Table 1**Categorization of research papers related to *Issues 1–4* (comm. – commercial; ch. – charging; inf. – infrastructure; deg. – degradation).

Literature type	<i>Issue 1</i> – insufficient information on EVs' behavior at other CSs			<i>Issue 2</i> – inability to transfer flexibility between CSs		
	CS-based	EV-based with only 1 CS	EV-based	Households	Work/comm. ch. station	Multiple
hline Smart homes/ microgrids	[17–26]	[27–29]	–	[17–23,27,28,24–26]	–	[29]
EV aggregators	[30–41]	[42,43]	–	[30–34,36,38,42,43],	[39]	[35,37,40,41]
Parking lots/ ch. stations	[44–58]	–	–	[50]	[44–49,51–58]	–
Proposed concept	–	–	✓	–	–	✓
Literature type	<i>Issue 3</i> – insufficient power constraints			<i>Issue 4</i> – incomplete costs		
	Fixed	CP or OBC only	Both CP and OBC	No grid/inf./deg. cost	With grid fee/ inf. cost	With deg. cost
Smart homes/ microgrids	[17–22,27–29,24–26]	[23]	–	[17,18,20–23,28,29,24–26]	[19]	[27]
EV aggregators	[30,32–34,36–43]	[31,35]	–	[30–35,37,38,43]	[39]	[36,40,42,41]
Parking lots/ ch. stations	[44–46,48–52,54–56],	–	[47]	[44–46,48–56],	[47]	[53,57,51]
Proposed concept	–	–	✓	–	✓/✓	✓

a residential complex. In [28] authors propose an EV charge/discharge management framework for the effective utilization of PV output through coordination of home and grid energy management systems. All these algorithms observe only a single EV at a single location, which directly makes them susceptible to *Issues 1 & 2*.

EVs and smart homes can also be grouped under a microgrid where EVs act as flexibility providers [22,23]. In future interconnected smart grid, EVs will be able to interact both with the smart communities (local microgrids) and the central grid to offer their services [29]. The smart building could also be considered a microgrid (including vehicle-to-building control strategy to dispatch the EVs as a flexible resource) where the objective function is minimization of microgrids/buildings electricity costs [25]. Optimization of a microgrid could also be made in a multi-objective manner where microgrid (containing EVs) is optimized regarding cost-economy, operation-efficiency and system-security [26]. Table 1 shows that papers related to home/microgrids are mostly CS-based and focused on home-chargers with fixed power levels (*Issue 3*) and consider only energy prices (*Issue 4*). Exception to the standard CS-based models are papers [27,28], which model the EV behavior throughout the day in a parking-driving sequence, but neglect the possibility of charging at other CSs. In addition to home charging, only paper [29] considers parking lots and charging stations, but as independent entities capable of utilizing the EVs' flexibility.

#### 4.1.2. EV aggregators

Apart from observing a single CP or locational aggregation through microgrids, EVs can be seen as a decentralized source scheduled by an aggregator and without considering their location. Such models can have various goals, such as minimizing the EVs' total charging costs [30,31,33,35,38,39,43], minimizing frequency deviations [32,36] maximizing conditional value-at-risk [34], optimizing reserve provision [37] or maximizing revenue [42,40,41]. Paper [30] investigates a joint optimization of EVs and home energy scheduling, while [31] proposes a two-stage charging scheme for an EV aggregator to minimize the charging costs while taking uncertain renewable generation and aggregator's capacity into account. In [33,35] the authors describe a new optimization algorithm for optimizing manual reserve bids of EV aggregator. Paper [38] determines the optimal bidding strategy of an EV aggregator participating in the day-ahead energy and regulation markets using stochastic optimization. Authors of [39] develop a smart charging framework to identify the benefits of non-residential EV charging to the demand aggregators and the distribution grid. Paper [43] proposes necessary market adaptations to include EV aggregation in electricity markets. Paper [40] proposes a multi-stage stochastic model of a PEV aggregation agent to participate in day-ahead and

intraday electricity markets. On the hand paper [41] aims to determine the potential value that EVs could generate by providing reserve and identify EV user impacts on the provision of reserves.

Table 1 shows that papers related to EV aggregators mostly focus on home chargers within the CS-based concept (in [39] only non-residential chargers are observed) (*Issues 1 and 2*) and consider fixed power levels and only energy prices (*Issues 3 and 4*). For example, paper [36] presents a CS-based framework where aggregators group CSs while EVs migrate among them. On the other hand, authors of [42,43] do indeed model EVs' behaviour throughout the day, but only as availability periods at unspecified types of chargers, i.e. they do not address the fact that EVs charge and discharge at other CSs as well.

Although papers [30–36,38,42,43,41] model EVs connected to the distribution grid, they take into account only energy and/or balancing prices without network fees or infrastructure costs (*Issue 4*). Paper [39] apart energy tariffs take into account the peak demand chargers as well.

#### 4.1.3. Parking lots/charging stations

In addition to residential parking, EVs can also be charged at workplace/commercial/leisure parking lots or fast charging stations. EVs generally park at parking lots for longer times and power capacity of AC CPs is usually low to medium. On the other hand, EVs do not park at fast (DC) charging stations but only stop to charge, resembling the existing gas stations. Both the smart parking lot and charging station algorithms aim either at maximizing the benefits [44,45,47–51,57], or minimizing electricity costs [46,51–54] while preserving customers expectations. Parking lots could be seen equal to conventional technologies in power system operation process where they provide both energy and reserve [55]. Since many parking lots have integrated photovoltaics, it could be beneficial to optimize the charging at charging station and PV generation [56]. Table 1 shows that papers related to parking lots/charging stations are CS-based and specific locations are observed without proper multiple power levels (*Issue 3*) or costs (*Issue 4*). In [54] authors proposed optimal bi-directional charging control strategies to integrate electric vehicle in commercial and public parking facilities into the power grid as distributed energy resources for demand response programs by two-stage distributed optimization and water-filling algorithm. Paper [44] studies the optimal EV charging scheduling in a workplace parking lot, powered by both the PVs and the power grid. Research done in [45] solves the parking-lot EV charging scheduling problem through a noncooperative game approach. In [47] an optimization model for determining optimal mix of solar-based DG and storage units, as well as the optimal charging prices for EVs has been presented. Authors of [48] propose a centralized EV recharging scheduling system for parking lots using a realistic vehicular mobility/



parking pattern. In [49] an online intelligent demand coordination of EVs in distribution systems has been proposed. Paper [50] formulates an optimization model with central scheduler aiming to maximize the profit of smart household users. Authors in [51] propose an online charging strategy for EV charging stations in distribution systems while obeying power flow and bus voltage constraints. Paper [52] model a game that aims to minimize the total electricity cost at the utility company meanwhile maximizing the payoff of each charging station. In [53] the authors propose a novel cooperative charging strategy for a smart charging station in the dynamic electricity pricing environment, which helps EVs to economically accomplish the charging task by the given deadlines.

Papers [44–49] model workplace/commercial parking lots, while [50,57] observes residential private and public parking lots. Similarly, all the papers modeling CS operation tackle a specific CS connected to a single point in the grid and managed by a centralized controller [51–53], inflicting *Issues 1 & 2*.

With respect to *Issue 3*, i.e. insufficient power constraints, papers [44–46,49,50,57,51,55] use fixed CP power constraints at a parking lot or a CS without considering the OBC maximum power. In [48] the authors use one fixed value for OBC (the one of Nissan Leaf). Only paper [47] defines both the EV and the CP power limits, but it only considers CPs at their own parking lot. All the papers investigating CSs use only chargers’ power limits without mentioning the OBC power levels [51–53].

Unlike the majority of papers which do not consider any grid fees (*Issue 4*), the cost of charging in [47] includes both the electricity price and the grid fees, while [53,57] takes into account battery degradation costs.

#### 4.2. Industry practices and research projects

Current e-mobility related companies can be seen through three business schemes: Charging Point Operators (CPOs), E-Mobility Providers (EMPs), and energy-related companies (electricity suppliers, grid operators). CPOs are the companies operating and maintaining a pool of CPs, while EMPs provide charging services to EV users by enabling them access to CPs (authentication) and offering payment options. EVs have contracts only with EMPs who forward their customers’ payments to the CPOs. EMPs have contracts with many CPOs, while the CPOs have contracts with energy suppliers as well as grid operators. If energy arbitrage or flexibility provision through an aggregator is the target, EVs and EMPs cannot directly provide it, only the CPOs can. This is in line with the CS-based smart e-mobility, as illustrated in Fig. 4. On the other hand, in the EV-based e-mobility approach the aggregator

must be connected to EVs or EMPs. Grid fees are still assigned to CPOs because the physical connection does not change (see Fig. 2).

The Internet-of-Things (IoT), energy and e-mobility companies already took the CS-based path of the smart e-mobility [59–62]. The smart charging in the current industry practices usually means scheduling charging for household users at low electricity tariffs or cutting the peak load of larger CSs. Research projects such as [63–65] tackle mostly the issue of V2G testing on bidirectional chargers without integrating an aggregator into a real-world e-mobility system.

It is clear that the e-mobility industry does not yet operate within the EV-based smart e-mobility concept, which would change the role of the main beneficiaries in the smart environment from CPOs to EMPs.

#### 4.3. Proposed concept

The CS-based concept arises from a conventional way of addressing the EVs – they are an electric load stationary connected at a specific location to a specific CS. This CS does not have information about the EV’s battery SOE prior and after the connection and must forecast those values. In this sense, an EVA aggregates specific CSs physically located at households, parking lots or dedicated charging stations and their proper name should be EV Charger Aggregator or EVCA.

We argue that EVs should not be observed as conventional loads but as mobile batteries. EVA should not aggregate specific CSs but the EVs with their batteries. The new concept of EVA is therefore named EV Battery Aggregator or EVBA. EVBA continuously monitors and records EV information (SOE, planned trips) as a part of the future IoT concept. CPOs should allow all EVs to connect without restrictions but for a charging fee. CPOs should be understood as infrastructure operators similar to transmission/distribution system operators and charging a fee in a way that transmission and distribution fees (tariffs) are charged.

Additional benefits of the EVBA concept are the payment possibilities. Slow chargers are usually part of other consumer facilities and they are controlled within their smart environment (smart households, buildings, parking lots, etc.). It is not quite clear how an EVCA can aggregate CPs at someone else’s property. That is why each EV should have its own independent metering device so energy to/from an EV can be exactly measured as in the EVBA case.

Although EVBA is contrary to scientific research and current industry practises, as discussed in Sections 4.1 and 4.2, it is in line with the ISO 15118 standard, which foresees two controllers essential for deployment of a smart e-mobility system: an EV communication controller and a CP communication controller. In such advanced communication architecture, the EVBA can easily communicate the schedules to its EVs and the EVs can send all required data back to the EVBA. The data transfer between EVs and CSs can be easily achieved through EV and CP controllers.

### 5. Models

To demonstrate the arguments, models of both the EV-based (EVBA) and the CS-based aggregator (EVCA) are formulated in the following subsections and evaluated in the case study presented in Section 6.

#### 5.1. Nomenclature

##### 5.1.1. Abbreviations

- BMS Battery management system.
- CC-CV Constant-current-constant-voltage.
- CP Charging point.
- CS Charging station.
- DOD Depth-of-discharge.
- EV Electric vehicle.
- EVBA Electric vehicle battery aggregator.
- EVCA Electric vehicle charge aggregator.

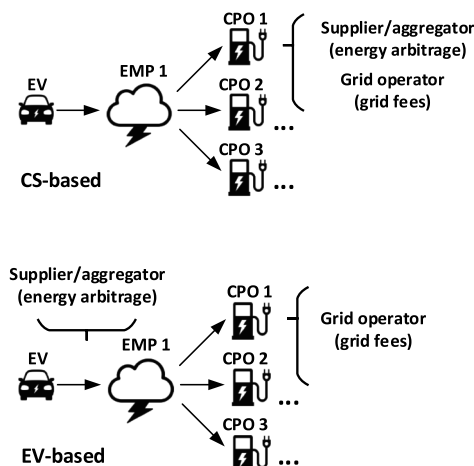

Fig. 4. Position of an aggregator and grid operator in the CS-based and EV-based concepts.

LIB Lithium-ion battery.  
 OBC On-board charger.  
 OF Objective function.  
 SOE State-of-energy.  
 V2G Vehicle-to-grid.

### 5.1.2. Sets and indices

$\mathcal{CP}$  Set of charging points, indexed by  $cp$ .  
 $\mathcal{T}$  Set of time steps, indexed by  $t$ .  
 $\mathcal{V}$  Set of vehicles, indexed by  $v$ .

### 5.1.3. Input parameters

$C_v^{\text{BAT}}$  Capital battery cost of vehicle  $v$  (€).  
 $C_{v,t,cp}^{\text{CP\_FCH}}$  Charging point fee for fast chargers at charging point  $cp$  (€/kWh).  
 $C_{v,t,cp}^{\text{CP\_SCH}}$  Charging point fee for slow chargers at charging point  $cp$  (€/kWh).  
 $C_t^{\text{EP}}$  Electricity price during period  $t$  (€/kWh).  
 $C_{v,t,cp}^{\text{G\_FCH}}$  Grid tariff for fast chargers at charging point  $cp$  (€/kWh).  
 $C_{v,t,cp}^{\text{G\_SCH}}$  Grid tariff for slow chargers at charging point  $cp$  (€/kWh).  
 $CAP_v^{\text{BAT}}$  Battery capacity of vehicle  $v$  (kWh).  
 $D_1^{\text{BAT}}$  Fixed battery degradation coefficient for higher values of depth-of-discharge.  
 $D_2^{\text{BAT}}$  Variable battery degradation coefficient (based on discharged energy) for higher values of depth-of-discharge.  
 $D_3^{\text{BAT}}$  Variable battery degradation coefficient (based on depth-of-discharge) for higher values of depth-of-discharge.  
 $D_4^{\text{BAT}}$  Variable battery degradation coefficient (based on discharged energy) for lower values of depth-of-discharge.  
 $E_{cp}^{\text{CP\_MAX}}$  Maximum energy limit of charging point  $cp$  during one time step (kWh).  
 $E^{\text{FCH\_MAX}}$  Maximum energy limit of fast charging point during one time step (kWh).  
 $E_v^{\text{OBC\_MAX}}$  Maximum energy limit of OBC of vehicle  $v$  during one time step (kWh).  
 $E_{v,t}^{\text{RUN}}$  Energy consumed for mobility purposes of vehicle  $v$  during time step  $t$ .  
 $SOE_{v,cp}^{\text{ARR}}$  Anticipated SOE at time of arrival at  $cp$  of vehicle  $v$  in a CS-based system.  
 $SOE_v^{\text{CV}}$  SOE curve breaking point between CC and CV charging phases of vehicle  $v$  (%).  
 $SOE_{v,cp}^{\text{DEP}}$  Anticipated SOE at time of departure from  $cp$  of vehicle  $v$  in a CS-based system.  
 $SOE_v^{\text{MIN}}$  Minimum allowed SOE of vehicle  $v$  (%).  
 $SOE_v^{\text{MAX}}$  Maximum allowed SOE of vehicle  $v$  (%).  
 $SOE_v^0$  Initial SOE of vehicle  $v$  (%).  
 $T_{v,cp}^{\text{ARR}}$  Time step when vehicle  $v$  arrives at charging point  $cp$  in a CS-based system.  
 $T_{v,cp}^{\text{DEP}}$  Time step when vehicle  $v$  departs from charging point  $cp$  in a CS-based system.  
 $T_{v,cp}^{\text{OFF}}$  Set of time steps when vehicle  $v$  when vehicle  $v$  is disconnected from charging point  $cp$  in a CS-based system.  
 $T_{v,cp}^{\text{ON}}$  Set of time steps when vehicle  $v$  is connected to charging point  $cp$  in a CS-based system.  
 $\eta^{\text{DCH}}$  EV V2G discharging efficiency.  
 $\eta^{\text{FCH}}$  EV fast charging efficiency.  
 $\eta^{\text{RUN}}$  EV mobility discharging efficiency.  
 $\eta^{\text{SCH}}$  EV slow charging efficiency.  
 $\mathbb{1}_{v,t,cp}$  Matrix indicating whether vehicle  $v$  is connected to charging point  $cp$  at time step  $t$ .

### 5.1.4. Variables

$c_{v,t}^{\text{DEG}}$  Degradation cost of vehicle  $v$  at time  $t$  (€).  
 $c^{\text{EV}}$  Overall cost of charging all EVs (€).  
 $e_{v,t}^{\text{DCH}}$  Energy discharged from vehicle  $v$  at time  $t$  (kWh).  
 $e_{v,t}^{\text{FCH}}$  Energy fast charged to vehicle  $v$  at time  $t$  (kWh).  
 $e_{v,t}^{\text{SCH}}$  Energy slow charged to vehicle  $v$  at time  $t$  (kWh).  
 $soe_{v,t}^{\text{EV}}$  State-of-energy of vehicle  $v$  at time  $t$  (kWh).

### 5.2. Mathematical formulation of an EV-based aggregator

Objective function minimizes the total EV charging costs:

$$\begin{aligned} \min_{\Xi} c^{\text{EV}} &= \sum_{v \in \mathcal{V}} \left[ \sum_{t \in \mathcal{T}} (e_{v,t}^{\text{SCH}} \cdot (C_t^{\text{EP}} + C_{v,t,cp}^{\text{G\_SCH}} + C_{v,t,cp}^{\text{CP\_SCH}}) - e_{v,t}^{\text{DCH}} \cdot C_t^{\text{EP}} + c_{v,t}^{\text{DEG}} \right. \\ &\quad \left. + e_{v,t}^{\text{FCH}} \cdot (C_t^{\text{EP}} + C_{v,t,cp}^{\text{G\_FCH}} + C_{v,t,cp}^{\text{CP\_FCH}}) \right]. \end{aligned} \quad (6)$$

The first row in Eq. (6) corresponds to payments due to EV charging at slow chargers, where  $e_{v,t}^{\text{SCH}}$  is charged energy,  $C_t^{\text{EP}}$  is energy price,  $C_{v,t,cp}^{\text{G\_SCH}}$  is the grid fee for slow chargers<sup>3</sup> and  $C_{v,t,cp}^{\text{CP\_SCH}}$  is the CS fee. The second row represents EV discharging income and cost of degradation, where  $e_{v,t}^{\text{DCH}}$  is the amount of discharged energy,  $C_t^{\text{EP}}$  is V2G revenue and  $c_{v,t}^{\text{DEG}}$  battery degradation cost. The third row captures payments due to EV charging at fast chargers,<sup>4</sup> where  $e_{v,t}^{\text{FCH}}$  is the amount of charged energy,  $C_{v,t,cp}^{\text{G\_FCH}}$  is the grid fee for fast chargers, and  $C_{v,t,cp}^{\text{CP\_FCH}}$  is the fast CS fee. EV slow charger charging fees depend on the type of charger, e.g. this fee is zero for home chargers. On the other hand, EV fast charging is modeled using only one fast charging type and cost. In order to add additional services to grid operators, the objective function should be reformulated with new revenue streams/costs. For example, provision of reserves would require addition of the reservation and activation fees. Grid congestion management could be added by reformulating the grid fees and making them more expensive during the peak periods etc.

Charging/discharging energy constraints are:

$$e_{v,t}^{\text{SCH}}, e_{v,t}^{\text{DCH}}, e_{v,t}^{\text{FCH}} \geq 0 \quad \forall v \in \mathcal{V}, t \in \mathcal{T}; \quad (7)$$

$$e_{v,t}^{\text{SCH}} \leq \sum_{cp \in \mathcal{CP}} \mathbb{1}_{v,t,cp} \cdot E_{cp}^{\text{CP\_MAX}} \quad \forall v \in \mathcal{V}, t \in \mathcal{T}; \quad (8)$$

$$e_{v,t}^{\text{DCH}} \leq \sum_{cp \in \mathcal{CP}} \mathbb{1}_{v,t,cp} \cdot E_{cp}^{\text{CP\_MAX}} \quad \forall v \in \mathcal{V}, t \in \mathcal{T}; \quad (9)$$

$$e_{v,t}^{\text{SCH}} \leq E_v^{\text{OBC\_MAX}} \quad \forall v \in \mathcal{V}, t \in \mathcal{T}; \quad (10)$$

$$e_{v,t}^{\text{DCH}} \leq E_v^{\text{OBC\_MAX}} \quad \forall v \in \mathcal{V}, t \in \mathcal{T}; \quad (11)$$

$$e_{v,t}^{\text{SCH}} \leq E_v^{\text{OBC\_MAX}} \cdot \frac{1 - soe_{v,t}^{\text{EV}}}{1 - SOE_v^{\text{CV}} \cdot CAP_v^{\text{BAT}}} \quad \forall v \in \mathcal{V}, t \in \mathcal{T}; \quad (12)$$

$$e_{v,t}^{\text{FCH}} \leq \sum_{cp \in \mathcal{CP}} \mathbb{1}_{v,t,cp} \cdot E_{cp}^{\text{FCH\_MAX}} \quad v \in \mathcal{V}, t \in \mathcal{T}. \quad (13)$$

Constraint (7) imposes nonnegativity on all energy variables. Constraints (8) and (9) limit the energy charged/discharged at slow CSs based on the mapping parameter  $\mathbb{1}_{v,t,cp}$  that determines which EV is connected to which CP at each time step. As the EVs move between

<sup>3</sup> Slow chargers refer to AC chargers, i.e. the ones that require OBC to convert alternating to direct current.

<sup>4</sup> Fast chargers refer to DC chargers, i.e. the ones that convert alternating to direct current and circumvent the OBC. Therefore, the OBC capacity is not relevant when using fast chargers.

different CPs, maximum charging power depends on index  $cp$ . OBC limits on EV slow charging and discharging are imposed by constraints (10) and (11), respectively. The OBC power capacity  $E_v^{OBC-MAX}$  depends only on the EV type. Constraint (12) additionally constrains the OBC charging power at high state-of-energy (SOE) due to inherent nature of the li-ion battery (LIB) charging process consisting of the constant-current (CC) and the constant-voltage (CV) part. Parameter  $SOE^{CV}$  is empirically obtained and indicates SOE value (in percentage) at which the constant voltage phase starts. More information on this formulation can be found in [32,66]. Finally, the fast charging power limit  $E^{FCH-MAX}$  is imposed by constraint (13).

LIB degradation is calculated as follows:

$$c_{v,t}^{DEG} \geq C_v^{BAT} \cdot (D_1^{BAT} + D_2^{BAT} \cdot \frac{e_{v,t}^{DCH}}{CAP_v^{BAT}} \cdot 100 + D_3^{BAT} \cdot \frac{1 - soe_{v,t}^{EV}}{CAP_v^{BAT}} \cdot 100) \quad \forall v \in \mathcal{V}, t \in \mathcal{T}; \quad (14)$$

$$c_{v,t}^{DEG} \geq C_v^{BAT} \cdot (D_4^{BAT} \cdot \frac{e_{v,t}^{DCH}}{CAP_v^{BAT}} \cdot 100) \quad \forall v \in \mathcal{V}, t \in \mathcal{T}. \quad (15)$$

LIB degradation depends on four main variables: charging/discharging current, voltage, temperature and cell balance. In most LIB applications the last two variables are kept at optimal operating point by a dedicated battery management system (BMS) and they can be left out of the degradation model. During slow AC charging the currents are rather low (up to  $0.2C^5$ ) and their impact on degradation is negligible. Thus, the only variable that must be taken into account is voltage, which is closely related to SOE, thus constraints (17) and (18) keep the voltage within the allowed range. In order to consider degradation, a penalization cost is introduced as in [67], but in a linearized form in order to avoid binary variables [68]. Geometric surface of the linearized degradation cost is modeled by constraint (14), which includes two variables: discharged energy and depth-of-discharge ( $DOD = 1 - SOE$ ). Constraint (15) is an additional geometric surface binding at higher values of SOE when surface from eq. (14) goes to zero or becomes negative. Constraint (15) depends only on discharged energy. Parameters  $D_{1-4}$  are obtained using the best-fit option applied to LIB degradation data (life-cycle loss vs. DOD) from [69].

Energy balance constraints are:

$$soe_{v,t}^{EV} = soe_{v,t-1}^{EV} + e_{v,t}^{SCH} \cdot \eta^{SCH} - e_{v,t}^{DCH} / \eta^{DCH} - E_{v,t}^{RUN} / \eta^{RUN} + e_{v,t}^{FCH} \cdot \eta^{FCH} \quad \forall v \in \mathcal{V}, t \in \mathcal{T}; \quad (16)$$

$$soe_{v,t}^{EV} \geq SOE_v^{MIN} \cdot CAP_v^{BAT} \quad \forall v \in \mathcal{V}, t \in \mathcal{T}; \quad (17)$$

$$soe_{v,t}^{EV} \leq SOE_v^{MAX} \cdot CAP_v^{BAT} \quad \forall v \in \mathcal{V}, t \in \mathcal{T}; \quad (18)$$

$$soe_{v,t}^{EV} \geq SOE_v^0 \cdot CAP_v^{BAT} \quad \forall v \in \mathcal{V}, t = 24; \quad (19)$$

Eq. (16) is the main energy balance equation calculated for each vehicle  $v$  and time step  $t$ . Energy accumulated during the current time step must be equal to the energy accumulated in the previous time step plus the energy withdrawn from the grid via slow or fast charging points and minus the energy discharged for motion or back into the grid. In the first time step the term  $soe_{v,t-1}^{EV}$  is substituted with  $SOE_v^0$ , which corresponds to energy stored in vehicle  $v$  before the first time step. Constraints (17) and (18) limit the battery capacity of each EV, while constraint (19) sets the minimum SOE in the last time step (i.e. the SOE in the last timestep must be greater or equal the initial SOE).

### 5.3. Mathematical formulation of a CS-based aggregator

Mathematical model of the CS-based aggregator is:

<sup>5</sup> C-rate is the ratio of the charging (or discharging) power and battery energy capacity.

min (1)

subject to

$$(2) - (10), (12) - (14) \\ soe_{v,t}^{EV} = soe_{v,t-1}^{EV} + e_{v,t}^{SCH} \cdot \eta^{SCH} - e_{v,t}^{DCH} / \eta^{DCH} + e_{v,t}^{FCH} \cdot \eta^{FCH} \quad \forall v \in \mathcal{V}, t \in T_{v,CP}^{ON}, \quad (20)$$

$$soe_{v,t}^{EV} = SOE_{v,CP}^{ARR}, \quad \forall v \in \mathcal{V}, t = T_{v,CP}^{ARR}, cp \in CP; \quad (21)$$

$$soe_{v,t}^{EV} \geq SOE_{v,CP}^{DEP}, \quad \forall v \in \mathcal{V}, t = T_{v,CP}^{DEP}, cp \in CP. \quad (22)$$

It contains all constraints as the EV-based aggregator model except for (16), which is replaced with constraints (20)–(22). Energy balance constraint (20) does not include energy discharge for driving as it only tracks the EVs when they are connected to a CP. Hence the time domain in eq. (20) is  $T_{v,CP}^{ON}$ . Eqs. (21) and (22) are used to set the anticipated SOE at arrival and required SOE at departure from each CP.

## 6. Results and discussion

The models elaborated in Section 5 are validated on the small test-case which is elaborated in details in Section 2. The small test case considers the most frequent trip combinations and therefore provides adequate representation of the EV fleet while preserving simplicity and readability of the paper. *Issues 1 & 2* (insufficient information on EV behavior at other CSs and inability to transfer flexibility between CSs) are observed together as they both depend on the EVs' daily SOE curve. *Issues 3 & 4* (insufficient power constraints and incomplete costs) are addressed individually and only for the EVBA case, as their repercussions are the same for both models.

### 6.1. Input data

The proposed model resembles a price taker scheme where an aggregator forecasts prices in order to efficiently submit its energy bids in the market. Although both the prices, driving activity and times of arrival and departure from CPs are stochastic parameters, we consider all parameters deterministic for better demonstration of optimality of both formulations, as well as quantification of the resulting schedules.

We use historic energy prices data for year 2018 from EPEX power exchange in France. Three sets are used resembling high, medium and low volatility of electricity prices, as shown in Fig. 5. The high-volatility prices date from Nov. 21, medium from March 11, and low from June 30. Each charger type has different grid and charger tariff fee, as listed in Table 2. All grid fees are modeled using a two-tariff system: night and day, and the fees are aligned with the ones in [70]. Grid fees represent both transmission and distribution fees, while charger fees are used to retrieve investment and cover for operation and maintenance costs of the charging infrastructure. Generally, higher charger power results in lower grid fees, but higher charger fees. Charger fees are obtained from real fast charging fees in [71,72] reduced by average energy price and grid tariff fees and scaled based on investment cost to match the corresponding charger type. The investment costs of chargers are from [73].

Efficiencies used in this paper are as follows: slow charging  $\eta^{SCH} = 0.95$ , discharging for driving  $\eta^{RUN} = 0.90$ , discharging to drive  $\eta^{DCH} = 0.85$ , and fast charging  $\eta^{FCH} = 0.80$ . SOE parameters used for all EVs are following:  $SOE^{MAX} = 1.00$ ,  $SOE^{MIN} = 0.20$ ,  $SOE^{CV} = 0.80$ , and  $SOE^0 = 0.60$ . Battery capacities are 20 kWh for EV1, 40 kWh for EV2 and 60 kWh for EV3. Battery degradation parameters are:  $D_1^{BAT} = -0.342900$ ,  $D_2^{BAT} = 0.034030$ ,  $D_3^{BAT} = 0.004287$ , and  $D_4^{BAT} = 0.008317$ .

To highlight *Issues 1 & 2* in the EVCA model, two different values of  $SOE_{v,CP}^{DEP}$  are used. The first one corresponds to a conservative driver who sets the SOE before every trip to at least 95% (nearly full), and we name this model *high-SOE*. The second one corresponds to a risk-prone driver

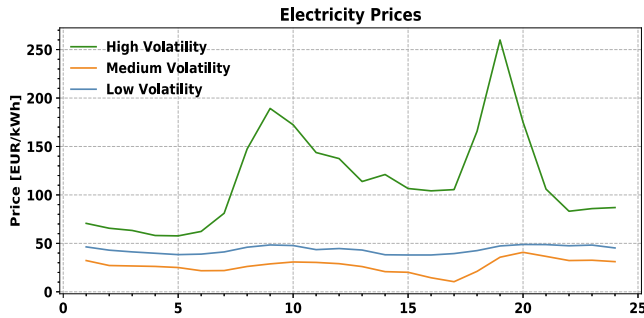

Fig. 5. Three electricity price scenarios from EPEX taken for days with the highest/average/lowest price volatility in 2018.

Table 2  
Charger point (CP) data used for the simulations (kW and €/kW).

CP Type	Description	Power (kW)	Grid Low (€/kW)	Grid High (€/kW)	CP Tariff (€/kW)
1	Home	4	0.022840	0.047040	0.004000
2	Work	8	0.016120	0.033600	0.018300
3	Leisure	12	0.016120	0.033600	0.030000
4	DC Fast	100	0.010750	0.022840	0.200000

willing to earn more for providing flexibility at an expense of its EV range. This person sets the SOE before every trip to at least 60%. We name this model *low-SOE*. Note that most models in literature assume a conservative driver who always desires (nearly) full battery at departure.

6.2. Issues 1 & 2

The results related to *Issues 1 & 2* are displayed in Figs. 6–10. Results in Fig. 6a indicate that in total, i.e. combined for all three EVs, the EVBA model results in the lowest charging costs for all price volatility scenarios, followed by the EVCA low-SOE, while the worst results are achieved for the EVCA high-SOE model. Detailed individual EV costs are shown in Fig. 7, where the EVBA model provides the cheapest solution for all three EVs over all price volatility scenarios, while the two EVCA cases alternate in terms of the quality of the solution. For EV1, the high-SOE case is always a better option, while for EV2 the low-SOE case is a better option for all price scenarios. For EV3 however, in low-volatility price scenario the high-SOE case yields better results, while in medium- and high-volatility scenarios the low-SOE case performs better. The reason for EVBA superiority over the EVCA models are twofold: (i) in the EVCA models the EVs are often charged at high prices and (ii) their energy arbitrage opportunities are reduced due to strict SOE requirements. Generally, all three models discharge most energy in

the high-volatility price scenario as such scenario favors arbitrage, as can be seen in Fig. 6b. In the low-volatility scenario the EVBA model is the least aggressive in V2G mode, but in the high-volatility scenario it discharges the most energy. In all price-volatility scenarios the EVBA model observes price differences during the whole day and adjusts its discharging schedule accordingly. On the other hand, in EVCA models the CSs are blind to prices outside of the timeframe when an EV is connected to them and they need to adjust their discharging quantities to keep the departing SOE at the minimum allowed level. This happens even if this discharge incurs higher recharging costs at subsequent CSs.

In general, higher price volatility yields lower costs in all three cases. However, the EVBA model is able to better monetize flexibility over the day and the charging costs reduce drastically as the price volatility increases (EV2 generates profit already in medium-volatility price scenario). This is highly related to *Issue 2* (transfer of flexibility between CSs). Since the EVBA model observes EVs throughout the day, it can schedule optimal amount of discharging when prices are high allowing the EVs to drive to another CSs with sufficient SOE.

*Issue 1* (problems with SOE prediction at EV arrival) are analyzed in details in Figs. 8–10 for the highly volatile price scenario. In all three figures the periods when EVs are parked at CSs, are shaded in the respective CS color. In case of EV1 and highly volatile prices, the first driving period precedes the periods of high prices. In the EVBA model, EV1 charges before the first trip and discharges after, as shown in Fig. 8b. It recharges before the second trip (during the low-price hours 13–16) and again discharges at the next CS. It charges for the last time at the end of the day at low prices. A similar schedule is obtained with the EVCA high-SOE model. However, CS1 is oblivious to the low prices in the afternoon and slightly discharges EV1 in hour 7, as opposed to the EVBA model that charges EV1 in hour 7 (compare Figs. 8b and 8c). To make up for this lack of energy, the high-SOE EVCA model needs to charge more energy in hour 14 than the EVBA model. This is sub-optimal since the price in hour 14 is much higher than in hour 7. The charging quantities in all the other hours are the same. Graph in Fig. 8d indicates that the EVCA low-SOE model behaves quite differently than the other two. Since the CS before the first trip only satisfies the EV’s desired SOE of 60% at the departure and at the same time minimizes costs of EV charging only at this CS, it significantly discharges EV1 before the first trip. When prices are highest, after the first trip, EV1 discharges much less energy than in the other two cases due to lower SOE after the trip. Before the second trip, EV1 is again charged only to satisfy the desired SOE at the next departure time, and therefore has less energy to be discharged after the second trip (compare hours 19 and 20). Considering the SOE graphs and charging schedules from Fig. 8, the conclusion is that the EVCA high-SOE model performs much closer to the optimal EVBA model than the EVCA-low model.

In the case of EV2 and highly volatile prices (Fig. 9) the first driving period takes place after the periods of high prices. In the EVBA model, whose charging schedule is shown in Fig. 9b, EV2 charges early in the

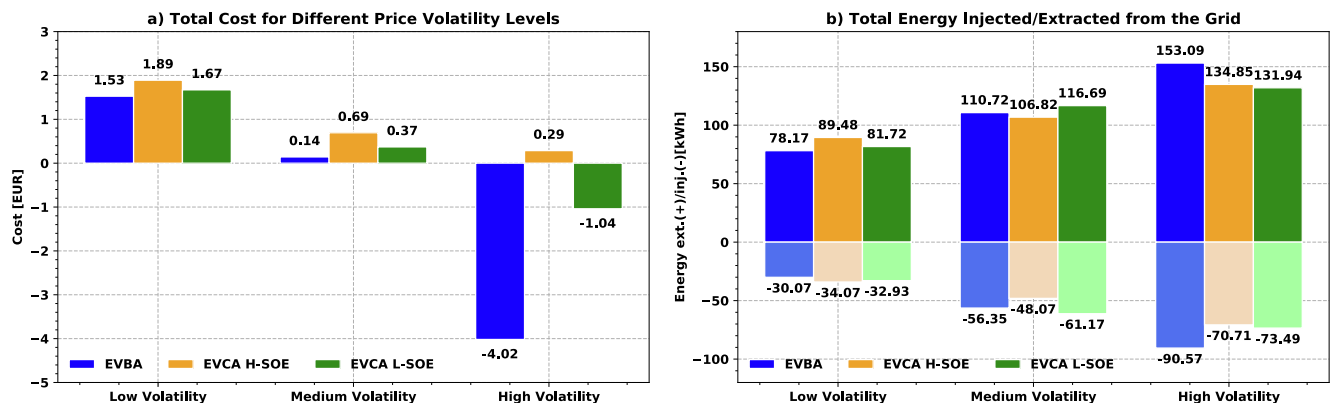

Fig. 6. Results related to *Issues 1 & 2*, showing total charging costs and energy injection/extraction for all three EVs.



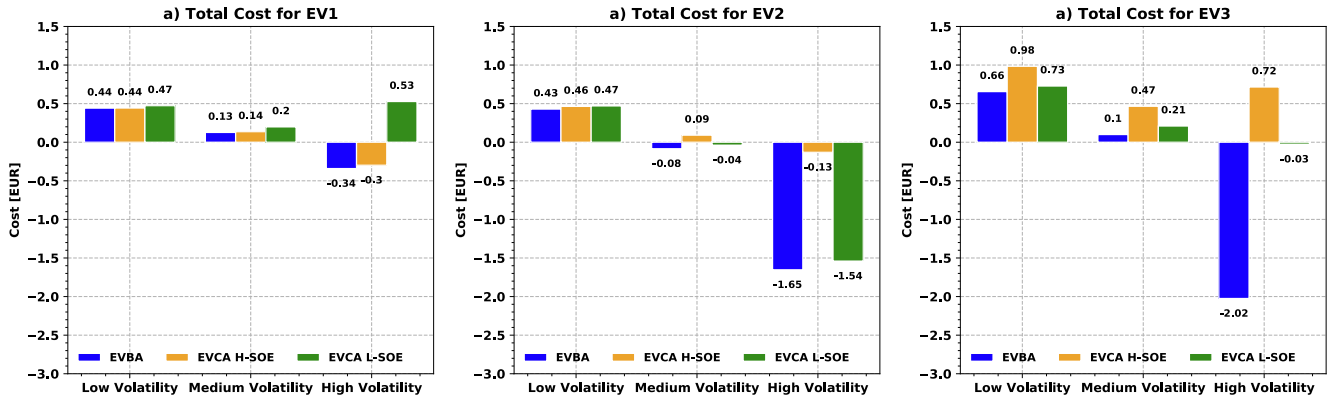

Fig. 7. Results related to Issues 1 & 2, showing total charging costs for each EV individually.

morning and discharges before the first trip taking advantage of peaking prices in hours 8–11. It fully recharges after the first trip (hours 15–17) to be able to fully discharge during hours 18–20. Energy for the second trip is charged just before the trip, in hour 21, at very low cost. The required SOE is achieved by charging EV2 after the final trip at low cost (hours 23 and 24). Comparison of the EVBA charging schedule and the low-SOE EVCA schedule in Fig. 9d, as well as the corresponding daily SOE curves in Fig. 9a, indicates that the low-SOE EVCA model behaves quite similar to the optimal EVBA model. The only differences are as follows:

- The EVCA low-SOE model discharges less energy in hour 11 as it requires at least 60% of SOE at departure.
- Due to higher SOE, the EVCA low-SOE model requires less charging in hour 17. Since the electricity price in hour 11 is much higher than in hour 17, this model overlooked an arbitrage opportunity between those hours.
- Again, due to 60% required SOE, the EVCA low-SOE model discharges less energy in hour 18.

- Due to higher SOE, the EVCA low-SOE model requires less charging in hour 24. Again, it did not exercise arbitrage between hours 18 and 24 due to a required SOE level at departure.

The results of the high-SOE EVCA are shown in Fig. 9c. This model does not take advantage of discharging at higher prices due to a more constrained SOE requirement at departure and thus results in much worse solution. For instance, instead of discharging in hours 8–11 as the EVBA and EVCA low-SOE models, the EVCA high-SOE model is, due to the departing SOE restriction, only able to perform partial discharge in hour 9. This repeats again in the evening hours when the EVCA high-SOE model is only able to perform discharge in hour 19, instead of hours 18–20. As a consequence, the EVCA high-SOE model is left with a lot of energy stored in the late evening hours. This energy is partially discharged in the last two hours of the day, but at a relatively low profit.

The EV3 case for the highly volatile prices is shown in Fig. 10. In the EVBA model (Fig. 10b), EV3 charges before the first trip and discharges after it to take advantage of peak hours 9 and 10. It recharges before the

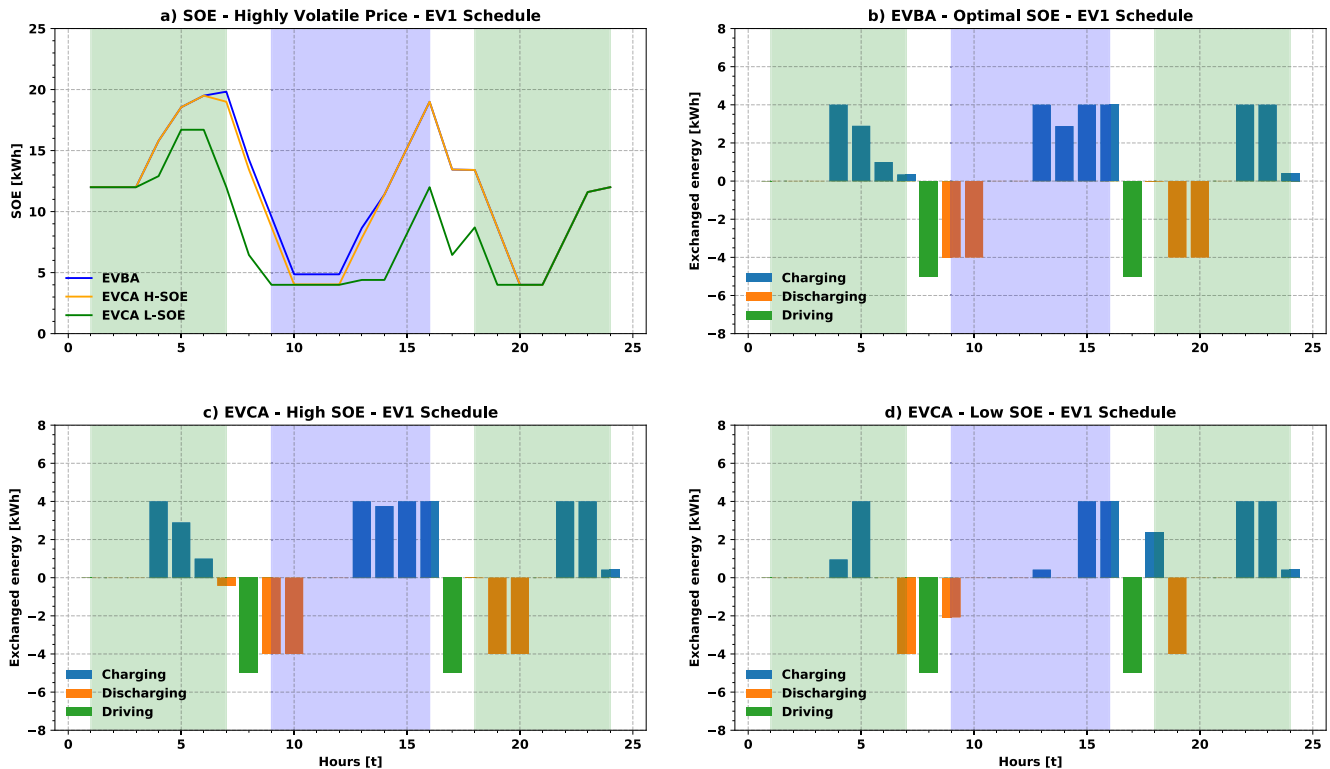

Fig. 8. Results related to Issues 1 & 2, EV1 schedules for the highly volatile price scenario.

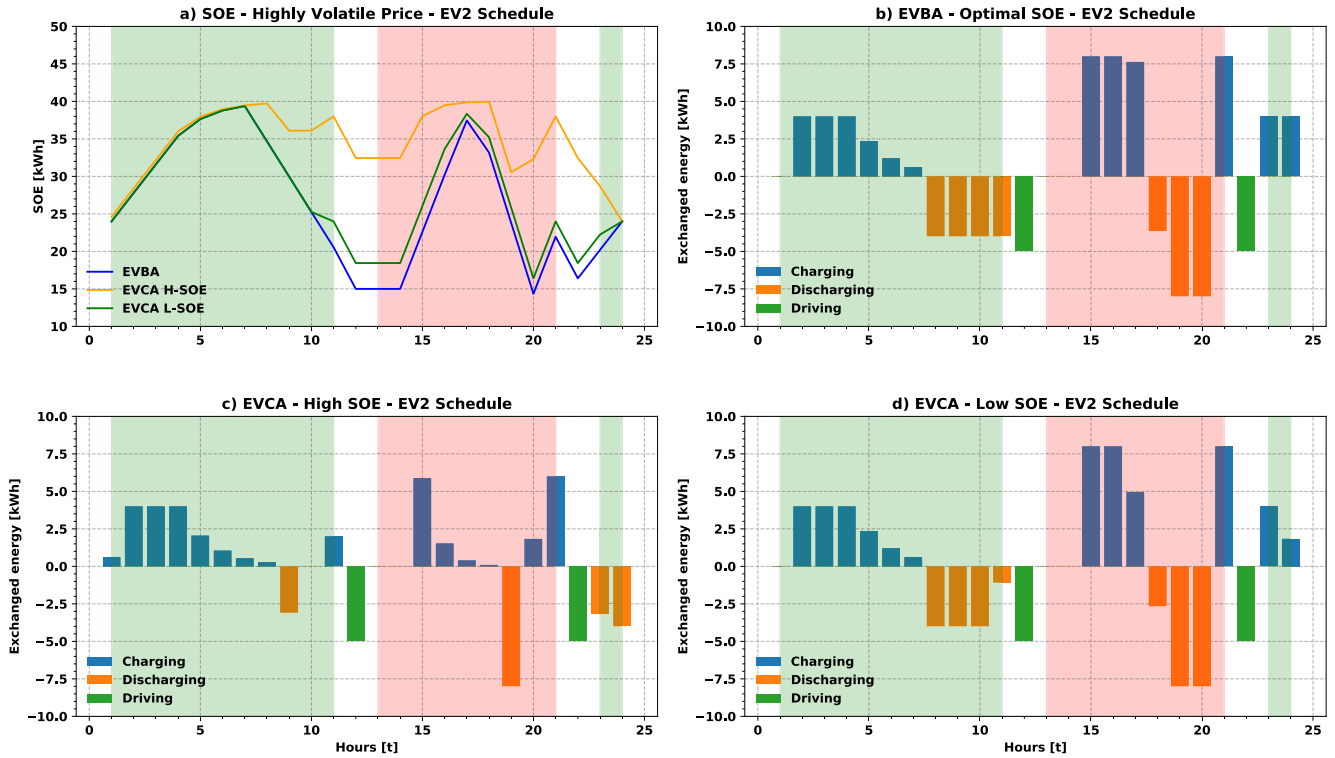

Fig. 9. Results related to Issues 1 & 2, EV2 schedules for the highly volatile price scenario.

second trip to be able to discharge again after the trip, thus performing arbitrage. It again recharges before and after the third trip to meet the required end-of-day SOE. Graphs in Fig. 10a indicate that optimal EVBA case is similar to the high-SOE EVCA case during the morning and the daytime, but during the evening it resembles the low-SOE case. The morning charging period at CS1 (green area) ends at hour 7, when the

high-SOE EVCA model charges EV3 to 95%. This is quite similar to the optimal EVBA model, which charges EV3 only to a slightly higher SOE. At CS2 (blue area), the high-SOE model charges the EV again to 95%, while the EVBA model charges it slightly below that value. The major difference occurs in the evening hours at CS3 (red area), where the high-SOE EVCA model again charges EV3 to 95%, while the

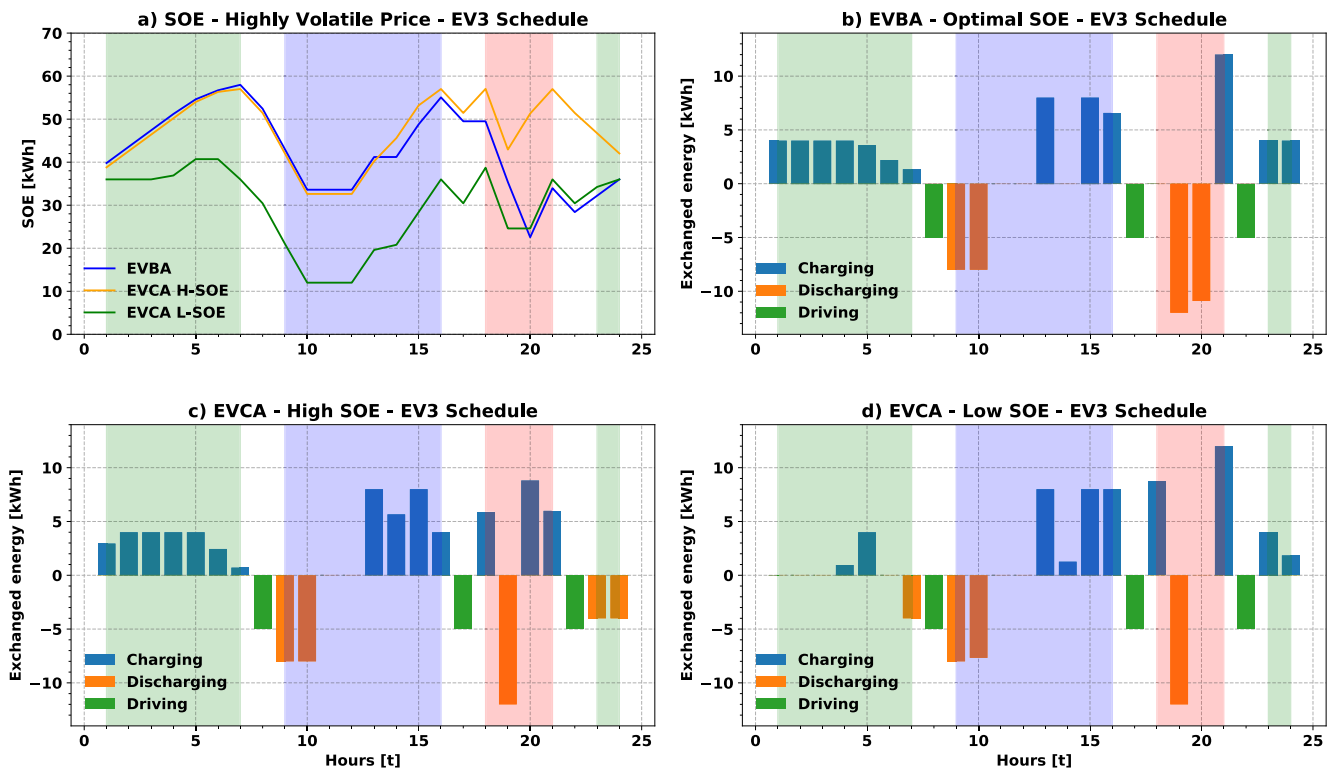

Fig. 10. Results related to Issues 1 & 2, EV3 schedules for the highly volatile price scenario.

EVBA model charges it to only 33 kWh in hour 21. This demonstrates the negative effect of constraint on the departure SOE in the high-SOE EVCA model. EV3 is thus required to charge instead of discharge at very high prices. Consequently, after the final trip it has more energy than required by the end-of-day SOE constraint and CS1 (green area) discharges it, but at a low gain, in hours 23 and 24.

The EVCA low-SOE case schedules EV3 quite differently before the first and second trips. It does not charge as much energy since the required SOE before the trips is only 60%. This enables it to perform arbitrage at CS1 and discharge a part of the energy in hour 7 just before the trip (Fig. 10c). Since hours 9 and 10 are peak-price hours, it discharges more energy and charges again in hours 13–16 at lower prices. It again performs arbitrage in hours 19 and 21, but with much lower energy volume than the EVBA model. Based on the conducted analysis, we derive the following conclusions:

1. for EV1, the high-SOE EVCA model is close to the optimal EVBA model;
2. for EV2, the low-SOE EVCA model is close to the optimal EVBA model,
3. in the case of EV3, the high-SOE EVCA model is close to the optimal EVBA solution until evening, but during the evening and night the low-SOE EVCA case becomes more similar to the optimal EVBA solution.

Therefore, without the EVBA optimization model there is no way to decide what is the best required SOE at the time of departure to maximally transfer flexibility and utilize daily energy arbitrage.

### 6.3. Issue 3

To analyze Issue 3 (insufficient power constraints), we examine the results of the EVBA model with highly volatile prices using four different sets of power constraints. First, we use fixed power constraint of 4 kW throughout the day. Second and third sets of constraints use only OBC and CP power constraints, respectively. The fourth set of constraints uses both the OBC and CP power constraints.

As shown in Fig. 11a, the minimum expected costs are obtained when using only OBC power constraint, followed by the CP-only power constraint, then both power constraints, while the highest cost is obtained for a fixed 4 kW power constraint. This is a direct result of energy arbitrage volumes shown in the same chart. In order to verify feasibility of the obtained charging schedules, Fig. 11b shows the exceeded OBC and CP limits. The green shaded areas indicate that the injected/extracted power exceeds the CP limit, while the orange shaded areas indicate the surpassed CP limit. The CP power limit is exceeded in hours 3, 8–10, 23 and 24 by the OBC-only case as the OBC rated power is higher than the CS1 rated power. On the other hand, the OBC power capacity is exceeded in hours 15, 16, 19–21 by the CP-only case as the

OBC capacity is lower than the CP capacity during those hours. Cases with fixed 4 kW power constraint and inclusion of both the OBC and CP power constraints never exceed the power limits. Therefore, the cases with only OBC and only CP power constraints provide higher revenues only at first sight. However, their real-time operation cannot be physically carried out and they would suffer from additional balancing costs not included in Fig. 11a. On the contrary, if EVs are too constrained, as in the case with fixed 4 kW power limit, the EV charging schedule is overconstrained, which diminishes the arbitrage opportunities. This brings us to conclusion that considering both the OBC and CP power constraints results in optimal solution.

### 6.4. Issue 4

From mathematical perspective, Issue 4 (incomplete costs) deals with different terms in the objective function. Fig. 12 shows that adding the cost terms usually omitted in the existing literature significantly reduces the attractiveness of energy arbitrage. Five objective functions (OF) with different elements are observed:

1. OF1: base case with only the cost of electricity,
2. OF2: cost of electricity and battery degradation costs,
3. OF3: cost of electricity and grid tariff,
4. OF4: cost of electricity and CS tariff,
5. OF5: all the costs, including cost of electricity, battery degradation costs, grid tariff and CS tariff.

The graph in Fig. 12a shows that the total cost rises from  $-4.0$  € in the electricity-only case to  $3.6$  € in the case with all relevant costs included, which makes a huge difference in the EV charging economics. The main factor are degradation costs (OF2 value is  $2.2$  €), while the lowest impact has the CS tariff (OF4 value is  $-1.9$  €).

The overall costs are in direct relation with the volume of arbitrage as the spread in the price between the purchased and is the sold electricity needs to cover for additional costs of battery degradation and tariffs. Therefore, OF5 results in the least charged energy, followed by OF2, as shown in Fig. 12b. With respect to this, total discharged energy reduced from  $90,57$  kWh in the OF1 case to a mere  $4,07$  kWh in the all-costs case, as shown in Fig. 12c.

## 7. Conclusion

This paper has demonstrated on a small example the shortcomings of the Charging station based concept, which is predominantly used in the research community. The main drawback of this concept is that it observes the electric vehicle batteries only when connected to a specific charging station. This results in suboptimal charging schedules and aggregator revenues. Furthermore, charging stations have to forecast the battery parameters (arrival and departure times and SOE at arrival

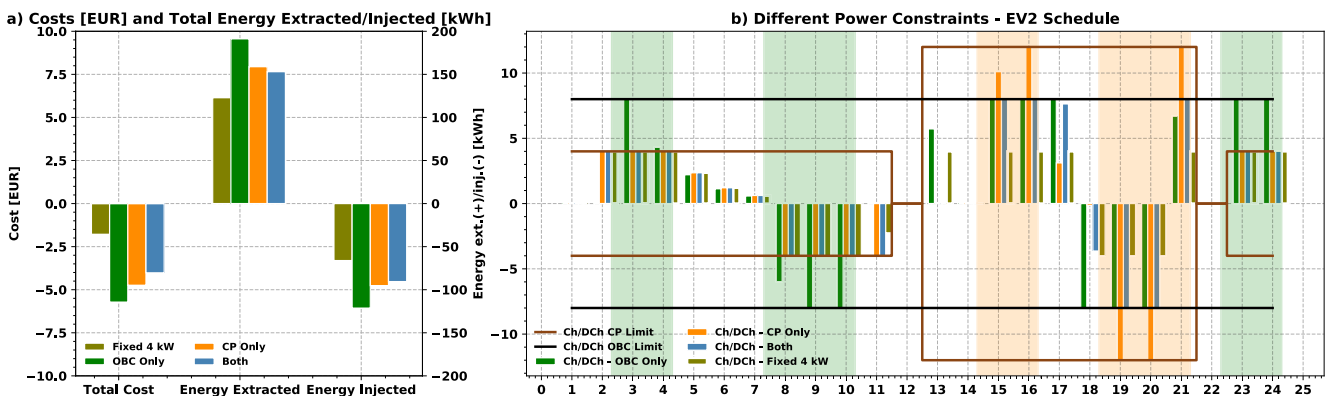

Fig. 11. Results related to Issue 3; left figure - total costs for different sets of power constraints, right figure - EV2 charging schedule for different power constraints.

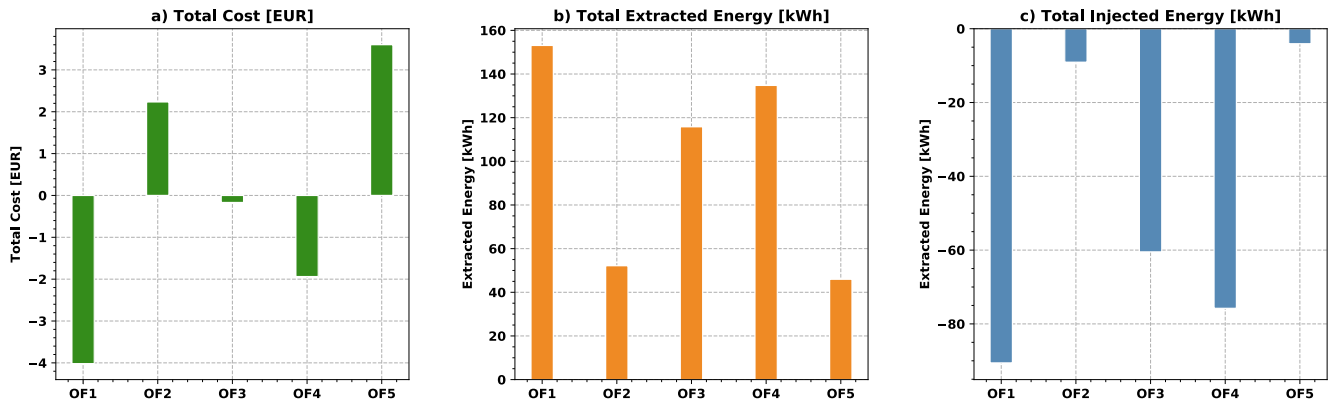

Fig. 12. Results related to *Issue 4*, total charging costs for different objective functions (OF1 – only cost of electricity; OF2: cost of electricity + degradation cost; OF3: cost of electricity + grid tariff; OF4: cost of electricity + CS tariff, OF5: electricity cost + degradation cost + grid tariff + CS tariff).

and departure), which further reduces the optimality of the charging schedule.

As opposed to the charging station based concept, which aggregates the charging stations, the proposed electric vehicle based concept aggregates vehicles themselves. This enables optimal charging schedule for each electric vehicle, regardless where it is charged. On top of this, it resolves the communication issues as there is no need for electric vehicles to send their private data to charging stations. Another issue with the current literature is the lack of power constraints. This is related to charging capacities of vehicles on-board charger and charging points, as the lower of these two values is binding and, thus, both should be considered in the models. The electric vehicle charger aggregator concept requires vehicles to send the on-board charger capacity data to charging stations in order to determine their future flexibility volume, which is avoided with the electric vehicle battery concept. The final issue we identified are incomplete costs of charging as majority of the published papers do not consider grid fees or infrastructure costs. In the charger aggregator model, this infrastructure are vehicles themselves, which means they should send their costs to charging stations so an charger aggregator can decide on its charging schedule. Again, the proposed battery aggregator model requires charging stations, which are infrastructure in this case, to send their costs to vehicles and these costs are already public.

Charging station based system yields sub-optimal results for the vehicle owners. The proposed electric vehicle based system where vehicles take the leading role in electricity markets proved to be much more economically attractive for the owners. This is especially the case when volatility of electricity prices is high. In such case the electric vehicle based model results in 3.87 times lower overall costs for the three observed vehicles than the charging station based models. Opposed to the electric vehicle based model, the analyzed charging station based models cannot accurately anticipate the optimal arriving and departing state-of-energy and cannot exchange flexibility among stations. Also, the paper showed that insufficiently modeled constraints and costs can steer the scheduling results in a wrong direction leading to infeasible charging/discharging bids and higher actual operating costs. Analysis of accurate power constraints points out the value of higher installed power capacities both for on-board charger and external charging station equipment.

The proposed model and the presented results can be of significant value for EV aggregators when developing business models and can be applied to designing charging prices when approaching potential end-users. The initial results suggest that integrating the proposed EVBA approach could create substantial market advantage and result in higher profits as compared to the traditional EVCA approach.

The validation on a small test case is a first step into the EV-based smart e-mobility system research. It provides a proof that the EV-based system yields better results than the traditional approach, however

further investigation is needed to fully capture and demonstrate the significance of this improvement. Future research will focus on uncertainty in electric vehicle based models and participation of an electric vehicle battery aggregator in ancillary services markets and test the electric vehicle based concept on a large fleet.

#### CRedit authorship contribution statement

**Ivan Pavić:** Conceptualization, Methodology, Software, Investigation, Writing - original draft. **Hrvoje Pandžić:** Resources, Writing - review & editing, Supervision, Funding acquisition. **Tomislav Capuder:** Conceptualization, Resources, Supervision, Funding acquisition.

#### Declaration of Competing Interest

The authors declare that they have no known competing financial interests or personal relationships that could have appeared to influence the work reported in this paper.

#### Acknowledgement

This work has been supported in part by the European Structural and Investment Funds under project KK.01.2.01.0077 bigEVdata (IT solution for analytics of large sets of data on e-mobility).

#### References

- [1] European Parliament and European Council. Directive 2014/94/EU of the European Parliament and of the Council of 22 October 2014 on the deployment of alternative fuels infrastructure; 2014. [Online]. Available: <https://eur-lex.europa.eu/legal-content/EN/TXT/?uri=celex%3A32014L0094>.
- [2] Bobanac V, Pandzic H, Capuder T. Survey on electric vehicles and battery swapping stations: expectations of existing and future EV owners. In: 2018 IEEE International Energy Conference (ENERGYCON). IEEE; Jun 2018. p. 1–6. [Online]. Available: <https://ieeexplore.ieee.org/document/8398793/>.
- [3] Capuder T, Miloš Sprčić D, Zoričić D, Pandžić H. Review of challenges and assessment of electric vehicles integration policy goals: Integrated risk analysis approach. *Int J Electr Power Energy Syst* 2020;119:105894. [Online]. Available: <https://www.sciencedirect.com/science/article/abs/pii/S0142061519318174>.
- [4] Muratori M. Impact of uncoordinated plug-in electric vehicle charging on residential power demand. *Nat Energy* 2018;3(3):193–201.
- [5] Wolinetz M, Aksen J, Peters J, Crawford C. Simulating the value of electric-vehicle-grid integration using a behaviourally realistic model. *Nat Energy* 2018;3(2):132–9.
- [6] Xu Y, Çolak S, Kara EC, Moura SJ, González MC. Planning for electric vehicle needs by coupling charging profiles with urban mobility. *Nat Energy* 2018;3(6):484–93.
- [7] Pavić I, Capuder T, Kuzle I. Value of flexible electric vehicles in providing spinning reserve services. *Appl Energy* 2015;157:60–74.
- [8] Pavić I, Capuder T, Kuzle I. Low carbon technologies as providers of operational flexibility in future power systems. *Appl Energy* 2016;168:724–38.
- [9] Liu C, Chau KT, Wu D, Gao S. Opportunities and challenges of vehicle-to-home, vehicle-to-vehicle, and vehicle-to-grid technologies. *Proc IEEE* 2013;101(11):2409–27.



- [10] Monteiro V, Pinto JG, Afonso JL. Operation modes for the electric vehicle in smart grids and smart homes: present and proposed modes. *IEEE Trans Veh Technol* 2016;65(3):1007–20.
- [11] Majidpour M, Qiu C, Chu P, Pota HR, Gadh R. Forecasting the EV charging load based on customer profile or station measurement? *Appl Energy* 2016;163:134–41. [Online]. Available: <https://www.sciencedirect.com/science/article/abs/pii/S0306261915014348>.
- [12] Truchot C, Dubarry M, Liaw BY. State-of-charge estimation and uncertainty for lithium-ion battery strings. *Appl Energy* 2014;119:218–27. [Online]. Available: <https://www.sciencedirect.com/science/article/abs/pii/S0306261913010556>.
- [13] Xiong R, Cao J, Yu Q, He H, Sun F. Critical review on the battery state of charge estimation methods for electric vehicles. *IEEE Access* 2018;6:1832–43. [Online]. Available: <http://ieeexplore.ieee.org/document/8168251/>.
- [14] Romare M, Dahllöf L. The Life Cycle Energy Consumption and Greenhouse Gas Emissions from Lithium-Ion Batteries. *Tech. Rep.*; 2017.
- [15] Onat NC, Kucukvar M, Afshar S. Eco-efficiency of electric vehicles in the United States: A life cycle assessment based principal component analysis. *J Cleaner Prod* 2019;212:515–26. [Online]. Available: <https://www.sciencedirect.com/science/article/pii/S0959652618337600>.
- [16] European Environment Agency. Electric vehicles and the energy sector - impacts on Europe's future emissions. *Tech. Rep.*; 2016.
- [17] Erdinc O, Paterakis NG, Mendes TDP, Bakirtzis AG, Catalao JPS. Smart household operation considering bi-directional EV and ESS utilization by real-time pricing-based DR. *IEEE Trans Smart Grid* 2015;6(3):1281–91.
- [18] Wi Y-M, Lee J-U, Joo S-K. Electric vehicle charging method for smart homes/buildings with a photovoltaic system. *IEEE Trans Consum Electron* 2013;59(2):323–8.
- [19] Pal S, Kumar R. Electric vehicle scheduling strategy in residential demand response programs with neighbor connection. *IEEE Trans Industr Inf* 2018;14(3):980–8.
- [20] Rana R, Prakash S, Mishra S. Energy management of electric vehicle integrated home in a time-of-day regime. *IEEE Trans Transp Electr* 2018;4(3):804–16.
- [21] Naghibi B, Masoum MAS, Deilami S. Effects of V2H integration on optimal sizing of renewable resources in smart home based on Monte Carlo simulations. *IEEE Power Energy Technol Syst J* 2018;5(3):73–84.
- [22] Tushar MHK, Assi C, Maier M, Uddin MF. Smart microgrids: optimal joint scheduling for electric vehicles and home appliances. *IEEE Trans Smart Grid* 2014;5(1):239–50.
- [23] Paterakis NG, Erdinc O, Pappi IN, Bakirtzis AG, Catalao JPS. Coordinated operation of a neighborhood of smart households comprising electric vehicles, energy storage and distributed generation. *IEEE Trans Smart Grid* 2016;7(6):2736–47.
- [24] Amiroun MH, Kazemi A. A new model based on optimal scheduling of combined energy exchange modes for aggregation of electric vehicles in a residential complex. *Energy* 2014;69:186–98. [Online]. Available: <https://www.sciencedirect.com/science/article/abs/pii/S0306544214001972>.
- [25] Jin X, Wu J, Mu Y, Wang M, Xu X, Jia H. Hierarchical microgrid energy management in an office building. *Appl Energy* 2017;208:480–94. [Online]. Available: <https://www.sciencedirect.com/science/article/pii/S0306261917314150>.
- [26] Hou H, Xue M, Xu Y, Xiao Z, Deng X, Xu T, et al. Multi-objective economic dispatch of a microgrid considering electric vehicle and transferable load. *Appl Energy* 2020;262:114489. [Online]. Available: <https://www.sciencedirect.com/science/article/abs/pii/S0306261920300015>.
- [27] Melhem FY, Grunder O, Zakaria H, Nazih M. Optimization and energy management in smart home considering photovoltaic, wind, and battery storage system with integration of electric vehicles. *Can J Electr Comput Eng* 2017;40(2):128–38.
- [28] Kikusato H, Mori K, Yoshizawa S, Fujimoto Y, Asano H, Hayashi Y, et al. Electric vehicle charge-discharge management for utilization of photovoltaic by coordination between home and grid energy management systems. *IEEE Trans Smart Grid* 2018;10(3):3186–97.
- [29] Zhang R, Cheng X, Yang L. Energy management framework for electric vehicles in the smart grid: a three-party game. *IEEE Commun Mag* 2016;54(12):93–101.
- [30] Nguyen DT, Le LB. Joint optimization of electric vehicle and home energy scheduling considering user comfort preference. *IEEE Trans Smart Grid* 2014;5(1):188–99.
- [31] Wei W, Liu F, Mei S. Charging strategies of EV aggregator under renewable generation and congestion: a normalized Nash equilibrium approach. *IEEE Trans Smart Grid* 2016;7(3):1630–41.
- [32] Vagropoulos SI, Kyriazidis DK, Bakirtzis AG. Real-time charging management framework for electric vehicle aggregators in a market environment. *IEEE Trans Smart Grid* 2016;7(2):948–57.
- [33] Bessa RJ, Matos MA. Optimization models for EV aggregator participation in a manual reserve market. *IEEE Trans Power Syst* 2013;28(3):3085–95.
- [34] Wu H, Shahidehpour M, Alabdulwahab A, Abusorrah A. A game theoretic approach to risk-based optimal bidding strategies for electric vehicle aggregators in electricity markets with variable wind energy resources. *IEEE Trans Sustain Energy* 2016;7(1):374–85.
- [35] Bessa RJ, Matos MA, Soares FJ, Lopes JAP. Optimized bidding of a EV aggregation agent in the electricity market. *IEEE Trans Smart Grid* 2012;3(1):443–52.
- [36] Kaur K, Singh M, Kumar N. Multiobjective optimization for frequency support using electric vehicles: an aggregator-based hierarchical control mechanism. *IEEE Syst J* 2019;13(1):771–82.
- [37] Goebel C, Jacobsen H-A. Aggregator-controlled EV charging in pay-as-bid reserve markets with strict delivery constraints. *IEEE Trans Power Syst* 2016;31(6):4447–61.
- [38] Vagropoulos SI, Bakirtzis AG. Optimal bidding strategy for electric vehicle aggregators in electricity markets. *IEEE Trans Power Syst* 2013;28(4):4031–41.
- [39] Kara EC, Macdonald JS, Black D, Bérge M, Hug G, Kiliccote S. Estimating the benefits of electric vehicle smart charging at non-residential locations: a data-driven approach. *Appl Energy* 2015;155:515–25. [Online]. Available: <https://www.sciencedirect.com/science/article/abs/pii/S0306261915007059>.
- [40] Shafie-khah M, Heydarian-Forushani E, Golshan M, Siano P, Moghaddam M, Sheikh-El-Eslami M, et al. Optimal trading of plug-in electric vehicle aggregation agents in a market environment for sustainability. *Appl Energy* 2016;162:601–12. [Online]. Available: <https://www.sciencedirect.com/science/article/abs/pii/S0306261915013768>.
- [41] Hoogvliet T, Litjens G, van Sark W. Provision of regulating- and reserve power by electric vehicle owners in the Dutch market. *Appl Energy* 2017;190:1008–19. [Online]. Available: <https://www.sciencedirect.com/science/article/pii/S0306261917300077>.
- [42] Sarker MR, Dvorkin Y, Ortega-Vazquez MA. Optimal participation of an electric vehicle aggregator in day-ahead energy and reserve markets. *IEEE Trans Power Syst* 2016;31(5):3506–15.
- [43] Ortega-Vazquez MA, Bouffard F, Silva V. Electric vehicle aggregator/system operator coordination for charging scheduling and services procurement. *IEEE Trans Power Syst* 2013;28(2):1806–15.
- [44] Zhang Y, Cai L. Dynamic charging scheduling for EV parking lots with photovoltaic power system. *IEEE Access* 2018;6:56 995–7 005.
- [45] Zhang L, Li Y. A game-theoretic approach to optimal scheduling of parking-lot electric vehicle charging. *IEEE Trans Veh Technol* 2016;65(6):4068–78.
- [46] Zhang L, Li Y. Optimal management for parking-lot electric vehicle charging by two-stage approximate dynamic programming. *IEEE Trans Smart Grid* 2017;8(4):1722–30.
- [47] Awad ASA, Shaaban MF, EL-Fouly THM, El-Saadany EF, Salama MMA. Optimal resource allocation and charging prices for benefit maximization in smart PEV-parking lots. *IEEE Trans Sustain Energy* 2017;8(3):906–15.
- [48] Kuran MS, Carneiro Viana A, Iannone L, Kofman D, Mermoud G, Vasseur JP. A smart parking lot management system for scheduling the recharging of electric vehicles. *IEEE Trans Smart Grid* 2015;6(6):2942–53.
- [49] Akhavan-Rezai E, Shaaban MF, El-Saadany EF, Karray F. Online intelligent demand management of plug-in electric vehicles in future smart parking lots. *IEEE Syst J* 2016;10(2):483–94.
- [50] Mehrabi A, Kim K. Low-complexity charging/discharging scheduling for electric vehicles at home and common lots for smart households prosumers. *IEEE Trans Consum Electron* 2018;64(3):348–55.
- [51] Zheng Y, Song Y, Hill DJ, Meng K. Online distributed MPC-based optimal scheduling for EV charging stations in distribution systems. *IEEE Trans Industr Inf* 2019;15(2):638–49.
- [52] Zhou Y, Kumar R, Tang S. Incentive-based distributed scheduling of electric vehicle charging under uncertainty. *IEEE Trans Power Syst* 2019;34(1):3–11.
- [53] You P, Yang Z, Chow M-Y, Sun Y. Optimal cooperative charging strategy for a smart charging station of electric vehicles. *IEEE Trans Power Syst* 2016;31(4):2946–56.
- [54] Xiong Y, Wang B, Chu C-C, Gadh R. Vehicle grid integration for demand response with mixture user model and decentralized optimization. *Appl Energy* 2018;231:481–93. [Online]. Available: <https://www.sciencedirect.com/science/article/abs/pii/S0306261918314508>.
- [55] Heydarian-Forushani E, Golshan M, Shafie-khah M. Flexible interaction of plug-in electric vehicle parking lots for efficient wind integration. *Appl Energy* 2016;179:338–49. [Online]. Available: <https://www.sciencedirect.com/science/article/abs/pii/S0306261916309333>.
- [56] Seddig K, Jochem P, Fichtner W. Two-stage stochastic optimization for cost-minimal charging of electric vehicles at public charging stations with photovoltaics. *Appl Energy* 2019;242:769–81. [Online]. Available: <https://www.sciencedirect.com/science/article/abs/pii/S0306261919304301>.
- [57] Gough R, Dickerson C, Rowley P, Walsh C. Vehicle-to-grid feasibility: a techno-economic analysis of EV-based energy storage. *Appl Energy* 2017;192:12–23. [Online]. Available: <https://www.sciencedirect.com/science/article/abs/pii/S0306261917301149>.
- [58] Cao Y, Huang L, Li Y, Jermisittiparsert K, Ahmadi-Nezamabad H, Nojavan S. Optimal scheduling of electric vehicles aggregator under market price uncertainty using robust optimization technique. *Int J Electr Power Energy Syst* 2020;117:105628. [Online]. Available: <https://www.sciencedirect.com/science/article/abs/pii/S0142061518335518>.
- [59] Enervalis. Smart EV Charging – Enervalis. [Online]. Available: <https://www.enervalis.com/smart-ev-charging/>.
- [60] Wallbox. About Us — Wallbox. [Online]. Available: <https://wallbox.com/en/about-us/>.
- [61] OVO Smart Charger. OVO Smart Charger — Smart electrical vehicle charging. [Online]. Available: <https://www.ovoenergy.com/ev-everywhere/smart-charger>.
- [62] Greenflux. The Future of Smart Charging — Greenflux.com; 2019. [Online]. Available: <https://www.greenflux.com/>.
- [63] NewMotion. Charging Solutions for EV — NewMotion; 2019. [Online]. Available: <https://newmotion.com/the-future-of-ev-charging-with-v2x-technology>.
- [64] SEEV4-City. Operational Pilots, Interreg VB North Sea Region Programme. [Online]. Available: <https://northsearegion.eu/seev4-city/operational-pilots/>.
- [65] Parker. Parker — World's first cross-brand V2G demonstration conducted in Denmark; 2019. [Online]. Available: <https://parker-project.com/worlds-first-cross-brand-v2g-demonstration-conducted-in-denmark/>.
- [66] Pandžić H, Bobanac V. An accurate charging model of battery energy storage. *IEEE Trans Power Syst* 2019;34(2):1416–26.
- [67] Ortega-Vazquez MA. Optimal scheduling of electric vehicle charging and vehicle-to-grid services at household level including battery degradation and price uncertainty. *IET Gener Transm Distrib* 2014;8(6):1007–16.
- [68] Recalde Melo DF, Trippe A, Gooi HB, Massier T. Robust electric vehicle aggregation

- for ancillary service provision considering battery aging. *IEEE Trans Smart Grid* 2018;9(3):1728–38.
- [69] Ecker M, Nieto N, Käbitz S, Schmalstieg J, Blanke H, Warnecke A, et al. Calendar and cycle life study of Li(NiMnCo)O<sub>2</sub>-based 18650 lithium-ion batteries. *J Power Sources* 2014;248:839–51.
- [70] Grave K, Breitschopf B, Ordonez J, Wachsmuth J, Boeve S, Smith M, et al. Prices and costs of EU energy Final Report. European Commission. Tech. Rep.; 2016.
- [71] EV rapid charge cost comparison - Zap-Map. [Online]. Available: <https://www.zap-map.com/ev-rapid-charge-cost-comparison/>.
- [72] The jungle of charge tariffs in the Netherlands - Amsterdam University of Applied Sciences. [Online]. Available: <http://www.idolaad.com/shared-content/blog/rick-wolbertus/2016/charge-tariffs.html>.
- [73] RMI: What's the true cost of EV charging stations? — GreenBiz. [Online]. Available: <https://www.greenbiz.com/blog/2014/05/07/rmi-whats-true-cost-ev-charging-stations>.



## **Publication 5**

I. Pavić, H. Pandžić, and T. Capuder, “Electric Vehicle Aggregator as an Automatic Reserves Provider in the European Market Setting,” *IEEE Transactions on Power System*, vol. Under review, pp. 1–8, 2020. arXiv: 2012.11158



# Electric Vehicle Aggregator as an Automatic Reserves Provider under Uncertain Reserve Activation

I. Pavić, *Student Member, IEEE*, H. Pandžić, *Senior Member, IEEE* and T. Capuder, *Member, IEEE*

**Abstract**—Shift of the power system generation from the fossil to the variable renewables prompted the system operators to search for new sources of flexibility, i.e., new reserve providers. With the introduction of electric vehicles, smart charging emerged as one of the promising solutions. However, electric vehicle aggregators face the uncertainty both on the reserve activation and the electric vehicle availability. These uncertainties can have a detrimental effect on both the aggregators' profitability and users' comfort.

State-of-the art literature mostly neglects the reserve activation or its uncertainty. On top of that, they rarely model European markets which are different than those commonly addressed in the literature. This paper introduces a new method for modeling the reserve activation uncertainty based on the real historic data from the European power system. Three electric vehicle scheduling models were designed and tested: the deterministic, the stochastic and the robust. The results demonstrate that the current deterministic approaches inaccurately represent the activation uncertainty and that the proposed models that consider uncertainty, both the stochastic and the robust, substantially improve the results. Additionally, the sensitivity analysis for the robust model was performed and it demonstrates how a decision-maker can choose its level of conservativeness, portraying its risk-awareness.

**Index Terms**—Electric Vehicles, Electric Vehicle Aggregator, Frequency Containment Reserve, Frequency Restoration Reserve, Uncertainty

## I. INTRODUCTION

Electrification of the transport sector is underway and electric vehicles (EVs) are rapidly increasing their market share [1]. Large EV fleets can have an adverse effect on the overall power system if inadequately controlled, e.g. increasing the peak power and the balancing needs. The conventional power system operation is already affected by the heavy penetration of renewable energy sources and decommissioning of fossil power plants. Thus, new flexibility sources are needed to effectively balance the system. Smart EV charging [2] seems to be a promising solution due to the EVs' high storage capability [3] and availability during the day [4].

Balancing the European power systems is based on four types of reserves [5]: Frequency Containment (FCR), automatic (aFRR) and manual (mFRR) Frequency Restoration, and Replacement Reserve (RR). The FCR and aFRR are automatically activated reserves (activated upon a frequency deviation and an automatic generation control signal, respectively) with fast response and short but more frequent activation events.

The authors are with the University of Zagreb Faculty of Electrical Engineering and Computing (e-mails: ivan.pavic@fer.hr; hrvoje.pandzic@fer.hr; tomlislav.capuder@fer.hr).

Generally, there are two value streams when it comes to reserves, the capacity reservation and the activation fees. The reservation fee is paid for the availability of a unit to change its operating point, whereas the activation fee is paid for the actual delivery of that change [6]. Similar to stationary batteries [7], EVs are technically better suited for automatic reserves [8] and providing them can yield high revenues [9]. Therefore, in this paper we exclusively focus on FCR and aFRR.

Three sources of uncertainty can be linked to the EV energy and reserve provision algorithms: EVs' driving patterns, market prices and reserve activations (RA). Uncertainty on the EV behaviour negatively affects the EVs' availability to deliver the planned services and to respect the EV batteries' state-of-energy (SOE). This is usually modelled using behavior scenarios [10], [11], [12], [13] and often includes the second stage for performing re-dispatching measures [14], [15], [16], [17]. The second uncertainty stream are price uncertainties that are commonly addressed through price-taker models using price scenarios [10], [12], [13], [11] or robust models where prices are determined as a worst-case scenario for the market participant [20], [21]. Another approach are the price-maker models where the aggregated EV battery capacity is assumed to be large and the market price evolves within the model itself. In such models the participants are paid on the pay-as-bid basis [16], [18] or by the market clearing price [19].

The EV behavior and price uncertainties are, in general, well elaborated in the recent literature. However, there is a gap in the literature in addressing the RA uncertainty. Deterministic modeling of RA [13], [14], [17], [21], [22] can create problems to EV users as well as to their aggregators [23]. The EV users may suffer from a lower SOE than required for their next trip if the activated up reserve volume was higher than anticipated. An insufficient SOE translates into a decreased comfort level for the EV users and affects their willingness to participate in reserve provision [11]. On the other hand, if the EV drivers' needs are prioritized, the aggregators may suffer from insufficient energy volumes to back up their day-ahead (DA) plans. Aggregators may experience issues in the opposite direction as well. If down reserve is more frequently activated, the EVs' SOE will be higher than expected and they will not be able to follow their DA schedule. Inability to adhere to the agreed DA schedule causes additional balancing costs [5], whereas the inability to activate the scheduled reserve leads to penalization [17], [22], [24] and eventually disqualification from the reserve market participation [16]. RA uncertainty modeling is thus essential for adequate re-

serve market participation. One of the possible approaches is stochastic modeling of the RA, as pursued in [10], [11], [13], [24]. However, the randomly generated RA scenarios, instead of the ones based on actual operation data, may not appropriately address the RA uncertainty [10], [11], [24]. On the other hand, employment of publicly available data such as automatic generation control signals (US-style market [13]) or RA data from the European platforms (e.g. ENTSO-E [18]) as scenarios is more appropriate. Following this logic, the stochastic model in this paper is designed to utilize such data.

Robust formulation of uncertainty is another approach rarely used when considering the RA and, to the best of the authors knowledge, only one paper [21] pursues this idea. It considers RA as two values: the number of RA during the day (an integer value) accompanied with a binary value for each call indicating whether the reserve is fully activated or not activated at all. However, such modelling approach is more adequate for manual reserves, while automatic reserves require a more rigorous uncertainty set. Following this approach, our paper robustly designs the RA uncertainty of the automatic reserves.

We model two types of reserves (FCR and aFRR) simultaneously and perform a comparison between their scheduling. Contrary to the majority of papers that tackle only the US-style markets, we focus on modeling the uncertainty of automatic RA for an EV aggregator based on real data stemming from the European-style markets. Although European markets were already investigated in [16], [17], [18], none of these modeled two types of automatic reserves and none of these based the uncertainty modeling on publicly available RA data. Additionally, this paper, for the first time, models and compares the RA uncertainty using the stochastic and the robust approach. Thus, we summarize contribution of the paper as follows:

- 1) it statistically analyses the aFRR and FCR historical data to define the set of RA scenarios as well as uncertainty sets (US) for the RA,
- 2) it integrates a newly created scenario set and US of aFRR and FCR RA into an EV model and casts it as stochastic and robust linear programs,
- 3) it designs a data-driven robust optimization model for reserve and energy bidding of an EV fleet model with RA as the source of uncertainty;
- 4) it simulates a simultaneous provision of aFRR, FCR and DA energy and proves the efficiency and adequacy of the designed models as compared to the deterministic model.

The rest of the paper is organized as follows. Section II provides statistical analyses of RA and determines the input parameters for RA modeling for all observed approaches. The mathematical background is formulated and elaborated in Section III, case studies and results are presented in Section IV, while Section VI highlights the most important findings and concludes the paper.

## II. DEFINING RA UNCERTAINTY

We design three models to adequately address the RA: the deterministic model (DM), the stochastic model (SM) and the robust model (RM). They all require some kind of input parameters for the RA modeling. A statistical analysis of the

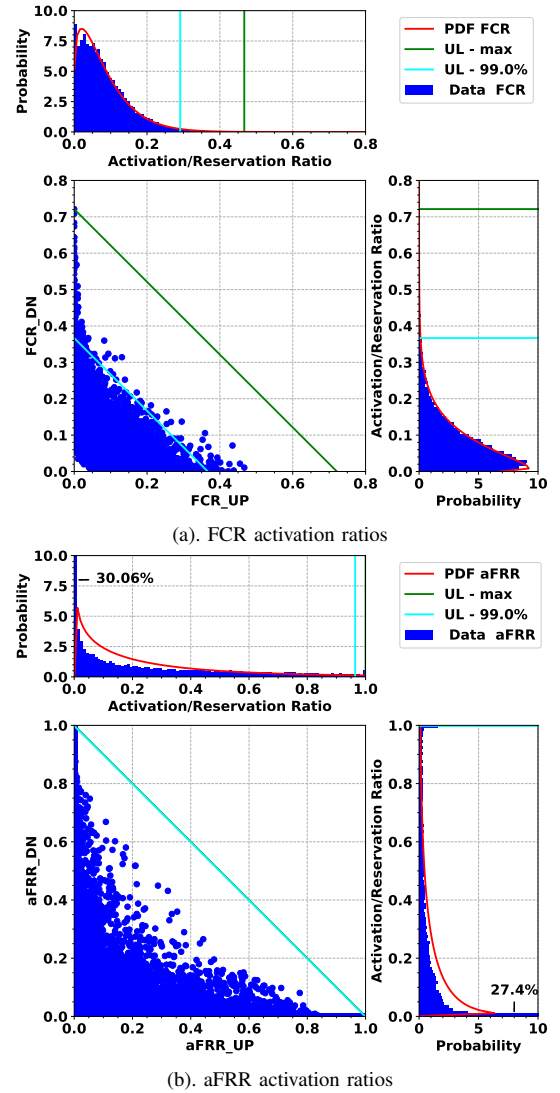

Fig. 1. Activation ratios – historical data (UL - Upper Limit)

RA behavior is required to gain those inputs. As the main analyzed parameter we choose the RA ratio, which is defined as the ratio of the Activated Reserve Energies (ARE) and Accepted Reserve Capacity (ARC) both for FCR and aFRR. The bids are taken from the RTE for the year 2018 [29]. For each half-hourly period (and each reserve type and direction) the RA quantities are calculated as:

$$\left( RA\_ratio_t = \frac{ARE_t}{ARC_t \cdot \Delta} \right)_{\{UP/DN\}_{FCR/aFRR}} \quad (A-1)$$

Visualization of the obtained results from the statistical analyses for FCR and aFRR is presented in Figure 1. These data are further used to determine the scalar inputs for the DM (annual average values equal in all timesteps), to select scenarios for the SM, and to obtain bounds for the US of the RM. Also, this dataset will be used to select RA scenarios for the ex-post validation of the models.

Probability distribution functions for up (UP) and down (DN) reserves are very similar for both the FCR and the aFRR (1). The down reserve has a slightly higher annual average

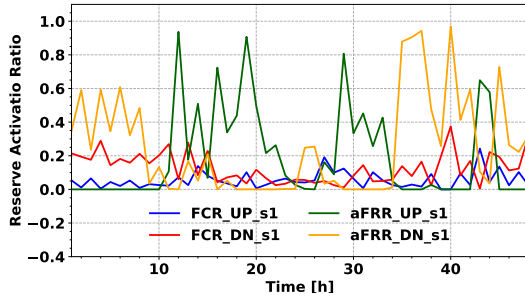

Fig. 2. RA scenario examples

value for both the FCR and the aFRR. Also, average values for both UP and DN directions are much higher for aFRR than for FCR. These average values are used in the DM as fixed inputs and are shown in the second column in Table I.

Scenarios for the SM are taken as the realized RA ratios for each reserve type and direction from Jan. 11-20, 2018 (10 in total). An ex-post validation is performed on scenarios from April 1, 2018 to July 9, 2018 (100 in total). The examples of the used scenarios are presented in Figure 2, indicating high uncertainty range. Each curve represents an RA ratio for one type of reserve and direction.

For the US of the RM two values are required, the maximum achieved RA ratios in each timestep and the daily sums of the RA ratios. The maximum RA ratios represent the energy that could be activated in one timestep, while the daily summations represent the energy that could be yielded through RA in one day. In the following paragraphs connection to the mathematical framework will be provided, but the equations themselves are explained in Section III.

The RA ratios for UP and DN reserves are dependent variables where a high RA value of one direction entails a low RA value of the other direction and vice versa (valid for both the FCR and the aFRR). This is modeled in (US-2) and shown as green (max) and cyan (99%) lines on graphs in Figures 1a and 1b. The same equation/line also bounds the individual RA ratios of the UP and DN reserves. The FCR RA ratio never reaches 1; the maximum ratio for UP RA is 0.47 and for DN RA 0.73. In 99% the FCR UP and DN RA ratios are lower or equal to 0.29 and 0.36, respectively. High aFRR RA ratios are also rare, but more frequent than in the case of FCR. In 99% of times, the UP and DN RA ratios are lower or equal to 0.96 and 1, respectively, as presented in Figure 1b with the teal-colored line. The maximum achieved RA ratios used for the US in the main case study are shown in Table I. Those in the third column are used for the subproblem (RI-4) and those in the fifth column are used for the subproblems (RI-5)–(RI-8).

The daily sums of the RA ratios (i.e. specific daily balancing energy) throughout the year are always within certain upper and lower limits, which are modeled in the US with constraints (US-3)–(US-6). The median of the daily sums for each reserve and direction are shown in Table I in column four for the main case study (Med). These data are used as both  $\Upsilon$  and  $\Gamma$  parameters for subproblem (RI-4). The minimum and maximum of the daily sums for each reserve and direction are shown in Table I in penultimate and ultimate columns, respectively. These data are later used as  $\Upsilon$  and  $\Gamma$  parameters

TABLE I  
RA RATIO INPUTS FOR DM AND RM

Model	DM	RM for (RI-4)		RM for (RI-5)–(RI-8)		
Parameter	A	$A^{\text{MAX}}$	$\Gamma = \Upsilon$	$A^{\text{MAX}}$	$\Upsilon$	$\Gamma$
Input	Mean	0.99%	Med	Max	Min	Max
UP_FCR	0.082	0.36	4	0.73	0.93	8.21
DN_FCR	0.085		3.8		1.10	16.64
UP_aFRR	0.198	1	9.13	1	2.10	21.31
DN_aFRR	0.218		9.70		2.62	20.51

for subproblems (RI-5)–(RI-8). The reason why we use two different US lies in the risk hedging requirements for two different objectives. Subproblem (RI-4) deals with financial risks associated with the total cost (soft constraint), whereas other subproblems deal with physical risks associated with the SOE equation (hard constraints). In this paper our focus is on limiting the battery operation to the feasible space of all possible scenarios, which is why the stricter US is utilized for subproblems (RI-5)–(RI-8). Along the main case study (Subsections V-A and V-B), the sensitivity analysis on US parameters is provided in Subsection V-C for the US input parameters of subproblems (RI-5)–(RI-8), while inputs for (RI-4) are held the same as in Table I.

### III. MATHEMATICAL FORMULATION

After presenting the nomenclature, we first develop the deterministic model, which is used as a baseline for the stochastic and the robust counterparts.

#### A. Nomenclature

##### 1) Sets and Indices:

$S$	Set of scenarios, indexed by $s \in \{1, N_s\}$ ,
$\mathcal{T}$	Set of timesteps, indexed by $t \in \{1, N_t\}$ ,
$\mathcal{V}$	Set of vehicles, indexed by $v \in \{1, N_v\}$ .

##### 2) Input Parameters:

$\Delta$	Duration of a timestep [h],
$\Lambda$	Maximum duration of the RA,
$A_{\{\text{UP/DN}\}_{\{\text{FCR/aFRR}\}}}$	Fixed up/down FCR/aFRR RA ratio,
$C_v^B$	Capital battery cost for EV $v$ [€],
$C_{v,t}^{\text{FCH}}$	Fast charging fee [€/kWh],
$C_t^{\text{DA}}$	Day-ahead market electricity price [€/kWh],
$B_v$	Battery capacity of EV $v$ [kWh],
$CA_{\{\text{UP/DN}\}_{\{\text{FCR/aFRR}\}}}$	Reserve activation fee [€/kWh],
$CR_{\{\text{UP/DN}\}_{\{\text{FCR/aFRR}\}}}$	Reserve capacity fee [€/kW/Δ],
$D_{\{1/2/3/4\}}^B$	Battery degradation coefficients,
$E_{v,t}^{\text{RUN}}$	Energy used for driving of EV $v$ [kWh],
$P_{v,t}^{\text{CP\_MAX}}$	Charging point maximum power limit [kW],
$P_{v,t}^{\text{FCH\_MAX}}$	Maximum power limit for fast charging [kW],
$P_{v,t}^{\text{OBC\_MAX}}$	Max. on-board-charger power for EV $v$ [kW],
$SOE_v^{\{\text{MIN/MAX}\}}$	Minimum/maximum SOE of EV $v$ [%],
$SOE_v^{\text{T0}}$	Initial SOE of EV $v$ [%],
$\eta_{\{\text{RUN/V2G}\}}$	EV driving/V2G discharging efficiency,
$\eta_{\{\text{FCH/SCH}\}}$	EV fast/slow charging efficiency.

##### 3) Variables:

$c^{\text{OTH}}$	Aggregator costs other than reserve activation [€],
$c^{\text{ACT}}$	Aggregator costs arising from reserve activation [€],
$c_{v,t}^{\text{DEG}}$	Degradation cost attributed to EV $v$ [€],
$e_{v,t}^{\{\text{BUY/SELL}\}_{\text{DA}}}$	Energy traded in the DA market [kWh],
$e_{v,t}^{\text{DCH}}$	Energy discharged from EV $v$ [kWh],
$e_{v,t}^{\{\text{FCH/SCH}\}}$	Energy fast/slow-charged to EV $v$ [kWh],

$e_{v,t}^{\text{DEG}}$	Energy used for degradation [kWh],
$e_{v,t}^{\text{OTH}}$	Accumulated en. other than from RA [MWh],
$e_{v,t}^{\text{ACT}}$	Accumulated energy from reserve RA [MWh],
$r_{v,t}^{\{\text{UP/DN}\}_{\{\text{FCR/aFRR}\}}}$	Capacity sold in reserve markets [MW],
$soe_{v,t}^{\text{EV}}$	State-of-energy of EV $v$ [kWh].

### B. Abbreviations

ARC	Accepted Reserve Capacity,
ARE	Activated Reserve Energie,
aFRR	automatic Frequency Restoration Reserve,
CP	Charging Point,
DA	Day Ahead,
DM	Deterministic Model,
EV	Electric Vehicle,
FCR	Frequency Containment Reserve,
OBC	On-Board-Charger,
OF	Objective Function,
RA	Reserve Activation,
RM	Robust Model,
SM	Stochastic Model,
SOE	State-Of-Energy,
US	Uncertainty Set,
V2G	Vehicle-to-Grid (grid discharge).

### C. Deterministic Model – DM

The RA is usually modeled as an annual average of activations, e.g. [13], [14], [17], [21], [22]. Similarly, our deterministic model (DM), which serves as the baseline, assumes average annual RA ratio of a particular reserve product. Therefore, the RA ratio is the same in all timesteps. The objective function (OF) includes five parts: cost/revenue from energy traded in the DA energy market, revenue from the power sold as FCR/aFRR capacity, V2G battery degradation cost, fast-charging cost and cost/revenue from energy withdrawn/injected as the activated FCR/aFRR (balancing energy). For brevity, the first four costs are assigned to  $c^{\text{OTH}}$  defined in eq. (D-2), while the costs associated to RA are assigned to  $c^{\text{ACT}}$  defined in eq. (D-3). Objective function is formulated as:

$$\min_{\Xi_0} (c^{\text{OTH}} + c^{\text{ACT}}); \quad (\text{D-1})$$

where:

$$c^{\text{OTH}} = \sum_{t=1}^{N_t} \left\{ \sum_{v=1}^{N_v} [e_{v,t}^{\text{BUY\_DA}} \cdot C_t^{\text{DA}} - e_{v,t}^{\text{SELL\_DA}} \cdot C_t^{\text{DA}} - r_{v,t}^{\text{UP\_FCR}} \cdot CR_t^{\text{UP\_FCR}} - r_{v,t}^{\text{DN\_FCR}} \cdot CR_t^{\text{DN\_FCR}} - r_{v,t}^{\text{UP\_aFRR}} \cdot CR_t^{\text{UP\_aFRR}} - r_{v,t}^{\text{DN\_aFRR}} \cdot CR_t^{\text{DN\_aFRR}} + c_{v,t}^{\text{DEG}} + e_{v,t}^{\text{FCH}} \cdot C_{v,t}^{\text{FCH}}] \right\}; \quad (\text{D-2})$$

$$c^{\text{ACT}} = \sum_{t=1}^{N_t} \left\{ \sum_{v=1}^{N_v} [-r_{v,t}^{\text{UP\_FCR}} \cdot A^{\text{UP\_FCR}} \cdot \Delta \cdot CA_t^{\text{UP\_FCR}} + r_{v,t}^{\text{DN\_FCR}} \cdot A^{\text{DN\_FCR}} \cdot \Delta \cdot CA_t^{\text{DN\_FCR}} - r_{v,t}^{\text{UP\_aFRR}} \cdot A^{\text{UP\_aFRR}} \cdot \Delta \cdot CA_t^{\text{UP\_aFRR}} + r_{v,t}^{\text{DN\_aFRR}} \cdot A^{\text{DN\_aFRR}} \cdot \Delta \cdot CA_t^{\text{DN\_aFRR}}] \right\}; \quad (\text{D-3})$$

Eq. (D-2) sums the DA market costs (consisting of energy purchase and sell as well as up and down FCR and aFRR capacity reservation), battery degradation and EV fast charging cost. On the other hand, eq. (D-3) contains only the RA costs,

where up RA is remunerated by the system operator (hence the minus sign), while the down RA must be paid to the system operator (hence the plus sign).

Objective function D-1 is subject to a number of constraints divided in a number of blocks for easier understanding.

$$e_{v,t}^{\text{BUY\_DA}}, e_{v,t}^{\text{SELL\_DA}}, r_{v,t}^{\text{UP\_FCR}}, r_{v,t}^{\text{DN\_FCR}}, r_{v,t}^{\text{UP\_aFRR}}, r_{v,t}^{\text{DN\_aFRR}} \geq 0; \quad (\text{D-4})$$

$$e_{v,t}^{\text{SELL\_DA}}/\Delta - e_{v,t}^{\text{BUY\_DA}}/\Delta + r_{v,t}^{\text{UP\_FCR}} + r_{v,t}^{\text{UP\_aFRR}} \leq \min(P_v^{\text{OBC\_MAX}}, P_{v,t}^{\text{CP\_MAX}}); \quad (\text{D-5})$$

$$e_{v,t}^{\text{BUY\_DA}}/\Delta - e_{v,t}^{\text{SELL\_DA}}/\Delta + r_{v,t}^{\text{DN\_FCR}} + r_{v,t}^{\text{DN\_aFRR}} \leq \min(P_v^{\text{OBC\_MAX}}, P_{v,t}^{\text{CP\_MAX}}); \quad (\text{D-6})$$

Eq. (D-4) sets the six market bidding variables as nonnegative. Eqs. (D-5) and (D-6) limit the total charging/discharging power available for bidding to the minimum of the On-Board Charger (OBC) capacity and the Charging Point (CP) capacity. In other words, (D-5) and (D-6) allocate the available power to the six market bidding variables appearing in these constraints.

$$soe_{v,t}^{\text{EV}} = SOE^{\text{T0}} \cdot B_v + e_{v,t}^{\text{OTH}} + e_{v,t}^{\text{ACT}}; \quad (\text{D-7})$$

$$e_{v,t}^{\text{OTH}} = \sum_{\tau=1}^t \left\{ e_{v,\tau}^{\text{BUY\_DA}} \cdot \eta^{\text{CH}} - e_{v,\tau}^{\text{SELL\_DA}}/\eta^{\text{DCH}} - E_{v,\tau}^{\text{RUN}}/\eta^{\text{RUN}} + e_{v,\tau}^{\text{FCH}} \cdot \eta^{\text{FCH}} \right\}; \quad (\text{D-8})$$

$$e_{v,t}^{\text{ACT}} = \sum_{\tau=1}^t \left\{ \Delta \cdot [\eta^{\text{CH}} \cdot (r_{v,\tau}^{\text{DN\_FCR}} \cdot A^{\text{DN\_FCR}} + r_{v,\tau}^{\text{DN\_aFRR}} \cdot A^{\text{DN\_aFRR}}) - 1/\eta^{\text{DCH}} \cdot (r_{v,\tau}^{\text{UP\_FCR}} \cdot A^{\text{UP\_FCR}} + r_{v,\tau}^{\text{UP\_aFRR}} \cdot A^{\text{UP\_aFRR}})] \right\}; \quad (\text{D-9})$$

Eq. (D-7) calculates the current SOE based on the initial SOE and the energy charged/discharged to/from the EV battery until the timestep  $t$ . Energy can be charged/discharged by the means of the DA market trading, driving, fast charging (D-8) and RA (D-9). Energy consumed for driving in one timestep originates from the input data of the EV driving/parking behaviour explained in Subsection IV-A. The amount of energy injected/extracted due to RA is modeled using parameters  $A^{\{\text{UP/DN}\}_{\{\text{FCR/aFRR}\}}} \in [0, 1]$ .

$$SOE^{\text{MIN}} \cdot B_v \leq soe_{v,t}^{\text{EV}} + e_{v,t+1}^{\text{BUY\_DA}} \cdot \eta^{\text{CH}} - e_{v,t+1}^{\text{SELL\_DA}}/\eta^{\text{DCH}} - \Lambda \cdot \Delta/\eta^{\text{DCH}} \cdot (r_{v,t+1}^{\text{UP\_FCR}} + r_{v,t+1}^{\text{UP\_aFRR}}) - E_{v,t+1}^{\text{RUN}}/\eta^{\text{RUN}} + e_{v,t+1}^{\text{FCH}} \cdot \eta^{\text{FCH}} \quad \forall t \in \mathcal{T}_{(t \neq N_t)}; \quad (\text{D-10})$$

$$SOE^{\text{MAX}} \cdot B_v \geq soe_{v,t}^{\text{EV}} + e_{v,t+1}^{\text{BUY\_DA}} \cdot \eta^{\text{CH}} - e_{v,t+1}^{\text{SELL\_DA}}/\eta^{\text{DCH}} + \Lambda \cdot \Delta \cdot \eta^{\text{CH}} \cdot (r_{v,t+1}^{\text{DN\_FCR}} + r_{v,t+1}^{\text{DN\_aFRR}}) - E_{v,t+1}^{\text{RUN}}/\eta^{\text{RUN}} + e_{v,t+1}^{\text{FCH}} \cdot \eta^{\text{FCH}} \quad \forall t \in \mathcal{T}_{(t \neq N_t)}; \quad (\text{D-11})$$

$$SOE^{\text{T0}} \cdot B_v \leq soe_{v,t}^{\text{EV}} \leq SOE^{\text{MAX}} \cdot B_v \quad \text{for } t = N_t; \quad (\text{D-12})$$

$$0 \leq e_{v,t}^{\text{FCH}} \leq P_{v,t}^{\text{FCH\_MAX}} \cdot \Delta; \quad (\text{D-13})$$

To ensure the EV batteries will be able to deliver the required reserves, their capacity is limited in eqs. (D-10) and (D-11) assuming their full activation. Eq. (D-10) acts as the lower bound to the SOE, where only the full up RA is considered. Similarly, eq. (D-11) acts as the upper bound to the SOE considering the full down RA. These two equations ensure that the SOE is feasible in each timestep even for the full RA. Eqs. (D-10) and (D-11) are applied up to timestep  $t < N_t$ .

In the final timestep the conventional SOE preservation eq. (D-12) is applied. The fast-charging is limited in (D-13).

$$e_{v,t}^{\text{DEG}} = e_{v,t}^{\text{SELL\_DA}}/\eta^{\text{DCH}} - e_{v,t}^{\text{BUY\_DA}} \cdot \eta^{\text{CH}} \\ + \Delta/\eta^{\text{DCH}} \cdot (r_{v,t}^{\text{UP\_FCR}} \cdot A^{\text{UP\_FCR}} + r_{v,t}^{\text{UP\_aFRR}} \cdot A^{\text{UP\_aFRR}}) \\ - \Delta \cdot \eta^{\text{CH}} \cdot (r_{v,t}^{\text{DN\_FCR}} \cdot A^{\text{DN\_FCR}} + r_{v,t}^{\text{DN\_aFRR}} \cdot A^{\text{DN\_aFRR}}); \quad (\text{D-14})$$

$$c_{v,t}^{\text{DEG}} \geq 0; \quad (\text{D-15})$$

$$c_{v,t}^{\text{DEG}} \cdot B_v \geq C_v^{\text{B}} \cdot [-D_1^{\text{B}} \cdot B_v \\ + D_2^{\text{B}} \cdot e_{v,t}^{\text{DEG}} + D_3^{\text{B}} \cdot (B_v - \text{soe}_{v,t}^{\text{EV}})]; \quad (\text{D-16})$$

$$c_{v,t}^{\text{DEG}} \cdot B_v \geq C_v^{\text{B}} \cdot D_4^{\text{B}} \cdot e_{v,t}^{\text{DEG}}. \quad (\text{D-17})$$

Li-ion batteries are prone to degradation, especially when cycled often. Incorporating degradation cost in the OF may reduce the battery charging/discharging actions not related to driving. The degradation is taken into account when discharging in the DA market or through RA in eq. (D-14). Eq. (D-15) defines  $c_{v,t}^{\text{DEG}}$  as a positive variable. Eqs. (D-16) and (D-17) bound and calculate the V2G discharging degradation cost. Those constraints are a linearized form of the degradation model from [25].

The above constraints (D-4)–(D-17) apply for  $\forall v \in \mathcal{V}$  and  $\forall t \in \mathcal{T}$ , except for eqs. (D-10)–(D-11), which are not valid for the last period, and for (D-12), which is valid for the last period only.

#### D. Stochastic Model – SM

The stochastic model (SM) differs from the DM in the definition of the RA ratio. While the DM uses a single value for all timesteps, the SM uses the RA ratio as a time-dependable parameter obtained from the historic data (details on how this data is used is explained in Section II). The RA parameters  $A_{s,t}^{\{\text{UP/DN}\}\{\text{FCR/aFRR}\}}$  and the associated variables  $g_s^{\text{RA}}, h_s^{\text{RA}}, \text{soe}_{s,v,t}^{\text{EV}}, e_{s,v,t}^{\text{DEG}}, c_{s,v,t}^{\text{DEG}}$  gain an additional index  $s$  in the SM as compared to the DM. The DM is thus reformulated using eqs. (S-1)–(S-4). Eqs. in (S-2) are identical as in the DM, while the SM instances of eqs. (S-3) and (S-4) are additionally valid  $\forall s \in \mathcal{S}$ .

Objective function:

$$\min_{\Xi_o} [P_s \cdot \sum_{s=1}^{N_s} (c_s^{\text{OTH}} + c_s^{\text{ACT}})]; \quad (\text{S-1})$$

$$\text{subject to:} \quad (\text{D-4}) - (\text{D-6}); \quad (\text{S-2})$$

$$(\text{D-3}), (\text{D-9}), (\text{D-14}), \quad \forall s \in \mathcal{S}; \quad (\text{S-3})$$

$$(\text{D-2}), (\text{D-7}) - (\text{D-8}), (\text{D-10}) - (\text{D-13}),$$

$$(\text{D-15}) - (\text{D-17}), \quad \forall s \in \mathcal{S}. \quad (\text{S-4})$$

#### E. Robust Model – RM

In the robust model (RM), the RA quantities are uncertain parameters ( $a_{v,\tau,t}^{\text{UP\_FCR}}, a_{v,\tau,t}^{\text{DN\_FCR}}, a_{v,\tau,t}^{\text{UP\_aFRR}}, a_{v,\tau,t}^{\text{DN\_aFRR}}$ ) whose boundaries are defined by the uncertainty set (US) defined in eqs. (US-1)–(US-8) with parameters resulting from the probabilistic analysis in Section II. The OF (RI-1) of the RM minimizes the total operating costs for the worst-case RA, i.e. maximizing the RA throughout the day, (RI-4)–(RI-8). Such min-max structure cannot be solved directly and an appropriate RM reformulation described in [30] was used.

The initial formulation of the RM is presented in Section III-E1, while the US is presented in Section III-E2. Using the duality theory, subproblems (RI-4)–(RI-8) are recast as duals and merged with the rest of the constraints creating the final problem presented in Section III-E3.

##### 1) Initial Formulation:

Objective function:

$$\min_{\Xi_o} (z) \quad (\text{RI-1})$$

is subject to:

$$(\text{D-2}), (\text{D-4}) - (\text{D-6}), (\text{D-8}), (\text{D-13}) - (\text{D-17}); \quad (\text{RI-2})$$

$$(\text{D-3}), (\text{D-9}); \quad (\text{RI-3})$$

$$\max_{\Xi_A} (c^{\text{ACT}}) \leq z - c^{\text{OTH}}; \quad (\text{RI-4})$$

$$\max_{\Xi_A} (-e_{v,t}^{\text{ACT}}) \leq B_v \cdot (\text{SOE}^{\text{T0}} - \text{SOE}^{\text{MIN}}) \\ - \Lambda \cdot \Delta/\eta^{\text{DCH}} \cdot (r_{v,t+1}^{\text{UP\_FCR}} + r_{v,t+1}^{\text{UP\_aFRR}}) + e_{v,t+1}^{\text{OTH}}; \quad (\text{RI-5})$$

$$\max_{\Xi_A} (e_{v,t}^{\text{ACT}}) \leq B_v \cdot (\text{SOE}^{\text{MAX}} - \text{SOE}^{\text{T0}})$$

$$- \Lambda \cdot \Delta \cdot \eta^{\text{CH}} \cdot (r_{v,t+1}^{\text{DN\_FCR}} + r_{v,t+1}^{\text{DN\_aFRR}}) - e_{v,t+1}^{\text{OTH}}; \quad (\text{RI-6})$$

$$\max_{\Xi_A} (e_{v,t}^{\text{ACT}}) \leq B_v \cdot (\text{SOE}^{\text{MAX}} - \text{SOE}^{\text{T0}}) - e_{v,t}^{\text{OTH}}; \quad (\text{RI-7})$$

$$\max_{\Xi_A} (-e_{v,t}^{\text{ACT}}) \leq e_{v,t}^{\text{OTH}}, \quad \text{for } t = N_t; \quad (\text{RI-8})$$

The OF of the RM (RI-1) minimizes the total cost of an EV fleet. Eqs. (RI-2) are the same as in the DM, while the uncertain parameters appear in constraints containing the RA variables, grouped under eq. (RI-3). Eqs. (RI-3) are similar as in the DM, but the fixed RA parameter is replaced with the uncertain one. The OF and each constraint containing the terms with uncertain parameters from (RI-3) are observed as independent maximization subproblems (RI-4)–(RI-8). The OF of the DM (D-1) is reformulated to its robust counterpart presented in eqs. (RI-1) and (RI-4). Eqs. (D-10)–(D-12) are adequately reformulated into eqs. (RI-5)–(RI-8). Note that the SOE balance equation (D-7) is already incorporated into the aforementioned eqs. and that SOE as a variable does not exist in the robust counterpart.

##### 2) Uncertainty Set:

Subproblems defined by eqs. (RI-4)–(RI-8) are valid  $\forall (a_{v,\tau,t}^{\text{UP\_FCR}}, a_{v,\tau,t}^{\text{DN\_FCR}}, a_{v,\tau,t}^{\text{UP\_aFRR}}, a_{v,\tau,t}^{\text{DN\_aFRR}}) \in \mathcal{A}$ , where  $\mathcal{A}$  is the following US:

$$\mathcal{A} = \{a_{v,\tau,t}^{\text{UP\_FCR}}, a_{v,\tau,t}^{\text{DN\_FCR}}, a_{v,\tau,t}^{\text{UP\_aFRR}}, a_{v,\tau,t}^{\text{DN\_aFRR}} \mid \\ a_{v,\tau,t}^{\text{UP\_FCR}}, a_{v,\tau,t}^{\text{DN\_FCR}} \geq 0; \quad (\text{US-1})$$

$$a_{v,\tau,t}^{\text{UP\_FCR}} + a_{v,\tau,t}^{\text{DN\_FCR}} \leq A^{\text{MAX\_FCR}} : \omega_{v,\tau,t}^{\text{FCR}}; \quad (\text{US-2})$$

$$\sum_{\tau=1}^t a_{v,\tau,t}^{\text{UP\_FCR}} \leq (\Gamma^{\text{UP\_FCR}} - 1) \cdot I_t + 1 : \mu_{v,t}^{\text{FCR}}; \quad (\text{US-3})$$

$$\sum_{\tau=1}^t a_{v,\tau,t}^{\text{UP\_FCR}} \geq \Upsilon^{\text{UP\_FCR}} \cdot I_t : \nu_{v,t}^{\text{FCR}}; \quad (\text{US-4})$$

$$\sum_{\tau=1}^t a_{v,\tau,t}^{\text{DN\_FCR}} \leq (\Gamma^{\text{DN\_FCR}} - 1) \cdot I_t + 1 : \psi_{v,t}^{\text{FCR}}; \quad (\text{US-5})$$

$$\sum_{\tau=1}^t a_{v,\tau,t}^{\text{DN\_FCR}} \geq \Upsilon^{\text{DN\_FCR}} \cdot I_t : \chi_{v,t}^{\text{FCR}}; \quad (\text{US-6})$$

$$(\text{US-1}) - (\text{US-6}) \text{ are analogous for aFRR.}; \quad (\text{US-7})$$

$$(\text{US-1}) - (\text{US-7}) \text{ are similar for (RI-4) - (RI-8)}. \quad (\text{US-8})$$

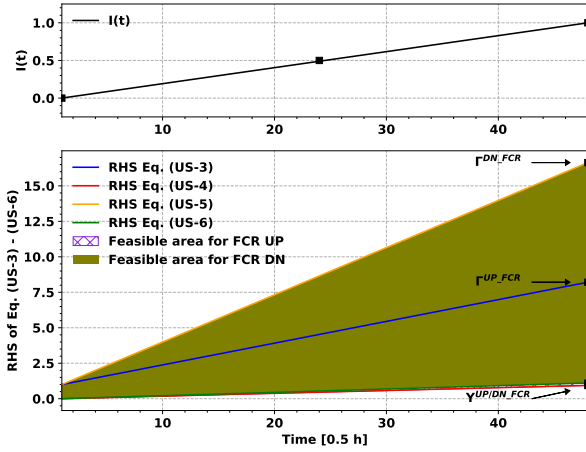

Fig. 3. Eqs. (US-3) – (US-6) right-hand-side visualization

**General explanation.** The US presented in eqs. (US-1)–(US-6) applies to the *FCR* service and the subproblem stated in (RI-5) as an exemplary formulation. The eqs. for aFRR are analogous to (US-1)–(US-6), as indicated in (US-7). For other subproblems the formulations are similar to eqs. (US-1)–(US-7), as indicated in (US-8). The form is the same and the differences are in the indexations of summations and dual variables. Those formulations are omitted due to succinctness of the paper. Please note that each of the five subproblems (RI-4)–(RI-8) contains one uncertainty set  $\mathcal{A}$  with their own four uncertain parameters ( $a_{v,\tau,t}^{\text{UP\_FCR}}$ ,  $a_{v,\tau,t}^{\text{DN\_FCR}}$ ,  $a_{v,\tau,t}^{\text{UP\_aFRR}}$ ,  $a_{v,\tau,t}^{\text{DN\_aFRR}}$ ). In total our master problem has  $5 \cdot 4 = 20$  uncertain parameters. Following this reasoning, each of the eqs. (US-1)–(US-6) can have different US parameters at the right-hand-side (RHS); the ones used in this paper are presented in Table I and have different dual variables.

**Explanation of the US formulation for *FCR* service and subproblem (RI-5).** Eq. (US-1) sets all uncertain parameters ( $a_{v,\tau,t}^{\text{UP\_FCR}}$ ,  $a_{v,\tau,t}^{\text{DN\_FCR}}$ ) as non-negative. Eq. (US-2) limits the sum of UP and DN *FCR* activation variables in each timestep. This equation is visualised as green or cyan line in Figures 1a and 1b. Values of  $A^{\text{MAX}}$  used in this paper are shown in Section II, Table I. This constraint limits both the individual UP and DN activations, as well as their summation. This stems from the historic data analysis that indicates if the activation in one direction is high, the activation in the other direction will be low and vice versa. Eqs. (US-3)–(US-6) consider the daily sums of the RA ratios (daily specific balancing energy). Eqs. (US-3) and (US-5) (eqs. (US-4) and (US-6)) state that total RA ratio up to a certain timestep must be lower (higher) than its limiting value on the right-hand-side. Parameters  $\Gamma$  and  $\Upsilon$  stand for the upper and lower limits of the daily sums of RA ratios and they are defined in Section II, Table I. Index  $t$  stands for the observed timestep, while the auxiliary index  $\tau$  iterates through all the previous timesteps to sum the RA variables. Parameter  $I_t$  on the right-hand-side represents a uniformly distributed range  $\in [0,1]$  through time. At timestep  $t = 1$  it equals 0, in  $t = N_t/2$  it equals 0.5, while in  $t = N_t$  it equals 1, as shown in Figure 3. The right-hand-side in  $t = N_t$  equals to  $\Gamma$  or  $\Upsilon$ , while they are linearly scaled with  $I_t$  in the previous timesteps. In  $t = 1$  those constraints are not binding

as  $I_t$  is 0. The RHS of eqs. (US-3)–(US-6) are shown in Figure 3, where the blue and red (yellow and green) lines represent limits in each step  $t$  for  $\sum_{\tau=1}^t a_{v,\tau,t}^{\text{UP\_FCR}}$  ( $\sum_{\tau=1}^t a_{v,\tau,t}^{\text{DN\_FCR}}$ ).

### 3) Final Formulation:

Objective function:

$$\min_{\Xi_0} (z) \quad (\text{RF-1})$$

subject to:

$$(\text{D-2}), (\text{D-4}) - (\text{D-6}), (\text{D-8}), (\text{D-13}) - (\text{D-17}); \quad (\text{RF-2})$$

$$(\text{D-3}), (\text{D-9}); \quad (\text{RF-3})$$

$$\begin{aligned} & A^{\text{MAX\_FCR}} \cdot \sum_{\tau=1}^t \omega_{v,\tau,t}^{\text{FCR}} \\ & + [(\Gamma^{\text{UP\_FCR}} - 1) \cdot I_{t+1}] \cdot \mu_{v,t}^{\text{FCR}} + \Upsilon^{\text{UP\_FCR}} \cdot I_t \cdot \nu_{v,t}^{\text{FCR}} \\ & + [(\Gamma^{\text{DN\_FCR}} - 1) \cdot I_{t+1}] \cdot \psi_{v,t}^{\text{FCR}} + \Upsilon^{\text{DN\_FCR}} \cdot I_t \cdot \chi_{v,t}^{\text{FCR}} \\ & A^{\text{MAX\_aFRR}} \cdot \sum_{\tau=1}^t \omega_{v,\tau,t}^{\text{aFRR}} \\ & + [(\Gamma^{\text{UP\_aFRR}} - 1) \cdot I_{t+1}] \cdot \mu_{v,t}^{\text{aFRR}} + \Upsilon^{\text{UP\_aFRR}} \cdot I_t \cdot \nu_{v,t}^{\text{aFRR}} \\ & + [(\Gamma^{\text{DN\_aFRR}} - 1) \cdot I_{t+1}] \cdot \psi_{v,t}^{\text{aFRR}} + \Upsilon^{\text{DN\_aFRR}} \cdot I_t \cdot \chi_{v,t}^{\text{aFRR}} \\ & \leq B_v \cdot (\text{SOE}^{\text{TO}} - \text{SOE}^{\text{MIN}}) \\ & - \Lambda \cdot \Delta / \eta^{\text{DCH}} \cdot (r_{v,t+1}^{\text{UP\_FCR}} + r_{v,t+1}^{\text{UP\_aFRR}}) + h_{v,t+1}^{\text{NRA}}; \end{aligned} \quad (\text{RF-4})$$

$$\begin{aligned} & \omega_{v,\tau,t}^{\text{FCR}} + \mu_{v,\tau}^{\text{FCR}} + \nu_{v,t}^{\text{FCR}} \geq \\ & \Delta / \eta^{\text{DCH}} \cdot r_{v,\tau}^{\text{UP\_FCR}} : a_{v,\tau,t}^{\text{UP\_FCR}}; \end{aligned} \quad (\text{RF-5})$$

$$\begin{aligned} & \omega_{v,\tau,t}^{\text{FCR}} + \psi_{v,t}^{\text{FCR}} + \chi_{v,t}^{\text{FCR}} \geq \\ & - \Delta \cdot \eta^{\text{CH}} \cdot r_{v,\tau}^{\text{DN\_FCR}} : a_{v,\tau,t}^{\text{DN\_FCR}}; \end{aligned} \quad (\text{RF-6})$$

$$\omega_{v,\tau,t}^{\text{FCR}}, \mu_{v,t}^{\text{FCR}}, \psi_{v,t}^{\text{FCR}} \geq 0; \quad (\text{RF-7})$$

$$\nu_{v,t}^{\text{FCR}}, \chi_{v,t}^{\text{FCR}} \leq 0; \quad (\text{RF-8})$$

$$(\text{RF-5})\text{--}(\text{RF-8}) \text{ are analogous for aFRR}; \quad (\text{RF-9})$$

$$(\text{RF-4})\text{--}(\text{RF-9}) \text{ are similar for (RI-4)–(RI-8)}. \quad (\text{RF-10})$$

**General explanation.** The final robust formulation (RF-1)–(RF-10) contains an exemplary subproblem (RI-5) and *FCR* service. Eqs. (RF-1)–(RF-3) are the same as in the RI formulation. Eqs. (RF-4)–(RF-8) are related to the exemplary subproblem and service. Eq. (RF-9) spreads the model over the aFRR dual constraints and they are the same as for the *FCR* reserve (only with the aFRR variables and parameters). Eq. (RF-10) spreads the model on subproblems (RI-4), (RI-6)–(RI-8). Equations for those subproblems are of the same form but with the differences in the indexations of summations and dual variables. Those formulations are omitted due to succinctness of the paper.

**Explanation of the final robust formulation for *FCR* service and subproblem (RI-5).** Eqs. (RF-4) represents a strong duality equation including both the *FCR* and aFRR services in both directions. At the left-hand-side (LHS) the dual variables are multiplied with their related uncertainty parameters, while the RHS is forwarded from eq. (RI-5). Dual constraints for uncertain parameters  $a_{v,\tau,t}^{\text{UP\_FCR}}$  and  $a_{v,\tau,t}^{\text{DN\_FCR}}$  are presented in eqs. (RF-5) and (RF-6), respectively. The LHS contains all the related dual variables and their linear combination, while the RHS stems from the objective function of subproblem (RI-5). Eqs. (RF-7) and (RF-8) set the dual variables as non-negative and non-positive, respectively. Those



constraints arise from the inequality directions from the eqs. (US-2)–(US-6).

Eq. (RF-4) applies  $\forall t \in \mathcal{T}$  and  $\forall v \in \mathcal{V}$ , while eqs. (RF-5)–(RF-8) additionally apply  $\forall \tau \in \mathcal{T}, \tau < t$ .

#### IV. CASE STUDIES

The case study employs three models: the DM with average annual RA, the SM with 10 ex-ante RA scenarios (scenario examples are given Figure 2) and the RM with the US based on the real balancing data. The outcome of the models are DA schedules, whose quality is assessed using one hundred historical RA scenarios in ex-post analysis.

##### A. Input Parameters

The EV driving/parking behaviour was consolidated from the European driving study [4], [27], and [28]. The data was restructured to represent 5-min EV driving/parking behaviour. Vehicle type and average trip speed were used as inputs to calculate the EV consumption while driving. Starting/finishing trip locations were used to assign instantaneous CP capacity, i.e. to choose the CP type. Three CP types were available: low (3.7 kW), medium (7.4 kW) and high (11 kW). Starting/finishing trip times were used to assign whether an EV is driving or parked. The 5-min timestamps were then summarized into half-hourly periods to match the half-hourly optimization time resolution. As a result, for each EV and each half-hourly period, two input parameters were created: EV driving consumption ( $E_{v,t}^{\text{RUN}}$  in eq. (D-7)) and maximum CP power ( $P_{v,t}^{\text{CP-MAX}}$  in eqs. (D-5) and (D-6)). The data-set for France was used with the total of 581 EVs divided into three types based on vehicle type (battery capacity, OBC size, fleet share): small (20 kWh, 3.7 kW, 30%), medium (40 kWh, 7.4 kW, 40%) and large (60 kWh, 11 kW, 30%). The total fleet capacity is 23.08 MWh, and the total OBC power is 4.26 MW. The EV battery capacity limits are  $SOE^{\text{T0}} = 0.6$ ,  $SOE^{\text{MAX}} = 1$ ,  $SOE^{\text{MIN}} = 0.2$ .

##### B. Characteristic Days

The models are tested on four characteristic days:

- *Day 1* – energy price curve with low daily volatility and low FCR capacity price,
- *Day 2* – energy price curve with low daily volatility and high FCR capacity price,
- *Day 3* – energy price curve with high daily volatility and low FCR capacity price,
- *Day 4* – energy price curve with high daily volatility and high FCR capacity price.

The prices are taken from the French electricity exchange and transmission system operator websites for 2018-2019 [29]. The aFRR price is the same in all four days as its price in France is regulated.

##### C. Case Studies Introduction

When the reserve is scheduled in the DA, its activation in real-time affects the SOE of a particular EV. If the RA at a certain timestep is such that it steers the SOE to its limits and disables the adherence of the planned DA schedule, the aggregator must redispatch this EV by trading in

subsequent intraday/balancing markets to backtrack the SOE to its DA-planned value. In reality, the SOE limits cannot be violated as any kind of charging or discharging would stop if the EV reaches its battery limits. However, in the ex-post analysis carried out in Section V the violation of the SOE limits is used as an indicator when the EV DA scheduling algorithm incorrectly models the RA uncertainty. The goal of the proposed algorithms is to ensure that even without trading in subsequent markets, or any other kind of redispatching, the RA does not cause infeasible SOE levels and inability to provide the promised services. Please note that converting the mentioned indicators to financial values or penalization would require detail modeling of the intraday and balancing markets, imbalance settlement and unsupplied reserve penalization fee, which would broaden the scope of the paper without the effect on the objective of this research, which is the exact modeling of reserve activation uncertainty. Therefore, we use the following terms as validation indicators of inadequate uncertainty modeling: minimum or maximum SOE of individual EV, number of EVs within the fleet with SOE outside its bounds, total energy outside the SOE bounds for the whole EV fleet.

#### V. RESULTS AND DISCUSSION

Using the US parameters from Table I the main analysis is performed to compare the three observed models. A detailed analysis of the daily schedules/profiles and EVs violating the constraints is shown in Section V-A. The relevant results are given as timeseries in Figures 4–6 for Day 1. The Section V-B expands the analysis on four characteristic days using the aggregated results presented in Table II.

Section V-C focuses only on RM and Day 1 to provide a sensitivity analysis on the input parameters for the US. The sensitivity analysis is done only for the US inputs of subproblems (RF-5)–(RF-8), while the inputs for (RF-4) are held fixed (the values from the Table I). The results are presented as bar graphs for different US parameters and shown in 7.

##### A. Day-ahead Plans – Day 1

Figures 4–6 show the results of the three models. Subfigures to the left show the DA schedules and subfigures to the right show how those plans affect the SOE constraints of the EV fleet. The DM schedules maximum aFRR (at higher price as compared to the FCR) in both directions plus it schedules a large amount of DA charging energy to compensate for the missing energy. Due to a high amount of the scheduled reserves, a high number of EVs end up with their SOE limits violated in both directions (up to 581) and by a significant margin (up to -164% and 210%). In Figure 4b) the solid lines denote SOE in % and the dashed lines represent the number of EVs outside the limits in the worst-case scenario *Max* and excluding the 10% of the worst scenarios *Q10*.

The SM adjusts the reserve schedule to its ex-ante scenarios and results in variable reserve schedules where both the FCR and the aFRR are utilized in both directions, as shown in Figure 5. The down reserve is scheduled more frequently to avoid charging in the DA energy market. Even though the aFRR reserve is better priced, the FCR is scheduled more

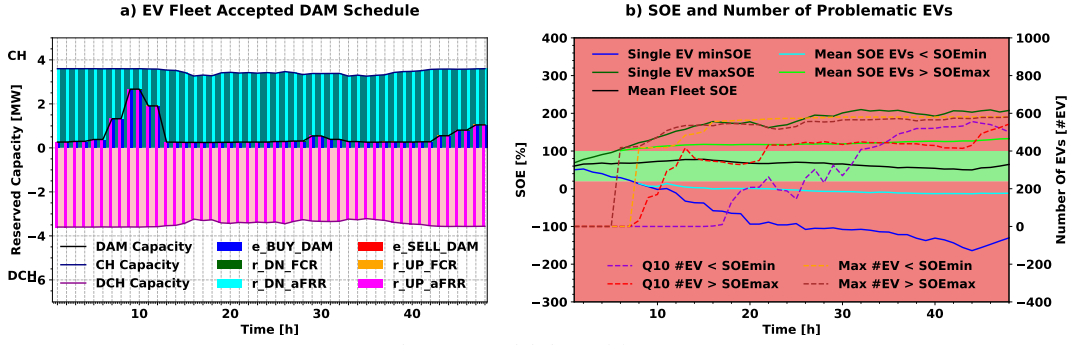

Fig. 4. Deterministic Model – Day 1

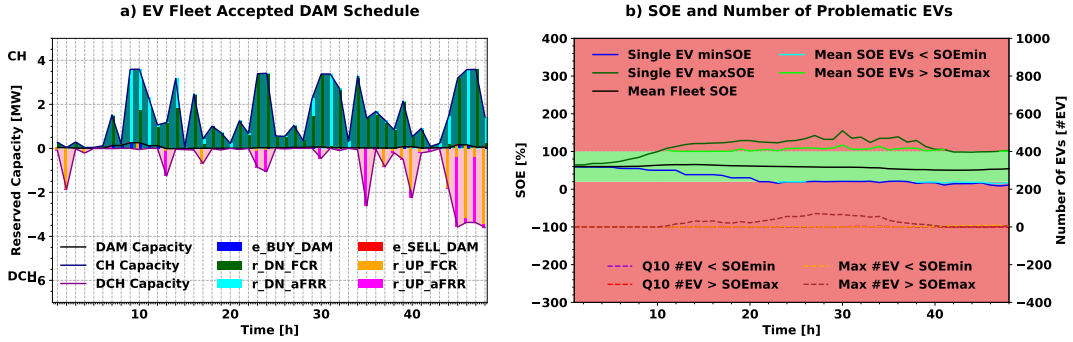

Fig. 5. Stochastic Model – Day 1

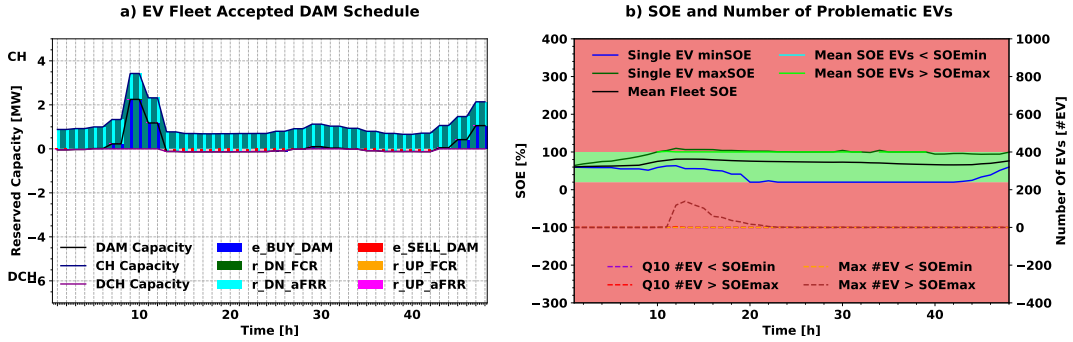

Fig. 6. Robust Model – Day 1

frequently since it is less stochastic. The number of EVs beneath the  $SOE^{\text{MIN}}$  level is negligible during the entire day, whereas during the daytime a certain amount of EVs can surpass  $SOE^{\text{MAX}}$  (up to 71 EVs and up to 155% of SOE).

The RM adjusts the reserve schedule to find a trade-off between the OF value and the worst-case RA. It schedules the reserve rather uniformly through the day and selects only aFRR in down direction (higher price than FCR), as presented in Figure 6. DA energy charging and discharging is utilized to create the optimal working point for each EV, i.e. to maximize reserve provision for the worst-case realization of uncertainty. There are almost no EVs surpassing  $SOE^{\text{MAX}}$ . The morning peak of such EVs is visible in Figure 6b), but their SOE is only slightly above  $SOE^{\text{MAX}}$  (110% as compared to 155% for the SM and 210% for the DM). The reason for this lies in the linear representation of  $I(t)$  to model the activated energy. None of the EVs have an SOE beneath  $SOE^{\text{MIN}}$  for the RM versus a negligible number for the SM (8 EVs down to -8.83%) and a significant number for the DM (556 EVs down

to -164%). It can be concluded that both the SM and the RM compromise between the revenue and the uncertainty but in their unique way and that the EVs rarely surpass their SOE limits.

### B. Summarized Results – All Days

The results shown in Table II are separated into three major segments, providing the statistics on: I) the realized costs, II) the EVs whose SOE is theoretically lower than  $SOE^{\text{MIN}}$ , III) the EVs whose SOE is theoretically higher than  $SOE^{\text{MAX}}$ . Shaded cells highlight the worst results for a specific reference day, while the best results are in bold text.

As seen in Figures 4–6, the DM provides maximum possible reserve at the expense of the provision infeasibility. Thus, it displays the lowest costs in segment I of Table II. *Min Cost* for the DM ranges from -2570 to -1860 €, while *Max Cost* is in between -290 and -30 €. The RM, due to its strict US on the SOE limits but loose US on the OF, provides the highest cost solution. *Min Cost* for the RM is always higher than -50 € and *Max Cost* is always higher than 340. However, the DM



TABLE II  
AGGREGATE RESULTS FOR TWO REFERENCE DAYS BASED ON 100 EX-POST SCENARIOS SIMULATION

Observed Results		Day 1			Day 2			Day 3			Day 4		
		DM	SM	RM	DM	SM	RM	DM	SM	RM	DM	SM	RM
I)	Min Cost [10 <sup>3</sup> €]	<b>-2.51</b>	-0.20	0.01	<b>-1.86</b>	-0.59	-0.05	<b>-2.57</b>	-0.21	0.04	<b>-1.87</b>	-0.60	-0.03
	Max Cost [10 <sup>3</sup> €]	<b>-0.07</b>	0.28	0.34	<b>-0.29</b>	0.09	0.38	<b>-0.03</b>	0.31	0.34	<b>-0.29</b>	0.12	0.37
II)	Min SOE [%]	-164.11	8.83	<b>20.00</b>	-37.78	4.99	<b>20.00</b>	-141.48	6.70	<b>20.00</b>	-36.81	4.76	<b>20.00</b>
	Max $\Sigma$ SOE < [MWh]	25.12	0.01	<b>0.00</b>	4.34	0.02	<b>0.00</b>	23.97	0.01	<b>0.00</b>	3.98	0.03	<b>0.00</b>
	Max #EV < [#]	581	8	<b>0</b>	523	21	<b>0</b>	581	7	<b>0</b>	520	26	<b>0</b>
III)	Max SOE [%]	209.89	154.97	<b>109.60</b>	190.26	176.93	<b>106.84</b>	213.27	149.01	<b>111.78</b>	188.53	181.31	<b>109.37</b>
	Max $\Sigma$ SOE > [MWh]	16.15	0.27	<b>0.15</b>	12.95	0.50	<b>0.31</b>	16.15	0.36	<b>0.22</b>	12.41	0.60	<b>0.10</b>
	Max #EV > [#]	580	<b>71</b>	139	572	<b>307</b>	420	580	<b>89</b>	170	570	457	<b>105</b>

would suffer greatly from the penalties related to the energy and reserve redispatching in the real time, whereas the RM would be mostly intact by them, i.e. it would be robust to the risks of not being able to provide the scheduled services. The SM is in between these two models, with *Min Cost* ranging from -200 to -600 € and *Max Cost* in between 90 and 310 €.

In segments II) and III) of Table II, *Min/Max* parameters refer to the worst realization of the observed parameter. In segment II), *Min SOE* corresponds to the lowest EV SOE realized in the ex-post analysis. The lowest *Min SOE* is always achieved for the DM with -164.11% in the worst characteristic day (Day 1). The SM yields better results as compared to the DM, but *Min SOE* is still underneath the allowable limits of 20% (for the worst reference day – Day 4 it is 4.76%). The lowest SOE in the RM is just at the lower SOE limit, i.e. 20%, meaning it does not violate the  $SOE^{\text{MIN}}$  limit in any of the observed reference days. *Max  $\Sigma$ SOE <* indicates the overall energy below  $SOE^{\text{MIN}}$  for the entire fleet in one timestep. The DM results in highest energy mismatch, going as high as 25 MWh of unsupplied energy, the SM is in range of several dozens kWh, and the RM is without such energy mismatch. *Max #EV <* indicates the number of EVs with SOE falls below  $SOE^{\text{MIN}}$  in the worst case. In the DM, all or almost all EVs (520-581) suffer from the SOE lower than  $SOE^{\text{MIN}}$ . The SM schedule results in up to 26 EVs below  $SOE^{\text{MIN}}$ , whereas the RM model does not suffer from this issue.

The parameters from segment III) in Table II are analogous to those from segment II), they just refer to the EVs' upper SOE limits. *Max SOE* is the highest for the DM (up to 213.27%), closely followed by the SM (up to 181.31%), and by far the lowest for the RM (up to 111.78%). High *Max  $\Sigma$  > SOE* values are achieved for the DM (up to 16.15 MWh), whereas the SM and RM are in the range of several hundreds kWh (RM lower for all characteristic days). Maximum number of EVs above  $SOE^{\text{MAX}}$  (*Max #EV >*) is extremely high for the DM (almost all EVs, 570-580), but also relatively high for the SM and RM as well (up to 457 and 420, respectively). For the first three characteristic days the SM even achieves better results than the RM. However, these numbers should be observed in relation to the maximum value of SOE. The high number of EVs above  $SOE^{\text{MAX}}$  for the RM means high number of EVs whose SOE is just slightly above  $SOE^{\text{MAX}}$ .

To conclude this results analysis, from the perspective of the SOE limits violation the RM provides the best solution closely followed by the SM. The DM is prone to high deviations in the actual realization of RA.

### C. Sensitivity Analysis - Day 1

Sensitivity analysis for the robust model US input parameters was performed for Day 1. Five test US are defined for subproblems (RF-5)–(RF-8) for the daily sums of the US parameters ( $\Upsilon$  and  $\Gamma$ ):

- Q0 - max/min data, the same as in Table I,
- Q1 - neglecting 1% of the worst activations,
- Q5 - neglecting 5% of the worst activations,
- Q10 - neglecting 10% of the worst activations,
- Q25 - neglecting 25% of the worst activations.

The maximum achieved RA ratio ( $A^{\text{MAX}}$ ) for each test US was held fixed as in Table I. All US inputs for subproblem (RF-4) are also held fixed for each test US as in Table I.

The goal of this analysis is to check whether the US constraints can be loosened to increase profit by providing more reserve but without sacrificing the feasibility of the EV conditions in the real-time. Figure 7 shows four types of indicators: min/max individual SOE (right axis in %) and min/max fleet-wise energy exceeding the SOE limits (left axis in MWh).

The Q0 UC shows a conservative solution where the entire range of uncertainty is considered and no infeasible SOE can appear in real-time (the daily profile is visible on Figure 6). If a portion of uncertainty is neglected, more issues appear in the real-time. By neglecting more uncertainty, more potential issues arise, as seen for cases Q1–Q25 in Figure 7. For this characteristic day even the results for Q10 seem sufficiently risk-free. Even if we neglect 25% of uncertainty, as in Q25, the results are still more resistant to uncertainty than in the DM. On the other side, neglecting uncertainty leads to more allocated reserves, meaning that profits can be poured into the aggregators pockets. The scheduling result for the Q10 test US is shown in Figure 8. Compared to Q0 (Figure 6), Q10 allocates more reserve. In average, the Q0 US schedules  $2.96 \times 10^{-4}$  MW aFRR UP and 1.62 MW aFRR DN, while the Q10 US schedules 0.13 MW aFRR UP and 2.86 MW aFRR DN reserve.

The value of the robust model is that the decision maker can choose its preferred level of conservativeness. A risk-prone aggregator can take liberal decisions gambling with the real-world conditions such as Q25, while the risk-averse will be satisfied with Q0 or Q1 input setup.

## VI. CONCLUSION

The paper brings a novel approach to modelling uncertainty of scheduling the automatic reserves activation (both aFRR and FCR) in European markets. It proposes stochastic- and

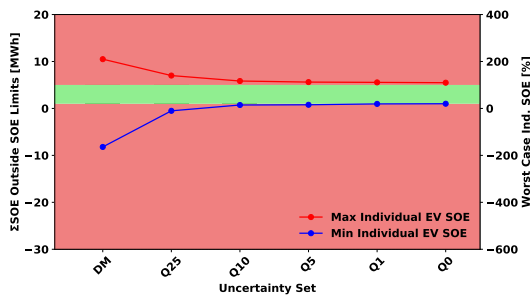

Fig. 7. Comparison of Validation Indicators for Tested Cases

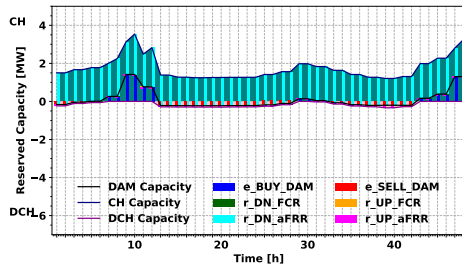

Fig. 8. EV Accepted DA Schedule for Q10

robust-based optimization models, where scenarios and uncertainty sets are based on an analysis of the real-world historical data. The existing deterministic model fails to properly accommodate the uncertain aspects of the reserve activation. The presented case study clearly demonstrates the advantages of the proposed approaches.

Although claiming high DA benefits, the deterministic model results in extreme individual violations of the EVs' battery SOE limits, ranging from -160% to above 200% SOE. Additionally, it results in high fleet-level deviations, from 25 MWh above  $SOE^{MAX}$  to 15 MWh below  $SOE^{MIN}$ . These deviations would, in reality, manifest as an inability to provide the scheduled DA energy, activated reserve energy or driving energy. The stochastic and robust formulations decrease the risks related to infeasible reserve activations. Minimum and maximum individual SOE levels achieved in the stochastic model are 4.76% and 181.31% of SOE and in the robust model 20% and 111.78% SOE. At the fleet level, energy levels below  $SOE^{MIN}$  are negligible, while levels above  $SOE^{MAX}$  are in the range of dozens of kWh. Both formulations are technology-agnostic and can be implemented in other algorithms (redispatch measures, other markets, adaptive robust algorithms, etc.) and paired with price, behavior or bid acceptance uncertainties. However, the robust model is more flexible and there are many improvements to be made on top of the the features presented in this paper, e.g. it can be further tailored for specific needs tightening or relaxing specific US parameters.

## REFERENCES

- [1] International Energy Agency, "Global EV Outlook 2019," Technical Report, 2019.
- [2] I. Pavić, T. Capuder, and I. Kuzle, "Low carbon technologies as providers of operational flexibility in future power systems," *Appl. Energy*, vol. 168, pp. 724–738, Apr. 2016.
- [3] International Renewable Energy Agency, Innovation landscape brief: Electric-vehicle smart charging, Technical Report, 2019.
- [4] G. Pasaoglu, D. Fiorello, A. Martino, G. Scarcella, A. Alemanno, A. Zubaryeva, an C. Thiel, "Driving and parking patterns of European car drivers - a mobility survey," European Commission Report, 2012.
- [5] ENTSO-E, "ENTSO-E Balancing Report," 2020.
- [6] ACER, "ACER Market Monitoring Report 2019 – Electricity Wholesale Markets Volume," ACER Market Monitoring Report 2018 — Electricity Wholesale Markets Volume, 2019.
- [7] J. Figgner *et al.*, "The development of stationary battery storage systems in Germany — A market review," *J. Energy Storage*, vol. 29, p. 101153, Jun. 2020.
- [8] Ramboll, "Ancillary Services From New Technologies," Technical Report, 2019.
- [9] J. Engels, "Integration of Flexibility from Battery Storage in the Electricity Market," PhD Thesis, 2020.
- [10] M. Alipour *et al.*, "Stochastic scheduling of aggregators of plug-in electric vehicles for participation in energy and ancillary service markets," *Energy*, vol. 118, pp. 1168–1179, Jan. 2017.
- [11] M. Shafie-Khah, M. P. Moghaddam, M. K. Sheikh-El-Eslami, and J. P. S. Catalao, "Optimised performance of a plug-in electric vehicle aggregator in energy and reserve markets," *Energy Convers. Manag.*, vol. 97, pp. 393–408, Jun. 2015.
- [12] I. Momber *et al.*, "Risk averse scheduling by a PEV aggregator under uncertainty," *IEEE Trans. Power Syst.*, vol. 30, no. 2, pp. 882–891, Mar. 2015.
- [13] S. I. Vagropoulos and A. G. Bakirtzis, "Optimal bidding strategy for electric vehicle aggregators in electricity markets," *IEEE Trans. Power Syst.*, vol. 28, no. 4, pp. 4031–4041, 2013.
- [14] P. Sanchez-Martin, S. Lumberras, and A. Alberdi-Alen, "Stochastic programming applied to ev charging points for energy and reserve service markets," *IEEE Trans. Power Syst.*, vol. 31, no. 1, pp. 198–205, Jan. 2016.
- [15] R. J. Bessa and M. A. Matos, "Optimization models for EV aggregator participation in a manual reserve market," *IEEE Trans. Power Syst.*, vol. 28, no. 3, pp. 3085–3095, 2013.
- [16] C. Goebel and H. A. Jacobsen, "Aggregator-Controlled EV Charging in Pay-as-Bid Reserve Markets with Strict Delivery Constraints," *IEEE Trans. Power Syst.*, vol. 31, no. 6, pp. 4447–4461, Nov. 2016.
- [17] P. Hasanpor Divshali and C. Evens, "Optimum Operation of Battery Storage System in Frequency Containment Reserves Markets," *IEEE Trans. Smart Grid*, vol. 11, no. 6, pp. 4906–4915, Nov. 2020.
- [18] M. Merten *et al.*, "Bidding strategy for battery storage systems in the secondary control reserve market," *Appl. Energy*, vol. 268, p. 114951, 2020.
- [19] K. Pandžić, I. Pavić, I. Androćec, and H. Pandžić, "Optimal Battery Storage Participation in European Energy and Reserves Markets," *Energies*, 2020.
- [20] G. Liu, Y. Xu, and K. Tomsovic, "Bidding strategy for microgrid in day-ahead market based on hybrid stochastic/robust optimization," *IEEE Trans. Smart Grid*, vol. 7, no. 1, pp. 227–237, Jan. 2016.
- [21] M. Kazemi *et al.*, "Operation Scheduling of Battery Storage Systems in Joint Energy and Ancillary Services Markets," *IEEE Trans. Sust. Energy*, vol. 8, no. 4, pp. 1726–1735, Oct. 2017.
- [22] M. R. Sarker, Y. Dvorkin, and M. A. Ortega-Vazquez, "Optimal participation of an electric vehicle aggregator in day-ahead energy and reserve markets," *IEEE Trans. Power Syst.*, vol. 31, no. 5, pp. 3506–3515, Sept. 2016.
- [23] I. Pavić, H. Pandžić, T. Capuder, "Electric Vehicles as Frequency Containment Reserve Providers," in *Proceedings of IEEE International Energy Conference (ENERGYCON)*, Gammarth, Tunisia, Oct. 2020.
- [24] B. Han *et al.*, "Day-ahead electric vehicle aggregator bidding strategy using stochastic programming in an uncertain reserve market," *IET Gener. Transm. Distrib.*, vol. 13, no. 12, pp. 2517–2525, Jun. 2019.
- [25] M. A. Ortega-Vazquez, "Optimal scheduling of electric vehicle charging and vehicle-to-grid services at household level including battery degradation and price uncertainty," *IET Gener. Transm. Distrib.*, vol. 8, no. 6, pp. 1007–1016, June 2014.
- [26] RTE, "RTE Customer's area - Volumes and prices." [Online]. Available: <https://clients.rte-france.com> [Accessed: 22-Jan-2019].
- [27] C. Thiel, A. Alemanno, G. Scarcella, A. Zubareyeva, and G. Pasaoglu, "Attitude of European car drivers towards electric vehicles: a survey," JRC Report, 2012.
- [28] G. Pasaoglu *et al.*, "Projections for EV Load Profiles in Europe Based on Travel Survey Data Contact information," JRC Report, 2013.
- [29] "RTE Customer's area - Volumes and prices." [Online]. Available: [https://clients.rte-france.com/lang/an/visiteurs/vie/mecanisme/volumes\\_prix/equilibrage.jsp](https://clients.rte-france.com/lang/an/visiteurs/vie/mecanisme/volumes_prix/equilibrage.jsp). [Accessed: 22-Jan-2019].
- [30] J. M. Morales *et al.*, *Integrating Renewables in Electricity Markets*, vol. 205. Boston, MA: Springer US, 2014.



## Conference Papers

### Published and Presented

- [Pub6] I. Pavić, T. Capuder, N. Holjevac, and I. Kuzle, “Role and impact of coordinated EV charging on flexibility in low carbon power systems,” in *2014 IEEE International Electric Vehicle Conference (IEVC)*, IEEE, Dec. 2014, pp. 1–8, ISBN: 978-1-4799-6075-0. DOI: 10.1109/IEVC.2014.7056172.
- [Pub7] I. Pavić, T. Capuder, and I. Kuzle, “Defining the Role of Traditional and Low Carbon Technologies in Providing Flexibility for Future Power Systems Operation,” in *Digital Proceedings of the 10th Conference on Sustainable Development of Energy, Water and Environment Systems – SDEWES*, 2015.
- [Pub8] T. Martinsen, N. Holjevac, B. A. Bremdal, I. Kuzle, J. M. Guerrero, T. Dragičević, I. Pavić, and Q. Shafiee, “Improved Grid Operation Through Power Smoothing Control Strategies Utilizing Dedicated Energy Storage at an Electric Vehicle Charging Station,” in *CIREN Workshop Helsinki*, 2016, pp. 1–4.
- [Pub9] I. Pavić, N. Holjevac, M. Zidar, I. Kuzle, and A. Nešković, “Transportation and power system interdependency for urban fast charging and battery swapping stations in Croatia,” in *2017 40th International Convention on Information and Communication Technology, Electronics and Microelectronics, MIPRO 2017 - Proceedings*, 2017, ISBN: 9789532330922. DOI: 10.23919/MIPRO.2017.7973652.
- [Pub10] I. Pavić, T. Capuder, N. Holjevac, and I. Kuzle, “Utjecaj električnih vozila na razvoj prijenosnog sustava,” in *2017 40th International Convention on Information and Communication Technology, Electronics and Microelectronics, MIPRO 2017 - Proceedings*, Opatija, 2017.
- [Pub11] I. Pavić, T. Capuder, and I. Kuzle, “Fast charging stations — Power and ancillary services provision,” in *2017 IEEE Manchester PowerTech*, IEEE, Jun. 2017, pp. 1–6, ISBN: 978-1-5090-4237-1. DOI: 10.1109/PTC.2017.7981190.
- [Pub12] I. Pavić, T. Capuder, I. Kuzle, and H. Pandžić, “Analiza aspekata fleksibilnosti budućeg elektroenergetskog sustava s integriranim električnim vozilima,” in *13. savjetovanje HRO CIGRÉ*, 2017, pp. 1–10.
- [Pub13] M. Zidar, I. Pavić, N. Holjevac, D. Jakšić, T. Radočaj, and I. Kuzle, “Integracija infrastrukture za punjenje električnih vozila u distribucijsku mrežu Karlovca,” in *13. savjetovanje HRO CIGRÉ*, 2017, pp. 1–8.

- [Pub14] I. Pavić, T. Capuder, and H. Pandžić, “Profit margin of electric vehicle battery aggregator,” in *2018 IEEE International Energy Conference (ENERGYCON)*, IEEE, Jun. 2018, pp. 1–6, ISBN: 978-1-5386-3669-5. DOI: 10.1109/ENERGYCON.2018.8398790.
- [Pub15] I. Pavić, H. Pandžić, and T. Capuder, “Electric vehicles as frequency containment reserve providers,” in *6th IEEE International Energy Conference, ENERGYCon 2020*, Institute of Electrical and Electronics Engineers Inc., Sep. 2020, pp. 911–917, ISBN: 9781728129563. DOI: 10.1109/ENERGYCon48941.2020.9236585.
- [Pub16] I. Pavić, H. Pandžić, and T. Capuder, “Tight Robust Formulation for Uncertain Reserve Activation of an Electric Vehicle Aggregator,” in *2021 IEEE PowerTech*, Madrid, 2021, pp. 1–6.

### **Upcoming Conference/Under Review**

- [Pub17] I. Pavić, T. Capuder, and H. Pandžić, “Istodobni nastup na tržištima energije i rezervi - utjecaj nesigurnosti aktivacije rezerve,” in *15. savjetovanje HRO CIGRE*, 2021, p. 10.

## Publication 6

I. Pavić, T. Capuder, N. Holjevac, and I. Kuzle, “Role and impact of coordinated EV charging on flexibility in low carbon power systems,” in *2014 IEEE International Electric Vehicle Conference (IEVC)*, IEEE, Dec. 2014, pp. 1–8, ISBN: 978-1-4799-6075-0. DOI: 10.1109/IEVC.2014.7056172

# Role and Impact of Coordinated EV Charging on Flexibility in Low Carbon Power Systems

Ivan Pavić, *Student Member, IEEE*, Tomislav Capuder, *Student Member, IEEE*,  
Ninoslav Holjevac\*, *Student Member, IEEE* and Igor Kuzle, *Senior Member, IEEE*  
University of Zagreb Faculty of Electrical Engineering and Computing, Zagreb, Croatia  
Corresponding authors email: ninoslav.holjevac@fer.hr

**Abstract** — The paper analyses the impact of Electric Vehicle (EV) integration into different power systems and their flexibility potential in mitigating the uncertainty and variability of renewable energy sources (RES) generation. The problem is cast as Mixed Integer Linear Programming (MILP) unit commitment, modelling different generation mix/technologies over a number of scenarios. The results, as expected, show that different EV charging strategies have different impacts on power system operation and unit scheduling. In addition, the analyses support the premises that the greater number of EVs, with coordinated charging strategies, can have environmental benefits in terms of reducing CO<sub>2</sub> emissions in addition to reducing wind curtailment and system operation costs. These benefits are more obvious in low flexible power systems characterized by dominantly thermal power plants, while they are less pronounced in balanced hydro thermal systems.

**Keywords**—electric vehicles; renewable energy sources integration; mixed integer linear programming (MILP); power generation scheduling; spinning reserve; power system flexibility

## NOTATION

The notation used is listed below for quicker reference.

### Parameters

$\Delta$	Time period [h]
$\rho$	Frequency response slope
$\eta_h$	Efficiency of hydro power plants [%]
$\eta_{hp}$	Pumping efficiency of pump-storage [%]
$A$	Fixed cost of thermal units [\$/h]
$A_h$	Fixed cost of hydro units [\$/h]
$B$	Variable cost of thermal units [\$/MWh]
$B_h$	Variable cost of hydro units [\$/MWh]
$C_{shed}$	Load shedding penalties [\$/MWh]
$C_{shut}$	Shut-down cost [\$/h]
$C_{start}$	Start-up cost [\$/h]
$C_{over}$	Generation shedding penalties [\$/MWh]
$E_{mc}$	Carbon emissions penalties [\$/kgCO <sub>2</sub> ]
$E_{mr}$	Carbon emissions rate [kgCO <sub>2</sub> /MWh]
$E_{mrstart}$	Start-up carbon emissions rate [kgCO <sub>2</sub> ]
$F_{dn}$	Total downward frequency response [MW]
$F_{up}$	Total upward frequency response [MW]
$G$	Total number of thermal units of type i
$G_h$	Total number of hydro units of type i
$H$	Hydro power plant head [m]
$I$	Hydro power plant inflow [m <sup>3</sup> /s]

$k_v$	Reservoir water loss coefficient [%]
$N_i, N_{ih}$ and $N_{EV}$	Number of thermo, hydro and EV types
$n_{arr}$	Number of EVs arriving to the grid
$n_g$	Number of EVs connected to the grid
$n_{leav}$	Number of EVs leaving the grid
$P_{evmax}, P_{evmin}$	Maximum and minimum EVs charge, discharge [MW]
$P_{MAX}, P_{MIN}$	Generation limits of thermal PP [MW]
$P_{MAXh}, P_{MINh}$	Generation limits of hydro PP [MW]
$Q_{max}, Q_{min}$	Turbine outflow limits [m <sup>3</sup> /s]
$R_{up}, R_{dn}$	Total upward/downward reserve [MW]
$S_{cons}$	Energy accumulated in one EV of type i after trip [MWh]
$S_{ev0}$	Initial energy stored in EVs [MWh]
$S_{max}$	Max capacity of one EV of type I [MWh]
$T_{dn}, T_{up}$	Minimum down/up time of thermal PP [h]
$V_k$	Water storage reservoir limit [m <sup>3</sup> ]
$V_{dn}, V_{up}$	Ramp down/up rate [MW/h]

### Variables

$\eta_c$	EVs charging efficiency
$\eta_d$	EVs discharging efficiency
$\Omega$	Wind curtailment [MW]
$a_g, a_p$	Pump-storage decision variable
$C_{HE}$	Hydro power plant total cost [\$/h]
$C_{TE}$	Thermal power plant total cost [\$/h]
$Em$	Total carbon emissions [kgCO <sub>2</sub> ]
$e_{minus}$	Load shedding [MW]
$e_{plus}$	Generation shedding [MW]
$f_{dn} ; f_{up}$	Frequency response of thermal PP [MW]
$f_{dnh} ; f_{uph}$	Frequency response of hydro PP [MW]
$P$	Thermal power plants generation [MW]
$n ; n_h$	Number of thermal/hydro units currently operating
$P_{gridc}$	EVs demand, charging power [MW]
$P_{gridd}$	EVs generation, discharging power [MW]
$P_h$	Hydro power plants generation [MW]
$P_p$	Pump-storage pumping [MW]
$S_{arr}$	Energy stored in EVs arriving to the grid [MWh]
$S_{ev}$	Energy stored in EVs connected to the grid [MWh]
$S_{leav}$	Energy stored in EVs leaving the grid [MWh]

$Q$	Turbine outflow of hydro power plants [ $\text{m}^3/\text{s}$ ]
$Q_p$	Pump flow of pump storage [ $\text{m}^3/\text{s}$ ]
$r_{dn}; r_{up}$	Reserve of thermal PP units [MW]
$r_{hdn}; r_{hup}$	Reserve of hydro PP units [MW]
$S$	Water reservoir spillage [ $\text{m}^3/\text{s}$ ]
$V$	Volume of water reservoir [ $\text{m}^3$ ]
$v_{on}$	Number of start-up gen. units at time $t$
$v_{off}$	Number of shut down gen. units at time $t$
$w$	Wind power plants generation [MW]
$x_c$	Binary variable, if 1 then EVs are charging

## I. INTRODUCTION

Electric power systems are undergoing dramatic changes and challenges. Renewable energy sources penetration is on the increase and the integration of large shares of electric vehicles (EVs) are one of the biggest challenges. Even though RESs and EVs can help reduce CO<sub>2</sub> emissions and increase autonomy of power systems they can also bring disadvantages due to their intermittent characteristics. They can reduce the robustness of the power system and can increase the need for the reserve levels [1].

It is not uncommon to have a renewable energy surplus in certain generation mixes and adaptation of specific management strategies are required in order to avoid renewable generation curtailment [2]. This trend will gain on significance and different integration concepts in various generation mixes will need to be considered [3]. Different systems have different requirement for flexibility. And interdependence of reserve requirement and wind power generation is very important [4].

The goal of a unit commitment problem is to determine the outputs of all the generators with the aim to reduce the overall operational cost. All the constraints and unit parameters must be taken into account [5]. The inclusion of high wind generation and EV shares changes the unit commitment priorities of traditional power plants (hydro and thermal) [6].

The capability to control the charging of the EVs when they are plugged will lower system costs and provide additional support to power system and enable better integration of renewable energy sources. [7] estimates the cost of plug-in electric vehicle and benefits of their implementation in power system. To the opposite, this paper focuses more on reducing curtailed wind for different shares of EVs in total load and investigates global impact of large EVs integration on flexible and non-flexible generation mixes. EVs can be used to provide temporal/energy arbitrage as a flexible load or as additional load capable of reducing the overall system price instead of increasing it. Strategies for coordinated control of all plugged EVs are an important development direction [8], [9].

## II. MODEL FORMULATION

Mixed-integer linear programming model was developed in commercially available solver FICO Xpress [10]. The input data is read from the external excel data sheets where the results are stored and processed. The model is used to solve unit commitment problem in different scenarios. The modelled system consists of  $N_t$  thermo and nuclear power plants,  $N_{th}$  hydro and pumped hydro and wind with addition of electric

vehicles. The total power of this global power system is 50 GW. The scenario analysis was conducted with various shares of generation technologies to simulate different systems with different inherent flexibility for the acceptance of large wind production and EV fleets. The parameters of generation units can be found in the appendix.

### A. Objective function

Objective function (1) is the sum of fixed and variable costs of hydro (HE) and thermal (TE) power plants. To ensure the optimality of reached solutions two additional variables are introduced:  $e_{minus}$  and  $e_{plus}$  representing the surplus or deficiency of energy in the system.  $C_{shed}$  represents VOLL (Value Of Lost Load), the biggest price consumers are willing to pay to ensure no outages at their side occur. Penalty for the injection of energy that is not needed (surplus) is represented with  $C_{over}$ .

$$f_{obj}^{min} = \sum_{t=1}^{N_t} \left\{ \sum_{i=1}^{N_i} [C_{TE}(t,i)] + \sum_{i=1}^{N_{ih}} [C_{HE}(t,i)] + e_{minus}(t) \cdot C_{shed} + e_{plus}(t) \cdot C_{over} \right\} \quad (1)$$

TEP cost ( $C_{TE}$ ) consists of 3 parts, start-up costs ( $C_{start}/C_{shut}$ ), operational costs and emissions costs ( $Em_c$ ). Operational costs are dependent on the fuel consumption curve and are approximated by the linear characteristic showing the dependency of operational costs on output power. In equation (2) fixed costs ( $A$ ) are not dependent on output power of plant  $i$  in time step  $t$  ( $P(t,i)$ ) whereas variable costs ( $B$ ) are.

$$C_{TE}(t,i) = v_{on}(t,i) \cdot C_{start}(i) + v_{off}(t,i) \cdot C_{shut}(i) + A(i) \cdot n(t,i) + B(i) \cdot P(t,i) + Em(t,i) \cdot Em_c(i), \quad t \in [1, N_t], i \in [1, N_i] \quad (2)$$

Vector  $n$  shows how many TPPs are in operation at any given moment while  $v_{on}$  and  $v_{off}$  show how many of them have been turned on or off.

$$\begin{aligned} v_{on}(t,i) &\geq n(t,i) - n(t-1,i), t \in [1, N_t], i \in [1, N_i] \\ v_{off}(t,i) &\geq n(t-1,i) - n(t,i), t \in [1, N_t], i \in [1, N_i] \end{aligned} \quad (3)$$

Emissions consist of start-up emissions ( $Em_{rstart}$ ) and follow up emission in operation ( $Em_r$ ).

$$Em(t,i) \geq v_{on}(t,i) \cdot Em_{rstart}(i) + P(t,i) \cdot Em_r(i) \quad (4)$$

HPP costs are also divided on fixed ( $A_h$ ) and variable cost ( $B_h$ ). They are being considered because in case of surplus of renewable energy the water energy is shed. Vector  $n_h$  shows how many HPPs are in operation at any given moment while  $P_h$  is HPPs output power and  $P_p$  is pumping output of pump storage (PS).

$$C_{HE}(t,i) = A_h(i) \cdot n_h(t,i) + B_h(i) \cdot (P_h(t,i) + P_p(t,i)), \quad t \in [1, N_t], i \in [1, N_{ih}] \quad (5)$$

### B. System constraints

The basic equilibrium between the generation and production must be satisfied at all time steps. In equation (6) contributors on the left side are: TPP generation, HPP generation, wind generation, EVs charge and discharge, surplus



and deficiency of energy, and on the right total system demand ( $D$ ).

$$\begin{aligned} & \sum_{i=1}^{G_i} P(t,i) + \sum_{i=1}^{G_h} [P_h(t,i) - P_p(t,i)] + w(t) - \dots \\ & \dots - \sum_{i=1}^{N_i} P_{gridc}(t,i) + \sum_{i=1}^{N_i} P_{gridd}(t,i) + e_{minus}(t) - e_{plus}(t) = D(t) \end{aligned} \quad (6)$$

The power system must have certain amount of flexibility to compensate unplanned changes in production or in consumption, also distinction is made between slow and fast changes. Therefore upward and downward reserves (secondary f-P control) are introduced for slower and longer changes (e.g. generator outages). It is assumed that reserve is modelled with the synchronized generators. Sum of spinning reserve from hydro ( $r_{hup}$ ,  $r_{hdn}$ ) and thermo generator units ( $r_{up}$ ,  $r_{dn}$ ) must meet the system requirements ( $R_{up}$ ,  $R_{dn}$ ) at any given time step:

$$\begin{aligned} & \sum_{i=1}^{N_i} r_{up}(t,i) + \sum_{i=1}^{N_{ih}} r_{hup}(t,i) \geq R_{up}(t), \quad t \in [1, N_t] \\ & \sum_{i=1}^{N_i} r_{dn}(t,i) + \sum_{i=1}^{N_{ih}} r_{hdn}(t,i) \geq R_{dn}(t), \quad t \in [1, N_t] \end{aligned} \quad (7)$$

The required reserve increases through time. It is the smallest in the first hour of time horizon and increases towards the end (24th hour). This is caused by the increase of standard deviation of forecast error of output power of RES generation and consumption in commonly used 24 hour planning horizon.

Primary f-P control is done by thermo ( $f_{up}$ ,  $f_{dn}$ ) and hydro ( $f_{hup}$ ,  $f_{hdn}$ ) turbine regulators that compensate fast and sudden changes in frequency ( $F_{up}$ ,  $F_{dn}$ ):

$$\begin{aligned} & \sum_{i=1}^{N_i} f_{up}(t,i) + \sum_{i=1}^{N_{ih}} f_{hup}(t,i) \geq F_{up}(t), \quad t \in [1, N_t] \\ & \sum_{i=1}^{N_i} f_{dn}(t,i) + \sum_{i=1}^{N_{ih}} f_{hdn}(t,i) \geq F_{dn}(t), \quad t \in [1, N_t] \end{aligned} \quad (8)$$

Detailed model of spinning reserve and frequency response characteristics of TPP can be found in literature [11].

### C. Thermal and hydro power plants

In the following section characteristics of traditional power plants are described. The thermal power plants are described in short. Due to the limited space and a large number of modelled constraints only the hydro power plants will be described while the same methodology with certain modifications can be applied on the pumped-hydro power plants.

The flexibility of different generator units depends on its technical minimum (9), minimum up ( $T_{up}$ ) and down ( $T_{dn}$ ) times (10) and ramp characteristics  $V_{up}$  and  $V_{dn}$  (11):

$$n(t,i) \cdot P_{max}(i) \geq P(t,i) \geq n(t,i) \cdot P_{min}(i) \quad (9)$$

$$\begin{aligned} & \sum_{\tau=1}^{t-1} v_{on}(\tau,i) \leq n(t,i), \quad t \leq T_{up} \\ & \sum_{\tau=t-T_{up}}^{t-1} v_{on}(\tau,i) \leq n(t,i), \quad t > T_{up} \\ & G(i) - \sum_{\tau=1}^{t-1} v_{off}(\tau,i) \geq n(t,i), \quad t \leq T_{dn} \\ & G(i) - \sum_{\tau=t-T_{up}}^{t-1} v_{off}(\tau,i) \geq n(t,i), \quad t > T_{dn} \\ & t \in [1, N_t - 1], i \in [1, N_i] \end{aligned} \quad (10)$$

$T_{up}$  and  $T_{dn}$  are expressed in number of time intervals.

$$\begin{aligned} & P(t,i) - P(t-1,i) \leq n(t-1,i) \cdot V_{up}(i) \cdot \Delta + v_{on}(t,i) \cdot P_{min}(i) \\ & P(t,i) - P(t-1,i) \leq (P_{max}(i) \cdot n(t-1,i) - P(t-1,i)) + v_{on}(t,i) \cdot P_{min}(i) \\ & P(t-1,i) - P(t,i) \leq n(t,i) \cdot V_{dn}(i) \cdot \Delta + v_{off}(t,i) \cdot P_{min}(i) \\ & t \in [1, N_t], i \in [1, N_i] \end{aligned} \quad (11)$$

HPP have the ability to store certain amounts of water, i.e. they operate as energy storage units which increases total system flexibility. Water equilibrium equation (12):

$$V(t,i) = V(t-1,i) \cdot kv(i) + I(t,i) \cdot 3600 \cdot \Delta - Q(t,i) \cdot 3600 \cdot \Delta - S(t,i) \cdot 3600 \cdot \Delta \quad t \in [1, N_t], i \in [1, N_{ih}] \quad (12)$$

$V(t,i)$  is the water reservoir volume,  $I(t,i)$  is the inflow,  $Q(t,i)$  is the turbine flow,  $S(t,i)$  is the spillage while  $kv(i)$  represent the water accumulation losses. HPP output is dependent on turbine flow and due to linearization of the model head  $H(i)$  and water density ( $\rho_h$ ) are constant:

$$P_h(i) = \eta_h(i) \cdot H(i) \cdot Q(t,i) \cdot g \cdot \rho_h, \quad t \in [1, N_t], i \in [1, N_{ih}] \quad (13)$$

Volume must at all times be smaller than the maximum (14); spillage is limited with the maximum value to avoid too fast accumulation drain (15); turbine flow have its maximum and minimum values (16) and number of online units must be less or equal then total number of units (17). More details about HPP modelling is given in [12].

$$V_k(i) * G_h(i) \geq V(t,i) \geq 0 \quad (14)$$

$$2 * G_h(i) * Q_{max}(i) \geq S(t,i) \geq 0 \quad (15)$$

$$Q_{max}(i) * n_h(t,i) \geq Q(t,i) \geq Q_{min}(i) * n_h(t,i) \quad (16)$$

$$n_h(t,i) \leq G_h(i), \quad t \in [1, N_t], i \in [1, N_{ih}] \quad (17)$$

### D. Electric Vehicles

Electric vehicles represent additional demand for power systems but with smart charging schemes the impact can not only be compensated but EVs can provide additional flexibility. The basic EV behaviour is modelled with equations (18)-(21).

Energy stored in plugged EVs is represented with the following equation where contributors are: total energy accumulated in EVs plugged into the grid ( $S_{ev}$ ), total energy accumulated in EVs plugged into the grid at past time step  $S_{ev}(t-1, i)$ , efficiency of charge/discharge ( $\eta_c$   $i$   $\eta_d$ ), charge/discharge power ( $P_{gridc}$   $i$   $P_{gridd}$ ), energy of arriving EVs ( $S_{arr}$ ) and leaving EVs ( $S_{leav}$ ).  $\Delta$  is time step of 0.5 h.

$$S_{ev}(t, i) = S(t-1, i) + \eta_c(i) \cdot P_{gridc}(t, i) \cdot \Delta - \eta_d \cdot P_{gridd}(t, i) \cdot \Delta \quad (18)$$

$$\dots + S_{arr}(t, i) - S_{leav}(t, i), i \in [1, N_t], i \in [1, N_{ev}]$$

The initial and final energy of EVs must match according to following equation:

$$S_{ev}(N_t, i) \geq S_{ev0}(i); \quad i \in [1, N_{ev}], i \in [1, N_t] \quad (19)$$

Constraints regarding the energy of arriving (20) and leaving (21):

$$S_{arr}(t, i) = n_{arr}(t, i) \cdot S_{cons}(i) \quad (20)$$

$$S_{leav}(t, i) = n_{leav}(t, i) \cdot S_{max}(i) \quad (21)$$

Every EV which arrives to the grid has lower energy accumulated in its battery compared with the energy accumulated when it left the grid, how low depending on EVs characteristics and trip length. Vector  $n_{arr}$  shows how many EVs of type  $I$  are arriving to the grid at time  $t$ , and parameter  $S_{cons}$  presents energy accumulated in one EV of type  $i$  after his trip. There are six types of EVs considered in this paper, they are described later in paper. EVs leaving the grid (21) need to be fully charged when leaving the grid, i.e. total energy accumulated in EVs leaving the grid is equal to number EVs leaving the grid ( $n_{leav}$ ) multiplied with their maximum capacity ( $S_{max}$ ).

Additionally, the model is expended to investigate the behaviour of EV fleets under different charging schemes (user must choose charging scheme before simulation):

- Passive charging:

Passive charging assumes that every EV that arrives and plugs into the grid will be charged at full power until charged fully. Equation (22) ensures that the total demand of all EV is higher or equal to the amount of arrived vehicles and ones that were initially plugged in. This condition is valid until time step  $N_c$  when EV that were initially connected get fully charged.

$$P_{gridc}(t, i) \geq n_{arr}(t, i) \cdot P_{evmax}(i) + P_{gridc}(t-1, i) \quad (22)$$

$$t \in [1, N_c], i \in [1, N_{ev}]$$

$$N_c = (S_{max} - S_{cons}) / \Delta \cdot P_{evmax} \quad (23)$$

From time step  $N_c$  to  $N_t$  (total simulation time) equation (24) ensures that the total demand of EVs is higher or equal to the sum of arrived EV in certain time step and vehicles plugged in from time step  $t - N_c$  to  $t$ .

$$P_{gridc}(t, i) \geq n_{arr}(t, i) \cdot P_{evmax}(i) + \sum_{\tau=t-N_c-1}^{t-1} n_{arr}(\tau, i) \cdot P_{evmax}(i) \quad (24)$$

$$t \in [N_c, N_t], i \in [1, N_{ev}]$$

$P_{gridd}$  (25) shows that in this charging mode EV are not able to inject power into the grid.

$$P_{gridd}(t, i) = 0; \quad t \in [1, N_t], i \in [1, N_{ev}] \quad (25)$$

- Optimal active charging G2V (*Grid-to-Vehicle*):

G2V charging mode allows the optimal allocation of charging resources. This means the vehicles do not need to be charged at maximum power at minimum time period.

The following equations ensure that the EVs demand is limited with its minimum and maximum values:

$$P_{gridc}(t, i) \geq n_g(t, i) \cdot P_{evmin}(i); \quad t \in [1, N_t], i \in [1, N_{ev}] \quad (26)$$

$$P_{gridc}(t, i) \leq n_g(t, i) \cdot P_{evmax}(i); \quad t \in [1, N_t], i \in [1, N_{ev}] \quad (27)$$

G2V charging scheme does not support injection of energy stored in EV back into the grid.

$$P_{gridd}(t, i) = 0; \quad t \in [1, N_t], i \in [1, N_{ev}] \quad (28)$$

- Optimal active charging V2G (*Vehicle-to-Grid*) with the possibility to inject power to the grid:

V2G mode of charge allows to optimization model to use the full potential of EVs and to inject their power into the grid if needed.

The following simple equations model the behaviour of EVs in V2G mode. Binary variable  $x_c$  is 1 if power is being taken from the grid (EV charging) and 0 if the power is being injected. Therefore, at the same time step EVs cannot simultaneously be charged and discharged. Equations (29) and (30) model the charging of EV in V2G mode:

$$P_{gridc}(t, i) \geq n_g(t, i) \cdot P_{evmin}(i) \cdot x_c(t, i); \quad t \in [1, N_t], i \in [1, N_{ev}] \quad (29)$$

$$P_{gridc}(t, i) \leq n_g(t, i) \cdot P_{evmax}(i) \cdot x_c(t, i); \quad t \in [1, N_t], i \in [1, N_{ev}] \quad (30)$$

Discharge constraints are modelled with:

$$P_{gridd}(t, i) \geq n_g(t, i) \cdot P_{evmin}(i) \cdot (1 - x_c(t, i)), i \in [1, N_{ev}] \quad (31)$$

$$P_{gridd}(t, i) \leq n_g(t, i) \cdot P_{evmax}(i) \cdot (1 - x_c(t, i)), i \in [1, N_{ev}] \quad (32)$$

EVs are classified in two groups of transportation patterns: personal vehicles and public transportation. Personal vehicles resemble typical diurnal driving behaviour patterns such as leaving in morning (to go to work) and arriving home at afternoon. This means that EVs are mostly available for charging at night (approximation of 90%) or around noon (approximation of 40%). Their behaviour changes at weekends when they are used later in mornings and more uniformly throughout day. They can cover the distance of around 60 km with single charging. Second group is public transportation which implies bigger batteries and longer trips (100 km). Their driving pattern is uniformly distributed throughout day and they are available for charging only at nights. Also, both groups are divided into three trip lengths: short, medium, long (completely depletion of battery). More detailed data about EVs is given in table I.

TABLE I. ELECTRIC VEHICLES PARAMETERS

Input parameter		Personal vehicle	Public transport
$P_{min}$ [kW]		0,2	2
$P_{max}$ [kW]		4	40
$S_{min}$ [kWh]		3	24
$S_{max}$ [kWh]		15	120
Consumption [kWh/km]		0,2	0,8
$S_{minc}$ [kWh]		15	120
$\eta_c$		0,9	0,9
$\eta_d$		0,9	0,9
Range [km]	short	20 km	60 km
	medium	40 km	80 km
	long	60 km	100 km
Percent of EVs type and range in total number of EVs	short	15%	2,5%
	medium	60%	2,5%
	long	15%	5%

### III. SCENARIOS SELECTION AND RESULTS

Scenarios representing different generation mixes were selected. Table II. shows three cases, i.e. three different generation mixes:

- Dominantly nuclear-coal thermo system (non-flexible thermo - nonFTh);
- Dominantly coal-gas thermo system (flexible thermo - FTh);
- Dominantly hydro-thermo system (decently flexible system - HyTh).

TABLE II. SCENARIOS GENERATION MIXES

Gen. type *	NPP [%]	Coal [%]	Oil [%]	CGT			HPP	
				Open [%]	Comb [%]	Acc [%]	Run. [%]	Pump [%]
nonFTh	45	40	5	10	0	0	0	0
FTh	15	20	10	40	15	0	0	0
HyTh	20	20	0	10	0	15	20	15

\*percent of totally needed generation capacity to cover demand, reserve and primary control requirements

For each scenario 4 cases were considered, one without EV, and the other three with 20% EVs penetration for passive charging, G2V and V2G charging modes. Theoretically maximum EV demand is therefore 10 GW. Practically that demand level of EV is never reached since all of the EVs are not connected on the grid at the same time. The simulation is run over a period of one week.

Only the case for non-flexible thermo system is described since the similar process occurs in other two scenarios (flexible thermo and hydro-thermo) regarding the differences between the charging modes. Displayed graphs (Figure 1-3) point on EVs impacts on generation scheduling. EVs in passive charging mode evidently increase peak load (Figure 2) compared to the base case without EVs (Figure 1). Increased peak load results in less stable power system operation and require additional generating units to be scheduled. Contrary to passive charging mode G2V and V2G modes do not increase peak load because EVs are optimally charged mostly at night and therefore there is no need for new generation units start-

ups or scheduling of extra generation capacity. Additionally, V2G mode slightly decreases required generation at peak hours.

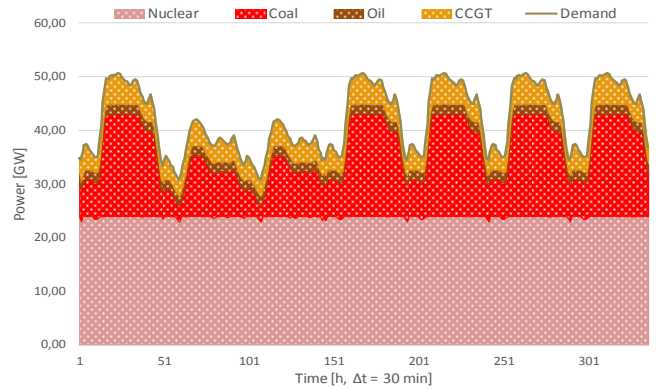

Fig. 1. Non flexible thermo system base case without EVs

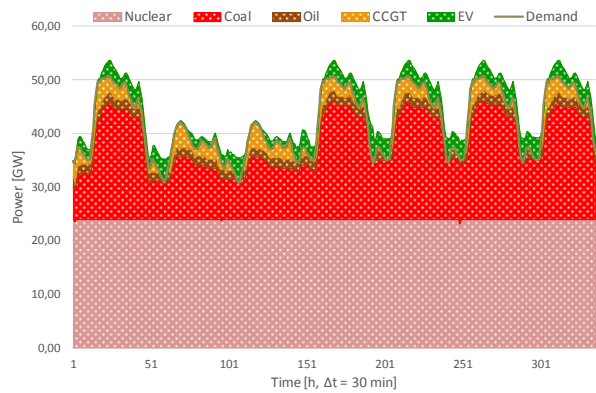

Fig. 2. Non flexible thermo system passive charging

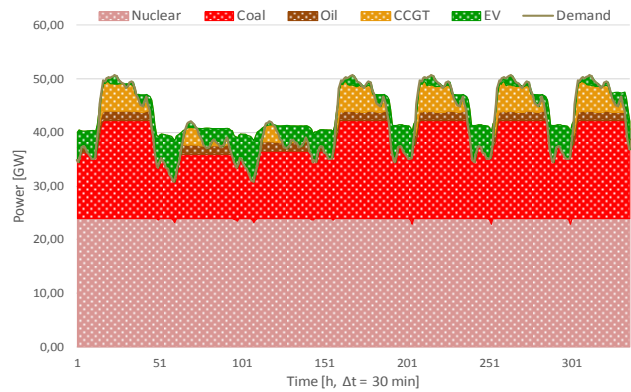

Fig. 3. Non flexible thermo system V2G charging mode

Figure 4 depicts total system cost for different scenario and charging modes. Evidently, EVs in passive charging mode increase system cost (Figure 4) in addition to the increase of peak load (Figure 1-2). When observing displayed cases, biggest increase in system costs (in percent) has hydro-thermo scenario because additional expensive thermo units needs to be started up in order to cover the newly connected load of EVs. But when comparing passive charging and G2V or V2G

charging modes hydro-thermo case has the lowest cost decrease because of its high flexibility.

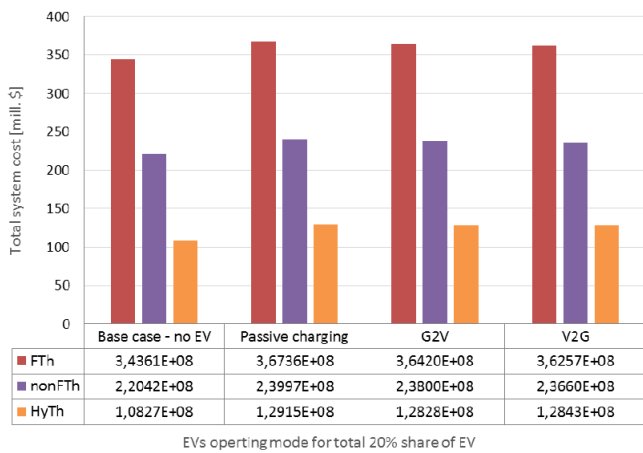

Fig. 4. Total system costs for chosen scenarios depending on charging mode

Second series of results again refer to non-flexible thermo case with different shares of wind penetration and EVs. Here are displayed 3D graphs presenting total system costs (Figure 4), total CO2 emissions (Figure 6) and curtailed wind (Figure 7) for wind and EVs penetration in range from 0% to 60% of maximum consumption. The percentages are vast for the present state but in a longer planning horizon are not unexpected and it is worthy to study these trends.

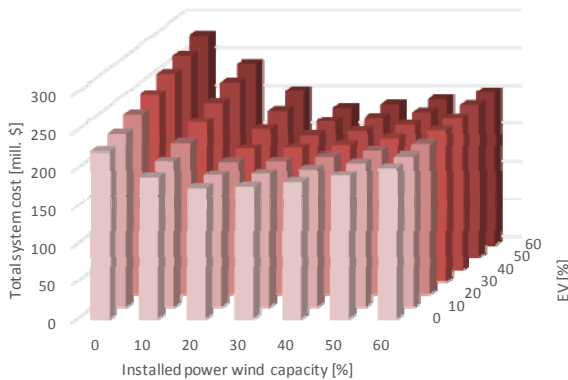

Fig. 5. Total system costs interdependence on wind and EV penetration in non flexible thermal scenario and G2V charging mode

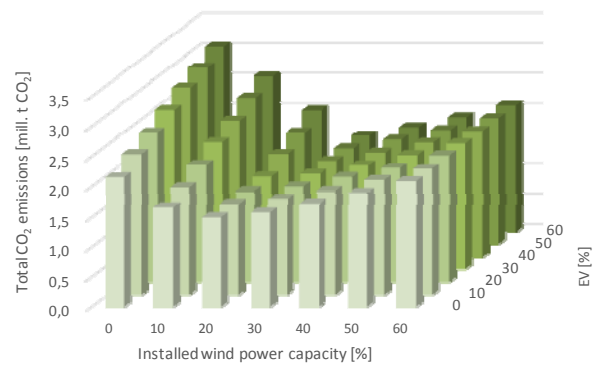

Fig. 6. Total CO2 emission interdependence on wind and EV penetration in non flexible thermal scenario and G2V charging mode

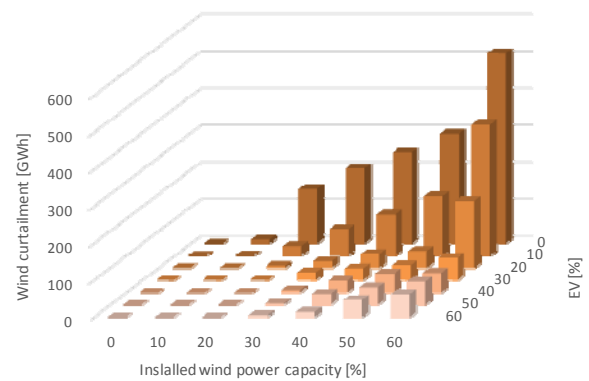

Fig. 7. Wind curtailment interdependence on wind and EV penetration in non flexible thermal scenario and G2V charging mode

Interesting to note is result for 0% EVs penetration on all three graphs. Total system cost decrease until wind penetration reaches 30% and then it starts to increase. Reason for this lies in fact that up to 30% of wind penetration, system operator was shutting down expensive coal fired plants, and nuclear power plants were scheduled rather constantly. When wind penetration reached 30%, system operator was not able to shut down the same amount of coal fired plants because they are needed for to ensure sufficient reserve. Therefore nuclear power generation was decreased. With further increase of wind penetration reserve requirements also increase which means that total coal generation was increased and total nuclear power generation was decreased even further. This leads to increase of total system cost. When EVs penetration is increased for no wind generation case (0% wind penetration) total system costs and emissions increase as well. This happens because, from systems point of view, EVs represent new load connected to system. That increase in costs is significantly lower when there is a large share of wind generation connected to the system. This means that EVs have positive impact on power systems with large shares of wind generation. Same applies vice versa for systems with large EV shares and addition of wind generation. The similar trend applies to total CO2 emissions.

Curtailed wind generation does not have such turnover at 30% of wind penetration, but rather a linear increase in curtailed wind in the range of 0% to 60% of wind penetration.

Curtailed wind generation is significantly decreased up to 30% EVs, further increase in EVs have negligible impact on curtailed wind generation.

#### IV. CONCLUSION AND FUTURE WORK

The presented work provides a detailed mathematical formulation of Unit Commitment model based on MILP and presents several interesting results over a set of scenarios varying energy mix, EVs and RESs penetration level as well as charging concept of EV.

For a Non-flexible systems total cost is increased by 7% when 10 GW EV passive load is introduced without the possibility to optimally charge it. On the other hand in highly flexible system total cost is increased 19.29% which is almost three times more than in non-flexible thermal system. On the other hand, in scenarios where coordinated charging is introduced, in V2G concept, decrease in total system cost for non-flexible thermal system is 1.3%. For the same event hydro-thermo (Hy-Th) case sees a decrease that is much smaller, only 0.55%. It should be noted that the difference are a bit more substantial if comparing coordinated and non-coordinated charging where both systems gain significant benefits from intelligent EVs charging. With the integration of EVs the wind curtailment in case of 30% wind penetration is reduced drastically. In case of 0% of EVs wind curtailment is 203.6 GWh. With the introduction of 10% EVs in G2V mode the wind curtailment drops 64% to the amount of 73.15 GWh. The additional increase in EV share (to total of 20%) reduces the curtailed energy to only 19 GWh (that is 10.2% of initial value).

Future research will be focused on changes in reserve requirements due to integration of EVs and their capability to participate in mitigating reserve requirements from classical fossil based power plants. The more thorough emissions and environmental analysis will be made.

#### ACKNOWLEDGMENT

The work of the authors is a part of the Flex-ChEV - Flexible Electric Vehicle Charging Infrastructure funded by Smart Grids ERA-Net under project grant No. 13 and FENISG - Flexible Energy Nodes in Low Carbon Smart Grid funded by Croatian Science Foundation under project grant No. 7766.

#### REFERENCES

[1] J. A. Pecas Lopes, P. M. Rocha Almeida and F. J. Soares, "Using Vehicle-to-Grid to Maximize the Integration of Intermittent Renewable Energy Resources in Islanded Electric Grids" Clean Electrical Power, 2009 International Conference on, pp. 290-295, 2009

[2] A. Estanqueiro, J. Ferreira de Jesus, J. Ricardo, Amarante dos Santos, J. A. Pecas Lopes, "Barriers (and Solutions...) to Very High Wind Penetration in Power Systems", Power Engineering Society General Meeting 2007, pp. 1-7, 24-28 June 2007.

[3] R. Loisel, G. Pasaoglu and C. Thiel, "Large-scale deployment of electric vehicles in Germany by 2030: An analysis of grid-to-vehicle and vehicle-to-grid concepts, Energy Policy 65, pp. 432-443, 2014

[4] M. A. Ortega-Vasquez and D. S. Kirschen, "Estimating the Spinning Reserve Requirements in Systems With Significant Wind Power Generation Penetration", IEEE Transactions on Power System, Vol 24., No 1., February 2009.

[5] H. Pandžić, T. Qiu and D. S. Kirschen, "Comparison of State-of-the-Art Transmission Constrained Unit Commitment Formulations" IEEE Power and Energy Society General Meeting (PES) 2013, pp. 1-5., 2013.

[6] D. Madzharov, E. Delarue and W. D'haeseleer, "Integrating electric vehicles as flexible load in unit commitment modeling", Energy 65, pp. 285-294, 2014.

[7] J. Kivilouma and P. Meibom, "Methodology for modelling plug-in electric vehicles in power system and cost estimates for a system with either smart and dumb electric vehicles", Energy 36, pp 1758-1767, 2011.

[8] M. A. Ortega-Vasquez, F. Bouffard and V. Silva, "Electric Vehicle Aggregator/System Operator Coordination for Charging Scheduling and Service Procurement, IEEE Transactions on Power Systems, vol. 28, No.2, May 2013.

[9] E. Sortomme and M. A. El-Sharkawi, "Optimal Charging Strategies for Unidirectional Vehicle-to-Grid", IEEE Transactions on Smart Grid, Vol 2, No. 1, March 2011.

[10] FICO Xpress [Online]. Available and accessed July, 2014: <http://www.fico.com/en/products/fico-xpress-optimization-suite/>

[11] Bryan S. Palmintier: "Incorporating Operational Flexibility into Electric generation Planning", Doctoral thesis, Massachusetts Institute of Technology, Massachusetts, 2013.

[12] C. G. Baslis, A. G. Bakirtzis, "Optimal Yearly Scheduling of Generation and Pumping for a Price-Maker Hydro Producer" IEEE 7th International Conference on the European Energy Market (EEM), 2, pp. 1-6., 2010.

APPENDIX

TABLE III. THERMO POWER PLANTS PARAMETERS

<i>Input parameter</i>	<i>Nuclear</i>	<i>Coal</i>	<i>CCGT</i>	<i>OCGT</i>	<i>OIL</i>
$P_{\min}$ [MW]	380	300	26	8	100
$P_{\max}$ [MW]	400	350	50	20	200
A [\$]	190	250	626	450	500
B [\$/MWh]	7,2	24	29	30	26
$C_{\text{start}}$ [\$]	35000	20000	60	46	5000
$C_{\text{shut}}$ [\$]	3500	2000	23	10	500
$T_{\text{up}}$ [h]	36	20	6	4	10
$T_{\text{dn}}$ [h]	24	14	4	2	8
$V_{\text{up}}$ [MW/h]	40	60	120	90	100
$V_{\text{dn}}$ [MW/h]	40	60	120	100	100
$F_{\text{iup}}$ [MW]	52	42	6	2	20
$\rho$	0,6	0,6	0,7	0,8	0,6
$Em_r$ [kgCO <sub>2</sub> /MWh]	0	800	393	600	700
$Em_{\text{rstart}}$ [kgCO <sub>2</sub> ]	0	30000	8000	3000	2000

TABLE IV. HYDRO POWER PLANTS PARAMETERS

<i>Input parameter</i>	<i>Run-of-river HPP</i>	<i>Conventional HPP</i>	<i>Pumped storage</i>
$P_{\text{hmin}}$ [MW]	10	100	65
$P_{\text{hmax}}$ [MW]	50	250	275
$A_h$ [\$]	20	200	300
$B_h$ [\$/MWh]	1	1,5	2
H [m]	100	238	519
$Q_{\text{min}}$ [m <sup>3</sup> /s]	15	50	15
$Q_{\text{max}}$ [m <sup>3</sup> /s]	60	120	60
$V_k$ [m <sup>3</sup> ]	0	$2,60 \cdot 10^7$	$1,27 \cdot 10^7$
$\eta_h$	0,9	0,9	0,9
$P_{\text{pmin}}$ [MW]	0	0	35
$P_{\text{pmax}}$ [MW]	0	0	140
$Q_{\text{pmin}}$ [m <sup>3</sup> /s]	0	0	10
$Q_{\text{pmax}}$ [m <sup>3</sup> /s]	0	0	40
$V_{\text{lk}}$ [m <sup>3</sup> ]	0	0	$1,68 \cdot 10^5$
$\eta_{\text{hp}}$	0	0	0,8



### **Publication 7**

I. Pavić, T. Capuder, and I. Kuzle, “Defining the Role of Traditional and Low Carbon Technologies in Providing Flexibility for Future Power Systems Operation,” in *Digital Proceedings of the 10th Conference on Sustainable Development of Energy, Water and Environment Systems – SDEWES*, 2015



# Defining the Role of Traditional and Low Carbon Technologies in Providing Flexibility for Future Power Systems Operation

Ivan Pavić<sup>1</sup>, Tomislav Capuder<sup>1\*</sup>, Igor Kuzle<sup>1</sup>

<sup>1</sup>University of Zagreb Faculty of Electrical Engineering and Computing  
Unska 3, Zagreb, Croatia  
\*tomislav.capuder@fer.hr

## ABSTRACT

The paper presents a unit commitment model, based on mixed integer linear programming, capable of assessing the impact of electric vehicles (EV) on provision of ancillary services in power systems with high share of renewable energy sources (RES). The analyses show how role of different conventional units changes with integration of variable and uncertain RES and how introducing a flexible sources on the demand side, in case EV, impact the traditional provision of spinning/contingency reserve services. In addition, technical constraints of conventional units, such as nuclear, gas or coal, limit the inherit flexibility of the system which results in curtailing clean renewable sources and inefficient operation. Following on that, sensitivity analyses of operational cost and wind curtailment show which techno-economic constraints impact the flexibility of the high RES systems the most and how would integration of more flexible units or decommissioning of conventional nuclear, coal and gas driven power plants impact the system's operation.

## KEYWORDS

Ancillary services, electric vehicles, flexibility, power plant decommissioning, power system operation, reserve services

## INTRODUCTION

Emerging integration of so called low carbon technologies (LCT), which are considered to be the essential link in creation of sustainable energy future, redefines operation and planning concepts of traditional energy systems. As the environmental goals of reducing CO<sub>2</sub> emissions drive the energy regulatory frameworks towards “all electric” system by stimulating electrification of heat and transport as the most significant greenhouse gas emission sectors, the power system operators and regulators face a challenge of planning and operating such systems [1]. While electric vehicles (EV) and, potentially, electrified heating (EH) act as sources of the variability and uncertainty from the demand side [2] integration of renewable energy sources additionally contributes to this from the supply side [3]. To alleviate the uncertain and variable nature of renewable energy sources (RES) new sources of flexibility become of critical value. While a number of studies address the integration of electric vehicles (EV) [4], different energy storage technologies (ES) [5], [6], [7] and demand response programs (DR) [8], [9], rarely they address the impact on power system operation planning and scheduling and how their integration impacts the existing generation units role in the system.

A number of models have been proposed for simulation of power system operation, in order to assess the power system operational flexibility. These mathematical models, so called unit

commitment schedules (UC), are most commonly based on Lagrangian relaxation [10] or more currently on mixed integer linear programming (MILP) [11], also modelling variability and uncertainty of both demand and supply by including stochasticity of wind, demand and market prices [12], [13], [14]. The model presented in this paper is based on a technique of clustering similar units, for example gas, coal and nuclear; this approach has been shown to significantly increase the computational speed of simulations [15], [16], without losing on the accuracy of the results. Similar approach, simulating impact of EV integration on multiple interconnected systems can be found in [17], [18]. The presented model is a continuation of work presented in [19] where the authors focus on how integration of controllable electric vehicle charging impacts the provision of secondary reserve services for various power systems with regards to the energy mix. In this paper, however, the focus is on answering several other questions, as follows:

- LCT technologies (EV, ES and DR) contribute to flexibility of future power systems characterized by high share of renewable sources. The results of the model clearly show how roles of traditional generation units in providing multiple services (energy and multiple reserve services) change with the integration of these technologies, specifically focusing on the role of EV.
- It addresses the issues of how traditional scheduling principles can limit the flexibility of these systems. The methodology for dispatching the traditional thermal power plants, both fossil fuel based and nuclear, can have a reverse impact of the desired, not using the inherent flexibility of the system and curtailing clean renewable sources.
- With respect to the above, the model demonstrates how decommission of traditional units impacts the flexibility of the system and, in particular, focuses on redistribution between sources for provision of energy and reserve services.

The above issues are, up to a certain point, a research topic in a number of papers, see for example [20], however with several very important differences. In [21] and [22] the authors define the flexibility through minimum stable generation (MSG) of the power system as metric critical for integration of large scale wind. In [21] a metric is proposed for defining the amount of wind that can be integrated without curtailment, however it focuses only on the value of MSG, neglecting the ramping and other relevant technical constraints such as minimum up and down times of units being scheduled. In addition, neither of the papers elaborates on the mathematical models used to study the flexibility or elaborates on multiple services assigned/scheduled to particular units. A number of papers [23], [24], [25] propose pathways for achieving high RES integration, however they are not based on mathematical modelling nor do they focus on provision of flexibility services from specific technologies. On the other hand, [26] and [27] model provision of multiple services but do not focus on flexibility and integration of RES rather on reliability aspects of power system operation and reduction of CO<sub>2</sub> emissions. In [28], [29] the authors propose a rolling UC for planning of future power systems. The focus of the work is on technical and economic constraints of the system for future wind scenarios. With respect to that they propose a flexibility metric for planning high RES system energy mix, taking into account MSG and ramping constraints of existing and new units. Similar idea can be found in [30] where the author analyses impact of relaxing UC constraints on the accuracy of the results in UC scheduling. Neither of these two papers considers EV nor their contribution to the flexibility services in integration of RES. Finally, in [31] the authors evaluate impact of electric vehicles on future energy portfolio. The impact of coordinated charging of electric vehicles is assessed for multiple countries where EV are controlled in order to increase the flexibility by providing energy arbitrage. None of the multiple reserve services are specifically considered.

The MILP model of UC presented in this paper is unified in terms that it allows the above mentioned analyses for different energy mix power systems, ranging from low flexible nuclear dominated power system, such as the one in UK, to highly flexible hydro dominated power system, similar to the one in Croatia. It models multiple reserve services, primary, secondary and tertiary, as in [32] and [33], and focuses on the impact integration of EV will have on the role of existing units in future high RES scenarios.

The paper is organized as follows: In Section II detailed explanation of the MILP model of multiple service UC is given. Modelling of EV is based on mobility patterns and considers different vehicles sizes and batteries on board of the vehicles. Although EV can be scheduled for provision of multiple services, in Section III an analysis of spinning reserve is given through different scenarios of wind and EV penetration. Section IV further analyses the flexibility of the system in the presence of EV and wind, analysing how different constraints of scheduled units impact the provision of flexibility. Finally, Section V provides conclusions and guidelines for future work.

### Multiple service unit commitment (MSUC) modelling

The presented model is similar to the one presented by the authors in [19], however for easier understanding it will be again elaborated in the following Section.

The objective function driving the power system operation is minimization of the operational costs from all units providing energy and reserve services to the system, as shown in (1). The objective function models all operational costs of thermal (start-up, shut-down, fuel, O&M, greenhouse gas emissions) and hydro (O&M) units, linearizing fuel consumption curve of thermal power plants as in [34], [35].

$$\text{minimize } COST = \sum_{t=1}^{Nt} \left[ \sum_{i=1}^{Ni\_TP} (c_{t,i}^{-TP}) + \sum_{i=1}^{Ni\_HP} (c_{t,i}^{-HP}) \right] \quad (1)$$

Electricity equilibrium has to be maintained in all simulation periods, meaning that the total generation from all units in the system has to be equal to the total demand as shown in equation (2). Left side of the equations summarized the production of all generation units considered; conventional units (since the model is unified these can be thermal –  $p^{g\_TP}$ , hydro –  $p^{g\_HP}$ , generation from hydro pump storage unit –  $p^{g\_PS}$ ), RESs (wind –  $p^{g\_WP}$ ), storage (in this paper pump storage pumping -  $p^{p\_PS}$ ; is considered as storage technology) with added EVs discharging ( $p^{d\_EV}$ ), charging ( $p^{c\_EV}$ ) and fast charging ( $p^{f\_EV}$ ). The right side of the equations models electric demand ( $P^d$ ). For the case of UK power system, taken as an example of low flexible power system driven by thermal power plants, demand and wind profiles are shown in Figure 1 [36]. Additional data about UK power system used can be found in [37].

$$\sum_{i=1}^{Ni\_TP} (p_{t,i}^{g\_TP}) + \sum_{i=1}^{Ni\_HP} (p_{t,i}^{g\_HP}) + \sum_{i=1}^{Ni\_PS} (p_{t,i}^{g\_PS} - p_{t,i}^{p\_PS}) + p_t^{g\_WP} - \sum_{i=1}^{Ni\_EV} (p_{t,i}^{d\_EV} - p_{t,i}^{c\_EV} - p_{t,i}^{f\_EV}) = P_t^d \quad (2)$$

The reserve requirements of the system are modelled by (3) – (7). Multiple reserve services are modelled; primary up reserve ( $f_{up}$ ), primary down reserve ( $f_{dn}$ ), secondary up reserve ( $r_{up}$ ), secondary reserve down ( $r_{dn}$ ), tertiary up reserve ( $q_{up}$ ). The primary reserve can be provided by all units, as shown in (3) and (4), however technical limitations of the power plants usually mean that power plants usually participate with about 10% in the primary frequency provision. Modelling primary frequency response is based on the model in [38]. Primary reserve value that

needs to be reserved for the simulated system, both up and down, is set to 1.9 GW as in [36] and [38].

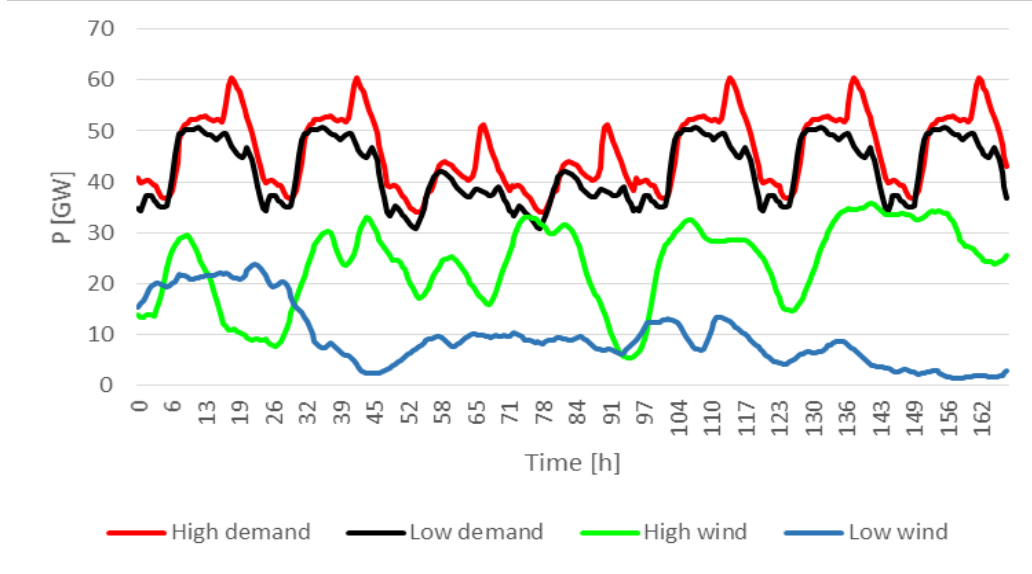

Figure 1 Demand and wind profiles for a period of one week

Secondary reserve can again be provided by all units in the system, conventional and EV. Although EV could also participate in tertiary reserve, due to their capability of reacting to fast system changes, they are considered only for spinning reserve service provision (primary and secondary reserve).

$$\sum_{i=1}^{N_{i\_TP}} f_{t,i}^{\text{up\_TP}} + \sum_{i=1}^{N_{i\_HP}} f_{t,i}^{\text{up\_HP}} + \sum_{i=1}^{N_{i\_PS}} f_{t,i}^{\text{up\_PS}} + \sum_{i=1}^{N_{i\_EV}} f_{t,i}^{\text{up\_EV}} \geq F_t^{\text{up}} \quad (3)$$

$$\sum_{i=1}^{N_{i\_TP}} f_{t,i}^{\text{dn\_TP}} + \sum_{i=1}^{N_{i\_HP}} f_{t,i}^{\text{dn\_HP}} + \sum_{i=1}^{N_{i\_PS}} f_{t,i}^{\text{dn\_PS}} + \sum_{i=1}^{N_{i\_EV}} f_{t,i}^{\text{dn\_EV}} \geq F_t^{\text{dn}} \quad (4)$$

$$\sum_{i=1}^{N_{i\_TP}} r_{t,i}^{\text{up\_TP}} + \sum_{i=1}^{N_{i\_HP}} r_{t,i}^{\text{up\_HP}} + \sum_{i=1}^{N_{i\_PS}} r_{t,i}^{\text{up\_PS}} + \sum_{i=1}^{N_{i\_EV}} r_{t,i}^{\text{up\_EV}} \geq R_t^{\text{up}} \quad (5)$$

$$\sum_{i=1}^{N_{i\_TP}} r_{t,i}^{\text{dn\_TP}} + \sum_{i=1}^{N_{i\_HP}} r_{t,i}^{\text{dn\_HP}} + \sum_{i=1}^{N_{i\_PS}} r_{t,i}^{\text{dn\_PS}} + \sum_{i=1}^{N_{i\_EV}} r_{t,i}^{\text{dn\_EV}} \geq R_t^{\text{dn}} \quad (6)$$

$$\sum_{i=1}^{N_{i\_TP}} q_{t,i}^{\text{up\_TP}} \geq Q_t^{\text{up}} \quad (7)$$

Secondary and tertiary reserve values are defined as time vectors that depend on the electrical demand (taking into account variability of demand through standard deviations of load forecast  $\sigma^d$ ), wind power production (taking into account uncertainty and variability of wind generation modelled as standard deviation of wind forecast  $\sigma^{(0,5h)\_WP}$  and  $\sigma^{(4h)\_WP}$ ) and EV's charging mode (taking into account a fixed value describing uncertain nature of EV arrival and battery SOC through variables  $R^{\text{EV}_{0,5h}}$  and  $R^{\text{EV}_{4h}}$ ), as well as the outage of the largest generating unit  $P^{\text{gmax}}$ . Modelling of secondary and tertiary reserve is taken from [39] and described by (8) – (12):

$$R_t^{EV\_0,5h} = \sum_{i=1}^{Ni\_EV} \left( 3,5 * \sigma_t^{sl(0,5h)\_EV} * P_i^{max\_EV} * \sum_{\tau=t}^{(t-C_i^{UCH\_EV}+1)} N_{\tau,i}^{arr\_EV} \right) \quad (8)$$

$$R_t^{EV\_4h} = \sum_{i=1}^{Ni\_EV} \left( 3,5 * \sigma_t^{sl(4h)\_EV} * P_i^{max\_EV} * \sum_{\tau=t}^{(t-C_i^{UCH\_EV}+1)} N_{\tau,i}^{arr\_EV} \right) \quad (9)$$

$$R_t^{up} = \sqrt{(3 * \sigma^d * P_t^d)^2 + (3,5 * \sigma_t^{(0,5h)\_WP} * P_t^{WP})^2 + (R_t^{EV\_0,5h})^2} + P^{gmax} \quad (10)$$

$$R_t^{dn} = \sqrt{(3 * \sigma^d * P_t^d)^2 + (3,5 * \sigma_t^{(0,5h)\_WP} * P_t^{WP})^2 + (R_t^{EV\_0,5h})^2} \quad (11)$$

$$Q_t^{up} = \sqrt{(3 * \sigma^d * P_t^d)^2 + (3,5 * \sigma_t^{(4h)\_WP} * P_t^{WP})^2 + (R_t^{EV\_4h})^2} + P^{gmax} \quad (12)$$

Modelling technical limitation of fossil fuel based power plants is taken from recent publications [40], [41] and [42] where thermal units are subjected to the following constraints: power generation constraints (piece-wise linear cost curve), minimum up and down times, ramping constraints, reserve provision constraints (primary, secondary and tertiary), greenhouse gas emissions (included as additional cost in objective function). In addition, hydro power plants are modelled similar to the models in [43] and [44]. Details on input parameters of power plants is given in Table 1.

Table 1 Input values and constraints of fossil fuel driven generation units

Technology	$P_{min}$ [MW]	$E_{11}$ [MW]	$E_{12}$ [MW]	$P_{max}$ [MW]	$C_{n1}$ [\$/h]	$C_{in1}$ [\$/MWh]	$C_{in2}$ [\$/MWh]	$C_{in3}$ [\$/MWh]	$C_{st}$ [\$]	$C_{sh}$ [\$]	$T_{up}$ [h]
Nuclear	400	400	400	400	260,86	12,093	12,663	13,233	750	75	16
Coal	140	210	280	350	199,43	17,0805	17,3955	17,7105	450	45	8
CCGT	68,9	111,6	154,3	197	359,48	35,3535	35,6865	36,0195	300	30	5
OCGT	4	9,3	14,7	20	176,92	56,937	57,1545	57,3735	46	4,6	0,5
	$T_{dn}$ [h]	$V_{up}$ [MW/h]	$V_{dn}$ [MW/h]	$P_0$ [MW]	$N_0$	$RHO_{up}$	$RHO_{dn}$	$F_{iup}$ [MW]	$F_{idn}$ [MW]	Emiss. (kgC O <sub>2</sub> /M Wh)	Start Emiss. rate (kgCO <sub>2</sub> )
Nuclear	10	50,5	100	12000	30	0,5	0,5	40	40	0	0
Coal	5	70	120	10500	30	0,4	0,4	35	35	925	25000
CCGT	4	55	99	0	0	0,6	0,6	19,7	19,7	394	8000
OCGT	0,5	30,5	70	0	0	0,7	0,7	2	2	600	3000

Mathematical models of all EV operational regimes are shown in [19] where 6 different concepts are presented, depending on controllability of EV and number of services these units provide. In this paper only a description of selected operating regimes used in the simulations is provided for understanding specific charging/discharging concept. While in [19] detailed analysis of uncontrollable and controllable charging is given, in this paper only controllable charging is considered where EV provide multiple services (energy and reserve). However, a distinction between G2V (vehicle are “only” controllably charged) and V2G (vehicles can be controllably discharged, injecting electricity back to the system and providing additional value) is made. Only 2 out of 6 EV regimes are selected for the purpose of simulations in the following Sections:

- Controlled Grid-to-Vehicle charging with possibility to provide Reserve (G2V);
- Controlled Vehicle-to-Grid charging with possibility to provide Reserve (V2G).

Input values and constraints for EV modelling are given in Table 2.

Table 2 Input values and constraints of EV

Input parameter		Personal vehicle
$P_{min}$ [kW]		0,2
$P_{max}$ [kW]		2
$S_{min}$ [kWh]		4
$S_{max}$ [kWh]		20
$S_{minc}$ [kWh]		20
$\eta_c, \eta_d$		0,95
$P_{fmax}$ [kW]		50
Range [km]	short	20
	medium	40
	long	80
Consumed energy per trip [kWh]	short	4
	medium	8
	long	16
Percentage of EVs type and range in total number of EVs	short	82%
	medium	10%
	long	8%

## WEEKLY OPERATIONAL ANALYSES

To define how the role of specific unit changes in systems with high wind penetration, weekly analyses of the system operation are run for several relevant scenarios. The focus is put on provision of energy as well as primary and secondary reserve, including participation of EVs in all these services. Two scenarios, one with no wind integrated in the system and the one where wind contributes to 20% of total energy produced, are further analysed for 3 different EV cases:

- No electric vehicles integrated;
- G2V scenario: Electric vehicles can only be charges, meaning they act as controllable loads. Following conclusions from [19] EV can provide both energy and reserve services;
- V2G scenario: Electric vehicles can be both controllably charged and discharged providing energy and reserve services and adding to the system flexibility.

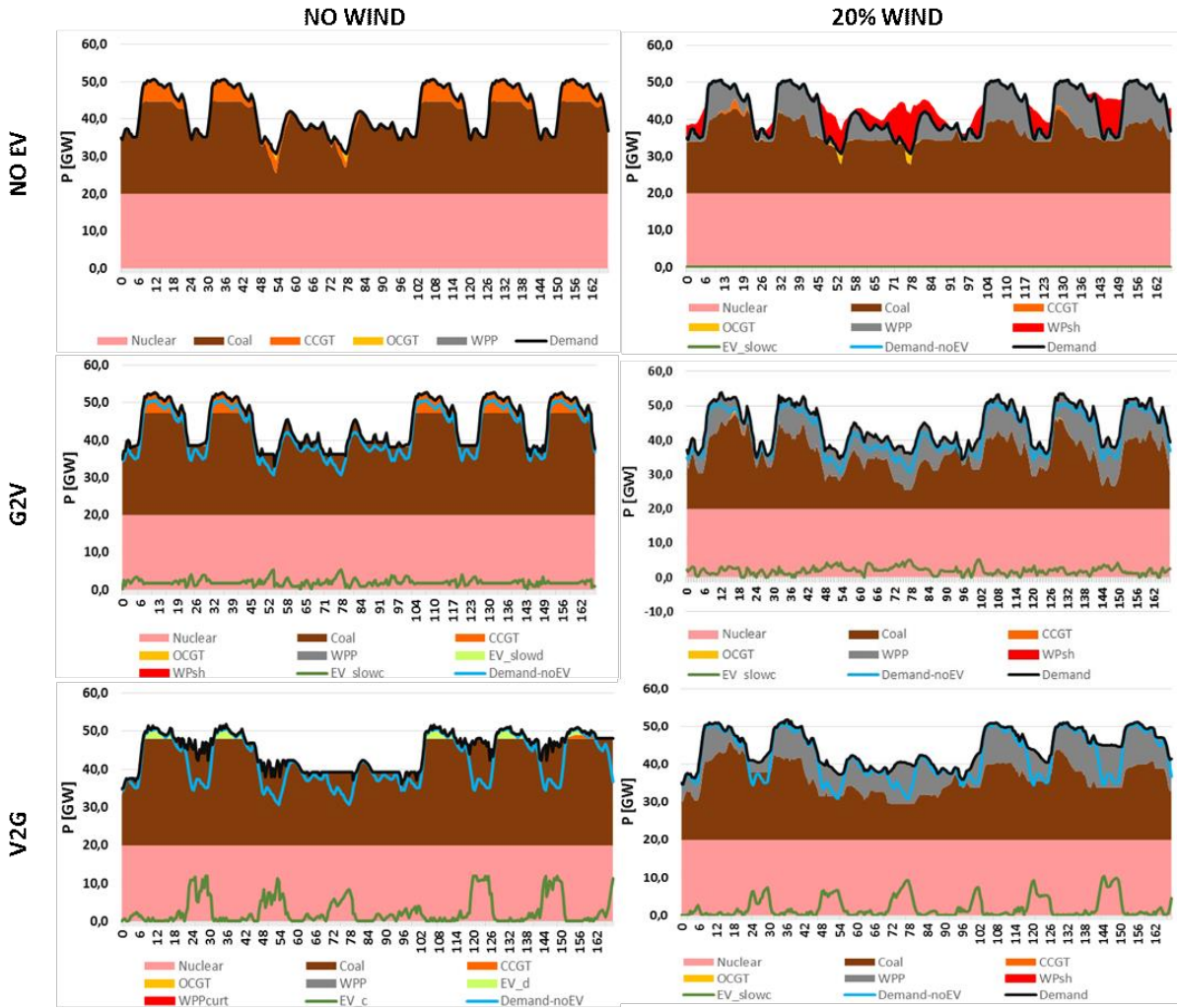

Figure 2 Energy service scheduling in different wind and EV scenarios

Figure 2 shows the results of power system dispatch for a period of one week, in particular which units provide energy service in each of the 6 analysed cases. The layout of the figure enables comparing both the impact of wind integration and the impact of EV flexibility on provision of multiple services. Looking at the first two scenarios, where EVs are not included in provision of flexibility services (first “row” of Figure 2), it can be seen that the current system is not flexible enough and, to maintain the security of supply, wind is curtailed. Already in G2V case the curtailment is eliminated (second row of Figure 2) in both cases. In case where there is no wind, EV takes the role of fast responding units such as CCGT covering daily peak demand.

Figure 3 shows the provision of primary frequency response (PFR) for all scenarios. It should be noted that integration of wind does not directly affect the amount of primary reserve required, however due to different dispatching of units which provide secondary and tertiary reserve service, provision of PFR is assigned to the different units. Since EV have, due to their technical characteristics, the capability to respond to fast changes, the role of providing PFR switches from classical thermal units (coal and CCGT) to electric vehicles with the integration of EV and wind, in particular in cases where they can be controllably charged and discharged (V2G case). This mitigation of PFR service means thermal units operate more efficiently also reducing expensive units’ start-ups (e.g. CCGT, see Table 2), resulting in lower system operational cost.

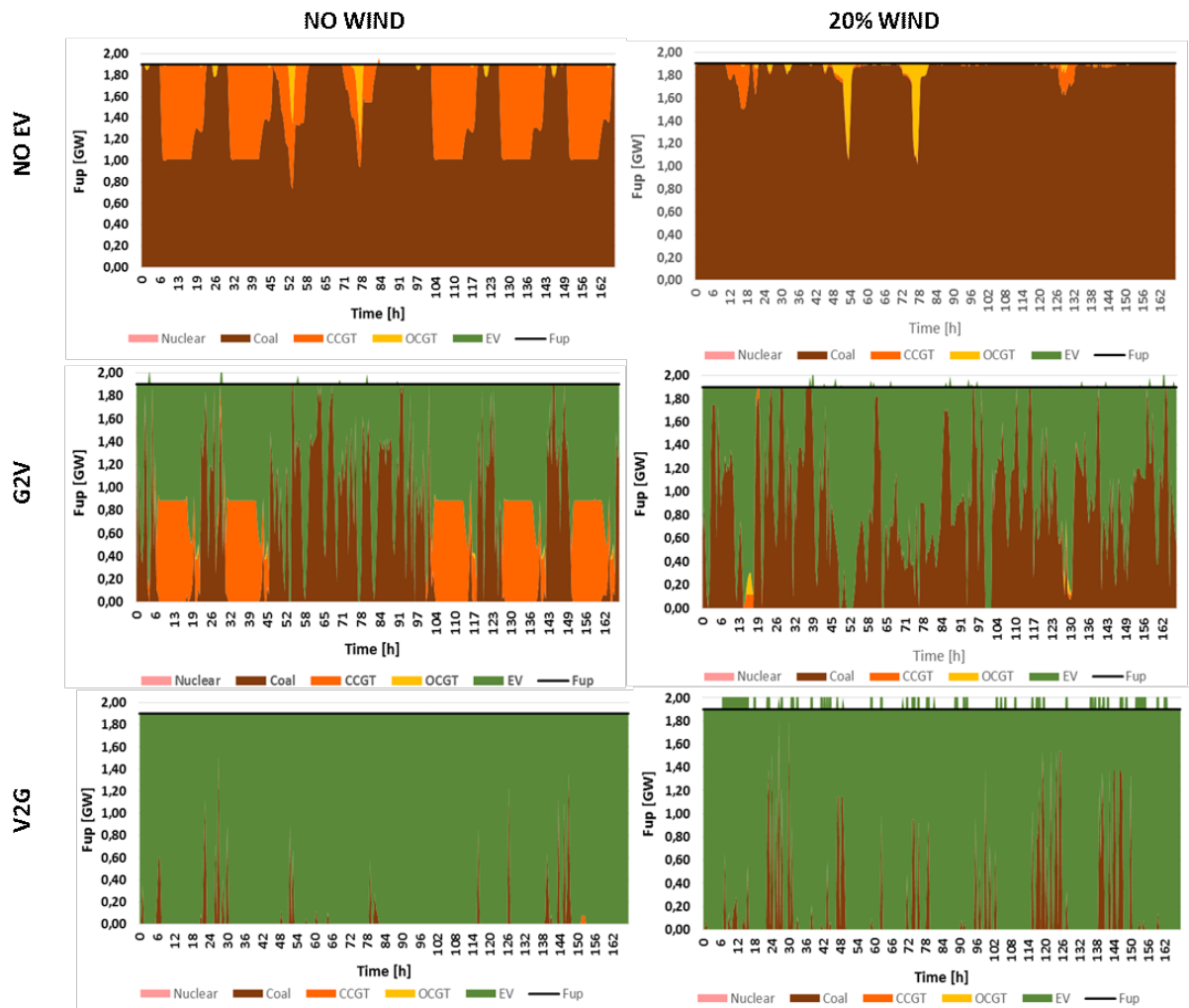

Figure 3 Results of scheduling primary frequency reserve service in different wind and EV scenarios

Provision of secondary reserve service (SFR) from specific units, is shown in Figure 4, for the above described scenarios of wind and flexible EV integration. Similar to PFR, EV take over the role in providing SFR from expensive CCGT units and, in case where they can provide additional flexibility by discharging, coal units.



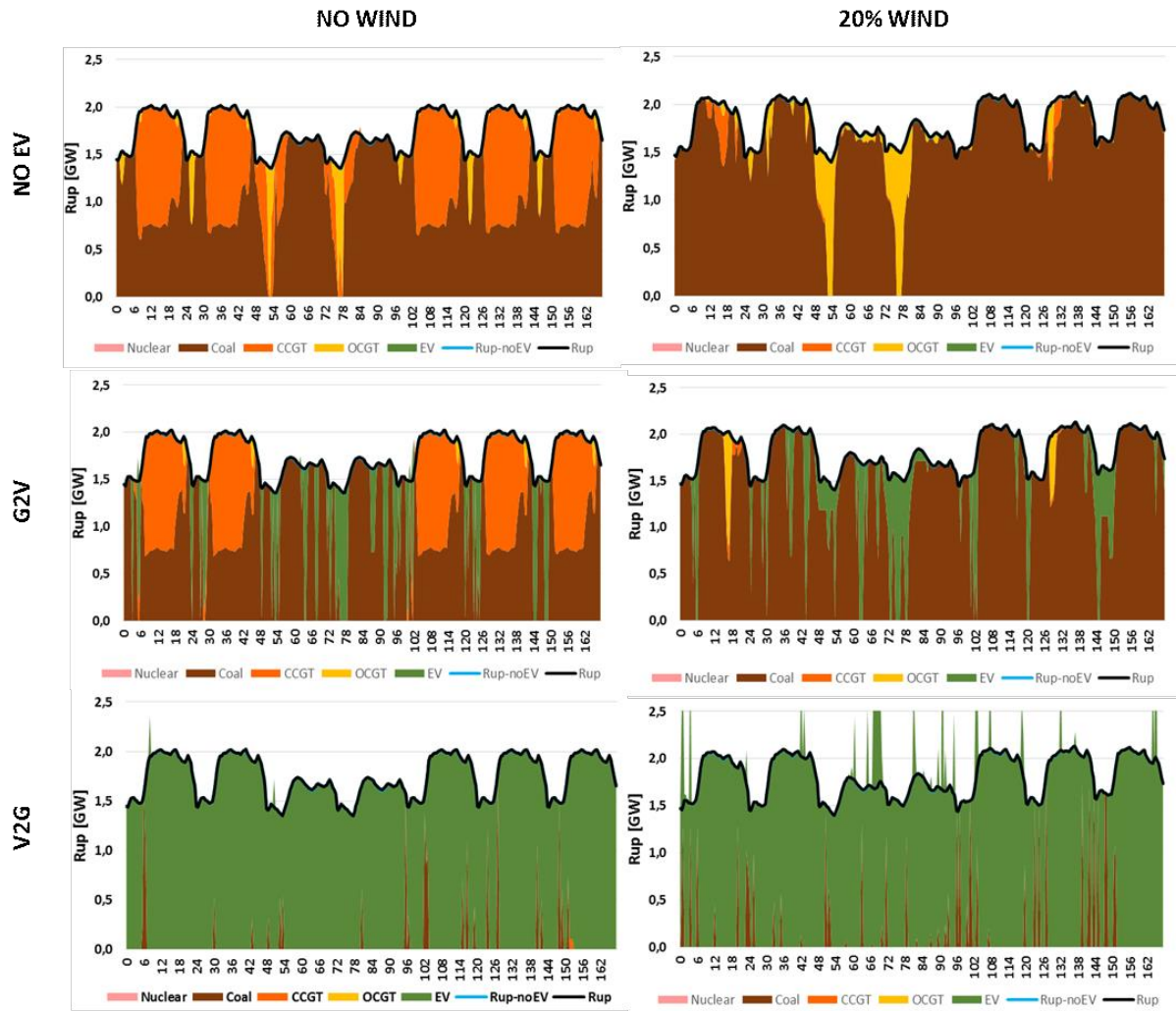

Figure 4 Results of scheduling secondary frequency reserve service in different wind and EV scenarios

To summarize; by integrating wind, the role of gas driven units is initially substituted by that of coal. Gas units are taking the role of standing reserve, since they are the most expensive ones and, since primary and secondary reserve needs to be provided by spinning units, coal units take the role of providing PFR and SFR. Furthermore in case when EVs have the capability to both charge and discharge they cover over 95% of PFR and SFR needs in the system while conventional units take over the role of solely providing energy and tertiary reserve service.

Integration of renewable energy sources and flexible technologies, especially on the distribution side, are often put in the context with replacement of conventional units such as high carbon intensity coal and low flexible nuclear power plants. Several strategies even suggest these units should be decommissioned with the interpretation that RES and LCT take over their role in the power system services. However, very little research has been done on how such actions reflect on total system operational cost and system's flexibility. In this paper insufficient flexibility is expressed as the curtailed wind energy. In the following Section a detailed analysis is provided answering these questions.

### IMPACT OF DIFFERENT UNITS IN FUTURE FLEXIBLE POWER SYSTEMS

The main idea of this Section is to analyse how decommissioning of conventional low flexible power plants, in case coal and nuclear, reflects on system operational cost and wind curtailment. It has been shown in Figure 2 that nuclear power plants serve as base load units and they are not scheduled for provision of reserve services nor for load following. Although NPP have the flexibility to ramp and respond to variability of the system, commonly they are, for security reasons, operated either on maximum power, at minimum stable generation point (MSG) or are offline. It should be noted that once NPP is shut down it takes between 24 and 48 hours to start it back again; each starting of NPP is expensive and these actions are thus avoided if possible. Although a bit more flexible, coal power plants, once shut down, cannot be put online for the next 4 to 6 hours (depending on the level of shut down; hot, warm or cold).

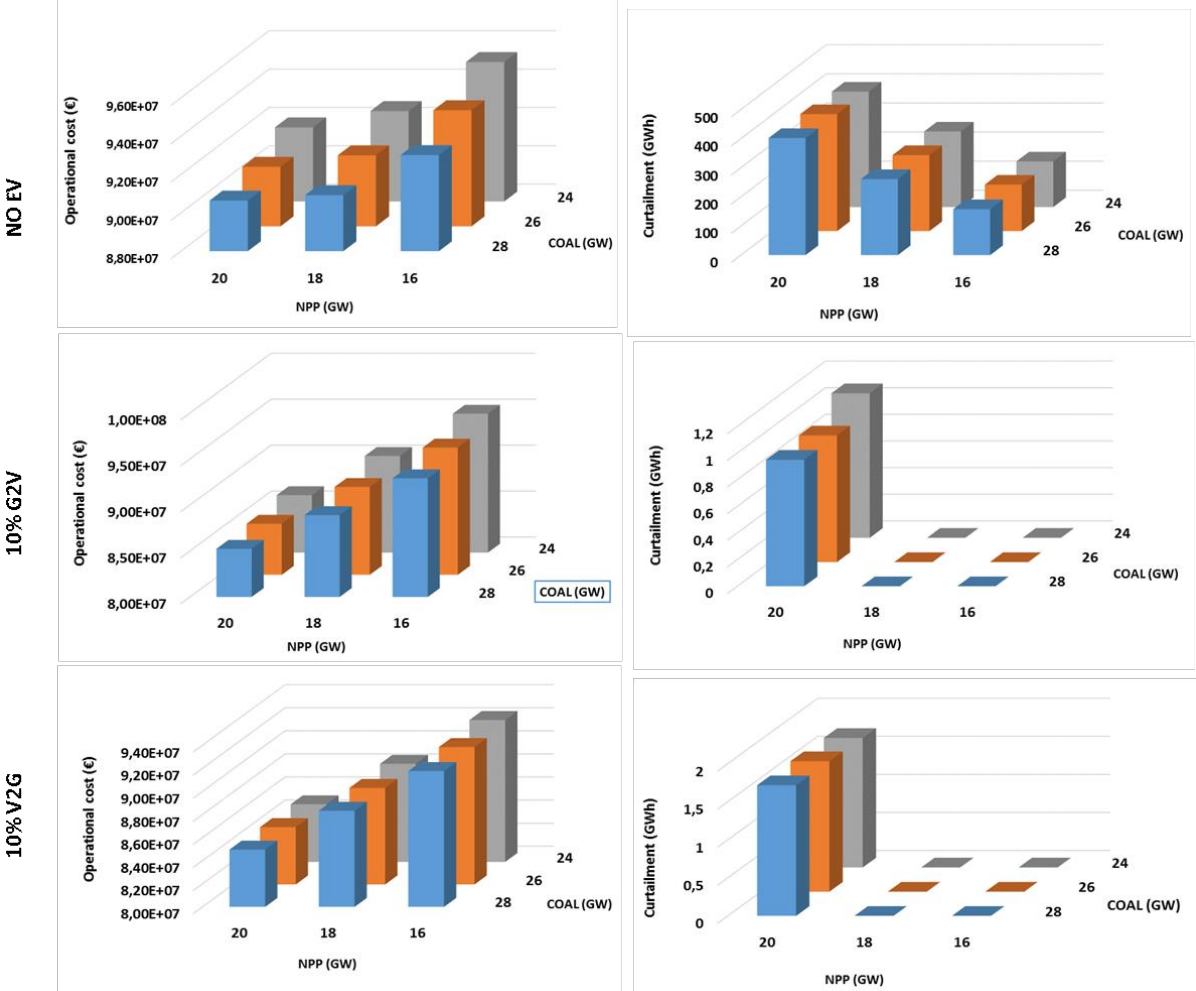

Figure 5 Power plant decommissionation analysis in power system with 20% wind energy

Figure 5 shows the effect of decommissioning coal and NPP for the same scenarios as in the previous Section. Universally the conclusion can be made that, by decommissioning either coal or NPP, curtailment of wind is reduced. It should be also noticed that, in scenarios with wind and EV integrated, curtailment of wind energy is already 300 times lower than without EV. On the other hand, decommissioning of NPP and coal significantly increases systems operational cost, while integration of controllable EV reduces system cost.

The same analysis is conducted for an even larger penetration of wind, doubling the share of wind energy to 40%. It is interesting to notice that with no EV in the system and with the 40% of wind, decommissioning of NPP and coal has a positive effect on both operational cost and wind

energy curtailed. On the other hand, integration of EV has a larger impact on wind curtailment reducing it almost 1000 times even without decommissioning NPP and coal power plants. The effect of operational cost increase can again be noticed when non flexible units are decommissioned, similar to the case with 20% of wind.

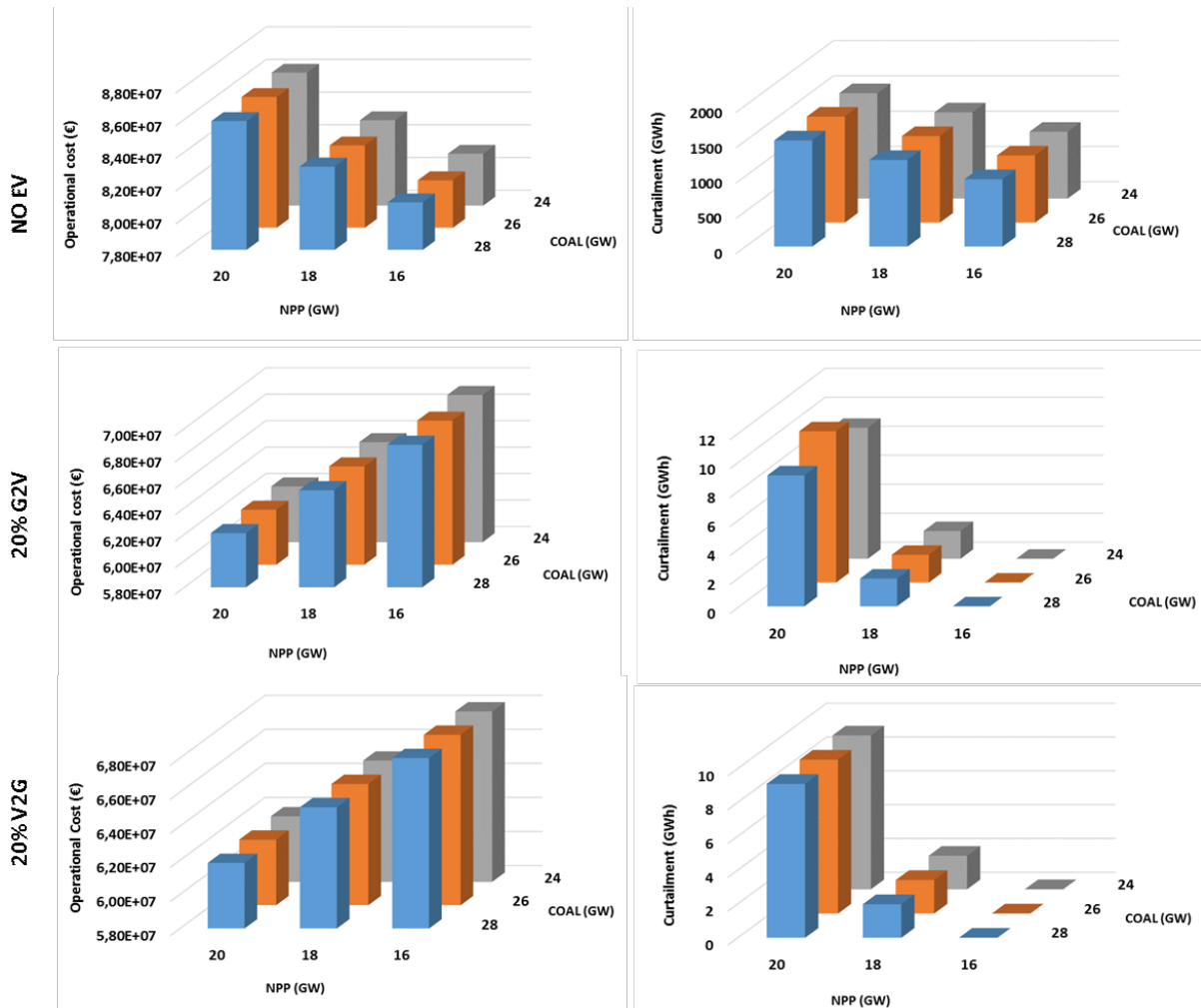

Figure 6 Power plant decommission analysis in power system with 40% wind energy

A general conclusion can be made that by decommissioning NPP and coal units the system flexibility increases, completely eliminating wind curtailment. However, and this in particular is valid for NPP, decommissioning the low cost base load units means that more expensive gas driven units take on the role of providing both energy and reserve services, cycling and increasing the number of their start-ups. This in turn results in total operational cost increase.

## CONCLUSION

The paper presents a mathematical model of power system operation capable of analysing systems flexibility and the impact of integrating renewable energy and flexible low carbon technologies, in this case EV. The model captures all technical characteristics and constraints of power system components, modelling different types of EV and different aspects of controllable charging/discharging where EV can provide multiple system services. In low flexible power systems, and usually highly carbon intensive, integration of controllable EVs has a positive effect on all aspects of power system operation, ranging from reduced operational cost, lower curtailed wind energy to lower carbon emissions due to more efficient operation of conventional units.

Their capability to respond to fast changes following systems variability and uncertainty means they take over the role that is traditionally assigned to coal and gas power plants in providing of PFR and SFR, resulting in lower operational cost and CO<sub>2</sub> emissions. Another aspect, reflecting more planning than operation aspect of future low carbon systems, is addressed by showing the effect of decommissioning coal and nuclear power plants in systems with high share of wind power plants and flexible EV. The results clearly show that, although the system in general becomes more flexible by lowering systems MSG and increasing its ramping capability, the positive effects of reduced wind curtailment is followed by increase in systems operational cost. This occurs due to increased utilization of gas units, their cycling behaviour and high start-up costs.

## ACKNOWLEDGMENT

The work of the authors is a part of the project FENISG - Flexible Energy Nodes in Low Carbon Smart Grid funded by Croatian Science Foundation under project grant No. 7766.

## NOMENCLATURE

### Decision variables

$P_{t,i}^{g\_TP}$	Thermal units generation
$P_{t,i}^{g\_HP}$	Hydro units generation
$P_{t,i}^{g\_PS}$	Pump storage generation/pumping
$P_{t,i}^{p\_PS}$	Pump storage pumping
$P_t^{g\_WP}$	Wind power generation
$P_{t,i}^{c\_EV}$ , $P_{t,i}^{d\_EV}$	Electric vehicles slow charging/discharging
$P_{t,i}^{f\_EV}$	Electric vehicles fast charging
$f_{t,i}^{up\_TP}$ , $f_{t,i}^{dn\_TP}$ , $r_{t,i}^{up\_TP}$ , $r_{t,i}^{dn\_TP}$	Thermal units primary(f)/secondary(r) up/down reserve provision
$f_{t,i}^{up\_HP}$ , $f_{t,i}^{dn\_HP}$ , $r_{t,i}^{up\_HP}$ , $r_{t,i}^{dn\_HP}$	Hydro units primary(f)/secondary(r) up/down reserve provision
$f_{t,i}^{up\_PS}$ , $f_{t,i}^{dn\_PS}$ , $r_{t,i}^{up\_PS}$ , $r_{t,i}^{dn\_PS}$	Pump storage primary(f)/secondary(r) up/down reserve provision
$f_{t,i}^{up\_EV}$ , $f_{t,i}^{dn\_EV}$ , $r_{t,i}^{up\_EV}$ , $r_{t,i}^{dn\_EV}$	Electric vehicles primary(f)/secondary(r) up/down reserve provision
$q_{t,i}^{up\_TP}$	Thermal units tertiary up reserve provision
$c_{t,i}^{TP}$	Total thermal power plant cost
$c_{t,i}^{HP}$	Total hydro power plant cost

### Input parameters

$P_t^d$	Power demand
$F_t^{up}$	Primary up reserve requirements
$F_t^{dn}$	Primary down reserve requirements
$R_t^{up}$	Secondary up reserve requirements
$R_t^{dn}$	Secondary down reserve requirements

$Q_t^{\text{up}}$	Tertiary up reserve requirements
$P_t^{\text{-WP}}$	Potential wind power generation
$R_t^{\text{EV}_{0,5h}}, R_t^{\text{EV}_{4h}}$	Secondary and tertiary reserve requirements increase caused by uncontrolled EVs charging
$\sigma_t^{\text{sl}(0,5h)\text{-EV}}, \sigma_t^{\text{sl}(4h)\text{-EV}}$	EVs uncontrolled charging standard deviation for secondary and tertiary reserve
$\sigma_t^{(0,5h)\text{-WP}}, \sigma_t^{(4h)\text{-WP}}$	Wind power standard deviation for secondary and tertiary reserve

### Input parameters

$N_{i\_TP}$	Number of thermal technology types
$N_{i\_HP}$	Number of hydro technology types
$N_{i\_PS}$	Number of pump storage technology types
$N_{i\_EV}$	Number of electric vehicles types
$\sigma^d$	Power demand standard deviation
$p^{\text{gmax}}$	The largest online unit in power system
$\Delta t$	Time period (0,5 h) for energy calculation
$S_i^0\text{-EV}$	Energy conserved in (all) EVs in time step zero

### Abbreviations

CCGT	Combined Cycle Gas Turbine
HPP	Hydro Power Plant
EPS	Electric Power System
ES	Energy Storage
EV	Electric Vehicle
G2V	Grid-to-Vehicle
HP	Hydro Power
LCT	Low Carbon Technologies
MILP	Mixed Integer Linear Programming
NPP	Nuclear Power Plants
OCGT	Open Cycle Gas Turbine
PS	Pump Storage
RES	Renewable Energy Sources
TP	Thermal Power
TSC	Total System Cost
TSE	Total System Emissions
UC	Unit Commitment
V2G	Vehicle-to-Grid
WPP	Wind Power Plant

### **REFERENCES**

- [1] M. a. Ortega-Vazquez, D.S. Kirschen, Estimating the Spinning Reserve Requirements in Systems With Significant Wind Power Generation Penetration, IEEE Trans. Power Syst. 24 (2009) 114–124. doi:10.1109/TPWRS.2008.2004745.
- [2] M. a. Ortega-Vazquez, F. Bouffard, V. Silva, Electric Vehicle Aggregator/System Operator Coordination for Charging Scheduling and Services Procurement, IEEE Trans. Power Syst. 28 (2013) 1806–1815. doi:10.1109/TPWRS.2012.2221750.

- [3] J. Ryan, E. Ela, D. Flynn, M. O'Malley, Variable Generation, Reserves, Flexibility and Policy Interactions, in: 47th Hawaii Int. Conf. Syst. Sci., Ieee, 2014: pp. 2426–2434. doi:10.1109/HICSS.2014.304.
- [4] D. Papadaskalopoulos, G. Strbac, P. Mancarella, M. Aunedi, V. Stanojevic, Decentralized Participation of Flexible Demand in Electricity Markets—Part II: Application With Electric Vehicles and Heat Pump Systems, *IEEE Trans. Power Syst.* 28 (2013) 3667–3674. doi:10.1109/TPWRS.2013.2245687.
- [5] M. Black, G. Strbac, Value of Bulk Energy Storage for Managing Wind Power Fluctuations, *IEEE Trans. Energy Convers.* 22 (2007) 197–205.
- [6] D. Pudjianto, M. Aunedi, P. Djapic, G. Strbac, Whole-Systems Assessment of the Value of Energy Storage in Low-Carbon Electricity Systems, *IEEE Trans. Smart Grid.* 5 (2014) 1098–1109. [http://ieeexplore.ieee.org/xpls/abs\\_all.jsp?arnumber=6612755](http://ieeexplore.ieee.org/xpls/abs_all.jsp?arnumber=6612755) (accessed March 21, 2014).
- [7] H. Pandžić, Y. Wang, T. Qiu, D.S. Kirschen, Near-Optimal Method for Siting and Sizing of Distributed Storage in a Transmission Network, *IEEE Trans. Power Syst.* PP (2014) 1–13.
- [8] E. Karangelos, F. Bouffard, Towards Full Integration of Demand-Side Resources in Joint Forward Energy/Reserve Electricity Markets, *IEEE Trans. Power Syst.* 27 (2012) 280–289. doi:10.1109/TPWRS.2011.2163949.
- [9] G. Gross, Key Issues and Challenges in the Deepening Penetration of Demand Response Resources, 2014.
- [10] T. Li, M. Shahidehpour, Price-Based Unit Commitment: A Case of Lagrangian Relaxation Versus Mixed Integer Programming, *IEEE Trans. Power Syst.* 20 (2005) 2015–2025.
- [11] M. Carrión, J.M. Arroyo, A Computationally Efficient Mixed-Integer Linear Formulation for the Thermal Unit Commitment Problem, *IEEE Trans. Power Syst.* 21 (2006) 1371–1378.
- [12] Y. Dvorkin, H. Pandžić, M.A. Ortega-vazquez, D.S. Kirschen, A Hybrid Stochastic / Interval Approach to Transmission-Constrained Unit Commitment, *IEEE Trans. Power Syst.* PP (2014) 1–11.
- [13] P. Meibom, R. Barth, B. Hasche, H. Brand, C. Weber, M. O'Malley, Stochastic Optimization Model to Study the Operational Impacts of High Wind Penetrations in Ireland, *IEEE Trans. Power Syst.* 26 (2011) 1367–1379. doi:10.1109/TPWRS.2010.2070848.
- [14] A. Sturt, G. Strbac, Efficient Stochastic Scheduling for Simulation of Wind-Integrated Power Systems, *IEEE Trans. Power Syst.* 27 (2012) 323–334. doi:10.1109/TPWRS.2011.2164558.
- [15] B.S. Palmintier, Incorporating Operational Flexibility into Electric Generation Planning, Massachusetts Institute of Technology, 2013.
- [16] B.S. Palmintier, M.D. Webster, Heterogeneous Unit Clustering for Efficient Operational Flexibility Modeling, *IEEE Trans. Power Syst.* 29 (2014) 1089–1098.
- [17] J. Kiviluoma, P. Meiborn, Methodology for modelling plug-in electric vehicles in the power system and cost estimates for a system with either smart or dumb electric vehicles, *Energy.* 36 (2011) 1758–1769.
- [18] R. Barth, H. Brand, P. Meiborn, C. Weber, A stochastic unit-commitment model for the evaluation of the impacts of integration of large amounts of intermittent wind power, in: 9th Int. Conf. Probabilistic Methods Appl. to Power Syst. PMAPS, 2006: pp. 1–6.

- [19] I. Pavić, T. Capuder, I. Kuzle, Value of flexible electric vehicles in providing spinning reserve services, *Appl. Energy*. 157 (2015) 60–74. doi:10.1016/j.apenergy.2015.07.070.
- [20] B.C. Ummels, M. Gibescu, E. Pelgrum, W.L. Kling, A.J. Brand, Impacts of Wind Power on Thermal Generation Unit Commitment and Dispatch, *IEEE Trans. Energy Convers.* 22 (2007) 44–51. doi:10.1109/TEC.2006.889616.
- [21] M.L. Kubik, P.J. Coker, J.F. Barlow, Increasing thermal plant flexibility in high renewables power system, *Appl. Energy*. 154 (2015) 102–111.
- [22] P. Denholm, M. Hand, Grid flexibility and storage required to achieve very high penetration of variable renewable electricity, *Energy Policy*. 39 (2011) 1817–1830.
- [23] G. Krajačić, N. Duić, M. Carvalho, How to achieve a 100% RES electricity supply for Portugal?, *Appl. Energy*. 88 (2011) 508–517.
- [24] G. Krajačić, N. Duić, Z. Zmijarević, B.V. Mathiesen, A. Anić Vučinić, M. Carvalho, Planning for a 100% independent energy system based on smart energy storage for integration of renewables and CO2 emissions reduction, *Appl. Therm. Eng.* 31 (2011) 2073–2083.
- [25] B. Čosić, G. Krajačić, N. Duić, A 100% renewable energy system in the year 2050: the case of Macedonia, *Energy*. 48 (2012) 80–87.
- [26] B. Tarroja, B. Shaffer, S. Samuelsen, The importance of grid integration for achievable greenhouse gas emissions reductions from alternative vehicle technologies, *Energy*. 87 (2015) 504–519.
- [27] D. Božić, M. Pantoš, Impact of electric-drive vehicles on power system reliability, *Energy*. In Press (2015) 1–10.
- [28] D.S. Kirschen, J. Ma, V. Silva, R. Belhomme, Optimizing the flexibility of a portfolio of generating plants to deal with wind generation, 2011 IEEE Power Energy Soc. Gen. Meet. (2011) 1–7. doi:10.1109/PES.2011.6039157.
- [29] J. Ma, V. Silva, R. Belhomme, D.S. Kirschen, L.F. Ochoa, Evaluating and Planning Flexibility in Sustainable Power Systems, *IEEE Trans. Sustain. Energy*. 4 (2013) 200–209.
- [30] B. Palmintier, Flexibility in generation planning: Identifying key operating constraints, in: *Power Syst. Comput. Conf. 2014*, 2014: pp. 1–7.
- [31] A. Shortt, M.O. Malley, Quantifying the Long-Term Impact of Electric Vehicles on the Generation Portfolio, *IEEE Trans. Smart Grid*. 5 (2014) 71–83.
- [32] ENTSO-E WG Ancillary Services, Ancillary Services in Europe Contractual aspects, 2011. [www.entsoe.eu/fileadmin/user\\_upload/\\_library/position\\_papers/ENTSO\\_BalancingMaps\\_Final.pdf](http://www.entsoe.eu/fileadmin/user_upload/_library/position_papers/ENTSO_BalancingMaps_Final.pdf).
- [33] F.D. Galiana, F. Bouffard, J.M. Arroyo, J.F. Restrepo, Scheduling and Pricing of Coupled Energy and Primary, Secondary, and Tertiary Reserves, *Proc. IEEE*. 93 (2005) 1970–1983.
- [34] M. Aunedi, Value of Flexible Demand-Side Technologies in Future Low-Carbon Systems, Imperial College London, 2013.
- [35] V. Silva, Value of flexibility in systems with large wind penetration, University of London, 2010.
- [36] R. Gross, T. Green, M. Leach, J. Skea, P. Heptonstall, D. Anderson, The Costs and Impacts of Intermittency, 2006. doi:10.1016/j.enpol.2008.06.013.
- [37] National Grid, Winter Outlook 2013/14, 2013.
- [38] F. Teng, V. Trovato, G. Strbac, Stochastic Scheduling With Inertia-Dependent Fast Frequency Response Requirements, *IEEE Trans. Power Syst.* PP (2015) 1–10.

- [39] J. Ma, V. Silva, R. Belhomme, D.S. Kirschen, L.F. Ochoa, Evaluating and planning flexibility in sustainable power systems, in: 2013 IEEE Power Energy Soc. Gen. Meet., IEEE, 2013: pp. 1–11. doi:10.1109/PESMG.2013.6672221.
- [40] H. Quan, D. Srinivasan, A.M. Khambadkone, A. Khosravi, A computational framework for uncertainty integration in stochastic unit commitment with intermittent renewable energy sources, *Appl. Energy*. 152 (2015) 71–82. doi:10.1016/j.apenergy.2015.04.103.
- [41] D.K. Dimitroulas, P.S. Georgilakis, A new memetic algorithm approach for the price based unit commitment problem, *Appl. Energy*. 88 (2011) 4687–4699. doi:10.1016/j.apenergy.2011.06.009.
- [42] J. Wang, J. Wang, C. Liu, J.P. Ruiz, Stochastic unit commitment with sub-hourly dispatch constraints, *Appl. Energy*. 105 (2013) 418–422. doi:10.1016/j.apenergy.2013.01.008.
- [43] I. Pavic, T. Capuder, N. Holjevac, I. Kuzle, Role and Impact of Coordinated EV Charging on Flexibility in Low Carbon Power Systems, in: *IEEE Int. Electr. Veh. Conf. 2014*, 2014: pp. 1–5.
- [44] C.G. Baslis, A.G. Bakirtzis, Optimal yearly scheduling of generation and pumping for a price-maker hydro producer, in: 2010 7th Int. Conf. Eur. Energy Mark., IEEE, 2010: pp. 1–6. doi:10.1109/EEM.2010.5558685.





## Publication 11

I. Pavić, T. Capuder, and I. Kuzle, “Fast charging stations — Power and ancillary services provision,” in *2017 IEEE Manchester PowerTech*, IEEE, Jun. 2017, pp. 1–6, ISBN: 978-1-5090-4237-1. DOI: 10.1109/PTC.2017.7981190

# Fast Charging Stations - Power and Ancillary Services Provision

Ivan Pavić<sup>1,\*</sup>, Tomislav Capuder<sup>2</sup> and Igor Kuzle<sup>3</sup>

<sup>1,2,3</sup> University of Zagreb, Faculty of Electrical Engineering and Computing,, Unska 3, 10000 Zagreb, Croatia

\*Corresponding author

**Abstract**—High penetration of variable renewable sources act as a heavy burden on conventional power system management and operation. Uncertainty in power systems expanded from demand side to generation side as well. Since new sources of imbalances have entered power system, it should be reorganized, automated and modernized. New providers of flexibility should be recognized and used in future power system planning and design. One of the possible technologies that can be used for flexibility provision are electric vehicles. Numerous fast charging stations are installed all over the world and such trend will continue in future. Depending on their operation, charging stations can act as flexibility providers but they can also further degrade system's flexibility if installed without any kind of energy buffer. This paper will present mixed integer linear model for flexibility studies of modern power systems with high penetration of variable renewable sources and electric vehicles. Results clearly show that smart planning of fast charging infrastructure can bring huge benefits to power system concerning costs, emissions, and variable renewable power curtailment.

**Keywords**—renewable energy sources; electric vehicles; fast charging stations; flexibility; ancillary services

## I. INTRODUCTION

New technologies integrated in power system introduced new problems to conventional power system operation. Due to their variability and unpredictability renewable energy sources brought new stochastic variables on generation side [1], [2]. New electricity loads such as electric vehicles or heat pumps [3], when uncontrolled, can also intensify uncertainty of power demand and cause increase in peak demand. In order to balance mentioned new power system state with huge number of stochastic variables, new fast responding generating units should be installed. Installment of such units, usually expensive gas turbines, is contrary to the initial plan where renewable generation should replace fossil fueled units. Advanced methods for system flexibility increase can be recognized in energy storage installment [4] or in usage of demand response programs [5]. Interesting way to decrease stochastic impact of variable renewable sources (VRE) on power system is to balance their generation locally and to use rest of the grid just when local generation is insufficient – microgrids [6].

This paper aims to present mixed integer linear programming (MILP) model with VRE, conventional power plants and incorporated fast charging stations. Also, goal is to examine impacts of fast charging stations (FCS) on power systems operation and flexibility. Different operating regimes provide insight in wide range of impacts on power system.

Flexibility of the power system can be defined as a competence of system to adequately balance power supply and power demand. Ancillary services are supporting services required by power system to enable continuous and stable flow of electricity from producer to consumer. Even though the term is used to refer to variety of operations, in this paper it is referring to reserve provision only.

A lot of recent literature have been published with the topic of FCS impact on power system, short overview is presented in the following. A revenue model of FCS has been developed in [7]. Authors propose that FCS sets the limit on EV required state-of-charge (SOC) in order to boost its revenue. Control of FCS with bidirectional power capabilities is proposed in [8]. A multi-objective planning strategy for FCS is developed in [9] where the overall annual cost of investment and energy losses are minimized simultaneously with the maximization of the annual traffic flow captured by FCS. Research paper [10] presents FCS load behavior model and uses it to asses impacts of FCS on distribution system where high accuracy of model has been proven. Authors in [11] propose a multi-objective FCS planning method which can ensure charging service while reducing power losses and voltage deviations of distribution system. FCS placement problem was solved in [12], while [13] tackles with simultaneous planning and sizing both DG and FCS as complementary technologies. Numerous papers such as [14], [15] study FCS placement in regards to driving behavior and other aspects (transmission grid, transportation grid, other social aspects etc.). Interesting economic aspect on competition of different FCS in modern EPS has been published in [16], while [17] deals with a business and operating model of EV battery swapping stations (BSS). As seen through this paragraph a great deal of recent publications provides research about FCS from planning, siting, sizing through FCS load behavior and distribution system impact assessments to economic aspects such as maximization of FCS revenues and business models. None of them deals with the impacts of FCS on the unit commitment of conventional generators, ancillary services nor with on the combined impacts of Slow charging EV (SEV) and FCS.

Rest of the paper is structured as following. Section II explains proposed model, Section III discusses gained results and last Section concludes with most important findings.

## II. MODEL

Proposed model used for EV flexibility in this paper has been divided between power generation and demand. Generation is composed of conventional fossil fueled (Nuclear, Coal,

Combined and Opened Cycle Gas Turbines) and hydro power plants (Run of River, Accumulation Hydro, Pump Storage) and Variable Renewable Energy Sources. Demand is composed of Electric Vehicles (EV) and Conventional Power Demand (CPD). The main balancing equation is generation-demand equation, i.e. generation and demand should be balanced at every time step as it is formulated in (1). Each of the variables contains superscript which specifies related technology (example, TP means Thermal Power).

$$\begin{aligned} & \sum_{i=1}^{Ni\_TP} (p_{t,i}^{g\_TP}) + \sum_{i=1}^{Ni\_HP} (p_{t,i}^{g\_HP}) + \sum_{i=1}^{Ni\_PS} (p_{t,i}^{g\_PS} - p_{t,i}^{p\_PS}) + p_t^{g\_WP} = \\ & P_t^d + \sum_{i=1}^{Ni\_EV} (p_{t,i}^{c\_EV} - p_{t,i}^{d\_EV}) + \sum_{i=1}^{Ni\_FCS} (p_{t,i}^{c\_FCS} - p_{t,i}^{d\_FCS}) \end{aligned} \quad (1)$$

Other type of balancing equations are reserve provision-requirements for primary, secondary, and tertiary reserve. Equations (2) - (3) correspond to primary reserve up and down, equations (4) - (5) to secondary reserve up and down and (6) to tertiary up reserve.

$$\sum_{i=1}^{Ni\_TP} f_{t,i}^{up\_TP} + \sum_{i=1}^{Ni\_HP} f_{t,i}^{up\_HP} + \sum_{i=1}^{Ni\_EV} f_{t,i}^{up\_EV} + \sum_{i=1}^{Ni\_FCS} f_{t,i}^{up\_FCS} \geq F_t^{up} \quad (2)$$

$$\sum_{i=1}^{Ni\_TP} f_{t,i}^{dn\_TP} + \sum_{i=1}^{Ni\_HP} f_{t,i}^{dn\_HP} + \sum_{i=1}^{Ni\_EV} f_{t,i}^{dn\_EV} + \sum_{i=1}^{Ni\_FCS} f_{t,i}^{dn\_FCS} \geq F_t^{dn} \quad (3)$$

$$\sum_{i=1}^{Ni\_TP} r_{t,i}^{up\_TP} + \sum_{i=1}^{Ni\_HP} r_{t,i}^{up\_HP} + \sum_{i=1}^{Ni\_EV} r_{t,i}^{up\_EV} + \sum_{i=1}^{Ni\_FCS} r_{t,i}^{up\_FCS} \geq R_t^{up} \quad (4)$$

$$\sum_{i=1}^{Ni\_TP} r_{t,i}^{dn\_TP} + \sum_{i=1}^{Ni\_HP} r_{t,i}^{dn\_HP} + \sum_{i=1}^{Ni\_EV} r_{t,i}^{dn\_EV} + \sum_{i=1}^{Ni\_FCS} r_{t,i}^{dn\_FCS} \geq R_t^{dn} \quad (5)$$

$$\sum_{i=1}^{Ni\_TP} q_{t,i}^{up\_TP} \geq Q_t^{up} \quad (6)$$

Reserve requirements (right side of the equations (4) - (6)) are calculated through equations (7) - (11). These equations are not part of optimization algorithm, they are calculated a priori based on historical data.

$$R_t^{0.5\_EV} = \sum_{i=1}^{Ni\_EV} \left( 3,5 \cdot \sigma_i^{0.5h\_EV} \cdot P_i^{max\_EV} \cdot \sum_{\tau=t}^{(t-C^{UChl\_EV}+1)} N_{\tau,i}^{arr\_EV} \right) \quad (7)$$

$$R_t^{0.5\_FCS} = \sum_{i=1}^{Ni\_FCS} \left( 3,5 \cdot \sigma_i^{0.5h\_FCS} \cdot \frac{P_i^{max\_FCS}}{3} * (G_i^{EV} - N_{\tau,i}^{arr\_EV}) \cdot \frac{P_i^{perf\_EV}}{100} \right) \quad (8)$$

$$R_t^{up} = P_t^{gmax} + \sqrt{(3 \cdot \sigma^d \cdot P_t^d)^2 + (3,5 \cdot \sigma_i^{(0.5h)\_WP} \cdot P_i^{WP})^2 + (R_t^{0.5h\_EV})^2 + (R_t^{0.5h\_FCS})^2} \quad (9)$$

$$R_t^{dn} = \sqrt{(3 \cdot \sigma^d \cdot P_t^d)^2 + (3,5 \cdot \sigma_i^{(0.5h)\_WP} \cdot P_i^{WP})^2 + (R_t^{0.5h\_EV})^2 + (R_t^{0.5h\_FCS})^2} \quad (10)$$

$$Q_t^{up} = P_t^{gmax} + \sqrt{(3 \cdot \sigma^d \cdot P_t^d)^2 + (3,5 \cdot \sigma_i^{(4h)\_WP} \cdot P_i^{WP})^2 + (R_t^{4h\_EV})^2 + (R_t^{4h\_FCS})^2} \quad (11)^1$$

More details about reserve modeling can be found in [18], [19] and [20].

Objective function is minimization of thermal and hydro operation and management costs (12).

$$\min COST = \sum_{i=1}^{Ni} \left[ \sum_{i=1}^{Ni\_TP} (c_{t,i}^{TP}) + \sum_{i=1}^{Ni\_HP} (c_{t,i}^{HP}) \right] \quad (12)$$

### A. Power System Model

Conventional units are constrained with technical restrictions. Both thermal (TPP) and hydro power plants (HPP) models for multi service unit commitment (MSUC) optimization are usually developed as binary problems. Details about binary TPP model, and objective function as well, can be found in [21], and about HPP UC model in [22]. In order to improve computational efficiency of the MSUC model TPP and HPP in this paper they are clustered by technology type as in [23] or [24]. Even faster MSUC be modeled using relaxed linear programming UC as in [25]. Due to succinctness of the paper, TPP, HPP and WPP mathematical representation of the constraints is omitted but briefly mentioned in the text bellow.

TPP generation is constrained with following: power generation constraints (piece-wise linear cost curve), minimum up and down times, ramping constraints, reserve provision constraints and greenhouse gas emission cost function.

HPP generation is subjected by the following: water balance equation, generation power constraints, reservoir constraints, hydro turbine constraints, spillage constraint and reserve provision constraints.

WPP generation is constrained with real historical wind generation (it can be seen as max wind generation). Curtailment of WPP production is allowed when it benefits the EPS, so their actual production can be lower than historical data. Conventional power demand (CPD) is modeled as historical data (as a parameter, not as a variable).

### B. EV Model

EVs mathematical representation is one of the contributions of the paper, therefore it is discussed in this subsection in detail. EVs are modeled as variable capacity storage of aggregated electric vehicles by type (13). Energy stored in group of EV of particular type depends on energy stored in EV arriving to the electrical grid after driving ( $S^{arr}$ ), energy stored in EV leaving the grid ( $S^{leav}$ ), power used for EV charging ( $P^c$ ) and discharging ( $P^d$ ) and energy consumed by fast charging EV on fast charging stations ( $S^{add}$ ).

$$S_{t,i}^{EV} = S_{t-1,i}^{EV} + S_{t,i}^{arr\_EV} - S_{t,i}^{leav\_EV} + p_{t,i}^{c\_EV} \cdot \eta_i^{c\_EV} * \Delta t - p_{t,i}^{d\_EV} / \eta_i^{d\_EV} \cdot \Delta t + S_{t,i}^{add\_FCS} \quad (13)$$

$$p_{t,i}^{f\_EV} \geq p_i^{perf\_EV} \cdot P_i^{max\_EV} \cdot (G_i^{EV} - N_{\tau,i}^{arr\_EV}) \quad (14)$$

$$S_{t,i}^{add\_FCS} \leq \eta_i^{f\_EV} \cdot P_{(N_{(t+1)arr\_EV},i)}^{f\_EV} \cdot \Delta t \quad (15)$$

$$S_{t,i}^{add\_FCS} \leq \eta_i^{f\_EV} \cdot P_{(t-T^{thr\_EV},i)}^{f\_EV} \cdot \Delta t \quad (16)$$

Main input parameter for number of arriving and leaving vehicles as well as for the number of vehicles fast charging is electric vehicles weekly behavior derived from driving behavior of conventional vehicles in the US [26]. Used EV driving behavior, historical wind power production and conventional power

<sup>1</sup> Equations (7) and (8) apply for  $R_t^{4h\_EV}$  and  $R_t^{4h\_FCS}$  in (11), the only difference is substitution of  $\sigma^{0.5h\_EV}$  and  $\sigma^{0.5h\_FCS}$  with  $\sigma^{4h\_EV}$  and  $\sigma^{4h\_FCS}$ , respectively.

demand are displayed on Figure 1. Power for fast charging depends on number of on-road EV (14). Equations (15) and (16) are constraints for fast charging.

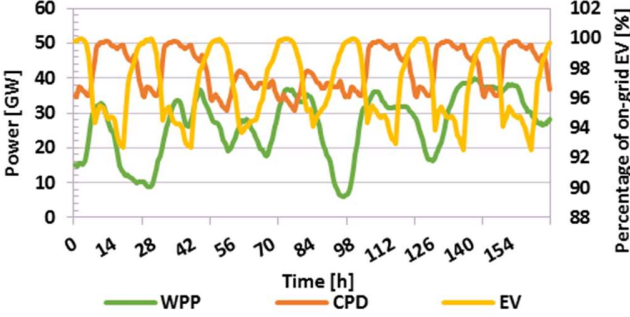

Figure 1 Input data: max wind power production, power demand and EV driving behavior

EV charging is divided as slow charging of EV (SEV; home or work charging) and fast charging at fast charging stations (FCS). Both ways of charging includes 6 modes of operation explained in Table 1 and Table 2. Most of the energy required for EV consumption is from slow home charging ( $\approx 70\%$ ). Share of fast charging in total EV charging requirements in this paper is around 30%, i.e. share of on-road EV fast charging every moment is 5%.

Table 1 Slow EV charging operation modes

SEV – Slow EV charging			
Charging\ Reserve		NR – No Reserve	YR – Yes Reserve
Uncontrolled	USC – Uncon. Slow Charging	- EV slow charge at rated power from moment they plug in until fully charged - EV do not impact reserve requirements	- EV slow charge at rated power from moment they plug in until fully charged - EV causing increase in reserve requirements
Controlled	Unidirectional	G2V – Grid to Vehicle - EV optimal slow charging (in regards to EPS) - no EV discharging - no EV reserve provision	- EV optimal slow charging (in regards to EPS) - no EV discharging - EV provide reserve
	Bidirectional	V2G – Vehicle to Grid - EV optimal slow charging & discharging (in regards to EPS) - no EV reserve provision	- EV optimal slow charging & discharging (in regards to EPS) - EV provide reserve

Mathematical representation of the EVs constraints for SEV is omitted from this paper but presented and discussed in authors' earlier papers [27], [28] and [29]. Focus of this paper is to analyze system's behavior under high penetration of wind power plants as variable renewable source and under high penetration of EV charged on FCS as a promising new flexible load on the demand side. Mathematical formulation of FCS is represented through equations (12)-(14).

Table 2 Fast charging stations operation modes

FCS – Fast Charging Stations			
Charging\ Reserve		NR – No Reserve	YR – Yes Reserve
Uncontrolled	UFC – Uncon. Fast Charging	- EV fast charge directly from the grid - FCS providing charging spot only - no FCS impact on reserve requirements	- EV fast charge directly from the grid - FCS providing charging spot only - FCS causing increase in reserve requirements
Controlled	Unidirectional	G2S – Grid to Station - EV fast charge through EES integrated in FCS - FCS/ESS optimal charging (from the grid) - no FCS/ESS discharging to the grid - no FCS reserve provision	- EV fast charge through EES integrated in FCS - FCS/ESS optimal charging (from the grid) - no FCS/ESS discharging to the grid - FCS provide reserve
	Bidirectional	S2G – Station to Grid - EV fast charge through EES integrated in FCS - FCS/ESS optimal charging & discharging - no FCS reserve provision	- EV fast charge through EES integrated in FCS - FCS/ESS optimal charging & discharging - FCS provide reserve

The availability of EV for fast charging is modelled in equation (12). Fast charging power is added to main EV equation (13) through equation (14) and (15). Equations (16) – (17) are representing UFC mode, (18) – (23) are representing G2S mode and (24) – (29) S2G mode.

$$p_{t,i}^{f,EV} \geq p_i^{perf,EV} \cdot p_i^{fmax,EV} \cdot (G_i^{EV} - N_{t,i}^{g,EV}) \quad (12)$$

$$s_{t,i}^{add,FCS} \leq \eta_i^{f,EV} \cdot p_{(Nt+T^{dur,EV})_i}^{f,EV} \cdot \Delta t \quad (13)$$

$$s_{t,i}^{add,FCS} \leq \eta_i^{f,EV} \cdot p_{(t-T^{dur,EV})_i}^{f,EV} \cdot \Delta t \quad (14)$$

$$p_{t,i}^{c,FCS} = p_{t,i}^{f,FCS} \quad (16)$$

$$p_{t,i}^{d,FCS} = 0 \quad (17)$$

$$P_i^{min,FCS} \cdot G_i^{FCS} \leq p_{t,i}^{c,FCS} \leq P_i^{max,FCS} \cdot G_i^{FCS} \quad (18)$$

$$p_{t,i}^{d,FCS} = 0 \quad (19)$$

$$r_{t,i}^{up,FCS} \leq P_i^{c,FCS} - P_i^{min,FCS} \cdot x_{t,i}^{c,FCS} \quad (20)$$

$$r_{t,i}^{dn,FCS} \leq P_i^{max,FCS} \cdot G_i^{FCS} - P_i^{c,FCS} \quad (21)$$

$$f_{t,i}^{up,FCS} \leq P_i^{c,FCS} - r_{t,i}^{up,FCS} - P_i^{min,FCS} \cdot x_{t,i}^{c,FCS} \quad (22)$$

$$f_{t,i}^{dn,FCS} \leq P_i^{max,FCS} \cdot G_i^{FCS} - P_i^{c,FCS} - r_{t,i}^{dn,FCS} \quad (23)$$

$$P_i^{min,FCS} \cdot x_{t,i}^{c,FCS} \leq p_{t,i}^{c,FCS} \leq P_i^{max,FCS} \cdot x_{t,i}^{c,FCS} \quad (24)$$

$$P_i^{min,FCS} \cdot (G_i^{FCS} - x_{t,i}^{c,FCS}) \leq p_{t,i}^{d,FCS} \leq P_i^{max,FCS} \cdot (G_i^{FCS} - x_{t,i}^{c,FCS}) \quad (25)$$

$$r_{t,i}^{up,FCS} \leq P_i^{max,FCS} \cdot (G_i^{FCS} - x_{t,i}^{c,FCS}) - P_i^{d,FCS} + p_{t,i}^{c,FCS} - P_i^{min,FCS} \cdot x_{t,i}^{c,FCS} \quad (26)$$

$$r_{t,i}^{dn,FCS} \leq P_i^{d,FCS} - P_i^{min,FCS} \cdot (G_i^{FCS} - x_{t,i}^{c,FCS}) + P_i^{max,FCS} \cdot x_{t,i}^{c,FCS} - P_i^{c,FCS} \quad (27)$$

$$f_{t,i}^{up\_FCS} \leq P_i^{max\_FCS} \cdot (G_i^{FCS} - x_{t,i}^{c\_FCS}) \quad (28)$$

$$-P_i^{d\_FCS} + p_{t,i}^{c\_FCS} - P_i^{min\_FCS} \cdot x_{t,i}^{c\_FCS} - r_{t,i}^{up\_FCS} \quad (29)$$

$$f_{t,i}^{dn\_FCS} \leq P_i^{d\_FCS} - P_i^{min\_FCS} \cdot (N_{t,i}^{g\_FCS} - x_{t,i}^{c\_FCS})$$

$$+ P_i^{max\_FCS} \cdot x_{t,i}^{c\_FCS} - p_{t,i}^{c\_FCS} - r_{t,i}^{dn\_FCS}$$

### III. CASE STUDIES

Using inflexible thermal system with high wind penetration, impact of different fast charging stations (FCS) operation modes on unit commitment and rotating reserve provision<sup>2</sup> is analyzed in detail. Shares of conventional units used in following simulations are: 35% nuclear, 45% coal, 15% combined cycle gas turbines (CCGT) and 5% open cycle gas turbines (OCGT). Listed shares are observed in regards to total net demand required for feasible operation (CPD – WPP + rotation reserve requirements = 50 GW). Share of WPP is 60% of total required generation capacity (CPD + rotation reserve requirements = 60 GW). When talking about EV integration, percentage corresponds to the share of EV in today's total vehicle's fleet in UK, 50% is used in this paper. One Slow EV charging operation mode is used for observation, controlled slow charging without discharging but with reserve provision G2V-YR (Figure 3). This slow charging mode seems to be most probable in slow home charging. Legend for both figures is displayed on Figure 2. Figure 3 is showing one week unit commitment (first column), provision of secondary up reserve (second column) and secondary down reserve (third column) for the observed inflexible power system. Seven cases are listed as rows of graphs, case without EV and EV fast charging through six FCS operation modes defined in Table 2. Every graph inside figures includes power in GW on x-axis and time in hours on y-axis. Unit commitment graphs are divided into two parts, first one are colored areas representing unit commitment (generated energy) and second are colored lines representing total demand (black), demand without EV (light blue), EV fast charging (blue), EV slow charging (green) and FCS charging (pink). Red area above demand line is curtailed wind energy, while purple area just under demand line is energy discharged from FCS energy storage. Reserve graphs have the same division, colored areas represent reserved energy for contingency while colored lines represent total reserve requirements (black) and reserve requirements without EV's impact (light blue).

Once again, Table 3 and Figure 3 are presenting FCS operation mode impacts on unit commitment and reserve provision in combination with slow charging mode – G2V-YR.

When observing NO-EV case (reference case) on Figure 3 (USC-YR SEV operation mode) it can be noticed that both Nuclear Power Plants (NPP) and Coal Power Plants (CPP) are working at fixed power through one week period. The only difference is that NPP generate at full power while CPP power provision is lower than rated due to reserve provision requirements (second column). Most of the reserve up and almost all reserve down is provided by CPP. Wind power plants are scheduled only in peak periods, because reserve requirements are not allowing CPP to lower their generation in order to utilize more wind energy EV's involvement in power system in observed SEV mode brings more than 40 % decrease in TSC in all FCS operation modes, more than 70% TSE decrease in all FCS operation modes and more than 94% decrease in WPC even in UFC-NR operation mode. Such great flexibility improvements are due to two main reasons: controlled (flexible) charging which allows energy arbitrage and reserve provision which eliminates reserve constraints on coal and gas power plants.

Even though we add additional flexibility requirements through UFC-NR and especially UFC-YR operation mode, all flexibility metrics are significantly reduced. It actually means that slow charging is providing more flexibility than it is required for coverage of fast charging's inflexibility. Most of the reserve up is provided by SEV as well as complete reserve down. Coal and gas units are providing up reserve in periods when they are also used for power generation (low wind periods).

In G2S-NR mode metrics are further decreased, Table 3. FCS and SEV are both operating as energy arbitrage units thus reducing WPC to almost zero value ( $\approx 0.16\%$  of WPC from NO-EV case). By permitting FCS reserve capabilities, FCS are promoted to main reserve providers in both up and down reserve provision. Slow charging of EVs is less stressed, and it can be better utilized for energy arbitrage. For example, SEV charging has increased during weekends high periods when wind is high. Wind power curtailment is equal to zero.

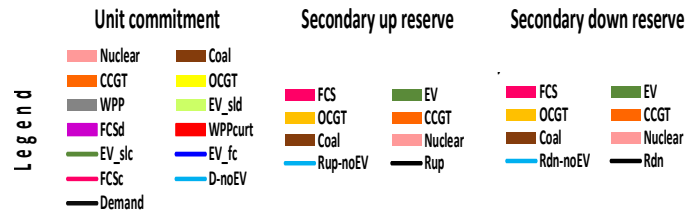

Figure 2 Legend for Figure 3

Table 3 Flexibility parameters – SEV operation mode: G2V-YR

Flexibility metrics	NO-FCS	UFC-NR	UFC-YR	G2S-NR	G2S-YR	S2G-NR	S2G-YR
TSC [10 <sup>6</sup> €]	76,18	43,45	44,10	41,29	40,77	40,67	40,61
TSE [10 <sup>9</sup> kg CO <sub>2</sub> ]	2,40	0,73	0,75	0,62	0,62	0,62	0,61
WPC [GWh]	2971,06	158,41	185,24	4,75	0,00	0,00	0,00

<sup>2</sup> Due to succinctness of the paper only secondary reserve will be discussed, but the same conclusions can be made for the primary reserve provision.

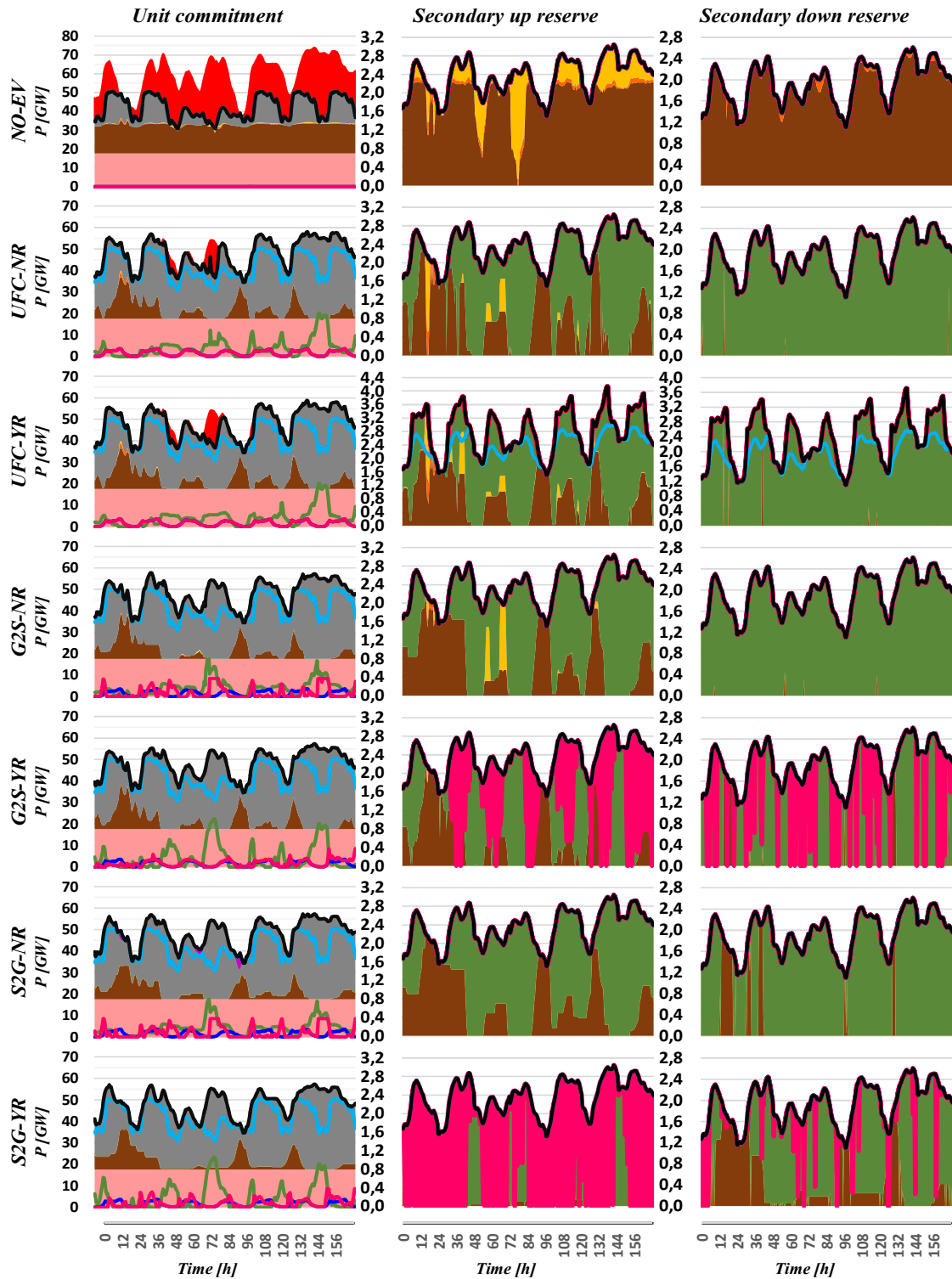

Figure 3 Fast charging impact on power system operation – SEV operation mode: G2V-YR

Usage of gas turbines is completely unnecessary when FCS discharging is included. Again, as in G2S-NR mode, SEV and FCS are providing combined energy arbitrage service. Power generated by wind turbines is completely utilized and there is no wind curtailment. S2G-YR mode provides most of up reserve.

while down reserve is provided by SEV, FCS and coal power plants.

#### IV. CONCLUSION

Detailed model for EV's impact on power system operation has been developed using mixed integer linear programming in Fico Xpress programming environment. Electric vehicle's charging has been observed as slow charging at home or work and as fast charging at fast charging stations. Both slow and fast charging are further classified into six charging modes depending on their ability to control their charging or reserve provision. One slow charging mode with strong implementation likelihood is used in this paper representing flexible (G2V-YR) mode. In G2V-YR mode slow charging is flexible enough to couple with uncontrollable fast charging stations and wind power plants. Also, in both SEV operation modes, flexibility gained by allowed reserve provision is higher than flexibility gained by allowed discharging.

#### ACKNOWLEDGMENT

This work has been supported in part by the Croatian Science Foundation under the project IP-09-2014-3517 and FENISG-Flexible Energy Nodes in Low Carbon Smart Grid funded by Croatian Science Foundation under project grant No. 7766.

#### REFERENCES

- [1] B. C. Ummels, M. Gibescu, E. Pelgrum, W. L. Kling, and A. J. Brand, "Impacts of Wind Power on Thermal Generation Unit Commitment and Dispatch," *IEEE Trans. Energy Convers.*, vol. 22, Mar. 2007.
- [2] R. Gross, T. Green, M. Leach, J. Skea, P. Heptonstall, and D. Anderson, "The Costs and Impacts of Intermittency.," 2006.
- [3] D. Papadaskalopoulos, G. Strbac, P. Mancarella, M. Aunedi, and V. Stanojevic, "Decentralized Participation of Flexible Demand in Electricity Markets—Part II: Application With Electric Vehicles and Heat Pump Systems," *IEEE Trans. Power Syst.*, vol. 28, Nov. 2013.
- [4] H. Pandzic, Y. Wang, T. Qiu, Y. Dvorkin, and D. S. Kirschen, "Near-Optimal Method for Siting and Sizing of Distributed Storage in a Transmission Network," *IEEE Trans. Power Syst.*, vol. PP, 2014.
- [5] K. Dietrich, J. M. Latorre, L. Olmos, and A. Ramos, "Demand Response in an Isolated System With High Wind Integration," *IEEE Trans. Power Syst.*, vol. 27, no. 1, pp. 20–29, Feb. 2012.
- [6] N. Holjevac, T. Capuder, and I. Kuzle, "Adaptive control for evaluation of flexibility benefits in microgrid systems," *Energy*, May 2015.
- [7] P. Fan, B. Sainbayar, and S. Ren, "Operation Analysis of Fast Charging Stations With Energy Demand Control of Electric Vehicles," *IEEE Trans. Smart Grid*, vol. PP, no. 99, pp. 1–8, 2015.
- [8] K. Thirugnanam, T. P. E. R. Joy, M. Singh, and P. Kumar, "Modeling and control of contactless based smart charging station in V2G scenario," *IEEE Trans. Smart Grid*, vol. 5, no. 1, pp. 337–348, 2014.
- [9] W. Yao, J. Zhao, F. Wen, Z. Dong, and S. Member, "A Multi-Objective Collaborative Planning Strategy for Integrated Power Distribution and Electric Vehicle Charging Systems," *IEEE Trans. Power Syst.*, vol. 29, no. 4, pp. 1811–1821, 2014.
- [10] R.-C. Leou, C.-L. Su, and J.-H. Teng, "Modelling and verifying the load behaviour of electric vehicle charging stations based on field measurements," *IET Gener. Transm. Distrib.*, vol. 9, 2015.
- [11] G. Wang, Z. Xu, F. Wen, and K. P. Wong, "Traffic-constrained multiobjective planning of electric-vehicle charging stations," *IEEE Trans. Power Deliv.*, vol. 28, no. 4, pp. 2363–2372, 2013.
- [12] A. Y. S. Lam, Y.-W. Leung, and X. Chu, "Electric Vehicle Charging Station Placement: Formulation, Complexity, and Solutions," *IEEE Trans. Smart Grid*, vol. 5, no. 6, pp. 2846–2856, 2014.
- [13] S. Pazouki, A. Mohsenzadeh, and S. Member, "Simultaneous Planning of PEV Charging Stations and DGs Considering Financial, Technical, and Environmental Effects Planification simultanée des stations de recharge de PEV et des DG en considérant les critères," vol. 38, no. 3, pp. 238–245, 2015.
- [14] F. He, Y. Yin, and J. Zhou, "Deploying public charging stations for electric vehicles on urban road networks," *Transp. Res. Part C Emerg. Technol.*, vol. 60, pp. 227–240, Nov. 2015.
- [15] S. Guo and H. Zhao, "Optimal site selection of electric vehicle charging station by using fuzzy TOPSIS based on sustainability perspective," *Appl. Energy*, vol. 158, pp. 390–402, Nov. 2015.
- [16] W. Lee, L. Xiang, S. Member, R. Schober, V. W. S. Wong, and S. Member, "Electric Vehicles Charging Stations With Renewable Power Generators: A Game Theoretical Analysis," *IEEE Trans. Smart Grid*, vol. 6, no. 2, pp. 608–617, 2015.
- [17] M. R. Sarker, H. Pandzic, and M. a. Ortega-Vazquez, "Optimal Operation and Services Scheduling for an Electric Vehicle Battery Swapping Station," *IEEE Trans. Power Syst.*, vol. 30, 2015.
- [18] Y. Rebours and D. S. Kirschen, "A Survey of Definitions and Specifications of Reserve Services," 2005.
- [19] M. Aunedi, "Value of Flexible Demand-Side Technologies in Future Low-Carbon Systems," Imperial College London, 2013.
- [20] V. Silva, "Value of flexibility in systems with large wind penetration," University of London, 2010.
- [21] M. Carrion and J. M. Arroyo, "A Computationally Efficient Mixed-Integer Linear Formulation for the Thermal Unit Commitment Problem," *IEEE Trans. Power Syst.*, vol. 21, Aug. 2006.
- [22] E. G. Kardakos, C. K. Simoglou, and A. G. Bakirtzis, "Hydrothermal producer offering strategy in a transmission-constrained electricity market: An MPEC approach," *IEEE PES Innov. Smart Grid Technol. Conf. Eur.*, vol. 2015–Janua, no. January, pp. 1–6, 2015.
- [23] M. Aunedi, "Value of Flexible Demand-Side Technologies in Future Low-Carbon Systems," Imperial College London, 2013.
- [24] D. Pudjianto, M. Aunedi, P. Djapic, and G. Strbac, "Whole-Systems Assessment of the Value of Energy Storage in Low-Carbon Electricity Systems," *IEEE Trans. Smart Grid*, vol. 5, Mar. 2014.
- [25] L. Zhang, S. Member, and T. Capuder, "Unified Unit Commitment Formulation and Fast Multi-Service LP Model for Flexibility Evaluation in Sustainable Power Systems," pp. 1–14, 2015.
- [26] R. Van Haaren, "Assessment of Electric Cars' Range Requirements and Usage Patterns based on Driving Behavior recorded in the National Household Travel Survey of 2009," 2011.
- [27] I. Pavić, T. Capuder, N. Holjevac, and I. Kuzle, "Role and impact of coordinated EV charging on flexibility in low carbon power systems," in *2014 IEEE International Electric Vehicle Conference (IEVC)*, 2014, pp. 1–8.
- [28] I. Pavić, T. Capuder, and I. Kuzle, "Value of flexible electric vehicles in providing spinning reserve services," *Appl. Energy*, vol. 157, pp. 60–74, Nov. 2015.
- [29] I. Pavić, T. Capuder, and I. Kuzle, "Defining the Role of Traditional and Low Carbon Technologies in Providing Flexibility for Future Power Systems Operation," in *Digital Proceedings of the 10th Conference on Sustainable Development of Energy, Water and Environment Systems – SDEWES*, 2015.





## **Publication 14**

I. Pavić, T. Capuder, and H. Pandžić, “Profit margin of electric vehicle battery aggregator,” in *2018 IEEE International Energy Conference (ENERGYCON)*, IEEE, Jun. 2018, pp. 1–6, ISBN: 978-1-5386-3669-5. DOI: 10.1109/ENERGYCON.2018.8398790

# Profit Margin of Electric Vehicle Battery Aggregator

Ivan Pavić, Tomislav Capuder, Hrvoje Pandžić

University of Zagreb, Faculty of Electrical Engineering and Computing

Unska 3, 10000 Zagreb, Croatia

[ivan.pavic@fer.hr](mailto:ivan.pavic@fer.hr), [tomislav.capuder@fer.hr](mailto:tomislav.capuder@fer.hr), [hrvoje.pandzic@fer.hr](mailto:hrvoje.pandzic@fer.hr)

**Abstract**—In the light of power system decarbonization, electric vehicles are becoming an important tool to bridge the gap between traditional and low-carbon power systems. If aggregated, electric vehicle's fleet can provide flexibility to system operator. Recent literature defines aggregators as electric vehicle charger aggregators which collides with the conventional way of observing electric vehicles, as stationary chargers with connected loads/vehicles. This paper observes them as mobile batteries, not chargers. Therefore, new concept of electric vehicle battery aggregator has been defined which exploits their mobility. Battery aggregator has more information about vehicle's behavior and can maximize their flexibility provision regardless when and where they charge. New concept brings benefits to all system participants from electric vehicle owners, aggregators, and system operators to society altogether.

**Index Terms**—Electric Vehicles, Electric Vehicle Battery Aggregator, Charging Stations, Flexibility, Batteries

## I. INTRODUCTION

Power system decarbonization enforces new operation paradigm to power system operators. Until recently, conventional generators (CG) were used to provide bulk energy and ancillary services to suppliers and system operators, respectively. Over the last two decades, share of electricity generated from variable and renewable energy sources (RES) increased drastically, while more expensive CGs gets decommissioned. Higher share of inflexible RES and decreasing number of flexible CGs leads to insufficient flexibility for ancillary services. System operators must have enough flexibility to maintain continuous operation and supply. Since the generation side cannot provide enough flexibility, system operators turned to demand side where flexibility can be extracted through demand response programs, energy storage, electric vehicles (EV) etc. In flexibility terms, EVs can be seen somewhat in between demand response and energy storage as they can change their consumption profile but also provide energy arbitrage with their batteries. EV's batteries are small in capacity and they can participate in wholesale markets jointly through new entity named electric vehicle's aggregator (EVA).

This paper will define and classify EVs interaction with power system and propose a new concept of EVA where the objective is maximization of flexibility from EVs.

## A. Literature Review

This subsection is going to review recent literature related to EVA in power system research community. EVA in [1] aggregates EVs to participate in electricity and regulation markets. EVA observes only night residential charging, i.e. EVA doesn't observe specific EV's behavior throughout day instead EVA aggregates home chargers of EV users. Input parameters required from EV owners are arrival battery state-of-charge (SOC), arrival and departure times. Paper [2] explores a solution where the EVA directly controls the charging of EVs plugged-in to slow charging points (residential area) and bids for balancing reserve. Input data for EVA are targeted and initial SOC, expected and departure times. For each EV arriving to the charger availability period and charging requirement are defined. If an EV comes to charging point few times a day each new arriving is considered as a new EV. EVA in [3] participate in European style electricity and reserve markets through novel business rationale: bid maximum amount of negative reserve by EVs and use the intraday market as a backup source for charging energy. Each EV upon connection to charger submits: arrival and forecasted departure times, and SOC. EVA observes only time when EV connects to charger which effectively means it aggregates specific chargers activated only when EV plugs in.

Comprehensive stochastic optimization model of EVA in day-ahead energy and ancillary services markets has been proposed in [4]. The SOC at arrival/departure times for individual EVs are forecasted and based on EVs driving/parking profiles. All observed EVAs are positioned in the same bus connected through night hours. Such definition reveals that EVA are aggregators of EV home chargers. Paper [5] propose a model of EVA as price maker and take into account the impact of the aggregator's bids on prices using a bilevel formulation. EVs should communicate their planned trips to the EVA. The individual plans are aggregated and large fleet is defined as time-varying battery. Authors in [6] reported a bidding strategy on electricity and regulation markets where EVA tends to maximize its profit while compensating EVs for battery degradation. Each EV should inform the aggregator their availability (connection to charger). Focus of paper [7] is on the scheduling problem of EV charging in a smart charging station which operates under the mechanism of vehicle-to-vehicle (V2V). EV at charging station set the charging task, however some EVs can function as energy storage and transfer their stored energy to other EVs

---

This work has been co-funded by Climate change research program for period 2015-2016 supported by Government of Croatia project SUCCESS-Sustainable Concept for Integration of Distributed Energy Storage Systems and by the Croatian Science Foundation under the project Electric Vehicles Battery Swapping Station (EVBASS) - IP-2014-09-3517.

with more urgent deadlines – V2V. Authors in [8] use ADMM to decompose the EVA optimization problem. EVs and EVA solve their individual problems and message the incentive/solution/information signal between them. The input parameter is their deterministic driving/parking profile which implies that they are observing longer optimization time frames not just one parking period but they do not explain how would it be implemented in practice.

Authors in [9] define the EVA as physical entity that connects to the distribution network through a main transformer. EVA is responsible for EVs charging, while maintaining the capacity constraints of its main transformer. Since the EVA is physical entity it aggregates chargers connected to its grid. Authors in [10] designed demand response strategy of smart household with incorporated EVs with vehicle-to-home and vehicle-to-grid capabilities. Household energy management’s objective function is to minimize total household energy cost using EVs as source of flexibility. EVA in [11] is charging station’s controller on university campus parking lots. Proposed charging strategy tends to minimize peak load curve using controlled EVs flexible charging and it is proven by results. Input parameters are current SOC, and the expected departure SOC and time. Paper [12] observes control strategies and communications requirements for system’s load frequency control using EVA (defined as controllers of parking lots). The results show that frequency deviations can be decreased using EVs. Input parameters required from EV owners are battery capacity, initial and real-time SOC, as well as charging mode. Paper [13] proposes optimization framework for battery swapping station (BSS) which acts as an intermediary between power system and EV users. BSS can interact with system in bidirectional flexible manner but can also transfer energy between batteries within its battery stack if high prices occur.

Papers [14] and [15] tackle the problem of EV aggregation from the system point of view where effects of both slow and fast charging on power system has been investigated. It could be noticed that EV integration can improve power system operation if smart charging is applied or if storage is implemented into fast charging stations. On the other hand, passive charging can lower power system efficiency and increase system costs.

Based on literature review, it can be noticed that EV integration into power system is an active, prominent, and ongoing research area. Research community have high expectations for utilization of EVs to provide flexibility to power system. Impact of EVAs has been well investigated in theory, but none of the research papers tackled the issue of EVA’s practical implementation.

### B. The new concept – background

EVA has generally been defined as intermediary between EVs and market/system operator where EVA buys/sells energy/ancillary services on behalf of EVs. However, in reality, it aggregates EV chargers with connected EVs. EV can use/provide energy/ancillary services to the grid only when EV is connected to charger operated by its aggregator. EVs usually provide four input parameters to EVA: metered arrival time & SOC and preferred departure time & SOC. Based on

predictions or historic profiles EVA can build demand profiles for its fleet to use them at wholesale markets. EVA defined in this manner resulted from conventional way of addressing the EVs: as any other electric load stationary connected to specific geographic location and specific socket. In fact, EVA is an electric vehicle charger aggregator and it can use only the flexibility of EV batteries within defined availability period on defined locations. EVA do not have information about EV battery SOC prior and after the connection. We argue that EVs should not be observed as conventional loads but as mobile batteries. EVA should not aggregate specific EV chargers physically located at households, parking lots or charging stations but the EVs with their batteries by themselves. The new concept of EVA is therefore named as electric vehicle battery aggregator or EVBA.

EVBA could continuously throughout day track the EV information (SOC, planned trips) as part of future internet of things concept and charge/discharge EVs on whatever charger they connect to. Charger owners/operators should allow all EVs to charge without restrictions but for additional charging fee (charging infrastructure roaming). They should be understood as infrastructure operators similar to transmission/distribution system operators and charging fee as transmission/distribution fee (tariff).

## II. DEFINITIONS AND CLASIFICATIONS

To define and elaborate EVBA concept next paragraphs will provide definitions and classifications to different EV charging infrastructure, modes, services, and benefits.

### A. EV charging infrastructure types

EVs, in contrary to their internally combusted counterparts, possess a wide range of possible charging methods. Interdependency of EV’s charging and driving/parking processes can be described through three main charging infrastructure types (illustrated on Figure 1):

- Drive & Charge lanes (or on-road charging): the primary task is to drive an EV, but at the same time owner can recharge it through infrastructure installed at roadways. D&C is possible as conductive – CCL (galvanic connection) or inductive – ICL (wireless connection) energy transfer between EV and charging lane.
- Stop & Charge stations (or stop-by charging): driving with brief stops for charging through infrastructure installed next to roadways. S&C can be carried out through battery swapping stations – BSS (EVs swap empty for full battery) and Fast Charging Stations – FCS (short charging times, high charging power).
- Park & Charge lots (or parked charging): the primary task is to park an EV, but at the same time owner can recharge it through infrastructure installed at parking lots. P&C lots with high EV interchange frequency include medium chargers (medium charging times and power), while low-frequent lots include slow chargers (long charging times, low charging power).

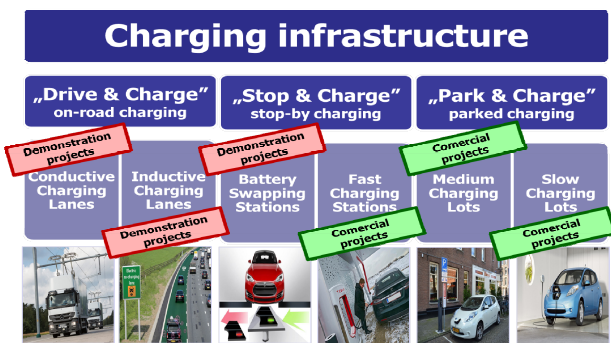

Figure 1. EV's charging infrastructure types

### B. EV charging modes in regards to EVSE flexibility

Each EV requires energy for motion, however EVs usually do not spend all energy for their trips and have spare energy or power capacity which can be used to sell flexibility services to system operator. Five main modes of power interchange between EV's and power grid can be identified:

- Uncontrolled or fixed power charging:
  - EVs charge at maximum power since plugged-in until fully charged (D&C, FCS, and P&C);
  - Batteries charge at maximum power since stocked-in battery stock until fully charged (BSS);
- Unidirectional controlled grid charging:
  - Grid-to-Vehicle (G2V): EVs charge according to aggregator's instructions (D&C, P&C);
  - Grid-to-Station (G2S): FCS charge controllable through energy storage as a buffer, but each of EVs within the station is charged uncontrollable (FCS);
  - Grid-to-Battery (G2B): Batteries charge according to BSS operator's instructions (BSS);
- Bidirectional controlled grid charging/discharging:
  - Vehicle-to-Grid (V2G): EVs charge or discharge according to aggregator's instructions (D&C, P&C);
  - Station-to-Grid (S2G): FCS charge/discharge controllable through energy storage, but each of EVs within the station is charged uncontrollable (FCS);
  - Battery-to-grid (B2G): batteries charge/discharge according to BSS operator's instructions (BSS);
- Controlled without grid charging:
  - Home-to-Vehicle/Vehicle-to-home (H2V/V2H): EVs charge/discharge using energy generated or stored in household (Slow Charging Lots);

- Vehicle-to-Vehicle (V2V): EVs function as energy storage and transfer their stored energy to other EVs with more urgent deadlines (D&C, P&C);
  - Battery-to-Battery (B2B): Batteries function as energy storage and transfer their stored energy to other batteries with higher SOC (BSS).
- Controlled charging with additional services:
    - Vehicle-for-Grid (V4G): EV's charging/discharging flexibility is used for grid-specific ancillary services such as voltage control (D&C, P&C);

### C. EV's flexibility services

EVs can provide flexibility services utilizing controlled charging modes listed in Subsection II. B. In this paper, flexibility services are defined as the use of EV's controllable charging/discharging ability to change power rates at grid connection point. In general, these services are all actions beside basic charging (whose purpose is to increase the SOC to and to ensure energy for mobility) and they can be:

- Up regulation achieved through:
  - If charging – charging power decrease,
  - If discharging – discharging power increase,
  - If idle – start discharging,
- Down regulation achieved through:
  - If charging – charging power increase,
  - If discharging – discharging power decrease.
  - If idle – start charging.

### D. EVA types

EVA can act on different markets with different objective functions. In general, EVA can act as:

- Conventional supplier of EV chargers: Chargers are regarded as any other load (fixed charging) and EVA buys energy for them in energy-only markets;
- Flexible supplier of EV chargers: EVA supplies EVs (energy-only market) and use charger's flexibility (controlled charging) to balance its own stochasticity;
- EV charger aggregator – BRP balancing: EVA supplies EVs (energy-only market) and use charger's flexibility (controlled charging) to provide balancing services to other participants (balance responsible parties – BRP);
- EV charger aggregator – System balancing: EVA supplies EVs (energy-only market) and use charger's flexibility (controlled charging) to provide balancing ancillary services (regulation and reserve markets);
- EV charger aggregator – Grid services: EVA use charger's flexibility to provide grid-specific ancillary services (voltage/reactive power control, black start...).

EVBA concept can efficiently incorporate all above-mentioned types depending on market design and regulation.

### III. NEW CONCEPT

Charging at any infrastructure type described in Subsection II. A. depends on the same EV's SOC. However, based on current EVA definition, different aggregators (FCS/BSS operators or slow charger aggregators) act independently one from another and act as competitors. The idea is to create EVBA business model with the insight into charging at all infrastructure types and by doing so extracting maximum benefits from EV battery's flexibility.

#### A. The core of EVBA concept

Benefits of charging an EV at slow/medium charging lots (SCL or MCL) versus FCS are multiple: lower power rates – lower battery degradation, off peak charging – lower charging energy, charging at one's backyard – no need for travel to charge, long charging times – high possibility to provide flexibility services... For this reason, slow/medium charging should be used for bulk energy charging, while other infrastructure types are supplementary when additional motion energy is required. SCL/MCL are usually part of other consumer facilities and they are controlled within their smart environment (smart households, buildings, parking lots etc.). It's not quite clear how an EVA can aggregate chargers (sockets) within other's property. That's why each charger should have its own independent metering so energy for/from EV can be exactly defined. When using charger metering several problems arise. How to execute billing if EV charges on charger that is not his property since supplier relates to chargers not EVs? How to include charging on different charging infrastructure in EVA's future demand forecasts? How to pay for or forecast an EV's flexibility services? Our solution to these questions is to implement metering on EV's batteries and to aggregate batteries itself, not their chargers, which is the core of EVBA concept.

In such design, SOC of batteries is tracked down by EVBA on continuous basis and EVs long-term flexibility could be utilized. For example, consider a case of a single EV illustrated on Figure 2 and Figure 3. Figures are representing EV's driving/parking/charging profile through three adjacent days. Areas represent EV's availability to charge, while red lines represent EV's SOC for the case of uncontrollable charging (it doesn't provide insight in EV's SOC profile when used for flexibly services). Exemplary EV uses three charging infrastructure types: home-charger (where it parks every night), a work-charger (where it parks during workhours), and a FCS (on road to its favorite restaurant where it recharges every couple of days). Home-charger is EV owner's property, work-charger is EV owner company's property and FCS is of private recharging company. Under conventional EVA concept, home and work chargers would utilize EV's flexibility just during EV's parking hours on that specific charger without knowledge of charging and discharging outside that specific parking period. Different charging periods are illustrated with different colors on Figure 2 and each of them is independent from each another. EV's cannot charge bulk of their power when energy prices are low (for example at weekends) or provide extra flexibility when flexibility prices are high since they do not record the history and do not *predict* the future. The also do not have

information about SOC behavior due to driving and charging on FCS. In EVBA concept, EVs would optimally charge on different chargers while observing longer period. EVBA can track SOC information in all green areas of Figure 3. Since, EVBA have continuous information about battery's behavior stochasticity will decrease radically while forecasting and scheduling becomes far more efficient.

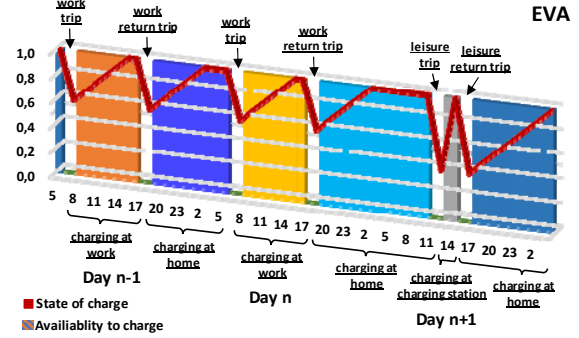

Figure 2. EV's driving/parking/charging behavior under conventional EVA

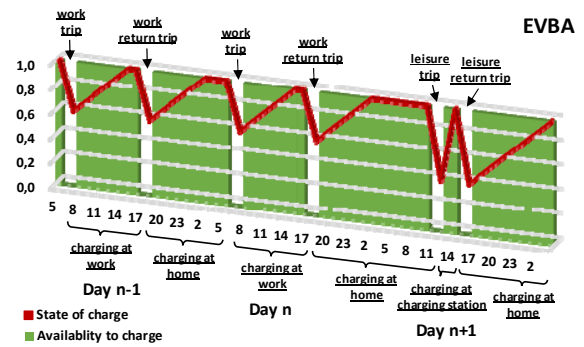

Figure 3. EV's driving/parking/charging behavior under EVBA

#### B. Additional business opportunities of EVBA concept

Nowadays, many companies worldwide offers EV charging services through their own or through roaming on others' charging infrastructure. There is also many ICT platforms offering mapping and information about charging infrastructure as well as optimal EV routing to closest and cheapest chargers. Such activities require detail information about EVs planned trips and battery characteristics. Since EVBA already handle all those data for its clients, a service of optimal EV routing is easily implemented to its algorithms.

Even though charging at FCS is more expensive and more degrading, it is sometimes required as supplementary to SCL/MCL due to three reasons:

- Unexpected trips before EV has been charged as planned and scheduled;
- Insufficient charging times at SCL/MCL (business EVs, e.g. taxis), requires additional energy to finish activities;
- Insufficient driving range, EV's battery is depleted before the end of the trip (e.g. intercity trips).

Investments in FCS are slow and usually executed by companies whose primary goal is not to earn through EV charging but to attract customers for their core business (commercial sector, energy companies, EV manufactures, city authorities...). Since EVBA have EV's detail information, they would be ideal company to site, size and invest in FCS at most frequent routes. It can provide competitive edge to EVBA and increase the number of its clients.

The same idea applies for charging lanes and BSS. The former is still in its early stage of development, while the latter have conceptual issues. The BSS advantages are short swapping times and lower battery degradation rate. In BSS concept all the batteries are BSS property. BSS needs to have significant number of batteries to even start its operation which makes capital-intensive to invest in BSS. Another issue is that BSS doesn't allow charging outside BSS facility due to degradation reasons which is not appealing neither to EVAs nor to EV users. If an EV wants to recharge its battery by a dozen percent, the swapping process is the same as for the empty battery. Insufficient battery standardization between various battery and car manufactures is a big issue as well.

Using EVs to provide flexibility services often collide with the problem of battery degradation. Capital cost of buying an EV is high where one of the most expensive parts is battery. EV's users are unwilling to lend their batteries to aggregator for flexibility services even if the charging would be cheaper because, eventually, they would end up with destroyed battery. Since EVB concept base itself on strong control of EV's batteries, the opposite interaction of EV's users and EVBA would be extremely beneficial: the EVBA should participate in EV owner's investment costs by buying the battery and effectively lending it to EV owner for mobility. The benefits of such model would be multiple:

- EV owner's investment costs are significantly decreased and EVs become accessible to wider range of users;
- EV owners do not have to coupe up with battery charging and degradation (EVBA takes over);
- EVBA acquires batteries for the whole fleet which leads to lower battery costs due to volume discounts;
- EVBA receives continuous information about battery conditions and could easily perform on-line monitoring and diagnostics effectively becoming ideal battery maintenance company and prolonging battery lifetime;
- EVBA can offer battery swapping due to degradation and swap EV's battery when battery's maximal capacity falls under certain value;
- After battery capacity drops under values usable for mobility in EVs, EVBA can second-use them as stationary storage (especially within its own FCS to lower the peak demand and costs);
- Since, the main BSS obstacles are solved (ownership and battery degradation), EVBA could invest in BSS at frequent FCS locations and increase its revenues.

#### IV. CONCLUSION

New concept of EV aggregator, named electric vehicle battery aggregator – EVBA has been proposed and demonstrated. EVBA aggregates EV batteries, hence long-term EV flexibility can be most efficiently utilized. Continuous information exchange takes place between EVs and EVBAs. Efficient EVBA integration and design can bring benefits to different system participants. Existing EV owners can experience cost savings, new EV users can be stimulated, while their EVBAs can exploit new business opportunities. Grid operators can increase grid efficiency, while system operators can carry out more efficient system balancing. In general, society benefits are twofold: decarbonization of power (increased feasible RES penetration levels) and transportation system (increased attractiveness of electrification process).

Future research will focus on EVs and EVBAs modeling in stochastic electricity and ancillary services market environment where the benefits of EVBA versus conventional EVA will be demonstrated.

#### REFERENCES

- [1] S. I. Vagropoulos and A. G. Bakirtzis, "Optimal Bidding Strategy for Electric Vehicle Aggregators in Electricity Markets," *IEEE Trans. Power Syst.*, vol. 28, no. 4, pp. 4031–4041, Nov. 2013.
- [2] R. J. Bessa and M. A. Matos, "Optimization Models for EV Aggregator Participation in a Manual Reserve Market," *IEEE Trans. Power Syst.*, vol. 28, no. 3, pp. 3085–3095, Aug. 2013.
- [3] C. Goebel and H.-A. Jacobsen, "Aggregator-Controlled EV Charging in Pay-as-Bid Reserve Markets With Strict Delivery Constraints," *IEEE Trans. Power Syst.*, vol. 31, no. 6, pp. 4447–4461, Nov. 2016.
- [4] H. Wu, M. Shahidehpour, A. Alabdulwahab, and A. Abusorrah, "A Game Theoretic Approach to Risk-Based Optimal Bidding Strategies for Electric Vehicle Aggregators in Electricity Markets With Variable Wind Energy Resources," *IEEE Trans. Sustain. Energy*, vol. 7, no. 1, pp. 374–385, Jan. 2016.
- [5] M. Gonzalez Vaya and G. Andersson, "Optimal Bidding Strategy of a Plug-In Electric Vehicle Aggregator in Day-Ahead Electricity Markets Under Uncertainty," *IEEE Trans. Power Syst.*, vol. 30, no. 5, pp. 2375–2385, Sep. 2015.
- [6] M. R. Sarker, Y. Dvorkin, and M. A. Ortega-Vazquez, "Optimal Participation of an Electric Vehicle Aggregator in Day-Ahead Energy and Reserve Markets," *IEEE Trans. Power Syst.*, vol. 31, no. 5, pp. 3506–3515, Sep. 2016.
- [7] P. You, Z. Yang, M.-Y. Chow, and Y. Sun, "Optimal Cooperative Charging Strategy for a Smart Charging Station of Electric Vehicles," *IEEE Trans. Power Syst.*, vol. 31, pp. 2946–2956, Jul. 2016.
- [8] J. Rivera, C. Goebel, and H.-A. Jacobsen, "Distributed Convex Optimization for Electric Vehicle Aggregators," *IEEE Trans. Smart Grid*, vol. 8, no. 4, pp. 1852–1863, Jul. 2017.
- [9] W. Wei, F. Liu, and S. Mei, "Charging Strategies of EV Aggregator Under Renewable Generation and Congestion: A Normalized Nash Equilibrium Approach," *IEEE Trans. Smart Grid*, vol. 7, no. 3, pp. 1630–1641, May 2016.
- [10] O. Erdinc, N. G. Paterakis, T. D. P. Mendes, A. G. Bakirtzis, and J. P. S. Catalao, "Smart Household Operation Considering Bi-Directional EV and ESS Utilization by Real-Time Pricing-Based DR," *IEEE Trans. Smart Grid*, vol. 6, no. 3, pp. 1281–1291, May 2015.
- [11] M. Xia, Q. Lai, Y. Zhong, C. Li, and H.-D. Chiang, "Aggregator-Based Interactive Charging Management System for Electric Vehicle Charging," *Energies*, vol. 9, no. 3, p. 159, Mar. 2016.
- [12] H. Jia, X. Li, Y. Mu, C. Xu, Y. Jiang, X. Yu, J. Wu, and C. Dong, "Coordinated control for EV aggregators and power plants in frequency regulation considering time-varying delays," *Appl. Energy*, Jun. 2017.

- [13] M. R. Sarker, H. Pandzic, and M. A. Ortega-Vazquez, "Optimal Operation and Services Scheduling for an Electric Vehicle Battery Swapping Station," *IEEE Trans. Power Syst.*, vol. 30, no. 2, pp. 901–910, Mar. 2015.
- [14] I. Pavic, T. Capuder, and I. Kuzle, "Low carbon technologies as providers of operational flexibility in future power systems," *Appl. Energy*, vol. 168, pp. 724–738, 2016.
- [15] I. Pavic, T. Capuder, and I. Kuzle, "A Comprehensive Approach for Maximizing Flexibility Benefits of Electric Vehicles," *IEEE Syst. J.*, pp. 1–12, 2017.





## Publication 15

I. Pavić, H. Pandžić, and T. Capuder, “Electric vehicles as frequency containment reserve providers,” in *6th IEEE International Energy Conference, ENERGYCon 2020*, Institute of Electrical and Electronics Engineers Inc., Sep. 2020, pp. 911–917, ISBN: 9781728129563.

DOI: 10.1109/ENERGYCon48941.2020.9236585

# Electric Vehicles as Frequency Containment Reserve Providers

Ivan Pavić

University of Zagreb Faculty of  
Electrical Engineering and Computing  
Zagreb, Croatia  
ivan.pavic@fer.hr

Hrvoje Pandžić

University of Zagreb Faculty of  
Electrical Engineering and Computing  
Zagreb, Croatia  
hrvoje.pandzic@fer.hr

Tomislav Capuder

University of Zagreb Faculty of  
Electrical Engineering and Computing  
Zagreb, Croatia  
tomislav.capuder@fer.hr

**Abstract**—Integration of renewable energy sources accompanied with decommission of fossil fueled power plants inherently results in lack of power system flexibility. In turn, this reduced flexibility calls for additional balancing services. In parallel to this, the process of transport sector electrification is in place and the large fleets of electric vehicles (EVs) could prove to be one of the solutions for increased power system flexibility needs. If managed adequately, EVs could be able to provide the missing balancing services. In this paper, a model of EV day-ahead market and frequency containment reserve bidding is defined in order to assess the potential challenges that could arise during such service provision. Special attention is given to the EV battery state of energy, since the batteries are energy-limited resources and specific issues may arise both at individual EV and fleet level.

**Index Terms**—Electric Vehicles, Electric Vehicle Fleet, Electric Vehicle Aggregator, Frequency Containment Reserve, Primary Reserve

## I. INTRODUCTION

Electrification of the transport sector is in the progress and electric vehicles (EVs) are rapidly increasing their market share. According to [1], EVs' share in total vehicles sales in China in 2018 is more than 4%, while in Europe and USA these numbers are around 2.5%. Document [1] also states that such trend will intensify in the future and a significant effect on power system operation will be obvious since the forecast electricity consumption increase from 2018 to 2030 is 10 to 20 times. Similar conclusions can be found in [2] and [3], where the authors argue that EVs' energy consumption can be supplied with the current infrastructure. However, the problem lies in the high increase in power demand, which could increase the network congestion and create the need for additional peak generation. In order to overcome those issues, the EVs smart charging principle is highly supported. The term smart charging refers to controllable charging (and possible discharging) according to the power system needs. Apart from the issues of simultaneous charging and therefore local and/or global peak demand increase, smart charging is

This paper is funded in part by the Croatian Science Foundation under the projects: Active Neighborhoods energy Markets participation – ANIMATION, Innovative Modelling and Laboratory Tested Solutions for Next Generation of Distribution Networks – IMAGINE, and Flexibility of Converter-based Microgrids – FLEXIBASE.

also seen as a flexibility enhancement tool where EVs are proposed to provide various ancillary services.

Power system flexibility requirements are on the rise due to the heavy decarbonisation measures in the form of Renewable Energy Sources (RES) increase [4], [5], and [6]. In general, wind and solar variability and uncertainty increase ramping and balancing needs. Parallel to the RES increase, decarbonisation also entails decommission of controllable fossil fueled power plants traditionally used for providing flexibility to the power system. Surely, a new flexibility providers must be procured to secure stable and non-disrupted power system operation. This paper discusses how an EV fleet can be used to provide balancing reserve to the transmission system operator through a new model of an aggregated EV fleet, but still respecting all the individual EV behavior and constraints.

Balancing reserves in Europe are divided into automatic and manual. The automatic reserves are Frequency Containment Reserve (FCR) and automatic Frequency Restoration Reserve (aFRR), while the manual reserves are manual Frequency Restoration Reserve (mFRR) and Replacement Reserves (RR). In this paper we focus on FCR, which in the European Union Internal Electricity Balancing Market denote operating reserves necessary for constant containment of frequency deviations (fluctuations) from the nominal value in order to constantly maintain power balance in the whole synchronously interconnected system [7]. The EV FCR provision can bear some additional costs such as investment in bidirectional charging equipment. Profitability of such investment highly depends on the FCR design type, FCR price range and the amount of such investment [8]. The EV aggregator bidding strategies in the day-ahead energy and FCR markets depend on the EV behavior stochasticity. Thus, integrating uncertainty in mathematical models yields higher revenues [9]. FCR is activated when frequency diverges from its nominal value and, from the technical viewpoint, EVs are perfectly able to provide FCR timely and accurately when needed [10]. Apart from the EV behavior uncertainty, the price uncertainty also plays a crucial role in profitability of an EV aggregator bidding strategy in both the day-ahead energy and FCR markets [11]. The high revenue streams from FCR provision can provide sufficient return to cover a significant part of the EV charging costs.

The review shows that different aspects are considered when EVs are observed as energy and reserve market participants. While some of the papers tackle the issue of price or EV behaviour uncertainty none of the takes into account reserve activation uncertainty. The main contribution of this paper is to demonstrate how an EV fleet behaves when providing FCR in developed European markets and how the uncertain FCR activations affect EV and EV fleet SOE. Direct modeling of individual EV constraints and usage of real FCR activation data provides an insight how an EV aggregator should organise its bidding strategy in the DAM and FCR market. The focus of the paper is not to create stochastic bidding model but to check how such uncertainty affects the EV fleet and individual EVs in the real time.

## II. MATHEMATICAL FORMULATION

### A. Nomenclature

#### 1) Sets and Indices:

$\mathcal{T}$	Set of time steps, indexed by $t$ .
$\mathcal{V}$	Set of vehicles, indexed by $v$ .
$\mathcal{CP}$	Set of charging points, indexed by $cp$ .

#### 2) Input parameters:

$A_{s,t}^{UP\_FCR}$	Up FCR activation vs reservation ratio for $s$ at $t$ ,
$A_{s,t}^{DN\_FCR}$	Down FCR activation vs reservation ratio for $s$ at $t$ ,
$C_v^{BAT}$	Capital battery cost of vehicle $v$ (€).
$C_t^{FCH}$	Fast charging fee (€/kWh).
$C_t^{DAM}$	Day-ahead market electricity price at $t$ (€/kWh).
$CR_t^{UP\_RES}$	Reservation fee for either upward FCR or aFRR at $t$ (€/kW),
$CR_t^{DN\_RES}$	Reservation fee for either downward FCR or aFRR at $t$ (€/kW),
$CAP_v^{BAT}$	Battery capacity of vehicle $v$ (kWh).
$D_{1,2,3,4}^{BAT}$	Battery degradation coefficients.
$E_{v,t}^{CP\_MAX}$	Maximum energy limit for $v$ at $t$ due to charging point installed power limits (kWh).
$E_{v,t}^{OBC\_MAX}$	Maximum energy limit for $v$ at $t$ due to on-board-charger installed power limits (kWh).
$E^{FCH\_MAX}$	Maximum energy limit for fast charging point (kWh) at certain time-step.
$E_{v,t}^{RUN}$	Energy consumed for mobility purposes in vehicle $v$ at $t$ (kWh).
$SOE_v^{MIN}$	Minimum allowed SOE of vehicle $v$ (%).
$SOE_v^{MAX}$	Maximum allowed SOE of vehicle $v$ (%).
$SOE_v^0$	Initial SOE of vehicle $v$ (%).
$SOE^{CV}$	Constant voltage charging phase knee point (%).
$\eta^{DCH}$	EV V2G discharging efficiency.
$\eta^{FCH}$	EV fast charging efficiency.
$\eta^{RUN}$	EV mobility discharging efficiency.
$\eta^{SCH}$	EV slow charging efficiency.
3) Variables:	
$e_{v,t}^{BUY\_DAM}$	Energy bought for $v$ at $t$ on the day-ahead market (kWh).
$e_{v,t}^{SELL\_DAM}$	Energy sold from $v$ at $t$ on the day-ahead market (kWh).

$c_{v,t}^{DEG}$	Degradation cost of vehicle $v$ at time $t$ (€).
$c_{v,t}^{DCH}$	Energy discharged from vehicle $v$ at $t$ (kWh).
$c_{v,t}^{FCH}$	Energy fast charged to vehicle $v$ at time $t$ (kWh).
$c_{v,t}^{SCH}$	Energy slow charged to vehicle $v$ at time $t$ (kWh).
$soe_{v,t}^{EV}$	State-of-energy of vehicle $v$ at time $t$ (kWh).
$r_{v,t}^{UP\_FCR}$	Reserved capacity of $v$ at $t$ on either upward FCR or aFRR market.
$r_{v,t}^{DN\_FCR}$	Reserved capacity of $v$ at $t$ on either downward FCR or aFRR market.
$r_{v,t}^{UP}$	Maximum capacity of $v$ at $t$ in upward direction.
$r_{v,t}^{DN}$	Maximum capacity of $v$ at $t$ in downward direction.

### B. Mathematical Model

The mathematical model is a minimization of the energy cost purchased in the DAM minus the sold FCR up and down capacities.

$$\min_{\text{OF}} c^{EVBA} = \sum_{t=1}^{N_t} \sum_{v=1}^{N_v} e_{v,t}^{BUY\_DAM} \cdot C_t^{DAM} - e_{v,t}^{SELL\_DAM} \cdot C_t^{DAM} - r_{v,t}^{UP\_FCR} \cdot CR_t^{UP\_FCR} - r_{v,t}^{DN\_FCR} \cdot CR_t^{DN\_FCR} + e_{v,t}^{FCH} \cdot C_t^{FCH} + c_{v,t}^{DEG} \quad (1)$$

Amount of capacities which could be traded is limited with charging/discharging power/energy constraints:

$$e_{v,t}^{BUY\_DAM}, e_{v,t}^{SELL\_DAM} \geq 0 \quad \forall v, t \in V, T; \quad (2)$$

$$r_{v,t}^{UP\_FCR}, r_{v,t}^{DN\_FCR} \geq 0 \quad \forall v, t \in V, T; \quad (3)$$

$$r_{v,t}^{UP}, r_{v,t}^{DN} \leq E_v^{OBC\_MAX} \quad \forall v, t \in V, T; \quad (4)$$

$$r_{v,t}^{UP}, r_{v,t}^{DN} \leq E_{v,t,cp}^{CP\_MAX} \quad \forall v, t, cp \in V, T, CP; \quad (5)$$

$$r_{v,t}^{UP} \leq soe_{s,v,t}^{EV} - SOE^{MIN} \cdot CAP_v^{BAT} \quad \forall s, v, t \in S, V, T; \quad (6)$$

$$r_{v,t}^{DN} \leq SOE^{MAX} \cdot CAP_v^{BAT} - soe_{s,v,t}^{EV} \quad \forall s, v, t \in S, V, T; \quad (7)$$

$$r_{v,t}^{DN} \leq E_v^{OBC\_MAX} \cdot \frac{1 - soe_{s,v,t}^{EV}}{1 - SOE^{CV} \cdot CAP_v^{BAT}} \quad \forall s, v, t \in S, V, T; \quad (8)$$

$$r_{v,t}^{UP} \geq e_{v,t}^{SELL\_DAM}/DT - e_{v,t}^{BUY\_DAM}/DT + r_{v,t}^{UP\_FCR} \quad \forall v, t \in V, T; \quad (9)$$

$$r_{v,t}^{DN} \geq e_{v,t}^{BUY\_DAM}/DT - e_{v,t}^{SELL\_DAM}/DT + r_{v,t}^{DN\_FCR} \quad \forall v, t \in V, T; \quad (10)$$

$$e_{s,v,t}^{CH} - e_{s,v,t}^{DCH} = e_{v,t}^{BUY\_DAM} - e_{v,t}^{SELL\_DAM} + r_{v,t}^{DN\_FCR} \cdot A_{s,t}^{DN\_FCR} \cdot DT - r_{v,t}^{UP\_FCR} \cdot A_{s,t}^{UP\_FCR} \cdot DT \quad \forall s, v, t \in S, V, T; \quad (11)$$

$$e_{v,t}^{FCH} \leq E_t^{FCH\_MAX} \quad \forall v, t \in V, T; \quad (12)$$

Eqs. (2) and (3) set the four bidding variables as positive. Eq. (4) constrains the charging/discharging power to the On-Board Charger (OBC) capacity, while eq. (5) constrains the

charging/discharging power to the Charging Point (CP) capacity. Variables  $r^{\text{DN}}$  and  $r^{\text{UP}}$  refer to maximal power that an EV can charge (or go down) and discharge (or go up), respectively, while  $r^{\text{DN\_FCR}}$  and  $r^{\text{UP\_FCR}}$  refer to bids for FCR down and up provision, respectively. Eqs. (6) and (7) limit the maximum discharging and charging power considering minimum/maximum State-Of-Energy (SOE). Charging power is additionally constrained in eq. (8) for higher values of SOE due to reduced charging speed at the constant voltage phase of the li-ion battery charging process. Eqs. (9) and (10) allocate the maximum discharging/charging power between the DAM Sell/Buy ( $e_{v,t}^{\text{SELL\_DAM}}$  and  $e_{v,t}^{\text{BUY\_DAM}}$ ) energy and FCR DN/UP reserve activations ( $r_{v,t}^{\text{DN\_FCR}} \cdot A_{s,t}^{\text{DN\_FCR}} \cdot DT$  and  $r_{v,t}^{\text{UP\_FCR}} \cdot A_{s,t}^{\text{UP\_FCR}} \cdot DT$ ). Parameters  $A_{s,t}^{\text{DN\_FCR}}$  and  $A_{s,t}^{\text{UP\_FCR}}$  are calculated based on the ratio of total accepted FCR UP/DN reserve and actual activated reserves.

$$c_{s,v,t}^{\text{DEG}} \geq C_v^{\text{BAT}} \cdot (D_1^{\text{BAT}} + D_2^{\text{BAT}} \cdot \frac{e_{s,v,t}^{\text{DCH}}}{CAP_v^{\text{BAT}}} \cdot 100 + D_3^{\text{BAT}} \cdot \frac{1 - soe_{s,v,t}^{\text{EV}}}{CAP_v^{\text{BAT}}} \cdot 100) \quad \forall s, v, t \in S, V, T; \quad (13)$$

$$c_{s,v,t}^{\text{DEG}} \geq C_v^{\text{BAT}} \cdot (D_4^{\text{BAT}} \cdot \frac{e_{s,v,t}^{\text{DCH}}}{CAP_v^{\text{BAT}}} \cdot 100) \quad \forall s, v, t \in S, V, T; \quad (14)$$

Li-ion batteries are prone to degradation, especially when cycled often. Thus, the degradation is taken into account when providing energy discharging. Eqs. (13) and (14) calculate Vehicle-to-Grid (V2G) discharging degradation cost.

$$soe_{v,t}^{\text{EV}} = soe_{v,t-1}^{\text{EV}} + e_{v,t}^{\text{CH}} \cdot \eta^{\text{CH}} - e_{v,t}^{\text{DCH}} / \eta^{\text{DCH}} - E_{v,t}^{\text{RUN}} / \eta^{\text{RUN}} + e_{v,t}^{\text{FCH}} \cdot \eta^{\text{FCH}} \quad \forall v, t \in V, T (t \neq 1); \quad (15)$$

$$soe_{v,t}^{\text{EV}} \geq SOE^{\text{MIN}} \cdot CAP_v^{\text{BAT}} \quad \forall v, t \in V, T; \quad (16)$$

$$soe_{v,t}^{\text{EV}} \leq SOE^{\text{MAX}} \cdot CAP_v^{\text{BAT}} \quad \forall v, t \in V, T; \quad (17)$$

$$soe_{v,t}^{\text{EV}} \geq SOE^{\text{T0}} \cdot CAP_v^{\text{BAT}} \quad \forall v \in V, h = 24; \quad (18)$$

Eq. (15) calculates the current SOE based on the SOE from the previous timestep, amounts of charged and discharged energy, energy used for driving ( $E_{\text{RUN}}$ ) and energy used for fast charging when there is insufficient energy to complete the trip ( $e_{\text{FCH}}$ ). Eqs. (16) and (17) limit the SOE of a battery to its minimum and maximum capacities, while eq. (18) sets the final SOE to its initial value.

### III. INPUT DATA AND CASE STUDIES

The simulations are carried out in two stages. The first stage is designed without FCR activation scenarios with day-ahead EV schedules only. This is achieved by neglecting the FCR activation energy in eq. (11), i.e. the amount of activated

TABLE I: Electric Vehicle (EV) Type Data

EV Type	Battery Capacity	OCB Rated Power	Battery Price	Fleet Share
Small	20 kWh	3.7 kW	€3250	30
Medium	40 kWh	7.4 kW	€6500	40
Large	60 kWh	11 kW	€9750	30

energy from FCR in the first stage is zero. The second stage is run after the first stage and it embodies the real-time realizations of FCR activation. Ten scenarios of simulated FCR realizations are utilized while the accepted DAM energy and FCR bids from the first stage are held fixed. The simulations are run for one day with half-hour time step, while the DAM and FCR bids are modeled as one-hour products. The model was formulated as linear program in Fico Xpress optimization environment and run on a typical PC.

#### A. Input data

The data used to model EV behavior is taken from the Joint Research Center European driving study [12], [13], [14], and [15]. Three EV types were modeled and their data is show in Table I. Three slow charging points were modeled with power ratings of 3.7, 7.4 and 11 kW. Fast charging was modeled as 50 kW. DAM and FCR market prices as well as activation data are from the French power system on Nov. 21, 2018 (EPEX and RTE data). This day is specifically chosen as it had the highest volatility of DAM prices within one day in 2018. The activation scenarios are calculated based on probability density functions created from the RTE 2018 data of FCR accepted capacity bids and FCR activated energies using equations:

$$A^{\text{UP\_FCR}} = \frac{\text{Activated UP FCR energy}}{\text{Accepted FCR UP capacity} \cdot DT} \quad (19)$$

$$A^{\text{DN\_FCR}} = \frac{\text{Activated DN FCR energy}}{\text{Accepted DN FCR capacity} \cdot DT} \quad (20)$$

Efficiencies used in this paper are as following; slow charging  $\eta^{\text{SCH}} = 0.95$ , discharging for driving  $\eta^{\text{RUN}} = 0.90$ , discharging as V2G  $\eta^{\text{DCH}} = 0.85$ , and fast charging  $\eta^{\text{FCH}} = 0.80$ . SOE parameters used for all EVs are following:  $SOE^{\text{MAX}} = 1$ ,  $SOE^{\text{MIN}} = 0.2$ ,  $SOE^{\text{CV}} = 0.8$ , and  $SOE^{\text{T0}} = 0.4$ . Battery degradation parameters:  $D_1^{\text{BAT}} = -0.3429$ ,  $D_2^{\text{BAT}} = 0.03403$ ,  $D_3^{\text{BAT}} = 0.004287$ , and  $D_4^{\text{BAT}} = 0.008317$ .

#### B. Case Studies

For the same input data seven different charging and FCR product modes are observed:

- 1) Dumb or uncontrolled charging: EVs immediately charge after the plugging to the charging point and charge until fully charged ;
- 2) G2V no FCR: unidirectional controllable charging without the possibility of FCR provision,
- 3) G2V S FCR: unidirectional controllable charging with the possibility of symmetrical FCR provision,
- 4) G2V A FCR: unidirectional controllable charging with the possibility of asymmetrical FCR provision,
- 5) V2G no FCR: bidirectional controllable charging without the possibility of FCR provision,
- 6) V2G S FCR: bidirectional controllable charging with the possibility of symmetrical FCR provision,
- 7) V2G A FCR: bidirectional controllable charging with the possibility of asymmetrical FCR provision,

TABLE II: Different Charging Modes Results

	Dumb	G2V no FCR	G2V S FCR	G2V A FCR	V2G no FCR	V2G S FCR	V2G A FCR
OF Value	652.75	329.49	267.38	-359.39	175.02	-1030.19	-1201.80
Fleet SOE Mean [%]	63.87	64.29	64.11	76.60	73.06	71.39	67.55
Over SOE <sub>max</sub> [#]	0	0	22	3263	0	306	11
Over SOE <sub>max</sub> [MWh]	0	0	0.00	3.35	0	0.09	0.00
Under SOE <sub>min</sub> [#]	0	0	1790	225	0	1058	2358
Under SOE <sub>min</sub> [MWh]	0	0	1.95	0.21	0	1.70	4.75

#### IV. RESULTS

The acquired results are shown in Table II through 6 comparable parameters:

- i. OF Value: First stage objective function value in Euros;
- ii. SOE Mean [%]: Mean SOE in percent for the whole fleet and through all scenarios,
- iii. Over [#]: Number of timesteps when SOE of individual EV exceeds its maximum SOE,
- iv. Over [MWh]: Sum of energy in timesteps when SOE of individual EV exceeds its maximum SOE, i.e. the energy which cannot be stored in specific EV as planned one day ahead of delivery,
- v. Under [#]: Number of timesteps when SOE of individual EV falls behind its minimum SOE,
- vi. Under [#]: Sum of energy in timesteps when SOE of individual EV falls behind its minimum SOE, i.e. energy that cannot be withdrawn from the EV as planned one day before the delivery.

##### A. Costs and Bids

As displayed in Table II, adding controllability, either through V2G discharging or through FCR provision, decreases overall charging costs of the EV fleet. Unidirectional control without FCR reserve provision splits the total cost in half compared to the dumb charging, while symmetrical FCR provision yields additional 10% in total cost decrease. The overall cost turns to profit in the case of G2V asymmetrical FCR provision.

Cost of V2G without FCR provision is less than a third of the dumb charging cost and around 50% of G2V no FCR cost. Adding FCR provision to V2G charging creates profits for users where asymmetrical provision is identified as the financially most attractive option. V2G A FCR mode yields 3.3 times higher revenue compared to G2V A mode.

Reasons for such OF value distribution through modes 3), 4), 6) and 7) is further illustrated in Figures 1, 2, 3 and 4. The DAM and FCR bids of the EV fleet are shown in sub-figures a). As shown in Figure 1, G2V S mode is heavily constrained and can offer FCR only when DAM charging takes place (only in the morning price valley). G2V A mode is released of the symmetry constraint and can therefore provide continuous FCR down reserve and occasional up reserve while the fleet is charging (Figure 2). Allowing V2G discharging enables (see Figures 3 and 4) continuous up and down FCR provision when the EVs are in the idle status (not charging, discharging or driving). Additional benefit of V2G A mode

compared to V2G S mode is more available FCR provision in a fleet's charging/discharging period.

##### B. Fleet SOE

The mean fleet SOE is around 64% for the first three modes (Table II) and it increases significantly for G2V A FCR mode because provision is asymmetrical and only in the direction of additional charging (up reserve). The three V2G cases are in between the previously mentioned cases since V2G cases keep SOE a bit higher to be able to discharge later in the day, but not as high as the SOE increased during the G2V A FCR case.

The stochastics behind the FCR activation and SOE behaviour are displayed in sub-figures b), which display the mean fleet SOE during the day (measure units in % on the left x axis) and error in the form of difference of the real mean SOE after activation and planned day-ahead mean SOE (measure units in MWh on the right x axis) for all observed scenarios. Since there is only low FCR reservation in the G2V S mode, the SOE deviation is negligible (Fig. 1). On the other hand, G2V A mode provides FCR in only one direction and the error in fleet SOE significantly increases, but the mean SOE value never exceeds the upper SOE limit (Fig. 2). In V2G modes, Figures 3 and 4, the error exists in both directions, depending on how activation unfolds in a specific scenario. The asymmetrical case, since its activation is not balanced in up and down directions, suffers from slightly more deviations in the fleet SOE.

##### C. Individual EV SOE

The results tackling the individual EV SOE issues are presented in Table II (last four rows) and subfigures c). Rows *Over SOE<sub>max</sub> [#]*/*Under SOE<sub>min</sub> [#]* and *Under SOE<sub>min</sub> [MWh]* show the number of timesteps when the amount of total energy EVs exceed their SOE maximum or minimum value. It could be concluded that the SOE of individual EVs rarely exceeds their limits in all modes except G2V A FCR mode, which pushes the SOE for quite a number of EVs over the upper SOE bound. Subfigures c) display three lines, the upper/lower line shows the EV with highest/lowest SOE in a specific timestep observing all scenarios and the entire fleet. The medium line shows the planned mean day-ahead SOE curve for the entire fleet.

The upper conclusion can be confirmed in subfigures c), where in all figures except Fig. 2 the highest SOE is around SOE<sub>max</sub>. In G2V A mode, the highest SOE is mostly above the SOE limit, in some timesteps close to 125%. For the lower



SOE bound, the conclusions are contrary. G2V A FCR mode yields the lowest number of periods when EVs' SOE fall below the lower limit (however the number and energy below this threshold is not negligible). G2V S FCR mode provides a very small capacity in the FCR market but EVs whose SOE descend below the minimum threshold is very high, even higher than in the case of V2G S FCR mode. However, when we compare the minimum amount an individual EV SOE reaches in those two modes, Figs. 3 and 1 indicate that in V2G S FCR mode the worst SOE falls below 0%, while in G2V S FCR mode it never falls below 5%.

V2G A FCR mode is the most profitable one, but it is followed by the highest issues when observing the individual EV SOE minimum limits. The total under SOE energy is 2.8 and 2.4 times higher than in G2V S and V2G S modes, respectively.

#### D. Realized Charging/Discharging of a Fleet

Subfigures *d)* show the amount of total realized charging/discharging energy of the fleet in different scenarios and the maximum energy that can be charged/discharged by the fleet. In both the G2V cases, the charging energy is much lower than its maximum. In V2G cases, during charging/discharging periods, it almost reaches maximum in both directions to retain as much profit as possible from the highest price difference during the day.

### V. CONCLUSION

This paper observes how the individual EV and EV fleet SOE behave during the FCR reserve provision. It can be seen that neglecting the FCR activation during the scheduling process satisfies the SOE boundaries at the fleet level, but leads to infeasible SOE states of individual EVs. This issue can be reinterpreted in the following way: in periods when individual EVs' SOE exceeds/fall below its limits, the aggregator would in reality be unable to provide the scheduled reserve and suffer from penalties imposed by the system operator. To solve this issue the EV aggregator should use the intraday market to revert to its scheduled operating point. Additionally, sophisticated re-dispatching algorithms that can activate another EV if the scheduled EV is not able to provide the scheduled service are needed. One of the options is to include the FCR activation stochastics in the day-ahead scheduling algorithm and decrease the number of EVs potentially charging or discharging into infeasible SOE values.

The final conclusion is that the real value of V2G dispatching does not lie in selling energy but in creating as wide as possible capacity for FCR reserve provision.

### REFERENCES

- [1] International Energy Agency, "Global EV Outlook 2019," 2019.
- [2] European Distribution System Operators for Smart Grids, "Smart charging: integrating a large widespread of electric cars in electricity distribution grids," 2018.
- [3] Eurelectric, "Smart Charging – Key to unlocking Electro-mobility's potential," Brussels, 2017.
- [4] N. E. Koltsaklis, A. S. Dagoumas, and I. P. Panapakidis, "Impact of the penetration of renewables on flexibility needs," *Energy Policy*, vol. 109, pp. 360–369, Oct. 2017.
- [5] E. Ela, M. Milligan, and B. Kirby, "Operating Reserves and Variable Generation," Cole Boulevard Golden, 2011.
- [6] M. MacDonald, "Impact Assessment on European Electricity Balancing Market," Brighton, 2013.
- [7] "Frequency Containment Reserve (FCR)." [Online]. Available: <https://www.emissions-euets.com/internal-electricity-market-glossary/793-frequency-containment-reserve>. [Accessed: 30-Nov-2019].
- [8] O. Borne, M. Petit, and Y. Perez, "Net-Present-Value Analysis for Bidirectional EV Chargers Providing Frequency Containment Reserve," in 2018 15th International Conference on the European Energy Market (EEM), 2018, pp. 1–6.
- [9] T. Soares, T. Sousa, P. B. Andersen, and P. Pinson, "Optimal Offering Strategy of an EV Aggregator in the Frequency-Controlled Normal Operation Reserve Market," in 2018 15th International Conference on the European Energy Market (EEM), 2018, pp. 1–6.
- [10] S. Hashemi, N. B. Arias, P. Bach Andersen, B. Christensen, and C. Traholt, "Frequency Regulation Provision Using Cross-Brand Bidirectional V2G-Enabled Electric Vehicles," in 2018 IEEE International Conference on Smart Energy Grid Engineering (SEGE), 2018, pp. 249–254.
- [11] L. Herre, J. Dalton, and L. Soder, "Optimal Day-Ahead Energy and Reserve Bidding Strategy of a Risk-Averse Electric Vehicle Aggregator in the Nordic Market," in 2019 IEEE Milan PowerTech, 2019, pp. 1–6.
- [12] "EU Science Hub - European Commission." [Online]. Available: <https://ec.europa.eu/jrc/en>. [Accessed: 30-Nov-2018].
- [13] G. Pasaoglu, D. Fiorello, A. Martino, G. Scarcella, A. Alemanno, A. Zubaryeva, C. Thiel, and L. P. O. of the E. Union, "Driving and parking patterns of European car drivers - a mobility survey" 2012.
- [14] C. Thiel, A. Alemanno, G. Scarcella, A. Zubaryeva, and G. Pasaoglu, "Attitude of European car drivers towards electric vehicles: a survey," JRC Rep., p. 28, 2012.
- [15] G. Pasaoglu, D. Fiorello, L. Zani, A. Martino, A. Zubaryeva, and C. Thiel, "Projections for Electric Vehicle Load Profiles in Europe Based on Travel Survey Data Contact information", vol. 1. 2013.

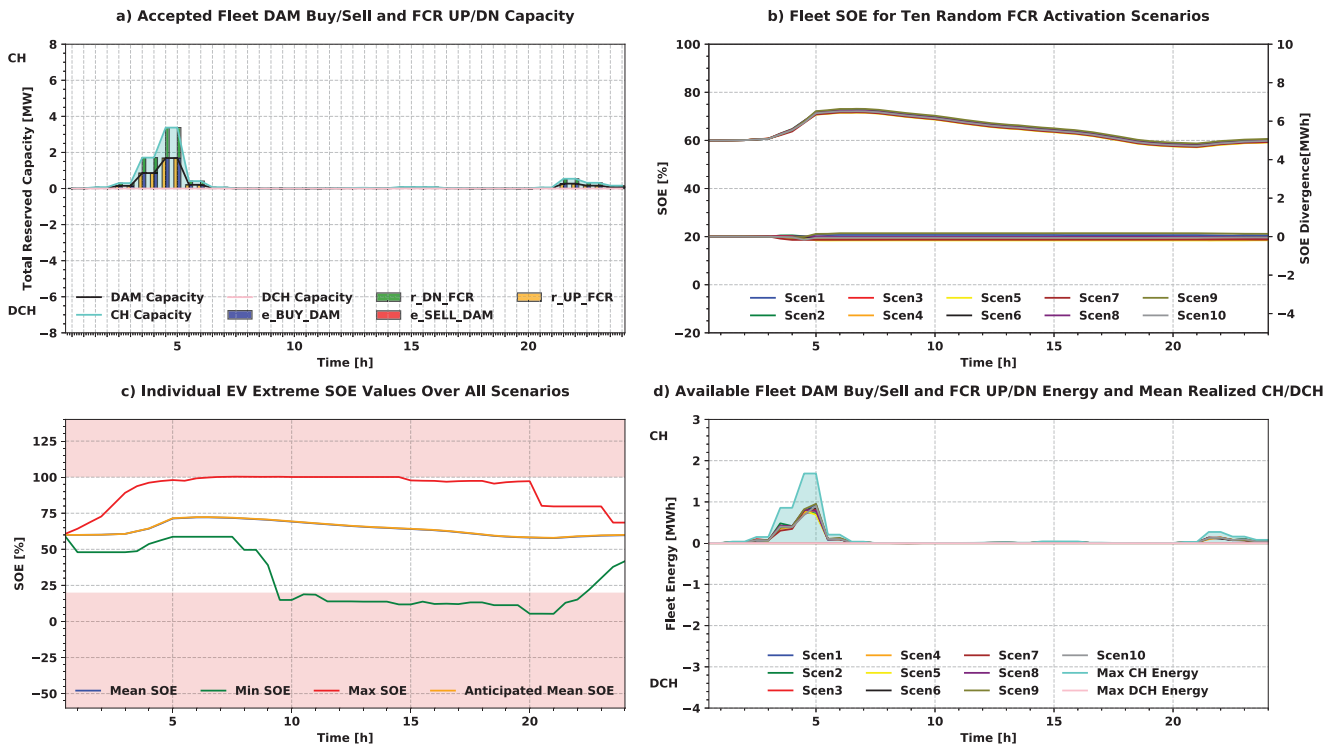

Fig. 1: Results for G2V Symmetric FCR Provision

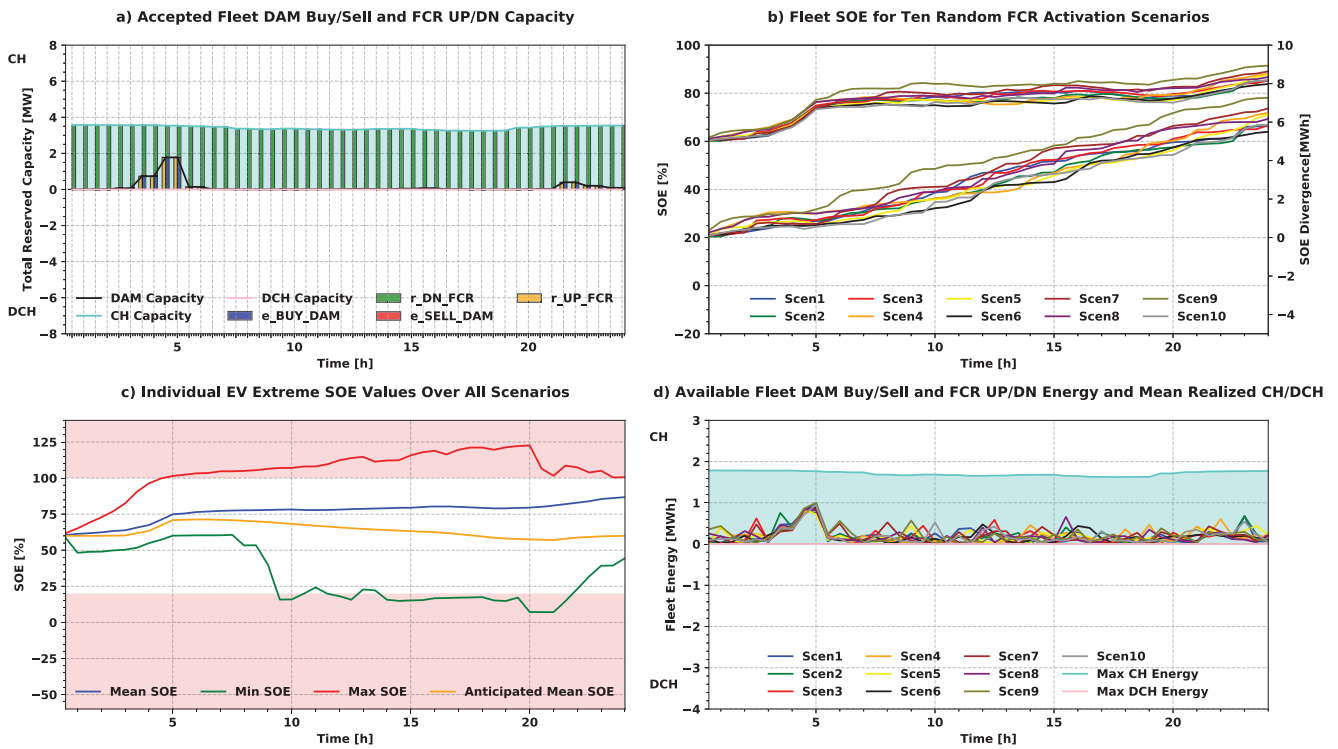

Fig. 2: Results for G2V Asymmetric FCR Provision



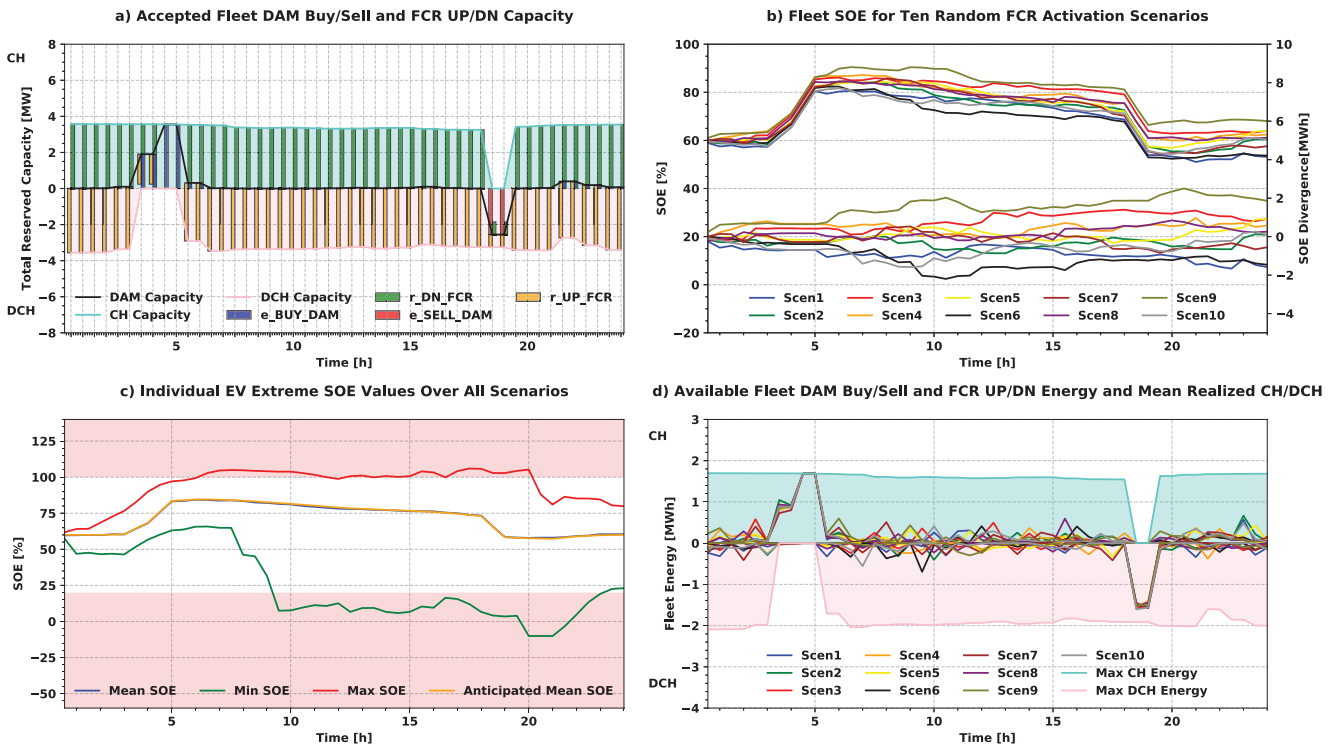

Fig. 3: Results for V2G Symmetric FCR Provision

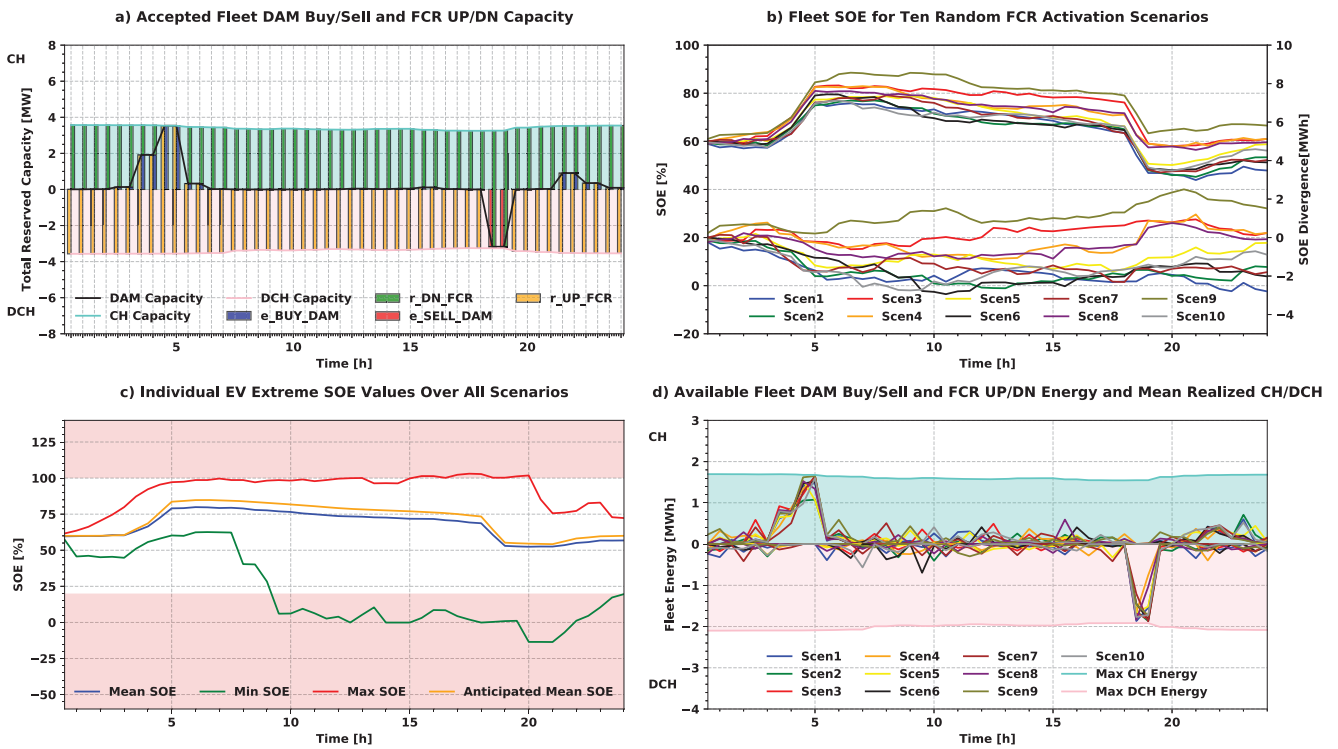

Fig. 4: Results for V2G Asymmetric FCR Provision

## **Publication 16**

I. Pavić, H. Pandžić, and T. Capuder, “Tight Robust Formulation for Uncertain Reserve Activation of an Electric Vehicle Aggregator,” in *2021 IEEE PowerTech*, Madrid, 2021, pp. 1–6

# Tight Robust Formulation for Uncertain Reserve Activation of an Electric Vehicle Aggregator

Ivan Pavić, Hrvoje Pandžić, Tomislav Capuder  
University of Zagreb, Faculty of Electrical Engineering and Computing  
Zagreb, Croatia  
ivan.pavic@fer.hr, hrvoje.pandzic@fer.hr, tomislav.capuder@fer.hr

**Abstract**—Power system decarbonisation is closely followed by the liberalization of ancillary services to secure a sufficient volume of services at all times. In Europe, system operators are adjusting ancillary services markets to allow entrance of new players. Reserves are the first ones to be liberalized and one of their potential providers are electric vehicles. They can decrease their charging costs through reserve provision under negligible affect on users comfort. However, reserves are highly intertwined with uncertainty and depend on many parameters. To adequately address these uncertainties and safely bid in the markets, an aggregator must adequately integrate them in its optimal bidding algorithm. In this paper, a new robust model is proposed where a tight uncertainty set of reserve activation is created using a realistic reserve activation dataset. The tight robust framework is analysed on the electric vehicle fleet operation under one aggregator. A sensitivity analysis is performed to find adequate boundaries of the uncertainty set. The results show that robust approach can be used to adequately address this uncertainty allowing the aggregator to choose its risk exposure and hedging strategy. Also, the results show that neglecting more than 1% of the most extreme activation volumes could lead towards too liberal models not securing the battery limits adequately.

**Index Terms**—Aggregator, Electric Vehicles, Frequency Containment Reserve, Frequency Restoration Reserve

## I. INTRODUCTION

Electric Vehicle (EV) numbers are exponentially growing and they are expected to take up to 30% of the market share worldwide by 2030 [1]. While the EVs' passive charging can harm the power system, smart charging can bring new flexibility and help the system operate more efficiently [2], [3]. In Europe, power system balancing is based on four main types of reserves: Frequency Containment Reserve (FCR), automatic Frequency Restoration Reserve (aFRR), manual Frequency Restoration Reserve (mFRR) and Replacement Reserve (RR). FCR and aFRR are fast reserves with frequent and short activations, while mFRR and RR are slower with rare and long activations [4]. In this paper only the automatically activated reserves will be addressed as they are technically more suited for battery systems [5] and can bring higher revenues [6].

This work has been supported in part by the European Structural and Investment Funds under project KK.01.2.1.02.0063 SUPER (System for optimization of energy consumption in households), as well as by the Croatian Science Foundation and European Union through the European Social Fund under project Flexibility of Converter-based Microgrids – FLEXIBASE (PZS-2019-02-7747).

Electricity market participants can be affected by different uncertainties stemming from physical or financial conditions. In case of EVs providing reserve, three uncertainty threads can be addressed: EV behavior, prices and reserve activation dynamics. The EV behavior can be modeled using scenarios [7], [8], [9], [10] and solved by second-stage markets [11], [12]. Price uncertainties are often addressed by stochastic [7], [9] or robust frameworks [13]. The last group of uncertainties is often modeled as fixed probability of activation [11], [13], [14] or as stochastic models where scenarios are generated randomly and uniformly [7], [8], [15]. Some more advanced models includes usage of automatic generation control (AGC) signal to design the activation scenarios through a truncated Gaussian distribution [10] or a robust model tackling the worst case scenario of the manual reserve activation [13]. It is worth noting that most of the referenced papers (except [12]) target the United States markets, while European (EU) energy and ancillary service markets are outside of the focus.

The problem of uncertain reserve activation is more prominent than ever before as the structure of reserve providers changed from controllable power plants to distributed resources with constrained possibilities. The EVs' main source of flexibility are their batteries, but at the same time the batteries' state-of-energy (SOE) limits are the most affected parameters when reserve is activated during the real-time. Fixed probabilities or scenarios not based on real activation data do not faithfully represent the uncertainty and the EVs can be forced to dive into unplanned SOE levels, to recharge on other (often more expensive) markets or to be unable to provide the contracted services. The inability to provide the agreed day-ahead (DA) energy would cause additional balancing costs, whereas the inability to deliver the contracted reserve would lead to penalization [10], [14], [15] and potential disqualification. In order to prevent these unwanted events the uncertain nature of reserve activation should be addressed adequately. Activation scenarios based on real data such as Automatic Generation Control – AGC (appropriate for USA markets [10]) or on publicly available balancing data in Europe (ENTSO-e transparency platform) are one of the solutions. However, scenarios can be difficult to create and computationally burdensome. What is more important, such models fail to provide the decision-maker the flexibility in terms of a compromise between the uncertainty and the cost. On the other hand, the robust formulation is not affected by

those issues and as such can be more relevant for this type of problems. A prior work in the area focused on the type of reserves where the number of calls during the day is an integer value accompanied with a binary value for each call meaning that reserve will be either fully activated or not [13]. However, this representation resembles manual reserves and not automatic that are more suitable for EVs.

We argue that there is a scientific gap concerning the modeling of reserve activation uncertainty and thus we propose a new robust framework for EU-style markets based on real balancing data. The focus of the paper is only on reserve activation uncertainty to isolate this concrete issue, but the model can be easily expanded with price or behavior uncertainties explained in the above-referenced papers. The main contribution of the paper is threefold:

- 1) Reserve activation uncertainty set design based on real activated energy and reserved capacity from EU markets;
- 2) A new tight robust formulation for the EV fleet automatic reserve bidding;
- 3) A sensitivity analyses of the robust set parameters affecting the EV fleet and individual EV SOE behavior.

The structure of the paper is the following: Section II defines and explains the mathematical background, Section III identifies the input parameters and elaborates the case studies, while Section IV highlights the most important findings.

## II. MATHEMATICAL FRAMEWORK

Two models for an EV fleet optimal scheduling are conceived: the deterministic one and the robust one. The deterministic model stands as the basis for the robust design.

### A. Nomenclature

#### 1) Sets and Indices:

$\mathcal{S}$	Set of scenarios, indexed by $s \in [1, N_s]$ ,
$\mathcal{T}$	Set of time steps, indexed by $t \in [1, N_t]$ ,
$\mathcal{V}$	Set of vehicles, indexed by $v \in [1, N_v]$ .

#### 2) Input Parameters:

$\Delta$	Duration of a time-step [h],
$\Lambda$	Full duration of reserve activation,
$A^{\{\text{UP/DN}\}_{\text{FCR/aFRR}}}$	Fixed Up/Dn FCR/aFRR activation ratio,
$C_v^B$	Capital battery cost of vehicle $v$ [€],
$C_{v,t}^{\text{FCH}}$	Fast charging fee [€/kWh],
$C_t^{\text{DAM}}$	DA market electricity price at $t$ [€/kWh],
$B_v$	Battery capacity of vehicle $v$ [kWh],
$CA_t^{\{\text{UP/DN}\}_{\text{FCR/aFRR}}}$	Activation fee at $t$ [€/kWh],
$CR_t^{\{\text{UP/DN}\}_{\text{FCR/aFRR}}}$	Reservation fee at $t$ [€/kW/Δ],
$D_{\{1/2/3/4\}}^B$	Battery degradation coefficients,
$E_{v,t}^{\text{RUN}}$	Energy used for driving in vehicle $v$ at $t$ [kWh],
$P_{v,t}^{\text{CP\_MAX}}$	Maximum power limit for ch. stations $v$ at $t$ [kW],
$P_{v,t}^{\text{FCH\_MAX}}$	Maximum power limit for fast charging [kW],
$P_{v,t}^{\text{OBC\_MAX}}$	Maximum power limit for OBC of $v$ [kW],
$SOE_v^{\{\text{MIN/MAX}\}}$	Min/max allowed SOE of vehicle $v$ [%],
$SOE_v^{\text{TO}}$	Initial SOE of vehicle $v$ [%],
$\eta^{\{\text{SCH/FCH}\}}$	EV slow/fast charging efficiency.
$\eta^{\{\text{RUN/DCH}\}}$	EV mobility/V2G discharging efficiency,

### 3) Variables:

$e_{v,t}^{\text{DEG}}$	Degradation cost of vehicle $v$ at time $t$ [€],
$e_{v,t}^{\{\text{BUY/SELL}\}_{\text{DAM}}}$	Energy bought/sold in DA market [kWh],
$e_{v,t}^{\text{DCH}}$	Energy discharged from vehicle $v$ at $t$ [kWh],
$e_{v,t}^{\{\text{SCH/FCH}\}}$	Energy slow/fast charged to EV $v$ at time $t$ [kWh],
$e_{v,t}^{\text{DEG}}$	Energy flow in/out battery used for degradation,
$f$	Sum of costs other than reserve activation [€],
$g$	Sum of costs of reserve activation [€],
$h_{v,t}$	Energy flow not from reserve activation [MWh],
$k_{v,t}$	Energy flow from reserve activation [MWh],
$r_{v,t}^{\{\text{UP/DN}\}_{\text{FCR/aFRR}}}$	Sold reserve capacity of EV $v$ at $t$ [kW],
$soe_{v,t}^{\text{EV}}$	State-of-energy of EV $v$ at time $t$ [kWh].

### B. Deterministic Model

The deterministic model takes a fixed activation ratio based on average activation of specific reserve type and direction [16]. The objective function (OF) includes costs/revenues from the energy market, revenues from the reserve capacity, the V2G degradation cost, the fast charging cost and the costs/revenues of activated reserve energy. The first four costs are summed in eq. (D-2), while the costs associated with reserve activation are summed in eq. (D-3). Objective function:

$$f = \sum_{t=1}^{N_t} \left\{ \sum_{v=1}^{N_v} \left[ e_{v,t}^{\text{BUY\_DAM}} \cdot C_t^{\text{DAM}} - e_{v,t}^{\text{SELL\_DAM}} \cdot C_t^{\text{DAM}} - r_{v,t}^{\text{UP\_FCR}} \cdot CR_t^{\text{UP\_FCR}} - r_{v,t}^{\text{DN\_FCR}} \cdot CR_t^{\text{DN\_FCR}} - r_{v,t}^{\text{UP\_aFRR}} \cdot CR_t^{\text{UP\_aFRR}} - r_{v,t}^{\text{DN\_aFRR}} \cdot CR_t^{\text{DN\_aFRR}} + c_{v,t}^{\text{DEG}} + e_{v,t}^{\text{FCH}} \cdot C_{v,t}^{\text{FCH}} \right] \right\}; \quad (\text{D-2})$$

$$g = \sum_{t=1}^{N_t} \left\{ \sum_{v=1}^{N_v} \left[ -r_{v,t}^{\text{UP\_FCR}} \cdot A^{\text{UP\_FCR}} \cdot \Delta \cdot CA_t^{\text{UP\_FCR}} + r_{v,t}^{\text{DN\_FCR}} \cdot A^{\text{DN\_FCR}} \cdot \Delta \cdot CA_t^{\text{DN\_FCR}} - r_{v,t}^{\text{UP\_aFRR}} \cdot A^{\text{UP\_aFRR}} \cdot \Delta \cdot CA_t^{\text{UP\_aFRR}} + r_{v,t}^{\text{DN\_aFRR}} \cdot A^{\text{DN\_aFRR}} \cdot \Delta \cdot CA_t^{\text{DN\_aFRR}} \right] \right\}; \quad (\text{D-3})$$

Eq. (D-2) manages the costs not associated with reserve activation, while the costs stemming from the reserve activation are summed in eq. (D-3). Such division of OF is used to ease the writing and understanding of the equations in Section II-C.

$$e_{v,t}^{\text{BUY\_DAM}}, e_{v,t}^{\text{SELL\_DAM}}, r_{v,t}^{\text{UP\_FCR}}, r_{v,t}^{\text{DN\_FCR}}, r_{v,t}^{\text{UP\_aFRR}}, r_{v,t}^{\text{DN\_aFRR}} \geq 0; \quad (\text{D-4})$$

$$e_{v,t}^{\text{SELL\_DAM}}/\Delta - e_{v,t}^{\text{BUY\_DAM}}/\Delta + r_{v,t}^{\text{UP\_FCR}} + r_{v,t}^{\text{UP\_aFRR}} \leq \min(P_v^{\text{OBC\_MAX}}, P_{v,t}^{\text{CP\_MAX}}); \quad (\text{D-5})$$

$$e_{v,t}^{\text{BUY\_DAM}}/\Delta - e_{v,t}^{\text{SELL\_DAM}}/\Delta + r_{v,t}^{\text{DN\_FCR}} + r_{v,t}^{\text{DN\_aFRR}} \leq \min(P_v^{\text{OBC\_MAX}}, P_{v,t}^{\text{CP\_MAX}}); \quad (\text{D-6})$$

The DA variables are modeled as positive values in eq. (D-4). Charging/discharging power is limited with the On-Board Charger (OBC) and Charging Point capacity in eqs. (D-5) and (D-6). The lower value limits the exchanged power with grid.

$$soe_{v,t}^{\text{EV}} = SOE^{\text{TO}} \cdot B_v + h_{v,t} + k_{v,t}; \quad (\text{D-7})$$

$$h_{v,t} = \sum_{\tau=1}^t \left\{ e_{v,\tau}^{\text{BUY\_DAM}} \cdot \eta^{\text{CH}} - e_{v,\tau}^{\text{SELL\_DAM}}/\eta^{\text{DCH}} \right\}$$

$$-E_{v,\tau}^{\text{RUN}}/\eta^{\text{RUN}} + e_{v,\tau}^{\text{FCH}} \cdot \eta^{\text{FCH}} \}; \quad (\text{D-8})$$

$$k_{v,t} = \sum_{\tau=1}^t \left\{ \Delta \cdot [\eta^{\text{CH}} \cdot (r_{v,\tau}^{\text{DN\_FCR}} \cdot A^{\text{DN\_FCR}} + r_{v,\tau}^{\text{DN\_aFRR}} \cdot A^{\text{DN\_aFRR}}) - 1/\eta^{\text{DCH}} \cdot (r_{v,\tau}^{\text{UP\_FCR}} \cdot A^{\text{UP\_FCR}} + r_{v,\tau}^{\text{UP\_aFRR}} \cdot A^{\text{UP\_aFRR}})] \right\}; \quad (\text{D-9})$$

The SOE is calculated as a summation of the initial SOE and all the energy charged/discharged to/from the battery until the time-step  $t$  in eq. (D-7). Similarly as in the OF equation (D-1), the eq. (D-7) has its terms divided into two categories: variable  $h_{v,t}$  defined in eq. (D-8) deals with variables not associated with reserve activation, while the variable  $k_{v,t}$  defined in eq. (D-9) deals with reserve activation variables (later modeled as random parameters). Energy charged/discharged as reserve activation is calculated with inputs  $A^{\{\text{UP/DN}\}-\{\text{FCR/aFRR}\}} \in [0, 1]$ . Note that in det. case these are fixed scalars, however in subsequent Section, they will be changed to random parameters.

$$SOE^{\text{MIN}} \cdot B_v \leq soe_{v,t}^{\text{EV}} + e_{v,t+1}^{\text{BUY\_DAM}} \cdot \eta^{\text{CH}} - e_{v,t+1}^{\text{SELL\_DAM}}/\eta^{\text{DCH}} - \Lambda \cdot \Delta/\eta^{\text{DCH}} \cdot (r_{v,t+1}^{\text{UP\_FCR}} + r_{v,t+1}^{\text{UP\_aFRR}}) - E_{v,t+1}^{\text{RUN}}/\eta^{\text{RUN}} + e_{v,t+1}^{\text{FCH}} \cdot \eta^{\text{FCH}} \quad \forall t \in \mathcal{T}_{(t \neq N_t)}; \quad (\text{D-10})$$

$$SOE^{\text{MAX}} \cdot B_v \geq soe_{v,t}^{\text{EV}} + e_{v,t+1}^{\text{BUY\_DAM}} \cdot \eta^{\text{CH}} - e_{v,t+1}^{\text{SELL\_DAM}}/\eta^{\text{DCH}} + \Lambda \cdot \Delta \cdot \eta^{\text{CH}} \cdot (r_{v,t+1}^{\text{DN\_FCR}} + r_{v,t+1}^{\text{DN\_aFRR}}) - E_{v,t+1}^{\text{RUN}}/\eta^{\text{RUN}} + e_{v,t+1}^{\text{FCH}} \cdot \eta^{\text{FCH}} \quad \forall t \in \mathcal{T}_{(t \neq N_t)}; \quad (\text{D-11})$$

$$SOE^{\text{T0}} \cdot B_v \leq soe_{v,t}^{\text{EV}} \leq SOE^{\text{MAX}} \cdot B_v \quad \text{for } t = N_t; \quad (\text{D-12})$$

$$0 \leq e_{v,t}^{\text{FCH}} \leq P^{\text{FCH\_MAX}} \cdot \Delta; \quad (\text{D-13})$$

Battery capacity is limited with eqs. (D-10) and (D-11) considering the full activation of the reserves. Those two equations ensure that the SOE will be sufficient in the worst case of the reserve activation. The SOE in the final timestep is constrained with Eq. (D-12), while the fast charging limit is set in (D-13). V2G degradation calculus used in this paper is used as in [17]. Eqs (D-4)–(D-13) are valid  $\forall v \in \mathcal{V}$  and  $\forall t \in \mathcal{T}$ , except for eqs. (D-10) – (D-11) which don't apply the final timestep, and (D-12), which applies only in the last step.

### C. Robust Model

Compared to the deterministic model, the activation ratios in robust model are uncertain parameters ( $a_{v,\tau,t}^{\{\text{UP/DN}\}-\{\text{FCR/aFRR}\}}$ ) bounded by the uncertainty set (US) under eqs. (US-1)–(US-15). OF minimizes the total cost (R-1) and maximizes the reserve activation (mimicking the worst-case realization) using eqs. (R-4)–(R-8). Objective function:

$$\min_{\Xi_{\mathcal{O}}} (z) \quad (\text{R-1})$$

subject to:

$$(\text{D-2}), (\text{D-4}) - (\text{D-6}), (\text{D-8}), (\text{D-13}); \quad (\text{R-2})$$

$$(\text{D-3}), (\text{D-9}); \quad (\text{R-3})$$

$$\max_{\Xi_{\mathcal{A}}} (g^{\text{RA}}) \leq z - g^{\text{NRA}}; \quad (\text{R-4})$$

$$\max_{\Xi_{\mathcal{A}}} (-h_{v,t}^{\text{RA}}) \leq B_v \cdot (SOE^{\text{T0}} - SOE^{\text{MIN}}) \quad (\text{R-5})$$

$$-\Lambda \cdot \Delta/\eta^{\text{DCH}} \cdot (r_{v,t+1}^{\text{UP\_FCR}} + r_{v,t+1}^{\text{UP\_aFRR}}) + h_{v,t+1}^{\text{NRA}};$$

$$\max_{\Xi_{\mathcal{A}}} (h_{v,t}^{\text{RA}}) \leq B_v \cdot (SOE^{\text{MAX}} - SOE^{\text{T0}}) \quad (\text{R-6})$$

$$-\Lambda \cdot \Delta \cdot \eta^{\text{CH}} \cdot (r_{v,t+1}^{\text{DN\_FCR}} + r_{v,t+1}^{\text{DN\_aFRR}}) - h_{v,t+1}^{\text{NRA}};$$

$$\max_{\Xi_{\mathcal{A}}} (h_{v,t}^{\text{RA}}) \leq B_v \cdot (SOE^{\text{MAX}} - SOE^{\text{T0}}) - h_{v,t}^{\text{NRA}}; \quad (\text{R-7})$$

$$\max_{\Xi_{\mathcal{A}}} (-h_{v,t}^{\text{RA}}) \leq h_{v,t}^{\text{NRA}}, \quad \text{for } t = N_t; \quad (\text{R-8})$$

To be able to solve the master problem with four related maximization subproblems, the model is reformulated using the methodology presented in [18]. Eqs. (R-2) are taken unaltered from the det. model, while eqs. (R-3) uses an activation variable instead of a fixed activation parameter. Each of the constraints (including OF) with uncertain parameters from (R-3) are modeled as independent maximization subproblems (R-4)–(R-8). OF of the deterministic model eq. (D-1) is recast as a robust subproblem in eqs. (R-1) and (R-4). SOE bounds from Eqs. (D-10)–(D-12) are reformulated in eqs. (R-5)–(R-8).

### D. Uncertainty Set

The US is necessary to bound the uncertain reserve activation parameters which are recast as variables of the inner subproblems (R-5)–(R-8). The US stems from the real data taken from RTE for 2018, where the activation ratio is calculated as *FCR/aFRR Activated Reserve Energy* divided by *(FCR/aFRR Accepted Reserve Capacity) · Δ* in each half-hourly timestep.

After a detailed statistical evaluation for each reserve type (statistics for FCR are shown in Figures 1a–1b, due to succinctness of the paper the aFRR analysis is omitted) two main sets of constraints were constructed: one for single activation in each timestep shown in Figure 1a and one for daily summation of activations shown in Figure 1b. Within each of these sets, three uncertain parameters are observed: up (the top graph on each subfigure), down (the right graph) and up+down activation (the bottom graph). On each of these graphs three areas are defined, the distribution between the borders: min and max (Q0 – yellow), 1% and 99% (Q1 – green) and 5% and 95% (Q5 – red) of the uncertain parameter.

Each of those areas represent a tested scenario for sensitivity analysis (apart those, two more scenarios are tested: Q10 and Q25, but these are omitted from figures as too many borders make figures hard to read and understand). On scatter graph in the center of the subfigures we can see an interrelation between the up and down uncertain parameters where the borders from all three side graphs are displayed (vertical lines – up, horizontal lines – down, slope lines – up + down activation border). The shaded areas in the scatter graph represent the area of a specific budget of uncertainty between all borders (yellow, green, red).

For example, if the Figure 1a is to be observed the upper left graph represents the distribution of the FCR up reserve activation ratios in half-hour resolution. It can be seen that 95% of activations is less than 21% (red curve) of the total available FCR up capacity. On the same graph, it could be seen that the half-hourly activations never cross the 47% (yellow curve) of the total available capacity. In the same manner the leftmost graph displays the down FCR data, and

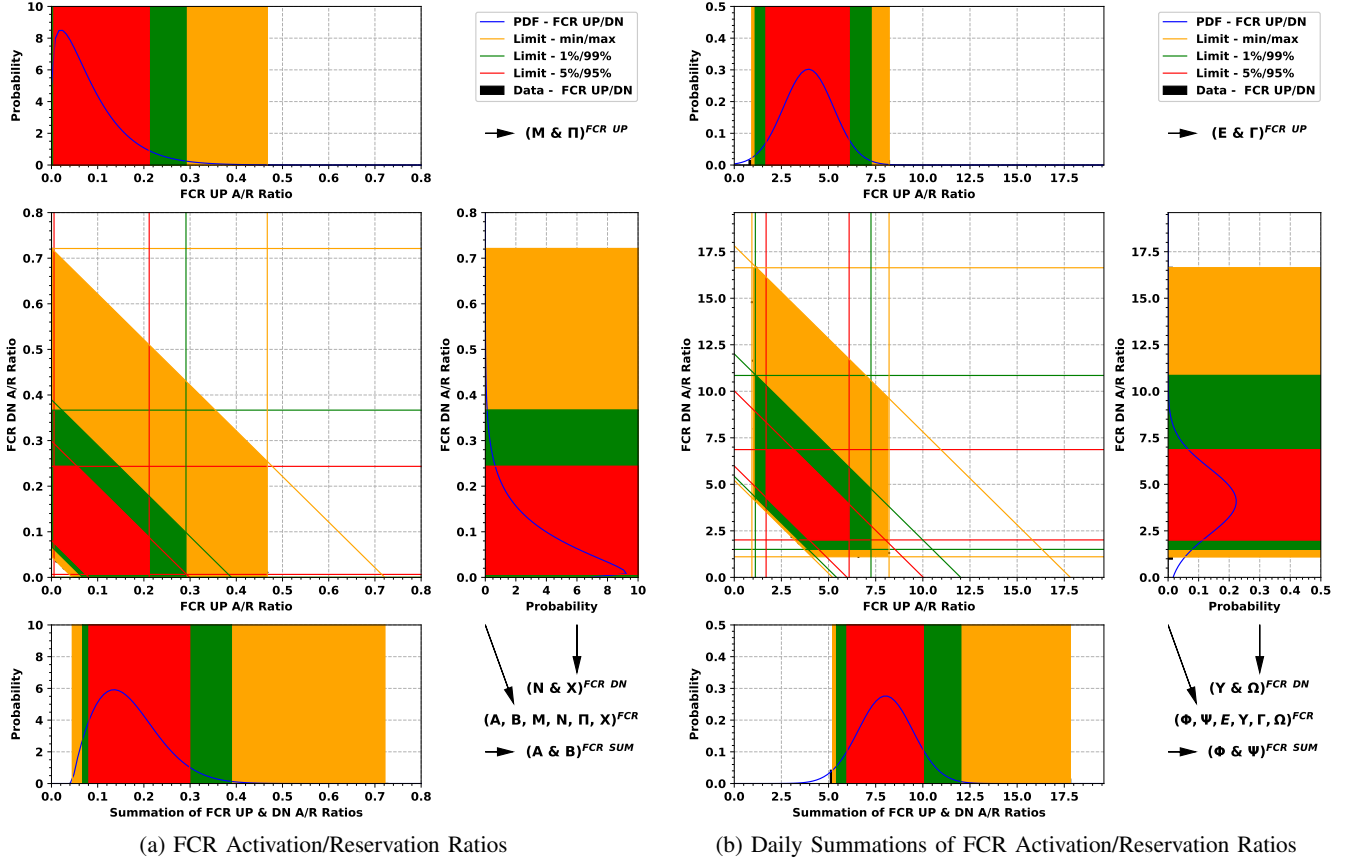

Fig. 1: Statistical Plots of FCR Activation/Reservation Ratios

the lowest graph displays the summation of up and down FCR activation ratios. The middle scatter graph provides the mutual dependence of up and down FCR activations. The yellow slope line, from 0.72 down ratio to 0.72 up ratio, presents the limit for the summation of the up and down ratios (i.e. half hourly summations of ratios never pass the 72% of total capacity), whereas the green slope line from 0.38-0.38 presents the limit which the summation of up and down FCR ratios crossed only 1% of all half-hourly timesteps.

The graphically presented constraints from the Figure 1 are mathematically represented with the following US equations:  
 $\forall (a_{v,\tau,t}^{UP\_FCR}, a_{v,\tau,t}^{DN\_FCR}, a_{v,\tau,t}^{UP\_aFRR}, a_{v,\tau,t}^{DN\_aFRR}) \in \mathcal{A}$ , where  $\mathcal{A}$  is:

$$\mathcal{A} = \{a_{v,\tau,t}^{UP\_FCR}, a_{v,\tau,t}^{DN\_FCR}, a_{v,\tau,t}^{UP\_aFRR}, a_{v,\tau,t}^{DN\_aFRR} \mid a_{v,\tau,t}^{UP\_FCR}, a_{v,\tau,t}^{DN\_FCR}, a_{v,\tau,t}^{UP\_aFRR}, a_{v,\tau,t}^{DN\_aFRR} \geq 0; \quad (US-1)$$

$$a_{v,\tau,t}^{UP\_FCR} + a_{v,\tau,t}^{DN\_FCR} \geq A^{FCR} : \alpha_{v,\tau,t}^{(R-5)\_FCR}; \quad (US-2)$$

$$a_{v,\tau,t}^{UP\_FCR} + a_{v,\tau,t}^{DN\_FCR} \leq B^{FCR} : \beta_{v,\tau,t}^{(R-5)\_FCR}; \quad (US-3)$$

$$a_{v,\tau,t}^{UP\_FCR} \geq \Pi^{FCR} : \pi_{v,\tau,t}^{(R-5)\_FCR}; \quad (US-4)$$

$$a_{v,\tau,t}^{DN\_FCR} \geq X^{FCR} : \chi_{v,\tau,t}^{(R-5)\_FCR}; \quad (US-5)$$

$$a_{v,\tau,t}^{UP\_FCR} \leq M^{FCR} : \mu_{v,\tau,t}^{(R-5)\_FCR}; \quad (US-6)$$

$$a_{v,\tau,t}^{DN\_FCR} \leq N^{FCR} : \nu_{v,\tau,t}^{(R-5)\_FCR}; \quad (US-7)$$

$$\sum_{\tau=1}^t a_{v,\tau,t}^{UP\_FCR} + \sum_{\tau=1}^t a_{v,\tau,t}^{DN\_FCR} \geq \Phi_t^{FCR} : \phi_{v,t}^{(R-5)\_FCR}; \quad (US-8)$$

$$\sum_{\tau=1}^t a_{v,\tau,t}^{UP\_FCR} + \sum_{\tau=1}^t a_{v,\tau,t}^{DN\_FCR} \leq \Psi_t^{FCR} : \psi_{v,t}^{(R-5)\_FCR}; \quad (US-9)$$

$$\sum_{\tau=1}^t a_{v,\tau,t}^{UP\_FCR} \geq E_t^{FCR} : \epsilon_{v,t}^{(R-5)\_FCR}; \quad (US-10)$$

$$\sum_{\tau=1}^t a_{v,\tau,t}^{DN\_FCR} \geq \Upsilon_t^{FCR} : \upsilon_{v,t}^{(R-5)\_FCR}; \quad (US-11)$$

$$\sum_{\tau=1}^t a_{v,\tau,t}^{UP\_FCR} \leq \Gamma_t^{FCR} : \gamma_{v,t}^{(R-5)\_FCR}; \quad (US-12)$$

$$\sum_{\tau=1}^t a_{v,\tau,t}^{DN\_FCR} \leq \Omega_t^{FCR} : \omega_{v,t}^{(R-5)\_FCR}; \quad (US-13)$$

(US-2) - (US-13) are analogous for aFRR; (US-14)

(US-2) - (US-14) are similar for (R-4) - (R-8). (US-15)

The borders are modeled using the US under eqs. (US-1) - (US-13) for the FCR service and for the subproblem stated in (R-5). The (US-14) spreads it over aFRR service and (US-15) over other robust subproblems. For constraints (R-5) and (R-6) the US is applied up to a specific time-step  $t$  and for a specific EV  $v$ . The US equations, uncertain parameters and dual variables for (R-6) are the same as for (R-5). For subproblems (R-4), (R-7) and (R-8) equations are similar in nature but have different indices: US for OF (R-4) is applied over the whole observed horizon  $[1, N_t]$  and over the whole observed fleet  $[1, N_v]$ , whereas for the (R-8) it is applied up to the last time-step  $Nt$  and for specific EV  $v$ .

The connection of the graphical and mathematical US constraints is indicated in Figure 1 on top and bottom right

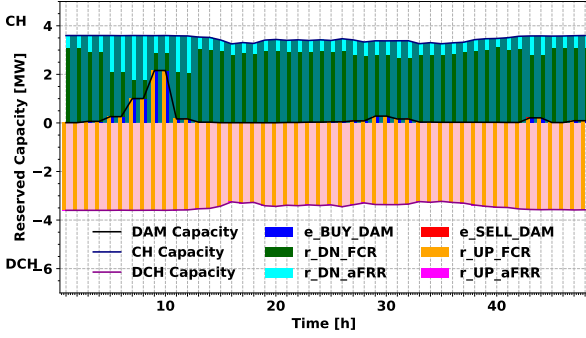

Fig. 2: Deterministic Case Scheduling Results

corners of each subfigure, e.g. on Subfigure 1a limits for eqs. (US-4) and (US-6) are stated in the top right corner. Note that the upper case Greek letters on Figure 1 are the right hand sides of the US equations.

### III. TESTING AND VALIDATION

To validate the goal of the robust model and to enable EV reserve provision without exceeding the SOE limits, the deterministic model with average yearly activation ratios will serve as a reference case. The robust model will be tested with 5 different USs, each representing a quantile of the observed random parameter: 0 (Q0), 1 (Q1), 5 (Q5), 10 (Q10), 25% (Q25). For example, US of 5% for the UP FCR activation ratio means neglecting the 5% of the lowest ( $\Pi^{\text{FCR}}$ ) and highest ( $M^{\text{FCR}}$ ) values of the UP FCR activation (red curves/area in the top graph in Figure 1a).

#### A. Input Parameters

The EV driving/parking behaviour from the JRC European driving study [19] and [20] was used and reformulated as two input parameters used in this paper: EV driving consumption ( $E_{v,t}^{\text{RUN}}$  in eq. (D-7)) and maximum possible CP energy ( $E_{v,t}^{\text{CP\_MAX}}$  in eqs. (D-5) and (D-6)). The EV behaviour for France was simulated with total number of EVs 581. Vehicle type and trip data was used as the basis to create three EV models for this simulations with three distinct parameters: battery capacity, OBC size, and fleet share. Those three types are: small EV (20 kWh, 3.7 kW, 30%), medium EV (40 kWh, 7.4 kW, 40%) and large EV (60 kWh, 11 kW, 30%). In total, the fleet's battery capacity is 23 MWh, whereas the installed OBC power is 4 MW. For the simulation purposes, the price data (energy and reserve) is also used for the French power system. From the French EPEX DA market price (September 21, 2018 – average: 48.86 €/MWh) and from the RTE website the FCR reserve price (first week of 2019 – 4.83 €/MW/0.5h) are taken. Since aFRR during that period was priced at a regulated fee, that fee is used for both directions: 4.84 €/MW/0.5h.

#### B. Results

The scheduling results are shown in Figures 2–3, whereas the ex-post simulation results using 100 real-world scenarios are summarized in Figure 4. Figures 2–3 show the solution of DA bidding variables in MW over whole fleet in each timestep.

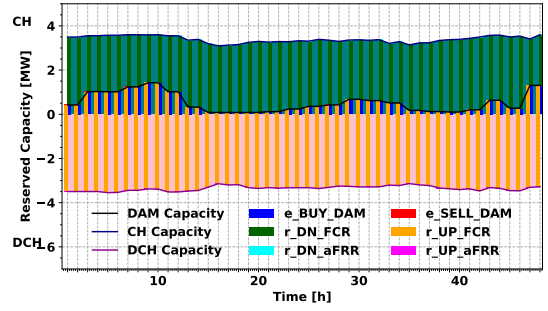

(a) Robust Case – US: Q25

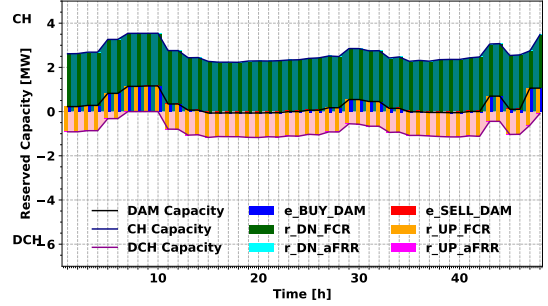

(b) Robust Case – US: Q5

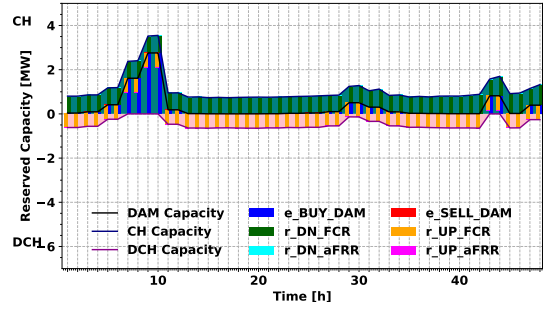

(c) Robust Case – US: Q0

Fig. 3: Robust Cases Scheduling Results

Figure 4 shows four types of model validation parameters: min/max ind. SOE (right axis in %) and min/max fleet-wise energy exceeding the SOE limits (left axis in MWh). All validation parameters refer to the worst-case scenario. Figure 2 shows the DA plans for the reference deterministic case, whereas Figure 3 show the robust model results for the US of 25, 5, and 0% quantiles. The deterministic case bids in the reserve market in a very wide range where average bid reserve capacities are 6.29 and 4.49 fleet-wise for up and down FCR, respectively (Figure 2). The mild activation constraints of 25% quantile do not consider more than 50% of realized historic activations and such bidding is even more intense where average bid capacities are 6.67 and 4.95 MW for up and down FCR, respectively (Figures 3a). Tightening the activation constraints to 5% quantile, to be closer to their min/max values, the amount of bid capacities decreases and in average it makes 1.94 and 4.05 MW for up and down FCR, respectively (Figure 3b). The smallest amounts of bid capacities are achieved for the tightest constraints set on their min/max values (Figure 3c). In average, for Q0, bid



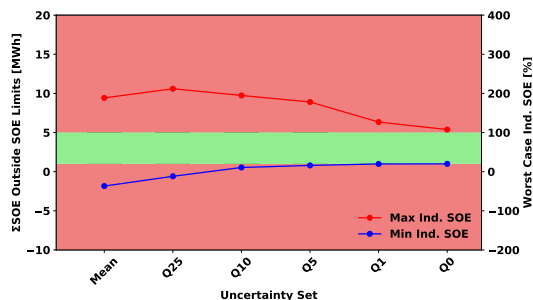

Fig. 4: Comparison of Validation Parameters for Tested Cases

up and down FCR capacities are 1.11 and 1.34, respectively. Note that only deterministic case utilized smaller amounts of aFRR reserve, whereas robust model completely neglected that option. The main reason for such happening is that aFRR is highly more uncertain than FCR.

In correlation to the amount of bid capacities for robust cases, the validation parameters also decrease as the constraints tighten, as shown on Figure 4. It is clear that US of Q25 doesn't sufficiently bound the reserve activation, and that it results in worse solution than deterministic case. The total energy beyond the SOE limits (green + yellow from Figure 4) in Q25 is 18.57 MWh and in deterministic case it is 16.38 MWh. Maximal individual SOE is worse in Q25 than in deterministic case, but the min SOE is better in Q25. Other robust cases have no problems with min SOE constraint at all. Q10 and Q5 have both less fleet-wise energy beyond SOE limits (in total) and slightly better max SOE than det. case but still their results yield too much SOE violations. Q1, however, shows the true face of robust solution where the SOE limits are only slightly violated in over  $SOE^{MAX}$  direction with energy exceeding  $SOE^{MAX}$  in amount of around 3 MWh with maximal SOE of 126.86%. The Q0 case provides the most conservative solution without any SOE violation whatsoever. In sense of SOE violation this is the best solution, but being conservative in SOE limits aspect directly means lower revenues in financial aspect.

#### IV. DISCUSSION AND CONCLUSION

This paper proposed a detail robust EV scheduling model which encompasses uncertainty of reserve activation. To create uncertainty sets and validation scenarios real balancing data from European TSOs was used. The statistical analysis of the activation/reservation defined the uncertainty sets. Then the sensitivity analysis on different uncertainty sets (0-25%) was performed and all of them were compared to det. case often used in the literature. The main finding of the paper is the proof that uncertainty of reserve activation can be adequately cast in a robust form and that such models can guarantee EV reserve scheduling without possibility of crossing the SOE limits. Neglecting more than 1% of historic activation can result in too liberal model which doesn't fulfill its task of securing the battery limits. However, models with less than 1% of historic activation are pretty conservative and yield lower profits. The compromise between the covered uncertainty and

expected profit must be made while considering the tightness of the robust formulation. The beauty of the proposed model lies in the possibility to use the formulation for other technologies (stationary batteries, power plants...), jointly with other markets and along with other uncertainties such as price, EV behaviour, bidding acceptance etc.

#### REFERENCES

- [1] International Energy Agency, "Global EV Outlook 2019," 2019.
- [2] IRENA (2019), Innovation landscape brief: Electric-vehicle smart charging, International Renewable Energy Agency, Abu Dhabi.
- [3] I. Pavić, T. Capuder, and I. Kuzle, "Low carbon technologies as providers of operational flexibility in future power systems," *Appl. Energy*, vol. 168, pp. 724–738, Apr. 2016.
- [4] ENTSO-E, "ENTSO-E Balancing Report," 2020.
- [5] Ramboll, "Ancillary Services From New Technologies," 2019.
- [6] J. Engels, "Integration of Flexibility from Battery Storage in the Electricity Market," 2020.
- [7] M. Alipour, B. Mohammadi-Ivatloo, M. Moradi-Dalvand, and K. Zare, "Stochastic scheduling of aggregators of plug-in electric vehicles for participation in energy and ancillary service markets," *Energy*, vol. 118, pp. 1168–1179, Jan. 2017.
- [8] M. Shafie-Khah, M. P. Moghaddam, M. K. Sheikh-El-Eslami, and J. P. S. Catalão, "Optimised performance of a plug-in electric vehicle aggregator in energy and reserve markets," *Energy Convers. Manag.*, vol. 97, pp. 393–408, Jun. 2015.
- [9] I. Momber, A. Siddiqui, T. G. S. Roman, and L. Soder, "Risk averse scheduling by a PEV aggregator under uncertainty," *IEEE Trans. Power Syst.*, vol. 30, no. 2, pp. 882–891, Mar. 2015.
- [10] S. I. Vagropoulos and A. G. Bakirtzis, "Optimal bidding strategy for electric vehicle aggregators in electricity markets," *IEEE Trans. Power Syst.*, vol. 28, no. 4, pp. 4031–4041, 2013.
- [11] P. Sanchez-Martin, S. Lumberras, and A. Alberdi-Alen, "Stochastic programming applied to ev charging points for energy and reserve service markets," *IEEE Trans. Power Syst.*, vol. 31, no. 1, Jan. 2016.
- [12] C. Goebel and H. A. Jacobsen, "Aggregator-Controlled EV Charging in Pay-as-Bid Reserve Markets with Strict Delivery Constraints," *IEEE Trans. Power Syst.*, vol. 31, no. 6, pp. 4447–4461, Nov. 2016.
- [13] M. Kazemi, H. Zareipour, N. Amjadi, W. D. Rosehart, and M. Ehsan, "Operation Scheduling of Battery Storage Systems in Joint Energy and Ancillary Services Markets," *ITSG*, vol. 8, no. 4, Oct. 2017.
- [14] M. R. Sarker, Y. Dvorkin, and M. A. Ortega-Vazquez, "Optimal participation of an electric vehicle aggregator in day-ahead energy and reserve markets," *IEEE Trans. Power Syst.*, vol. 31, no. 5, Sep. 2016.
- [15] B. Han, S. Lu, F. Xue, and L. Jiang, "Day-ahead electric vehicle aggregator bidding strategy using stochastic programming in an uncertain reserve market," *IET Gener. Transm. Distrib.*, vol. 13, no. 12, Jun. 2019.
- [16] I. Pavić, H. Pandžić, T. Capuder, "Electric Vehicles as Frequency Containment Reserve Providers," *IEEE International Energy Conference (ENERGYCON)*, Gammarth, Tunisia, 2020.
- [17] I. Pavić, H. Pandžić, and T. Capuder, "Electric vehicle based smart e-mobility system – Definition and comparison to the existing concept," *Appl. Energy*, vol. 272, p. 115153, Aug. 2020.
- [18] J. M. Morales, A. J. Conejo, H. Madsen, P. Pinson, and M. Zugno, *Integrating Renewables in Electricity Markets*, vol. 205. Boston, MA: Springer US, 2014.
- [19] G. Pasaoglu, D. Fiorello, A. Martino, G. Scarcella, A. Alemanno, A. Zubaryeva, C. Thiel, and L. P. O. of the E. Union, "Driving and parking patterns of European car drivers - a mobility survey" 2012.
- [20] G. Pasaoglu, D. Fiorello, L. Zani, A. Martino, A. Zubaryeva, and C. Thiel, "Projections for Electric Vehicle Load Profiles in Europe Based on Travel Survey Data Contact information", vol. 1. 2013.



# Biography

Ivan Pavić is a senior researcher at Department of Energy and Power Systems at Faculty of Electrical Engineering and Computing, University of Zagreb. He received his bachelor's and master's degree in July 2012 and 2014 of the same Faculty, respectively.

His research interests are integration of novel distributed technologies, especially electric vehicles, into the power system and electricity markets as well as overall system planning and optimization. In his research activities special attention is on the development of market bidding algorithms for various stakeholders and the design of market clearing algorithms.

He participated in numerous science projects funded by European Commission and Croatian Science Foundation. Most of them are related to electric vehicles, prosumers, and microgrids and their market participation. Alongside active participation on the projects daily routines, he also took part into writing of the proposals for some of the projects.

Ivan is involved into teaching activities as teaching assistant in Master Programme courses (Electric Power Market, Electric Power System Maintenance, Energy Storage, Power System Planning etc.) and through leading of the laboratory exercises at Smart Grid Laboratory. He spent nine months (2015/2016) on a specialization at Beijing Jiaotong University, Beijing. He has published a range of conference (25) and scientific journal papers (10) and worked on numerous technical studies for national electrical power utility or private investors (long-term development of distribution networks, optimal connection of new grid users to distribution/transmission network, market development, cost-benefit analysis, integration of battery storage).

Ivan is a member of professional associations IEEE, CIGRE, INFORMS, and HDO.

**Journal Papers**

- [J1] I. Pavić, T. Capuder, and I. Kuzle, “Value of flexible electric vehicles in providing spinning reserve services,” *Applied Energy*, vol. 157, pp. 60–74, Nov. 2015, ISSN: 03062619. DOI: 10.1016/j.apenergy.2015.07.070.
- [J2] I. Pavić, T. Capuder, and I. Kuzle, “Low carbon technologies as providers of operational flexibility in future power systems,” *Applied Energy*, vol. 168, pp. 724–738, Apr. 2016, ISSN: 0306-2619. DOI: 10.1016/J.APENERGY.2016.01.123.
- [J3] I. Pavić, T. Capuder, and I. Kuzle, “A Comprehensive Approach for Maximizing Flexibility Benefits of Electric Vehicles,” *IEEE Systems Journal*, pp. 1–12, 2017, ISSN: 1932-8184. DOI: 10.1109/JSYST.2017.2730234.
- [J4] I. Pavić, H. Pandžić, and T. Capuder, “Electric vehicle based smart e-mobility system – Definition and comparison to the existing concept,” *Applied Energy*, vol. 272, pp. 115–153, Aug. 2020, ISSN: 03062619. DOI: 10.1016/j.apenergy.2020.115153.
- [J5] “Generation scheduling in power systems with high penetration of renewable energy,” *Journal of Energy : Energija*, vol. 66, no. 1-4, pp. 150–164, 2017, ISSN: 1849-0751.
- [J6] “Electricity market design in croatia within the european electricity market — recommendations for further development,” *Energies*, vol. 11, no. 2, pp. 1–20, 2018, ISSN: 1996-1073. DOI: 10.3390/en11020346.
- [J7] “Energy and reserve co-optimisation – reserve availability, lost opportunity and uplift compensation cost,” *Iet generation transmission and distribution*, vol. 13, no. 2, pp. 229–237, 2019, ISSN: 1751-8687. DOI: 10.1049/iet-gtd.2018.5480.
- [J8] “Defining and evaluating use cases for battery energy storage investments: Case study in croatia,” *Energies*, vol. 12, no. 3, p. 376, 2019, ISSN: 1996-1073. DOI: 10.3390/en12030376.
- [J9] “Experimental testing and evaluation of lithium-ion battery cells for a special-purpose electric vacuum sweeper vehicle,” *IEEE access*, vol. 8, pp. 216 308–216 319, 2020, ISSN: 2169-3536. DOI: 10.1109/access.2020.3040206.
- [J10] “Optimal battery storage participation in european energy and reserves markets,” *Energies*, vol. 13, pp. 1–22, 2020, ISSN: 1996-1073. DOI: 10.3390/en13246629.

## Conference Papers

- [C1] I. Pavić, T. Capuder, N. Holjevac, and I. Kuzle, “Role and impact of coordinated EV charging on flexibility in low carbon power systems,” in *2014 IEEE International Electric Vehicle Conference (IEVC)*, IEEE, Dec. 2014, pp. 1–8, ISBN: 978-1-4799-6075-0. DOI: 10.1109/IEVC.2014.7056172.
- [C2] I. Pavić, T. Capuder, and I. Kuzle, “Defining the Role of Traditional and Low Carbon Technologies in Providing Flexibility for Future Power Systems Operation,” in *Digital Proceedings of the 10th Conference on Sustainable Development of Energy, Water and Environment Systems – SDEWES*, 2015.
- [C3] T. Martinsen, N. Holjevac, B. A. Bremdal, I. Kuzle, J. M. Guerrero, T. Dragičević, I. Pavić, and Q. Shafiee, “Improved Grid Operation Through Power Smoothing Control Strategies Utilizing Dedicated Energy Storage at an Electric Vehicle Charging Station,” in *CIREN Workshop Helsinki*, 2016, pp. 1–4.
- [C4] I. Pavić, N. Holjevac, M. Zidar, I. Kuzle, and A. Nešković, “Transportation and power system interdependency for urban fast charging and battery swapping stations in Croatia,” in *2017 40th International Convention on Information and Communication Technology, Electronics and Microelectronics, MIPRO 2017 - Proceedings*, 2017, ISBN: 9789532330922. DOI: 10.23919/MIPRO.2017.7973652.
- [C5] I. Pavić, T. Capuder, N. Holjevac, and I. Kuzle, “Utjecaj električnih vozila na razvoj prijenosnog sustava,” in *2017 40th International Convention on Information and Communication Technology, Electronics and Microelectronics, MIPRO 2017 - Proceedings*, Opatija, 2017.
- [C6] I. Pavić, T. Capuder, and I. Kuzle, “Fast charging stations — Power and ancillary services provision,” in *2017 IEEE Manchester PowerTech*, IEEE, Jun. 2017, pp. 1–6, ISBN: 978-1-5090-4237-1. DOI: 10.1109/PTC.2017.7981190.
- [C7] I. Pavić, T. Capuder, I. Kuzle, and H. Pandžić, “Analiza aspekata fleksibilnosti budućeg elektroenergetskog sustava s integriranim električnim vozilima,” in *13. savjetovanje HRO CIGRÉ*, 2017, pp. 1–10.
- [C8] M. Zidar, I. Pavić, N. Holjevac, D. Jakšić, T. Radočaj, and I. Kuzle, “Integracija infrastrukture za punjenje električnih vozila u distribucijsku mrežu Karlovca,” in *13. savjetovanje HRO CIGRÉ*, 2017, pp. 1–8.
- [C9] I. Pavić, T. Capuder, and H. Pandžić, “Profit margin of electric vehicle battery aggregator,” in *2018 IEEE International Energy Conference (ENERGYCON)*, IEEE, Jun. 2018, pp. 1–6, ISBN: 978-1-5386-3669-5. DOI: 10.1109/ENERGYCON.2018.8398790.

- [C10] I. Pavić, H. Pandžić, and T. Capuder, “Electric vehicles as frequency containment reserve providers,” in *6th IEEE International Energy Conference, ENERGYCon 2020*, Institute of Electrical and Electronics Engineers Inc., Sep. 2020, pp. 911–917, ISBN: 9781728129563. DOI: 10.1109/ENERGYCon48941.2020.9236585.
- [C11] I. Pavić, H. Pandžić, and T. Capuder, “Tight Robust Formulation for Uncertain Reserve Activation of an Electric Vehicle Aggregator,” in *2021 IEEE PowerTech*, Madrid, 2021, pp. 1–6.
- [C12] “Distribution network reliability and asset management,” in *Proceedings of International Conference on Condition Monitoring, Diagnosis and Maintenance 2015*, 2015, pp. 205–214.
- [C13] “Operational reliability impact on development and maintenance of the distribution system,” in *5. savjetovanje Hrvatskog ogranka Međunarodne elektrodistribucijske konferencije*, 2016, pp. 1–7.
- [C14] “Operating reserve allocation methods relative to energy unit commitment,” in *International Conference on Energy, Power and Environmental Engineering (ICEPEE 2017)*, P. International Conference on Energy, Ed., DEStech Publications, Inc., 2017, pp. 243–249, ISBN: 978-1-60595-456-1.
- [C15] “Electricity markets overview — market participation possibilities for renewable and distributed energy resources,” in *14th International Conference on the European Energy Market (EEM)*, Curran Associates, 2017, pp. 1–5, ISBN: 978-1-5090-5499-2. DOI: 10.1109/EEM.2017.7981917.
- [C16] “Capacity remuneration mechanisms in energy winter package,” in *13. savjetovanje HRO CIGRÉ*, 2017, pp. 1–7.
- [C17] “Croatian electricity market – position of distributed energy resources,” in *13. savjetovanje HRO CIGRÉ*, 2017, pp. 1–10.
- [C18] “Models for the participation of aggregators of distributed flexibility services providers in the electricity market in croatia,” in *Sixth Session of CIRED Croatian National Committee*, 2018, pp. 1–10.
- [C19] “Decentralized master-slave communication and control architecture of a battery swapping station,” in *18th IEEE International Conference on Environment and Electrical Engineering*, 2018, pp. 1–6.
- [C20] “Impact of an aggregator of distributed energy resources on traditional power system participants,” in *Cired Workshop 2018 on Microgrids and Local Energy Communities*, 2018, pp. 1–4.

- [C21] “A review of energy storage systems applications,” in *Mediterranean Conference on Power Generation, Transmission, Distribution and Energy Conversion*, 2018, pp. 1–6.
- [C22] “Effect of stochastic variables on balancing mechanism,” in *2019 International Conference on Modeling, Simulation, Optimization and Numerical Techniques (SMONT)*, Atlantis press, 2019, pp. 211–214, ISBN: 978-94-6252-712-6. DOI: 10.2991/smont-19.2019.47.
- [C23] “Market-oriented power system operation adjusted for new distributed technology – case study france,” in *14. savjetovanje HRO CIGRE*, 2019, pp. 1–9.
- [C24] “Dynamic electricity pricing tariffs:trade-offs for suppliers and consumers,” in *Mediterranean Conference on Power Generation, Transmission, Distribution and Energy Conversion 2020.*, 2020, ch. 1, p. 6.
- [C25] M. Kostelac, I. Pavić, and T. Capuder, “Mathematical model of flexible multi-energy industrial prosumer under uncertainty,” in *2020 International Conference on Smart Energy Systems and Technologies (SEST)*, 2020, pp. 1–6. DOI: 10.1109/SEST48500.2020.9203240.
- [C26] M. Kostelac, I. Pavić, and T. Capuder, “Mathematical model of flexible multi-energy industrial prosumer under uncertainty,” in *2020 International Conference on Smart Energy Systems and Technologies (SEST)*, 2020, pp. 1–6. DOI: 10.1109/SEST48500.2020.9203240.

# Životopis

Ivan Pavić trenutno je zaposlen kao iskusni istraživač na Zavodu za visoki napon i energetiku Fakulteta elektrotehnike i računarstva Sveučilišta u Zagrebu. Prvostupnikom na istom fakultetu je postao 2012. godine, a diplomirao je 2014. godine.

Njegovo područje interesa je integracija novih distribuiranih tehnologija, posebno električnih vozila, u elektroenergetski sustav i na tržišta električne energije te planiranje i optimizacija sustava kao cjeline. U njegovim istraživačkim aktivnostima posebna je pažnja posvećena razvoju algoritama za sudjelovanje na tržištima za različite dionike te dizajn algoritama za čišćenje tržišta.

Sudjelovao je u različitim znanstvenim projektima financiranim od Europske komisije i Hrvatske zaklade za znanost. Većina spomenutih projekata bavi se električnim vozilima, prosumerima, mikromrežama te njihovim sudjelovanjem na tržištima. Uz aktivno djelovanje na svakodnevnim poslovima na projektima, također je sudjelovao u pisanju prijava za neke od njih.

Uključen je u nastavne aktivnosti na diplomskom studiju kao asistent (Tržište električne energije, Održavanje elektroenergetskog sustava, Spremnici energije, Planiranje pogona sustava itd.) te kao voditelj laboratorijskih vježbi unutar Laboratorija za napredne elektroenergetske mreže. Proveo je 9 mjeseci (2015./2016.) na usavršavanju na Beijing Jiaotong University, Peking, Kina.

Objavio je veći broj znanstvenih radova na konferencijama (25) i u časopisima (10) te je radio na većem broju tehničkih studija za nacionalnu elektroprivredu ili za privatne ulagače (dugoročni razvoj distribucijskih mreža, optimalno tehničko rješenje priključenja za nove korisnike prijenosne ili distribucijske mreže, razvoj tržišta, analiza prednosti i troškova, integracija baterijskih spremnika).

Ivan je član profesionalnih udruženja IEEE, CIGRE, INFORMS, i HDO.